

# Reconstructing the Zhuang zi : preliminary considerations

Autor(en): **Bumbacher, Stephan Peter**

Objektyp: **Article**

Zeitschrift: **Asiatische Studien : Zeitschrift der Schweizerischen  
Asiengesellschaft = Études asiatiques : revue de la Société  
Suisse-Asie**

Band (Jahr): **70 (2016)**

Heft 3

PDF erstellt am: **25.07.2024**

Persistenter Link: <https://doi.org/10.5169/seals-696846>

## **Nutzungsbedingungen**

Die ETH-Bibliothek ist Anbieterin der digitalisierten Zeitschriften. Sie besitzt keine Urheberrechte an den Inhalten der Zeitschriften. Die Rechte liegen in der Regel bei den Herausgebern. Die auf der Plattform e-periodica veröffentlichten Dokumente stehen für nicht-kommerzielle Zwecke in Lehre und Forschung sowie für die private Nutzung frei zur Verfügung. Einzelne Dateien oder Ausdrucke aus diesem Angebot können zusammen mit diesen Nutzungsbedingungen und den korrekten Herkunftsbezeichnungen weitergegeben werden. Das Veröffentlichen von Bildern in Print- und Online-Publikationen ist nur mit vorheriger Genehmigung der Rechteinhaber erlaubt. Die systematische Speicherung von Teilen des elektronischen Angebots auf anderen Servern bedarf ebenfalls des schriftlichen Einverständnisses der Rechteinhaber.

## **Haftungsausschluss**

Alle Angaben erfolgen ohne Gewähr für Vollständigkeit oder Richtigkeit. Es wird keine Haftung übernommen für Schäden durch die Verwendung von Informationen aus diesem Online-Angebot oder durch das Fehlen von Informationen. Dies gilt auch für Inhalte Dritter, die über dieses Angebot zugänglich sind.

Stephan Peter Bumbacher\*

# Reconstructing the *Zhuang zi*: Preliminary Considerations

DOI 10.1515/asia-2016-0045

**Abstract:** The received version of the text *Zhuang zi* can be traced to the fourth century AD when its commentator Guo Xiang has shortened by roughly a third and rearranged the text available to him. The version(s) current at that time were in all likelihood descendants of the text which Liu Xiang in the first century BC had prepared for the imperial library. The scant hints at his activity are discussed. As Liu Xiang also compiled own works that contain implicit *Zhuang zi* quotations, this allows to partially reconstruct the pre-Guo Xiang text. Some scholars assume that members of the court of Huai nan have produced a redaction of their own in the second half of the second century BC. While this cannot be excluded, evidence is presented that the transmission of the *Zhuang zi* text has not been influenced by the Huai nan scholars. The earliest explicit quotation of the text can be found in the *Lü shi chun qiu* of 239 BC. This source also contains a series of implicit quotations allowing to partially reconstruct the pre-Han *Zhuang zi*. Excavated bamboo slips lead to the identification of later insertions into the text. As the pre-Guo Xiang version survived into the Tang dynasty, a systematic search in a broad range of pre-Tang and Tang texts revealed lost pericopes as well as lost parts of pericopes and lost sentences.

**Keywords:** *Zhuang zi*, textual criticism, variant texts, parallel texts, explicit quotation, implicit quotation

## 1 Introduction

The *Zhuang zi* 莊子, arguably one of the most interesting philosophical works traditional China has produced prior to the Chan texts, is at the same time one of the most problematic as its received version is in a deplorable condition. The original text has been subject to major redactional activities at least twice during its transmission. In the second of these transformation processes its size was reduced by perhaps one third and there are indications of a partial rearranging of the remaining contents. But even the *textus receptus* itself suffered from

---

\*Corresponding author: Stephan Peter Bumbacher, Universities of Basel, Tübingen and Zurich; University of Zurich, Institute of Asian and Oriental Studies, Rämistrasse 59, 8001 Zürich, Switzerland. E-mail: stephan-peter.bumbacher@unibas.ch

occasional losses, changes and insertions since its compilation in the fourth century AD.

Before questions such as “was the original *Zhuang zi* created by one single hand or does it consist of different layers, each of which probably attributable to a defined philosophical milieu and a specific time period” can be seriously raised, it is utterly necessary to search for and collect as many of the lost passages as possible and, taking into account all identified quotations, to establish a critical edition which rightly deserves this title.

The *Zhuang zi* is traditionally attributed to a certain Zhuang Zhou 莊周 who would have lived around 320 BC. The only early source which, apart from the *Zhuang zi* itself, provides us with, however scanty, biographical information about its alleged author is Sima Qian’s 司馬遷 (145–ca. 86 BC) *Shi ji* 史記 of ca. 100 BC.<sup>1</sup> It mentions Zhuang Zhou’s native place Meng 蒙 and a low administrative position he has held. We are also told that he was a contemporary of Kings Hui of Liang 梁惠王 (r. 370–319) and Xuan of Qi 齊宣王 (r. 319–301) (周與梁惠王、齊宣王同時). Unfortunately, Sima Qian does not reveal his sources. As the *Shi ji* episode reporting that King Wei of Chu 楚威王 (r. 339–329 BC) invited Master Zhuang to become prime minister partially corresponds *verbatim* with a pericope of the received *Zhuang zi*,<sup>2</sup> we may suspect that Sima Qian probably did not have independent sources at his disposal but relied on pericopes of the *Zhuang zi* text itself as it was available to him.

He may even have inferred Zhuang Zhou’s *floruit* (“contemporary of Kings Hui of Liang and Xuan of Qi”) from the *Zhuang zi* text itself, as Master Zhuang is repeatedly presented as a friend of Master Hui whom the text has as a sometime prime minister of Liang (惠子相梁)<sup>3</sup> and, according to Sima Biao’s 司馬彪 (240–306) comment, served King Hui of Liang: 惠子謂莊子曰。魏王貽我大瓠之種。(惠子) 司馬(彪)云：姓惠，名施，為梁相。(魏王) 司馬云：梁惠王也。<sup>4</sup> Chapter thirty of the received *Zhuang zi* relates how Master Zhuang, invited by the crown prince, could rid King Wen of Zhao (趙文王) of his passion of being fond of swords.<sup>5</sup> One quotation of this pericope has the king as Huiwen of Zhao (趙惠文王) who would have reigned 298–266 BC.<sup>6</sup>

1 *Shi ji* 63: 2145.

2 *Zhuang zi* 32.46; numbers in the form xx.yy mean “chapter xx”, line yy, according to the Harvard Yenching Concordance.

3 *Zhuang zi* 17.84.

4 *Zhuang zi* 1.42. Sima Biao’s comment is to be found in *Jing dian shi wen* “*Zhuang zi yin yi*” 1: 4bf.

5 *Zhuang zi* 30.1.

6 *Tai ping yu lan* 686: 4b.

To the blatant anachronism of Zhuang Zhou's interview with Duke Ai of Lu (r. 494–469)<sup>7</sup> already Sima Biao's commentary had drawn attention.<sup>8</sup> Another example of anachronism regarding Zhuang Zhou can be seen in chapter twenty-six of the received text, in the second pericope, in which he whose family was said to be poor went to borrow some grain from the Marquis of Jianhe 監河侯.<sup>9</sup> If the marquis, according to Lu Deming's (陸德明, 556–627) *Jing dian shi wen* 經典釋文 (c. 625), who refers to the *Shuo yuan* 說苑 (presented to the throne in 17 BC), is to be identified with the Marquis Wen of Wei 魏文侯,<sup>10</sup> then the said Marquis would have reigned 424–387 BC.<sup>11</sup>

Thus there are three different times when Zhuang Zhou is said to have been active, the latter half of the fifth century BC, the first quarter of the fifth century BC and the last quarter of the fourth century BC. This could be interpreted as seeming to imply that Zhuang Zhou, as a historical person, most likely never existed, but rather was invented by the authors of the *Zhuang zi*. If so, then his purported appearance in different times may even have been deliberately constructed for some reason.

## 1.1 Preliminary definitions

For the sake of the following argument, it may be useful to start with the definitions of some key terms such as “variant texts”, “parallel texts”, “explicit quotation”, and “implicit quotation”.

### 1.1.1 Variant texts

Variant texts can be defined as texts that are identical, yet allowing for variations of characters, occasional omissions, insertions and transpositions of phrases. They are descendants of the same archetype, although intermediate versions may have existed.

It is highly improbable that two authors when narrating the same story will use exactly the same phrasing. Rather, each of them will say it “in his own

<sup>7</sup> *Zhuang zi* 21.38.

<sup>8</sup> *Jing dian shi wen* 21: 31b: 司馬云：莊子與魏惠王、齊威王同時，在哀公後百二十年。

<sup>9</sup> *Zhuang zi* 26.6.

<sup>10</sup> *Jing dian shi wen* 26: 14a, in fact, the received *Shuo yuan* 11: 18a has 莊周貧者，往貸粟於魏文侯曰。

<sup>11</sup> These are the figures given in Chavannes 1969: 296

words”. If, in turn, we do find versions that for their most part correspond *verbatim*, it is highly probably that they – in the last instance – go back to one and the same version, the archetype. (The same holds true for smaller units than whole texts. If non-trivial phrases are identical they must derive from the same text.)

For example, we find in the *Han shi wai zhuan* 韓詩外傳 (of c. 150 BC), attributed to Han Ying 韓嬰 (c. 200–120 BC), the following paragraph<sup>12</sup>:

傳曰：在天者、莫明乎日月，在地者、莫明於水火，在人者、莫明乎禮儀。故日月不高，則所照不遠；水火不積，則光炎不博；禮義不加乎國家，則功名不白。故人之命在天，國之命在禮。君人者、降禮尊賢而王，重法愛民而霸，好利多詐而危，權謀傾覆而亡。詩曰：「人而無禮，胡不遄死！」

A tradition says: “In the sky nothing is brighter than sun and moon. On the earth nothing is brighter than water and fire. In man nothing is brighter than ritual and deportment. Accordingly, when sun and moon are not high, what they illuminate is not distant. When water and fire are not accumulated, their light and flames are not extensive. When ritual and morality are not increased in a state, [its] merit and fame are not clear. Accordingly, the fate of man lies with heaven, the fate of the state lies with ritual. If someone who rules over men submits to the ritual and honours sages he will be a [true] king. If he gives weight to the laws and loves the people he will be a hegemon. If he is fond of profit and multiplies [his] deceptions he will be endangered. [And] if he engages in intrigues and overthrows [other states] he will perish. The Ode says: [...]”

A variant version occurs in Xun Qing’s 荀清 (?335 – ?238 BC) *Xun zi* 荀子<sup>13</sup>:

在天者，莫明於日月，在地者，莫明於水火，在物者，莫明於珠玉，在人者，莫明於禮義。故日月不高，則光明不赫；水火不積，則暉潤不博；珠玉不睹乎外，則王公不以為寶；禮義不加於國家，則功名不白。故人之命在天，國之命在禮。君人者，隆禮尊賢而王，重法愛民而霸，好利多詐而危，權謀傾覆幽險而亡矣。

In the sky nothing is brighter than sun and moon. On the earth nothing is brighter than water and fire. Among things nothing is brighter than pearls and jade. In man nothing is brighter than ritual and righteousness. Accordingly, when sun and moon are not high, their light and brightness are not luminous. When water and fire are not accumulated, their glow and moisture are not extensive. When pearls and jade are not gazed at on the outside kings and dukes will not consider [them] precious. When ritual and morality are not increased in a state, [its] merit and fame are not clear. Accordingly, the fate of man lies with heaven, the fate of the state lies with ritual. If someone who rules over men exalts the ritual and honours sages he will be a [true] king. If he gives weight to the laws and loves the people he will be a hegemon. If he is fond of profit and multiplies [his] deceptions he will be endangered. [And] if he engages in intrigues, overthrows and secretly endangers [other states] he will indeed perish.

<sup>12</sup> *Han shi wai zhuan* 1.5 (numbers in the form x.y are chapter.pericope), Hightower 1952: 15–16.

<sup>13</sup> *Xun zi ji jie* 17: 211, Knoblock III, 1994: 20.

The last part is also to be found elsewhere in *Xunzi*<sup>14</sup>:

人君者，隆禮尊賢而王，重法愛民而霸，好利多詐而危，權謀傾覆幽險而亡。

As for a ruler of men, if he exalts the ritual and honours sages he will be a [true] king. If he gives weight to the laws and loves the people he will be a hegemon. If he is fond of profit and multiplies [his] deceptions he will be endangered. [And] if he engages in intrigues, overthrows and secretly endangers [other states] he will perish.

A synopsis of both versions makes evident that they are almost identical:

Synopsis 1: *Xun zi 17*, *Xun zi 16*, *Han shi wai zhuan 1*

XZ 17	在天者，莫明於日月，在地者，莫明於水火，在物者，莫明於珠玉，	在人者，莫明
HSWZ	傳曰：在天者、莫明乎日月，在地者、莫明於水火，	在人者、莫明

XZ 17	於禮義。故日月不高，則光明不赫；水火不積，則暉潤不博；珠玉不睹乎外，則王公不以為
HSWZ	乎禮儀。故日月不高，則所照不遠；水火不積，則光炎不博：

XZ 17	實；	禮義不加於國家，則功名不白。故人之命在天，國之命在禮。	君人者，隆禮尊賢而
XZ 16			人君者，隆禮尊賢而
HSWZ		禮義不加乎國家，則功名不白。故人之命在天，國之命在禮。	君人者、降禮尊賢而

XZ 17	王，重法愛民而霸，好利多詐而危，權謀傾覆幽險	而亡矣。
XZ 16	王，重法愛民而霸，好利多詐而危，權謀傾覆幽險	而亡。
HSWZ	王，重法愛民而霸，好利多詐而危，權謀傾覆	而亡。

Besides the sentences 在物者，莫明於珠玉 and 珠玉不睹乎外，則王公不以為實 which only occur in the *Xun zi* and the phrase 幽險 which is lacking in the *Han shi wai zhuan*, the variant phrase 所照不遠 versus 光明不赫, and some variant characters like 於 vs. 乎, 儀 vs. 義, 隆 vs. 降, 暉潤 vs. 光炎, the inversion 人君 vs. 君人, and the introduction 傳曰 in *Han shi wai zhuan*, the *Xun zi* and the *Han shi wai zhuan* versions are textually identical and, therefore, must derive from a common ancestor.<sup>15</sup>

### 1.1.2 Parallel texts

Parallel texts are analogous stories sharing the same motif yet using a different wording. They must have an independent textual origin. We might differentiate between invariable parallel texts whose subject, plot, structures, *dramatis*

<sup>14</sup> *Xun zi ji jie* 16: 194; Knoblock II, 1990: 239.

<sup>15</sup> Note that whether the *Xun zi* is this ancestor from which the *Han shi wai zhuan* copies, or whether both versions copy from earlier versions is not relevant for our argument.

*personae*, etc. are the same and variable parallel texts in which any or some of these are changed.

A few examples may illustrate this.

### 1.1.2.1 Cicada in danger

Pericope 20.8 of the received *Zhuang zi* relates the famous story of Zhuang Zhou wandering in the park of Diaoling. Its first part reads as follows:<sup>16</sup>

莊周游於雕陵之樊，睹一異鵠自南方來者。翼廣七尺，目大運寸，感周之類，而集於栗林。莊周曰：「此何鳥哉！翼殷不逝，目大不睹。」蹇裳躩步，執彈而留之。睹一蟬，方得美蔭而忘其身。螳螂執翳而搏之，見得而忘形；異鵠從而利之，見利而忘其真。莊周怵然曰：「噫！物固相累，二類相召也。」捐彈而反走，虞人逐而誅之。

Watson translates it thus:

Zhuang Zhou was wandering in the park at Diaoling when he saw a peculiar kind of magpie that came flying along from the south. It had a wingspread of seven feet and its eyes were a good inch in diameter. It brushed against Zhuang Zhou's forehead and then settled down in a grove of chestnut trees. "What kind of bird is that!" exclaimed Zhuang Zhou. "Its wings are enormous but they get it nowhere; its eyes are huge but it can't even see where it's going!" Then he hitched up his robe, strode forward, cocked his crossbow and prepared to take aim.

As he did so, he spied a cicada that had found a lovely spot of shade and had forgotten all about [the possibility of danger to] its body. Behind it, a praying mantis, stretching forth its claws, prepared to snatch the cicada, and it too had forgotten about its own form as it eyed its prize. The peculiar magpie was close behind, ready to make off with the praying mantis, forgetting its own true self as it fixed its eyes on the prospect of gain.

Zhuang Zhou, shuddering at the sight, said, "Ah! – things do nothing but make trouble for each other – one creature calling down disaster on another!" He threw down his crossbow, turned about, and hurried from the park, but the park keeper [taking him for a poacher] raced after him with shouts of accusation.<sup>17</sup>

Into the frame narrative with Zhuang Zhou as its protagonist are integrated various animals beginning with a cicada and ending with a magpie trying to catch the creature ahead (in the above translation emphasized by a frame). Zhuang Zhou in his turn aims at the magpie before he himself has to flee. The *Han shi wai zhuan* contains an anecdote of King Zhuang of Chu who is criticized by Sunshu Ao for planning an attack on the state of Jin. The main part of his argument consists of the very same motif of animals trying to catch each other

<sup>16</sup> *Zhuang zi* 20.61.

<sup>17</sup> Watson 1968: 218, Romanization adapted to *pinyin*.

and thereby not being aware of the dangerous situation they themselves are in, as even the titmouse becomes the target of a boy:<sup>18</sup>

楚莊王將興師伐晉，告士大夫曰：「敢諫者死無赦。」孫叔敖曰：「臣聞：畏鞭箠之嚴，而不敢諫其父，非孝子也；懼斧鉞之誅，而不敢諫其君，非忠臣也。」於是遂進諫曰：「臣園中有榆，其上有蟬，蟬方奮翼悲鳴，欲飲清露，不知螳螂之在後，曲其頸，欲攫而食之也；螳螂方欲食蟬，而不知黃雀在後，舉其頸，欲啄而食之也；黃雀方欲食螳螂，不知童子挾彈丸在下，迎而欲彈之；童子方欲彈黃雀，不知前有深坑，後有窟也。此皆言前之利，而不顧後害者也，非獨昆蟲眾庶若此也，人主亦然。君今知貪彼之土，而樂其士卒。」（楚）國不（怠）（殆），而晉國以寧，孫叔敖之力也。

In Schaberg's translation:

King Zhuang of Chu was about to muster the army for an attack on Jin. He told his retainers and ministers: "Whosoever dares to remonstrate will die without hope of pardon." Sunshu Ao said: "I have heard that one who fears the severity of the lash and dares not remonstrate with his father is not a filial son, and that one who is terrified of punishment by the axe and dares not remonstrate with his ruler is not a loyal minister."

So he entered and remonstrated, saying:

"In my garden there is an elm. In it there was a cicada, which was just stirring its wings and buzzing mournfully and was about to sip the clear dew, but did not know that there was a mantis behind it bending its neck and preparing to seize and eat it. The mantis, about to eat the cicada, did not know that there was a titmouse behind it stretching its neck and preparing to snap it up and eat it. The titmouse, about to eat the mantis, did not know that there was a boy grasping a pellet-bow below, creeping up and preparing to shoot it. The boy, about to shoot the titmouse, did not know that there was a deep trench in front of him and a pit behind.

All these considered the gain in front of them without giving a thought to the harm behind them. It is not only insects and commoners who are like this. The people's ruler is also like this. Now, my lord knows about lusting after his land and delighting in his fighting men."

That the state did not face peril and Jin had peace was due to the force of Sunshu Ao.<sup>19</sup>

The motif of both parallel texts is the same: a series of beings are presented each of which tries to catch another one, not knowing that it, too, is in danger. Both texts contain a cicada and a mantis. The *Zhuang zi* then has a magpie trying to seize the mantis, whereas the *Han shi wai zhuan* has a titmouse trying to snap the mantis. The human being aiming at the last mentioned animal is Zhuang Zhou in the first text but an anonymous boy in the second. The danger awaiting Zhuang Zhou is the park keeper racing after him while the boy is not threatened by any human being, rather he may fall into the

<sup>18</sup> *Han shi wai zhuan* 10.21.

<sup>19</sup> Schaberg 2005: 207.



deep trench in front of him or the pit behind. Finally, Zhuang Zhou is throwing down his crossbow, in order to hurry from the park whereas the boy keeps preparing to shoot the titmouse. Also the scene of action is different: in the *Zhuang zi* it is a grove of chestnut trees, in the *Han shi wai zhuan* it is an elm tree in a private garden. It would be futile to present both texts in a synopsis as only a few single characters would match. So, clearly both texts must belong to two different textual traditions, going back to different archetypes.

### 1.1.2.2 Refusing office

Another example of parallel texts is the motif of refusing office, occurring both in the *Zhuang zi* and the *Shi zi* 尸子 of ca. 330 BC. Among the fragments of the *Shi zi* the following pericope occurs:<sup>20</sup>

夷逸者,夷詭諸之裔.或勸其仕.曰:吾譬則牛,寧服輓以耕於野,不思被繡入廟而為犧.

As for Yi Yi, he was a descendant of Yi Guizhu. Somebody advised him to accept an office. [Yi Yi] said: “I am comparable in this case to an ox who rather submits to a yoke in order to plow in the wilderness and does not consider wearing embroidery, entering the ancestral temple and becoming a sacrificial victim.”

The parallel text in the *Zhuang zi* is:<sup>21</sup>

或聘於莊子,莊子應其使曰:子見夫犧牛乎?衣以文繡,食以芻叔,及其牽而入於大廟,雖欲為孤犢,其可得乎!

Someone sent gifts to Zhuang Zi with an invitation to office. Zhuang Zi replied to the messenger in these words: “Have you ever seen a sacrificial ox? They deck him out in embroidery and trimmings, gorge him on grass and beanstalks. But when at last they lead him off into the great ancestral temple, then, although he might wish he could become a lonely calf once more, is it possible?”<sup>22</sup>

Both texts share the same plot: somebody is advising or inviting another person to accept an office. The latter, however, declines the offer or invitation using the simile of an ox preferring not to be decorated with embroidery to become a sacrificial victim. The inviting person is anonymous in both texts, the main character, on the other hand, is different, namely Yi Yi *versus* Zhuang Zi. Also the sacrificial victim’s “desired alternative” differs: to plow in the wilderness or becoming a lonely calf once more. The wording of both texts is so different, that

<sup>20</sup> Fischer 2009: 20.

<sup>21</sup> *Zhuang zi* 32.46.

<sup>22</sup> Watson 1968: 360–361.

they can't be presented in a synopsis. Both texts, therefore, must belong to two different textual traditions, deriving from different archetypes.

### 1.1.2.3 The case of Dongye Ji

An interesting example of parallel versions is the Dongye Ji 東野稷/Dongye Bi 東野畢 story which is transmitted in six different texts. They can be divided into two groups each of which consists of several versions and can be considered as belonging to a textual lineage of its own.

The famous story of Dongye Ji who ruined his horses occurs both in *Zhuang zi* 19 and *Lü shi chun qiu* 19, the latter being longer yet matching *verbatim* the corresponding sentences and phrases of the former, most likely representing an implicit quotation of a pre-Han *Zhuang zi*. Here the *dramatis personae* are the charioteer Dongye Ji, Duke Zhuang 莊公 and Yan He 顏闔 who predicted the breakdown of the horses due to Dongye Ji's mishandling of the animals. We may call this version the "Daoist version".

On the other hand, the same story also appears in *Xun zi* 荀子 (XZ, for short), *Han shi wai zhuan* (HSWZ), *Kong zi jia yu* 孔子家語 (KZJY) and in *Xin xu* 新序 (XX). For the most part, these four texts share *verbatim* identical sentences and may be regarded as the descendents of a "common ancestor text". Here the protagonists are: Dongye Bi, Duke Ding of Lu 魯定公, and Yan Yuan 顏淵 alias Yan Hui 顏回. We may call this version the "Ruist (or Confucian) version".

The story in the XZ/KZJY/HSWZ/XX-tradition is phrased in an entirely different way than the *Zhuang zi*/*Lü shi chun qiu*-tradition. Therefore, we can say that the Ruist or Confucian version is a parallel text of the Daoist version. These different versions will now be analysed in turn.

First, the *Zhuang zi* pericope is given, followed by its translation:<sup>23</sup>

東野稷以御見莊公，進退中繩，左右旋中規。莊公以為文弗過也。使之鉤百而反。顏闔遇之，入見曰：稷之馬將敗。公密而不應。少焉，果敗而反。公曰：子何以知之？曰：其馬力竭矣，而猶求焉，故曰敗。

Dongye Ji by means of carriage driving introduced [himself] to Duke Zhuang. He drove back and forth as straight as a measuring line and circled to left and right as neat as a compassdrawn curve. Duke Zhuang regarded the pattern as unsurpassable, and ordered him to make an [other] hundred circuits and then return. Yan He encountered him, entered [the palace] and visited [the duke], saying: "Ji's horses are going to break down." The duke was silent and did not reply. In a little while [Dongye Ji] returned, [his horses] having in fact broken down. The duke said: "How did you know it [beforehand]?" [Yan He] said: "The strength of the horses being all gone he still asked them [to go on] – that's why I said they would break down."

<sup>23</sup> *Zhuang zi* 19.59; also see Watson 1968: 206.

Now the *Lü shi chun qiu* text is shown:<sup>24</sup>

東野稷以御見莊公，進退中繩，左右旋中規。莊公曰：善，以為造父不過也，使之鉤百而少及焉。顏闔入見。莊公曰：子遇東野稷乎？對曰：然。臣遇之。其馬必敗。莊公曰：將何敗？少頃，東野之馬敗而至。莊公召顏闔而問之曰：子何以知其敗也？顏闔對曰：夫進退中繩，左右旋中規。造父之御無以過焉。鄉臣遇之，猶求其馬，臣是以知其敗也。

Dongye Ji by means of carriage driving introduced [himself] to Duke Zhuang. He drove back and forth as straight as a measuring line and circled to left and right as neat as a compassdrawn curve. Duke Zhuang said: “Good!” He considered that [even the famous charioteer] Zao Fu would not surpass [it], and ordered him to make an [other] hundred circuits and in a little while to come to [the palace]. Yan He entered [the palace] and visited [the duke]. Duke Zhuang said: “Did you encounter Dongye Ji?” [Yan He] answered: “Yes, your servant encountered him. His horses are going to break down.” Duke Zhuang said: “Why are they going to break down?” In a short time Dongye’s horses had broken down and he arrived [at the palace]. Duke Zhuang summoned Yan He and asked him: “How did you know that his horses would break down?” Yan He replied: “Now he drove back and forth as straight as a measuring line and circled to left and right as neat as a compass-drawn curve. Even the charioteering of a Zao Fu could not be considered to be surpassing it. Your servant encountered him a little while ago and he still asked his horses [to go on]. Therefore your servant knew their collapse.”<sup>25</sup>

It may be useful to have a look at the synopsis of the two texts to which is attached the explicit *Zhuang zi* quotation to be found in *Tai ping yu lan* 太平御覽 (ordered early in 977 and completed probably in 982) 746 and the characters Sima Biao’s commentary refers to:

Synopsis 2: *Lü shi chun qiu* 19, *Zhuang zi* 19, *Sima Biao commentary* (smbc), *Tai ping yu lan* 746

	Position 1	3		15		22		25		29
LSCQ	東野	稷以御見莊公，	進退中繩，	左右旋中規。	莊公曰：善，	以	為造	父不過也，使		
ZZ	東野	稷以御見莊公，	進退中繩，	左右旋中規。	莊公	以	為	文弗過也。使		
smbc		稷						文		
TPYL	東野	稷以御見莊公，	進退中繩，	周旋中規。	莊公		為造	父弗過也！		
	Position 30	31	35		41					53
LSCQ	之	鉤百而少	及焉。	顏闔	入見。	莊公曰：子遇東野稷乎？對				曰：
ZZ	之	鉤百而	反。	顏闔遇之，	入見					曰：
smbc		鉤百	反							
TPYL				顏闔遇之，	入見					曰：

<sup>24</sup> *Lü shi chun qiu* 19: 247.

<sup>25</sup> For a differing translation see Knoblock/Riegel 2000: 495.

<i>Position</i> 54	58	64	69	73	79
LSCQ 然。臣遇之。	其	馬必敗。莊	公曰：將何敗？	密而不應。	少頃，東野之馬
ZZ	稷之	馬將敗。	公	密而不應。	少焉，
TPYL	稷之	馬將敗。	公	密而不應。	少焉， 果
<i>Position</i> 80	84	91	102	111	
LSCQ 敗而至。莊	公召顏闔而問之	曰：子何以知其敗也？	顏闔對	曰：夫進退中繩，左右旋中	
ZZ 敗而反。	公公	曰：子何以知之？	曰：	曰：	
TPYL 敗而反。	公公	曰：子何以知之？	曰：	曰：	
<i>Position</i> 112	125	131	136	140	
LSCQ 規，造父之御，無以過焉。鄉臣遇之，		猶求其馬，臣	是以知其		
ZZ		其馬力竭矣，而猶求焉，	故	曰：	
TPYL		其馬力竭矣，而猶求焉，	故	故	曰：
<i>Position</i> 141					
LSCQ 敗也。					
ZZ 敗。					
TPYL 敗。					

As the synopsis shows, both texts belong to the same textual lineage, the received *Zhuang zi* version being somewhat abridged. As the “original” *Zhuang zi* must be older than the *Lü shi chun qiu* (the latter on occasion explicitly quotes the former), it is most likely, that here the *Lü shi chun qiu* implicitly quotes the *Zhuang zi* of the late third century BC. Note that whereas the *Lü shi chun qiu* on positions 24 and 25 has the name Zao Fu 造父, the *Zhuang zi* has *wen* 文 (“pattern”). According to Lu Deming’s *Jing dian shi wen*, Sima Biao has commented the phrase 文弗過也 (“the pattern is unsurpassable”) as *wei guo zhi zu zhi wen ye* 謂過織組之文也 (“its meaning is: surpassing the pattern of a woven silk band”). The change from Zao Fu to *wen* could be explained as a two-step process: first, a scribe erroneously wrote *wén* 文 for *fū* 父 (depending on the writing style, both characters may look quite similar, so that one can easily be mistaken for the other). In a second step, the character *zào* 造 was lost. These changes must have taken place after the compilation of the *Lü shi chun qiu* but before Sima Biao produced his commentary. Surprisingly, the *Tai ping yu lan*, explicitly quoting *Zhuang zi*, does not have the character *wén* but still preserves Zao Fu. Those members of the *Tai ping yu lan* staff who were responsible for this entry either must have had access to an early *Zhuang zi* edition or, more likely, have copied a source which itself had relied on an early edition of the *Zhuang zi*.

Although relating a similar Dongye Bi story, the XZ/KZJY/HSWZ/XX-version is quite different from the *Zhuang zi/Lü shi chun qiu*-version. This can be seen in, e. g., the text of the *Han shi wai zhuan* which together with Hightower’s translation is now presented:<sup>26</sup>

<sup>26</sup> *Han shi wai zhuan* 2.12, Hightower 1952: 49 ff.

顏淵侍（坐）魯定公于臺，東野畢御馬于臺下。定公曰：善哉！東野畢之御也。顏淵曰：善則善矣！（雖然）其馬將佚矣。定公不說，以告左右曰：（吾）聞（之）君子不譖人，君子亦譖人乎？顏淵退，俄而、廋人以東野畢（之）馬佚聞矣。定公揭席而起，曰：趣駕召顏淵。顏淵至，定公曰：鄉寡人曰：善哉！東野畢之御也。吾子曰：善則善矣！然（則）（其）馬將佚矣。不識吾子以何知之？顏淵曰：臣以政知之。昔者舜工於使人，造父工於使馬，舜不窮其民，造父不極其馬，是以舜無佚民，造父無佚馬。今東野畢之上車執轡，御體正矣，周旋步驟，朝禮畢矣，歷險致遠，馬力殫矣，然猶策之不已，所以知佚也。定公曰：善。可少進。顏淵曰：獸窮則齧，鳥窮則啄，人窮則詐。自古及今，窮其下能不危者，未之有也。詩曰：執轡如組，兩驂如舞。善御之謂也。定公曰：寡人之過矣。

Yan Yuan was sitting by Duke Ding of Lu on a raised platform, when Dongye Bi drove his horse [and chariot] past. Duke Ding said: "How well Dongye Bi drives!" Yan Yuan said: "He is all right, but his horses are going to run away." Duke Ding was not pleased and said to his retainers: "I had heard that a superior man does not slander people; does he then really engage in slander?" Yan Yuan withdrew. Suddenly a man from the Imperial Stables [came and] announced that Dongye Bi's horses had run away. Duke Ding... (?) the mat and got up, saying: "Quickly send a chariot to call back Yan Yuan." When Yan Yuan arrived, Duke Ding said: "A little while ago I said: 'How well Dingye Bi drives', and you said: 'He is all right, but his horses are going to run away'. How did you know it?" Yan Yuan said: "From [principles of] government I knew it. In olden times Shun was expert in handling people and Zaofu was expert in handling horses. Shun did not wear out his people and Zaofu did not drive his horses to the limit. Hence, under Shun the people did not break down, and under Zaofu, horses did not run away. Now as to Dongye Bi's driving, in mounting the chariot and holding the bridle, his style of managing was correct. In his evolutions and rushes, he was in complete accord with court ceremony. But from going through danger and travelling far he had exhausted the horses's strength; yet still he beat them without cease. Therefore I knew they would run away." Duke Ding said: "Good. Can you drive the point a little further?" Yan Yuan said: "If an animal is pushed to extremity, he will bite; in the same circumstances a bird will peck, and a man will practice treachery. Since antiquity to the present day it has never happened that reducing the people to extremity has not been dangerous. The *Ode* says: 'The reins are in his grasp like ribbons, while the two outside horses move like dancers.' Good driving is illustrative of this." Duke Ding said: "I was at fault."

The synopsis of the four texts belonging to this tradition reads as follows:

Synopsis 3: Han shi wai zhuan,<sup>27</sup> Xun zi,<sup>28</sup> Kong zi jia yu,<sup>29</sup> Xin xu<sup>30</sup>

HSWZ	顏淵侍坐	魯	定公于臺，東野畢御馬于臺下。			
XX	顏淵侍	魯	定公于臺，東野畢御馬于臺下。			
XZ			定公	問於顏淵曰：子亦聞東野畢之善馭乎？		
KZJY		魯	定公	問於顏回曰：子亦聞東野畢之善御乎？		
HSWZ	定公曰：善哉！東野畢之御也。	顏淵	曰：善則善矣！	其馬將	佚	
XX	定公曰：善哉！東野畢之御。	顏淵	曰：善則善矣，雖然，	其馬將	失。	
XZ		顏淵	曰：善則善矣，雖然，	其馬將	失。	
KZJY		對對	曰：善則善矣，雖然，	其馬將必	佚。	

<sup>27</sup> Han shi wai zhuan 2.12.

<sup>28</sup> Xun zi ji jie 31: 358.

<sup>29</sup> Kong zi jia yu 5: 45.

<sup>30</sup> Xin xu 5: 7b.

HSWZ 矣。 定公 不說，以 告左右曰： 聞 君子不譖人， 君子亦 譖人  
 XX 定公 不悅，以 告左右曰：吾 聞之 君子不譖人， 君子亦 譖人  
 XZ 定公 不悅，入 謂左右曰： 謂左右曰： 君子固 譖人  
 KZJY 定公色 不悅， 謂左右曰： 謂左右曰： 君子固有 譖人

HSWZ 乎？顏淵 退， 俄 而、 廐人 以 東野  
 XX 乎？顏淵不悅，歷階而 去。 須臾 而 校來謁， 曰： 東野  
 XZ 乎！ 三日 而 牧來訴之， 曰： 東野  
 KZJY 也。顏回 退後 三日， 三日， 曰： 東野

HSWZ 畢 馬佚聞矣。 定 公 揭席而起， 曰： 趣駕  
 XX 畢 馬敗聞矣， 定 公 躐席而起， 曰： 趣駕  
 XZ 畢之 馬失。 兩驂列， 兩服入廐。 定 公 越席而起， 曰： 趣駕  
 KZJY 畢之 馬佚， 兩驂曳， 兩服入于。 定 公 聞之， 越席而起， 促駕

HSWZ 召顏淵。 顏 淵至， 定 公曰： 鄉 寡人曰： 善哉！ 東野畢之  
 XX 請顏淵。 顏 淵至， 定 公曰： 向 寡人曰： 善哉， 東野畢  
 XZ 召顏淵！ 顏 淵至， 定 公曰： 前日 寡人問吾子，  
 KZJY 召顏回。 回至， 公曰： 前日 寡人問吾子 以 東野畢之

HSWZ 御也。 吾子曰： 善則善矣！ 然， 則馬將佚矣。 不識吾子以何知之？  
 XX 御也。 吾子曰： 善則善矣， 雖 然， 其馬將失矣。 不識吾子何以知之？  
 XZ 吾子曰： 東野畢之駃 善則善矣， 雖 然， 其馬將失。 不識吾子何以知之？  
 KZJY 御， 而子曰： 善則善矣， 其馬將佚， 不識吾子奚以知之？

HSWZ 顏淵 曰： 臣 以政知之。昔者， 舜工於使人， 造父工於使馬， 舜不窮其民，  
 XX 也？ 顏淵 曰： 臣 以政知之。昔者， 舜工於使人， 造父工於使馬。舜不窮其民，  
 XZ 顏淵對 曰： 臣 以政知之。昔 舜巧於使民， 而造父巧於使馬； 舜不窮其民，  
 KZJY 顏回對 曰： 以政知之。昔者， 帝 舜巧於使民， 造父巧於使馬， 舜不窮其民

HSWZ 造父不極其馬， 是以舜無佚民， 造父無佚馬。 今東野畢 之 上車  
 XX 造父不盡其馬， 是以舜無佚民， 造父無佚馬。 今東野 之御也， 上馬  
 XZ 造父不窮其馬； 是以舜無佚民， 造父無佚馬。 今東野畢 之馭， 上車  
 KZJY 力， 造父不窮其馬力， 是以舜無佚民， 造父無佚馬。 今東野畢 之御也， 升馬

HSWZ 執轡， 御體正矣， 周旋步驟， 朝禮畢矣， 歷險致遠， 馬力殫矣， 然 猶 策之 不  
 XX 執轡， 御體正矣， 周旋步驟； 朝禮畢矣， 歷險致遠， 而 馬力殫矣， 然 求 不

XZ 執轡， 御體正矣； 步驟馳騁， 朝禮畢矣； 歷險致遠， 馬力盡矣； 然 猶 求馬 不  
 KZJY 執轡， 御體正矣， 步驟馳騁， 朝禮畢矣， 歷險致遠， 馬力盡矣， 然而猶乃 求馬 不

HSWZ 已， 所以 知 佚也。 定 公曰： 善。  
 XX 已， 是以 知其 失也。 定 公曰： 善，  
 XZ 已， 是以 知之也。 定 公曰： 善，  
 KZJY 已， 臣以此 知之。 公曰： 善！ 誠若吾子之言也， 吾子之言， 其義大矣，

HSWZ 可 少進。 顏淵 曰： 獸窮則齧， 鳥窮則啄，  
 XX 可 少進與？ 顏淵 曰： 獸窮則觸， 鳥窮則喙，  
 XZ 可得 少進乎？ 顏淵對 曰： 臣聞之， 鳥窮則啄， 獸窮則攫，  
 KZJY 願 少進乎。 顏回 曰： 臣聞之， 鳥窮則啄， 獸窮則攫，

HSWZ 人窮則詐。 自古及今， 窮其下 能不危者， 未之有也。  
 XX 人窮則軸。 自古及今， 有 窮其下 能無危者， 未之有也。  
 XZ 人窮則詐。 自古及今， 未 有 窮其下而 能無危者也。  
 KZJY 人窮則詐， 馬窮則佚， 自古及今， 未 有 窮其下而 能無危者也。

HSWZ

XX

XZ

KZJY 公悅，遂以告孔子。孔子對曰：夫其所以為顏回者，此之類也，豈足多哉。

詩曰：執轡如

詩曰：執轡如

HSWZ 組，兩驂如舞。善御之謂也。定公曰：

寡人之過矣。

XX 組，兩驂如舞。善御之謂也。定公曰：善哉！

寡人之過也。

XZ

KZJY

Without going into any details, it should be obvious that the four texts share quite a few sentences *verbatim*, which suggests that they must descend from a “common ancestor text”. Furthermore, *Han shi wai zhuan* and *Xin xu* share phrases (marked green) that are absent in both *Xun zi* and *Kong zi jia yu* – e. g., at the very beginning but also the explicit *Shi jing* quotation at the end. On the other hand, *Xun zi* and *Kong zi jia yu* share some characteristics (marked yellow) that are absent in *Han shi wai zhuan* and *Xin xu*. However, *Kong zi jia yu* differs from *Xun zi* (marked blue) in that at the end of its text it introduces Master Kong who does not appear in the corresponding *Xun zi* pericope.

Therefore, this group of four variants of the XZ/KZJY/HSWZ/XX-version can be divided into two subgroups. The provisional stemma would be:

*Stemma of the Han shi wai zhuan/Xin xu/Xun zi/Kong zi jia yu-versions*

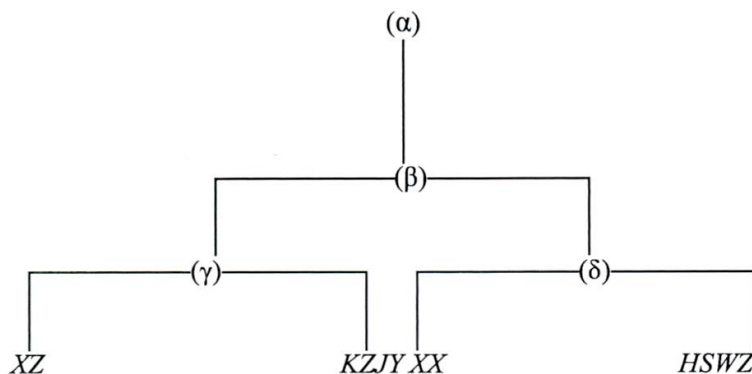

### 1.1.3 Explicit quotations

“Explicit quotations” are quotations whose original sources are explicitly given. They have the form of “[Text] *Such-and-such* says: [...]”. Unless there is evidence of the contrary, these attributions have to be trusted *in dubio pro*.

It may be useful to give an example. *Tai ping yu lan* has the entry:<sup>31</sup>

莊子曰：井魚不可以語海，夏蟲不可以語冰。

The *Zhuang zi* says: “A well fish cannot talk about the ocean; a summer insect cannot talk about ice.”

The received text has the following phrases:<sup>32</sup>

井蛙不可以語於海者，拘於虛也；夏蟲不可以語於冰者，篤於時也。

That a well frog cannot talk about the ocean is [due to his] being limited by [his] space. That a a summer insect cannot talk about ice is [due to his] being bound to [his] season.<sup>33</sup>

Despite the differences in individual characters, which may be important for textual criticism, and despite its abridgement, this is a clear case of the *Tai ping yu lan* quoting some version of the *Zhuang zi*, which is corroborated by the corresponding phrases of the *textus receptus*.

However, there are cases of explicit quotations for which there exist no correspondences in the received text – they are representatives of lost parts of the *Zhuang zi*. An example is to be found in Li Shan’s 李善 (?–689) commentary to Xiao Tong’s 蕭統 (501–531) *Wen xuan* 文選:<sup>34</sup>

莊子曰：尹儒學御，三年而無所得。夜夢受秋駕。明日往朝師，師曰：今將教子以秋駕。  
司馬彪曰：秋駕，法駕也。

The *Zhuang zi* says: “Yin Ru studied charioteering. During three years he didn’t get anywhere. One night he dreamt of receiving ‚[the art of] autumn driving’. The next day he went to visit [his] teacher. The teacher said: ‚Now I am about to instruct you by means of ‚[the art of] autumn driving.’” Sima Biao says [in his commentary]: “‘Autumn driving’ is driving [according to certain] rules.”

That this explicit quotation of a lost part of *Zhuang zi* indeed has once belonged to the *Zhuang zi* is confirmed by Sima Biao’s accompanying comment.<sup>35</sup> Sima Biao is known for his *Zhuang zi* commentary, now lost, to be dated after AD 265 and written at a time before Guo Xiang severely abridged the *Zhuang zi*.<sup>36</sup> An independent corroboration for the existence of a *Zhuang zi* pericope mentioning the term “autumn driving” is provided by Yan Shigu 顏師古 (581–645) in his commentary to

<sup>31</sup> *Tai ping yu lan* 22: 1a.

<sup>32</sup> *Zhuang zi* 17.5.

<sup>33</sup> Also see Watson 1968: 175 f.

<sup>34</sup> Comm. *Wen xuan* 6: 132b. This example will be further discussed below, see 4.1.2.

<sup>35</sup> This example will be treated in more detail below.

<sup>36</sup> See below, 3.5.



the *Han shu* 漢書 (completed in 641): 師古曰: 莊子有秋駕之法者 [...] (“Yan Shigu says: ‘[In] the *Zhuang zi* there are the rules of autumn driving’ [...]).<sup>37</sup>

#### 1.1.4 Implicit quotations

“Implicit quotations” are phrases or passages included within a given text that are not explicitly marked as quotations but do *verbatim* or largely *verbatim* match phrases or passages of another work which, unless there is evidence for the contrary, has to be regarded as its source. Most scholars so far have termed such phrases or passages “parallel texts”. However, in the present project, the term “parallel text” will be used differently, as has been shown above.

It may be useful to give an example of an implicit quotation. In Lü Buwei’s 呂不韋 (ob. 235 BC) *Lü shi chun qiu* 呂氏春秋 the following pericope is to be found:<sup>38</sup>

中山公子牟謂詹子曰: 身在江海之上, 心居乎魏闕之下, 奈何? 詹子曰: 重生。重生則輕利。中山公子牟曰: 雖知之, 猶不能自勝也。詹子曰: 不能自勝則縱之, 神無惡乎。不能自勝而強不縱者, 此之謂重傷。重傷之人無壽類矣。

Prince Mou of Zhongshan said to Master Zhan: “My body is beside the rivers and seas, but my mind is still below the gate towers of Wei. What should I do about it?” “Value life,” advised Master Zhan. “If you value life, you will disregard material gain.” Prince Mou of Zhongshan said: “I know that, but I cannot control myself.” Master Zhan said: “If you cannot control yourself, then indulge your inclinations. Your spirit will suffer no harm. The injury is twice as great if you cannot control yourself yet do not indulge your inclinations. People who do double injury to themselves are not to be found in the ranks of the long-lived.”<sup>39</sup>

This pericope *verbatim* corresponds to pericope 28.11 of the received *Zhuang zi*:<sup>40</sup>

中山公子牟謂瞻子曰: 身在江海之上, 心居乎魏闕之下, 奈何? 瞻子曰: 重生。重生則利輕。中山公子牟曰: 雖知之, 未能自勝也。瞻子曰: 不能自勝則從, 神無惡乎? 不能自勝而強不從者, 此之謂重傷。重傷之人, 無壽類矣! 魏牟, 萬乘之公子也, 其隱巖穴也, 難為於布衣之士; 雖未至乎道, 可謂有其意矣。

Another implicit quotation of the same pericope appears in Liu An’s 劉安 (ob. 122 BC) *Huai nan zi* 淮南子 (ca. 139 BC):<sup>41</sup>

<sup>37</sup> *Han shu* 22: 1048.

<sup>38</sup> *Lü shi chun qiu* 21: 281.

<sup>39</sup> Adopted from Knoblock/Riegel 2000: 559.

<sup>40</sup> *Zhuang zi* 28.55.

<sup>41</sup> *Huai nan zi* 12: 195.

中山公子牟謂詹子曰：身處江海之上，心在魏闕之下，為之奈何？詹子曰：重生。重生則輕利。中山公子牟曰：雖知之，猶不能自勝。詹子曰：不能自勝，則從之；從之，神無怨乎！不能自勝而強弗從者，此之謂重傷。重傷之人，無壽類矣。

Apart from these implicit quotations, there is also an explicit one extant, to be found in *Tai ping yu lan*<sup>42</sup>

莊子：中山公子牟謂詹子曰：身在滄海之上，心居魏闕之下，奈何？詹子曰：重生，重生則輕利。中山公子牟曰：雖知之，未能自勝也。詹子曰：不能自勝則從，神無惡乎？不能自勝而強不從者，此之謂重陽，重陽人無壽類矣。

Presenting these quotations in parallel, the following synopsis is obtained:

Synopsis 4: *Lü shi chun qiu* 21, *Huai nan zi* 12, *Zhuang zi* 28 and *Tai ping yu lan* 179

LSCQ	中山公子牟謂詹子曰：身在江海之上，心居乎	魏闕之下，	奈何？詹子曰：重生。重生
HNZ	中山公子牟謂詹子曰：身處江海之上，心在	魏闕之下，為之奈何？詹子曰：重生。重生	
ZZ	中山公子牟謂詹子曰：身在江海之上，心居乎	魏闕之下，	奈何？詹子曰：重生。重生
TPYL	中山公子牟謂詹子曰：身在滄海之上，心居	魏闕之下，	奈何？詹子曰：重生，重生

LSCQ	則輕利。中山公子牟	曰：雖知之，猶不能自勝也。	詹子曰：不能自勝，則縱之，
HNZ	則輕利。中山公子牟	曰：雖知之，猶不能自勝。	詹子曰：不能自勝，則從之；從之，
ZZ	則利輕。中山公子牟	曰：雖知之，未能自勝也。	詹子曰：不能自勝，則從，
TPYL	則輕利。中山公子	曰：雖知之，未能自勝也。	詹子曰：不能自勝，則從，

LSCQ	神無惡乎。不能自勝而強不縱者，此之謂重傷。重傷之	人，無壽類矣。
HNZ	神無怨乎！不能自勝而強弗從者，此之謂重傷。重傷之	人，無壽類矣。
ZZ	神無惡乎？不能自勝而強不從者，此之謂重傷。重傷之	人，無壽類矣！魏牟，萬乘之公子也，
TPYL	神無惡乎？不能自勝而強不從者，此之謂重陽，重陽	人，無壽類矣。

LSCQ  
HNZ  
ZZ 其隱巖穴也，難為於布衣之士；雖未至乎道，可謂有其意矣。  
TPYL

If differences in individual characters are disregarded – they will have to be considered in the forthcoming critical edition – the degree of agreement of the four texts is striking.<sup>43</sup> However, the pericope in the received *Zhuang zi* is longer than the other three versions, furthermore, these additional phrases are

<sup>42</sup> *Tai ping yu lan* 179: 2b.

<sup>43</sup> The possibility that these *Lü shi chun qiu*, *Huai nan zi* and *Zhuang zi* pericopes all may derive from a common, unknown earlier source can, of course, not be ruled out but is not relevant for our purposes.

significantly missing in the explicit *Zhuang zi* quotation in *Tai ping yu lan*. In fact, they serve as an explanation of the preceding story, as the translation shows:

魏牟，萬乘之公子也，其隱巖穴也，難為於布衣之士；雖未至乎道，可謂有其意矣。

Wei Mou was a prince of a state of ten thousand chariots, and it was more difficult for him to retire and live among the cliffs and caves than for an ordinary person. Although he did not attain the Way, we may say that he had the will to do so.<sup>44</sup>

These additional phrases in the *textus receptus* must be a comment added by a later hand which at some time during the transmission of the text became integrated into the main text. Neither in the implicit quotation in *Lü shi chun qiu* 21 nor in that of *Huai nan zi* 12 do these sentences occur. It cannot be said, given the present state of knowledge, whether this comment was made by Guo Xiang or somebody else. Lu Deming comments its expression 萬乘. However, as he does not explicitly distinguish between main text and Guo Xiang's commentary in his *Jing dian shi wen*, it may well be that these additional sentences originally belonged to Guo Xiang's commentary. Note that the received *Zhuang zi* text lacks any explicit Guo Xiang commentary to these sentences.

## 2 Earliest evidence

### 2.1 Earliest textual evidence of the existence of the *Zhuang zi*

The earliest explicit quotation of the *Zhuang zi* dates no further back than to the Qin dynasty and is to be found in Lü Buwei's 呂不韋 (ob. 235 BC) *Lü shi chun qiu* 呂氏春秋 (of 239 BC). It appears in pericope 13.3.4:<sup>45</sup>

莊子曰：以瓦投者翔，以鉤投者戰，以黃金投者殆。其祥一也，而有所殆者，必外有所重者也。外有所重者，泄蓋內掘。

The *Zhuang zi* says: "Play for tiles and you soar; play for belt-hooks and you become combative; play for gold and you are flustered. Although your luck is the same in each of the games, the reason you become flustered must be the value you place on external things. Valuing external things makes one become clumsy within."<sup>46</sup>

<sup>44</sup> Watson 1968: 318.

<sup>45</sup> *Lü shi chun qiu* 13: 129.

<sup>46</sup> Knoblock/Riegel 2000: 288.

This passage occurs, with some variant characters,<sup>47</sup> in pericope 19.4 of the *textus receptus*:<sup>48</sup>

以瓦注者巧，以鈎注者憚，以黃金注者殫。其巧一也，而有所矜，則重外也。凡外重者內拙。

The *Lü shi chun qiu* thus gives us a *datum ante quem* for the compilation of the *Zhuang zi*. Perhaps around the same time, Xun Qing 荀清 (?335 – ?238 BC) in his *Xun zi* 荀子, criticizing some philosophers for their limitations (“in the past, there was the blindness of the guest-retainers, of which the disordered schools are examples”, 昔賓孟之蔽者，亂家是也), says about the philosophers Hui Shi and Zhuang Zhou:<sup>49</sup>

惠子蔽於辭而不知實。莊子蔽於天而不知人。

Master Hui being blinded by argumentation was not knowledgeable about reality. Master Zhuang being blinded by *tian* (heaven/nature) was not knowledgeable about men.

In Eastern Han times the *Han shi wai zhuan* copied Xun Qing’s passage, although condensing it, changed some of the philosophers’ names listed yet retained Zhuang Zhou.<sup>50</sup>

Liu An’s 劉安 (ob. 122 BC) *Huai nan zi* 淮南子 (of ca. 139 BC) contains the following explicit quotation:<sup>51</sup>

故莊子曰：小年不及大年，小知不及大知，朝菌不知晦朔，蟪蛄不知春秋。

Therefore the *Zhuang zi* says: “Little understanding cannot come up to great understanding; the shortlived cannot come up to the long-lived; the morning mushroom knows nothing of twilight and dawn; the summer cicada knows nothing of spring and autumn.”<sup>52</sup>

In the *textus receptus*, this passage reads:<sup>53</sup>

小知不及大知，小年不及大年。奚以知其然也？朝菌不知晦朔，蟪蛄不知春秋，此小年也。

<sup>47</sup> For a synopsis including more quotations of this passage, see below, synopsis 8.

<sup>48</sup> *Zhuang zi* 19.25.

<sup>49</sup> *Xun zi ji jie* 21: 262; Knoblock III, 1994: 102.

<sup>50</sup> *Han shi wai zhuan* 4.22, Hightower 1952: 145–146.

<sup>51</sup> *Huai nan zi* 12: 205.

<sup>52</sup> For a slightly differing translation, cf. Major et al. 2010: 472.

<sup>53</sup> *Zhuang zi* 1.10.

The shortlived cannot come up to the long-lived; little understanding cannot come up to great understanding; the morning mushroom knows nothing of twilight and dawn; the summer cicada knows nothing of spring and autumn. They are the shortlived.<sup>54</sup>

The synopsis of both passages reads like this:

Synopsis 5: *Huai nan zi* 12 and *Zhuang zi* 1

<i>Position</i> 1	5	11	17	29	33
HNZ	故莊子曰：	小年不及大年，	小知不及大知，		朝菌不知晦
ZZ		小知不及大知，	小年不及大年。	奚以知其然也？	朝菌不知晦
<i>Position</i> 34		41	44		
HNZ	朔，	蟪蛄不知春秋。			
ZZ	朔，	蟪蛄不知春秋，	此小年也。		

Although the first phrase in *Huai nan zi* (positions 5–10) is transposed in *Zhuang zi* (positions 17–22), both passages are virtually identical apart from the fact that *Huai nan zi* abridges the passage by omitting the sentences “how do I know this is so?” (奚以知其然也?)(*Zhuang zi* positions 23–28) and “they are the short-lived” (此小年也)(*Zhuang zi* positions 41–44).

From the late Warring States period to the first half of the Eastern Han dynasty we thus have, though scanty, evidence for the existence of a text called *Zhuang zi* and a Master called Zhuang Zhou.

## 2.2 Archaeological evidence

Of particular interest are all texts discovered in archaeological excavations. Some may have been lost a long time ago and were thus entirely unknown before they were brought to the light. Some may have been known only through quotations. Some may have been transmitted indeed, their received versions, however, may have been printed more than a millenium later. In any case, such mss. are by far closer to the original than any other version being it quoted or received and are thus vital for textual criticism.

Archaeologically discovered mss. are also important from another point of view. They mark the geographical locations where a given text was available during the time it was entrusted to the soil, thus complementing pieces of information found in other sources. According to Lü Buwei’s biography in the *Shi ji*, his *Lü shi chun qiu* which, as we have seen, contains the earliest direct

<sup>54</sup> Watson 1968: 30.

quotation of the *Zhuang zi*, was most certainly compiled in Qin's capital Xianyang, as – so the anecdote goes – he had laid the text open for general inspection at its market gate.<sup>55</sup> This may have happened around 239 BC. By 167 BC a whole chapter of the *Zhuang zi* was buried together with its owner in Zhangjiashan, Jiangling (Hubei), or more than 500 km south-east of Xianyang, and, two years later, at least parts of the *Zhuang zi* were put into a tomb at Shuanggudui, Fuyang (Anhui), more than 600 km west-south-west of Xianyang and roughly 450 km north-east of Zhangjiashan. May we infer from this that at that time at least parts of the *Zhuang zi* were available within an area comparable in size with that of Portugal plus Wales or the State of Ohio?

### 2.2.1 Zhangjiashan

During the years 1985–1988, Chinese archaeologists excavated two tombs in Zhangjiashan 張家山, Jiangling 江陵, Hubei 湖北. Tomb # 136 which was dated between 173 BC–167 BC<sup>56</sup> yielded a bunch of 829 bamboo strips, including 44 strips – one of which bearing the title “Robber Zhi”<sup>57</sup> – whose “content is complete” (內容完整) and whose “writing and content are basically identical with the extant edition” (與現存版本文字內容基本一致) of the received chapter “Robber Zhi” of the *Zhuang zi*.<sup>58</sup>

As the received version of this chapter contains 3,101 characters, whereas no more than a maximum of 1,760 (44 × 40) characters could have been written on these strips – given their length of 30 centimeters and their width of 0.5 centimeter,<sup>59</sup> and as the “Robber Zhi” pericope proper contains 1,749 characters in the *textus receptus*, this bamboo ms., therefore, cannot represent the complete received “Robber Zhi”. The two pericopes “Zi Zhang asked Man Goude” and “Wu Zu asked Zhi He” of the received chapter must obviously be missing. They must have been included at a later time.

The report seems to indicate that there are textual differences which will be of considerable importance from the point of view of textual criticism. As these

55 *Shi ji* 85: 2510; translated in Nienhauser et al. 1994: 314.

56 *Wen wu* 1992.9: 10.

57 The character *zhi* is different from the received one.

58 *Wen wu* 1992.9: 4.

59 Strips # 10 and # 11 of the *Wen wu* article, the only strips of the *Zhuang zi* cache that were photographically reproduced, according to the *Wen wu* photograph (of rather poor quality), seem to contain 37 characters each.

strips represent the earliest manuscript version so far of any part of the *Zhuang zi*, it is a scientific scandal of the first order that twenty-eight years after their discovery they still have not been published in their entirety, neither as facsimiles nor as transcripts.<sup>60</sup>

Whether or not these “Robber Zhi” strips at the time of their inclusion in the burial represented a separate text or were already part of the *Zhuang zi* we do not know. However, roughly half a century later when Sima Qian compiled his *Shi ji*, this was certainly the case as he explicitly mentioned this bundle title as belonging to the *Zhuang zi*.<sup>61</sup>

The only two *Zhuang zi* strips of the Zhangjiashan cache whose photographs have been published seem to be intact – neither are any *lacunae* to be seen nor are any damages visible and the text on the strips is uninterrupted. The important question now is: how does the text of these strips compare with the received *Zhuang zi*?

Liao’s transcript of strip # 10 reads:<sup>62</sup>

滅且聞之古者禽獸多而人民少於是民毋（？）巢不上以辟之晝日拾杼栗而宿其上名曰有巢

This corresponds to sentences within the received *Zhuang zi* 29.1. Since the transcript cannot be critically assessed as the quality of the photograph of the strips is not good enough, we will not discuss individual characters. What interests us is how far both versions are overall comparable. In the received text, the passage reads:<sup>63</sup>

滅；非以其利大故邪？且吾聞之，古者禽獸多而人少，於是民皆巢居以避之，晝拾橡栗，暮栖木上，故命之曰有巢氏之民。

[...] [their dynasties were cut off and] wiped out. Was this not because the gains they had acquired were so great? Moreover, I have heard that in ancient times the birds and beasts were many and the people few. Therefore the people all nested in the trees in order to escape danger, during the day gathering acorns and chestnuts, at sundown climbing backup to sleep in their trees. Hence they were called the people of the Nest-builder. [...]<sup>64</sup>

<sup>60</sup> For the only two strips that were photographically reproduced Liao Mingchun provided a transcription of their characters in abridged (*sic!*) characters in 2003.

<sup>61</sup> See paragraph 3.2, below.

<sup>62</sup> I have emended 晝 for Liao’s 尺 according to the photograph.

<sup>63</sup> *Zhuang zi* 29.27.

<sup>64</sup> Watson 1968: 327.

The synopsis of both versions reads:

Synopsis 6: Zhangjiashan *strip* # 10, Zhuang zi 29

Liao # 10	滅	且	聞之	古者禽獸多而人民	少	於是
ZZ 29	滅；非以其利大故邪？	且吾	聞之，	古者禽獸多而人	少，	於是
Liao # 10	民毋（？）	巢不上以辟之	晝日	拾杼栗	而宿其上	名
ZZ 29	民皆	巢居以避之。	晝	拾橡栗，	暮栖木上，	故命之
Liao # 10	曰有巢					
ZZ 29	曰有巢氏之民。					

While both versions on the whole seem to be the same (if we disregard character variations), one important difference nevertheless immediately strikes the eye: The phrase *fei yi qi li da gu ye* 非以其利大故邪? (“was this not because the gains they had acquired were so great?”) is missing on the bamboo strip. As no *lacuna* is visible on the photograph of the strip, this phrase must be a later interpolation in the received version. In principle it could have been made at any time between ca. 173 BC and AD 312 when Guo Xiang passed away.<sup>65</sup>

### 2.2.2 Fuyang

Excavations carried out at Shuanggudui 雙古堆, Fuyang 阜陽, Anhui 安徽, in 1977 revealed tomb # 1 which was that of Xiahou Zao 夏侯灶, the second-generation lord of Ruyin 汝陰, who died in 165 BC, and his wife.<sup>66</sup> This tomb is located roughly 450 km north-east of the just discussed Zhangjiashan tomb and almost contemporary with it. As the archaeologists quickly realized, it was robbed already in antiquity. Among the grave goods that were left behind damaged and disordered by the thieves was a series of manuscripts written on bamboo strips. These strips further suffered from a heavy rainstorm during the scientific excavation, when the archaeologists “used a pump to remove mud that had filled the coffin chamber, in the process pumping out also the bamboo strips of the texts, which the long submersion in muddy water had turned into paper-thin sheets, fused together into clumps by ground pressure.”<sup>67</sup> Shaughnessy further summarizing the reports said: “Just the separating of the surviving fragments took almost a year of concentrated work at the Bureau of Cultural Relics in Beijing. To give

<sup>65</sup> Zhangjiashan bamboo strip # 11 in Liao’s transcription also matches the received text, apart from several variant and four missing characters.

<sup>66</sup> Wang Xiangtian and Han Ziqiang 1978.8: 12–31 and 98–99.

<sup>67</sup> Shaughnessy 2001: 8.



some idea of the difficulties encountered, in some cases as an individual strip was peeled off the clump to which it had fused, the ink of the text written on the strip below it adhered to its back, and then had to be read there as a mirror image. That any of the texts have been reconstructed, even in part, is perhaps more surprising than the more than twenty years' wait for some to be published."<sup>68</sup>

Of these strips eight badly-damaged ones were published that contain text which can be matched with the received *Zhuang zi*. While Han Zhiqiang presented rather poor photographs of all of them,<sup>69</sup> better photographs of the strips # 1, # 3, # 6 and # 8 are available in his later book.<sup>70</sup> Han also provided transcripts of these eight fragmented strips<sup>71</sup> which shall now be given here together with the corresponding pericopes of the *textus receptus*:

*Transcripts of eight Fuyang Zhuang zi strips with corresponding pericopes of the received text*

FY #	Han's transcript	received <i>Zhuang zi</i> pericope
1	有乎生莫見	25.9
2	樂與正為正樂	28.15
3	宋元君夜夢丈夫衣被 = 髮窺	26.6
4	之曰是龜	26.6
5	何得曰得龜往視	26.6
6	□事七十兆而無遺筭故不能	26.6
7	剗腸之患	26.6
8	□有所不知而神有	26.6

The five characters of strip # 1 find their counterpart in pericope 25.9<sup>72</sup> of the received *Zhuang zi*, as the following synopsis shows:

FY # 1	有乎生	莫見
ZZ 25	萬物 有乎生而	莫見其根

Similarly, the characters of strip # 2 match phrases of pericope 28.15<sup>73</sup> of the *textus receptus*:

FY # 2	樂與正為正	樂
ZZ 28	樂與政為政，	樂與治為治。

<sup>68</sup> Ibid.

<sup>69</sup> Han/Han 2000: 10–14.

<sup>70</sup> Han Zhiqiang 2004: 70.

<sup>71</sup> Han/Han 2000: 10.

<sup>72</sup> *Zhuang zi* 25.52.

<sup>73</sup> *Zhuang zi* 28.81.

The text of the six strips # 3 – # 8 can be found in the received pericope 26.6.<sup>74</sup> In the following, the whole received pericope is given, the characters corresponding to those of the strips are marked green:

Pericope 26.6 matched with the Fuyang strips (marked **green**)<sup>75</sup>

宋元君夜半而夢人被髮闕阿門，曰：「予自宰路之淵，予為清江使河伯之所，漁者余且得予。」元君覺，使人占之，曰：「此神龜也。」君曰：「漁者有余且乎？」左右曰：「有。」君曰：「令余且會朝。」明日，余且朝。君曰：「漁何得？」對曰：「且之網得白龜焉，箕圓五尺。」君曰：「獻若之龜。」龜至，君再欲殺之，再欲活之，心疑，卜之，曰：「殺龜以卜吉。」乃剖龜，七十二鑽而無遺筮。仲尼曰：「神龜能見夢於元君，而不能避余且之網；知能七十二鑽而無遺筮，不能避剗腸之患。如是，則知有所困，神有所不及也。雖有至知，萬人謀之。魚不畏網而畏鸕鶿。去小知而大知明，去善而自善矣。嬰兒生無石師而能言，與能言者處也。」

This pattern seems to suggest that the whole pericope may have been represented on the Fuyang strips. A proper investigation of the extant strips may hopefully lead to the identification of further fragments and to test this hypothesis.

Turning now to the individual strips and the corresponding phrases of the received *Zhuang zi* as they can be seen in synopsis 7

Synopsis 7: *Texts of the Fuyang strips, phrases of the received Zhuang zi*

FY # 3 ZZ 26	宋元君夜 宋元君夜半而	夢丈夫衣 夢人	被= 髮 被 髮	窺 闕阿門，
FY # 4 ZZ 26	之 使人占之，	曰 曰：	是 此神	龜 龜也。
FY # 5 ZZ 26	君曰：漁	何得 何得？對	曰 曰：且之網	得 龜 往視 得白 龜焉， 箕圓五尺。
FY # 6 ZZ 26	□事 知能	七十兆 七十二鑽	而無遺筮故 而無遺筮，	不能 不能避
FY # 7 ZZ 26	剗腸之患 剗腸之患。如是，則知有所困			
FY # 8 ZZ 26	□ 如是則知	有所不知而 有所困，	神有 神有所不及也。	

<sup>74</sup> *Zhuang zi* 26.24–31.

<sup>75</sup> Han/Han 2000: 10.

This synopsis shows that the text of the bamboo strips and that of the *textus receptus* are sufficiently close to each other to be considered belonging to the same textual tradition. Nevertheless, even in this small text sample the number of variations in wording is remarkable and makes it crystal clear how urgently a publication of all the Fuyang bamboo strips by the Chinese scholars is desired, decades after their discovery, *nota bene*.

### 3 Early transmission

#### 3.1 Was there a Huai nan redaction?

Some scholars assume, although based on rather weak evidence, that a major editorial process already took place at the court of Liu An. Harold Roth formulated it in this way:

[...] I would like to suggest the possibility that the *Chuang Tzu* was compiled at the court of Liu An after the *Huai-nan Tzu* was written, after the Six Classics were formally acknowledged with posts in the bureaucracy [...]. This would approximate the date of compilation of the *Chuang Tzu* to about 130 B.C.E.<sup>76</sup>

This hypothesis has now to be tested. It can be reformulated in a way that allows us to test it: If a passage occurs in all three sources, the *Lü shi chun qiu*, the *Huai nan zi* and the received *Zhuang zi*, and if the *Huai nan zi* wording differs from the *Lü shi chun qiu* but is the same in the received *Zhuang zi*, then it is indeed the *Huai nan zi* redaction on which the received *Zhuang zi* is based. If, however, the received *Zhuang zi* follows *Lü shi chun qiu* against the *Huai nan zi*, then the hypothesis can be rejected.

Let us first consider the earliest extant explicit quotation of *Zhuang zi*, to be found in *Lü shi chun qiu* 13.<sup>77</sup> Fortunately it also occurs as an implicit quotation in *Huai nan zi* 17<sup>78</sup> and it is part of the received *Zhuang zi* 19<sup>79</sup>:

---

<sup>76</sup> Roth 1991: 122.

<sup>77</sup> *Lü shi chun qiu* 13: 129.

<sup>78</sup> *Huai nan zi* 17: 290.

<sup>79</sup> *Zhuang zi* 19.25.

Synopsis 8: Explicit quotation in LSCQ 13, implicit quotation in HNZ 17, and ZZ 19

<i>Position</i>	1	5	10	14	20	25
LSCQ	莊子曰：	以瓦投者翔，	以鉤投者戰，	以黃金	投者殆。其祥一也，	而有所殆者，
HNZ	(…)	以瓦鈇者全，	以金鈇者跋，	以玉	鈇者發，	
ZZ	(…)	以瓦注者巧，	以鉤注者憚，	以黃金	注者殫。其巧一也，	而有所矜，

<i>Position</i>	26	28	35	38	43	48
LSCQ	必	外有所	重者也。	外有	所	重者，
HNZ	是故			重者在外，則	泄蓋	內掘。(…)
ZZ	則	重外也。	凡	外	重者	內為之掘。(…)
						內拙。

It is striking that whole phrases occurring both in the *Lü shi chun qiu* and in the received *Zhuang zi* are missing in the *Huai nan zi*. This means that these phrases as they occur in the received *Zhuang zi* can not be based on the *Huai nan zi*. Apart from this fact, there are also instances of individual characters that are shared by both the *Lü shi chun qiu* and the received *Zhuang zi*, whereas *Huai nan zi* has a different reading. E.g., character *gou* 鉤 (“hook”) at position 7 is *jin* 金 (“metal”) in *Huai nan zi* and the expression *huang jin* 黃金 (“gold”) at positions 12 and 13 has become *yu* 玉 (“jade”) in *Huai nan zi*.

In some instances the received *Zhuang zi* differs from both the *Lü shi chun qiu* and the *Huai nan zi*. These are clear examples of a later development of the *Zhuang zi* text itself. Examples are 所 at position 37 which is lacking in the received *Zhuang zi*, and *jue* 掘 (“hollow”) at position 48 which in the received *Zhuang zi* is *zhuo* 拙 (“clumsy”?).

The next example includes pericope 10.2 of the received *Zhuang zi*,<sup>80</sup> the implicit quotations in pericope 11.4.2 of *Lü shi chun qiu*<sup>81</sup> and in pericope 12.37 of *Huai nan zi*.<sup>82</sup> These passages are presented in the following synopsis:

Synopsis 9: ZZ 10 and implicit quotations in LSCQ 11 and HNZ 12

<i>Position</i>	1	2	7	11	16	20	24
LSCQ		跖之徒問於	跖曰：盜	有道乎？	跖曰：奚啻其	有	道也？夫妄
HNZ		跖之徒問	跖曰：盜亦	有盜乎？	跖曰：奚適其無		道也！夫
ZZ rec. 故		跖之徒問	跖曰：盜亦	有道乎？	跖曰：何適而無	有	道邪？夫妄

<i>Position</i>	25	29	33	38	43	48	50
LSCQ	意關內，	中	藏，	聖也；入先，	勇也；出後，	義也；知時，	智也；分
HNZ	意	而	中	藏者，	聖也；入先者，	勇也；出後者，	義也；
ZZ rec. 意室		中之	藏，	聖也；入先，	勇也；出後，	義也；知可否，	知也；分

<sup>80</sup> *Zhuang zi* 10.10.

<sup>81</sup> *Lü shi chun qiu* 11: 110.

<sup>82</sup> *Huai nan zi* 12: 202.

<i>Position 51</i>	53	58	64	68	74	77
LSCQ	均，仁也。不通此		五者，	而能成大盜者，天下無		
HNZ	均者，仁也；	知可否者，智也。	五者不備，	而能成大盜者，天下無之。		
ZZ rec.	均，仁也。		五者不備	而能成大盜者，天下未之		
<i>Position 78</i>						
LSCQ	有。』					
HNZ		(…)				
ZZ rec.	有也。』	(…)				

This example is somewhat more complicated. Besides the phrase 知可否者，智也 that is transposed in *Huai nan zi* compared with the *Zhuang zi* and its shorter form in *Lü shi chun qiu*, *Huai nan zi* constructs several relative clauses, marked by *zhe* 者, where both *Lü shi chun qiu* and the received *Zhuang zi* have nominal constructions at positions 32, 37, 42, 52. Here *Zhuang zi* follows the *Lü shi chun qiu* against *Huai nan zi*. Also, at positions 45 and 78, *Zhuang zi* and *Lü shi chun qiu* are identical (marked yellow) against *Huai nan zi*. On the other hand, at positions 10, 17, 19, 66, 77, the received *Zhuang zi* is identical with the *Huai nan zi* (marked green) against the *Lü shi chun qiu*. But then, we find instances where *Huai nan zi* follows *Lü shi chun qiu* whereas the received *Zhuang zi* differs (marked blue). This can be best explained by assuming an intermediary text (*Int\**) between the *Lü shi chun qiu* and the *Huai nan zi*. This *Int\** changed some characters of the *Lü shi chun qiu* at certain positions and introduced new characters at others. The *Huai nan zi* mostly followed the *Int\** but introduced a few changes. The received *Zhuang zi* followed *Int\**, changing characters at some locations. We may suggest the following reconstruction for *Int\**:

Suggested provisional reconstruction for the intermediary text *Int\**

跖之徒問跖曰：盜亦有道乎？跖曰：奚適其無道也！夫妄意關中藏，聖也；入先，勇也；出後，義也；知可否，智也；分均，仁也。五者不備，而能成大盜者，天下無之有也。

Pericope 28.11 of the received *Zhuang zi*<sup>83</sup> – which was already discussed above in a different context (see above, 1.1.4) – may serve as a further example, which is to be collated with the implicit *Zhuang zi* quotations in *Lü shi chun qiu* 21.4.4<sup>84</sup> and *Huai nan zi* 12.16.<sup>85</sup> The synopsis of all three passages reads as follows:

<sup>83</sup> *Zhuang zi* 28.55.

<sup>84</sup> *Lü shi chun qiu* 21: 281.

<sup>85</sup> *Huai nan zi* 12: 195.

## Synopsis 10: ZZ 28 and implicit quotations in LSCQ 21 and HNZ 12

LSCQ	中山公子牟謂詹子曰：身 <u>在</u> 江海之上，心 <u>居</u>	<u>乎</u> 魏闕之下，	奈何？詹子曰：重生。
HNZ	中山公子牟謂詹子曰：身處江海之上，心	在魏闕之下，為之	奈何？詹子曰：重生。
ZZ	中山公子牟謂瞻子曰：身 <u>在</u> 江海之上，心 <u>居</u>	<u>乎</u> 魏闕之下，	奈何？瞻子曰：重生。
LSCQ	重生則 <u>輕利</u> 。中山公子牟曰：雖知之， <u>猶</u>	<u>不能自勝也</u> 。	詹子曰：不能自勝，則 <u>縱之</u> ，
HNZ	重生則 <u>輕利</u> 。中山公子牟曰：雖知之， <u>猶</u>	<u>不能自勝</u> 。	詹子曰：不能自勝，則 <u>從之</u> ；
ZZ	重生則利輕。中山公子牟曰：雖知之，	未能自勝也。	瞻子曰：不能自勝，則 <u>從</u> ，
LSCQ	神無 <u>惡</u> 乎。不能自勝而強 <u>不</u> 縱者，此之謂重傷。重傷之人，無壽類矣。		
HNZ	從之，神無怨乎！不能自勝而強 <u>弗</u> 從者，此之謂重傷。重傷之人，無壽類矣。		
ZZ	神無 <u>惡</u> 乎？不能自勝而強 <u>不</u> 從者，此之謂重傷。重傷之人，無壽類矣！（…）		

Thus we obtain a similar result as in the second example. The received *Zhuang zi* at several instances follows *Lü shi chun qiu* (marked yellow) against *Huai nan zi*. Therefore, it can not derive from the latter. As we also find characters that are shared by *Lü shi chun qiu* and *Huai nan zi* (marked blue) against the received *Zhuang zi* and, on the other hand, at two locations the *Huai nan zi* and the received *Zhuang zi* agree (marked green) against *Lü shi chun qiu*, we again may assume an intermediary version which served as the source of both the received *Zhuang zi* and *Huai nan zi*.

These three examples may suffice to prove that in all likelihood the *Huai nan zi* was not the redaction on which the received *Zhuang zi* is based which, however, does not exclude the possibility that a *Huai nan zi* redaction indeed existed. It simply has not influenced the main line of transmission of the *Zhuang zi* text.

### 3.2 Sima Qian's version

Sima Qian's *Shi ji* is the earliest reference characterizing the *Zhuang zi* – as it was available to him – in slightly more detail. The version he must have had at hand comprised “[...] more than 100.000 words” (其著書十餘萬言).<sup>86</sup> He also lists a few bundle (*pian* 篇) titles, such as “Weilei xu” 畏累虛 (The Wilds of Weilei), “Gengsang (zi)[Chu]” 亢[庚]桑(子) [楚] (Master Gengsang), “Yu fu” 漁父 (The Fisherman), “Dao Zhi” 盜跖 (Robber Zhi), “Qu qie” 胠篋 (Rifling Trunks), of which the first does not occur in the *textus receptus*. Sima's account is interesting for it testifies to the *Zhuang zi* as a text of definite size with an internal structure consisting of defined sub-units called *pian* 篇 or bundles.

<sup>86</sup> *Shi ji* 63: 2143.

The *Shi ji* also preserves an explicit quotation to the effect:<sup>87</sup>

莊子曰：『君子內無飢寒之患，外無劫奪之憂，居上而（不）<sup>88</sup>敬，居下不為害，君子之道也。』

The *Zhuang zi* says: “The gentleman does not suffer when hungry or feeling cold within [his home], and is not sad when being robbed outside [his home]; when living in an upper [position] he [does not] feel honoured, when living in lowliness he does not consider it harmful, [this] is the way of the gentleman.”

These sentences are no longer to be seen within the received *Zhuang zi*. Another passage in the *Shi ji* represents an implicit *Zhuang zi* quotation of a part that is no longer extant in the *textus receptus*. It can be identified since the *Tai ping yu lan* quotes it explicitly:<sup>89</sup>

莊子曰：師曠為晉平公作清角。一奏，有雲從西北起。再奏，大雨大風隨之，裂帷幕，破俎豆，墮廊瓦。平公懼，伏于室內。

The *Zhuang zi* says: “Music Master Kuang performed *Qingjue* for Duke Ping of Jin. When he played [it] the first time, there was a cloud that rose up from the northwest. When he played a second time, it rained heavily and a great wind followed it, split the curtains, broke the sacrificial dishes and platters, and let the tiles of the veranda [roof] fall down. Duke Ping was terrified and hid in the interior of [his] rooms.”

The implicit quotation in *Shi ji* reads:<sup>90</sup>

師曠不得已，援琴而鼓之。一奏之，有白Mittwoch起；再奏之，大風至而雨隨之，飛廊瓦，左右皆奔走。平公恐懼，伏於廊屋之間。晉國大旱赤地三年。

The music Master Kuang couldn't do otherwise and getting hold of [his] lute played it. When he played it the first time, there was a white cloud that rose up from the northwest. When he played it a second time, a great wind arrived and rain followed it and made the tiles of the veranda [roof] fly, [those] left and right all ran away. Duke Ping trembled with fear and hid [in the space] between the veranda and the chambers. [In] the state of Jin a great drought rendered the soil red for three years.<sup>91</sup>

Presenting both passages in a synopsis shows that both share a series of identical phrases and, despite the editorial insertion of the sentence 為晉平公作清角 (“performed *Qingjue* for Duke Ping of Jin”) in the *Tai ping yu lan* and some variant characters, must thus derive from the same source:

<sup>87</sup> *Shi ji* 127: 3219.

<sup>88</sup> Emending 不 according to the structure of the argument.

<sup>89</sup> *Tai ping yu lan* 767: 3a.

<sup>90</sup> *Shi ji* 24: 1236.

<sup>91</sup> Also see the French translation in Chavannes 1967, vol. 3: 290.

## Synopsis 11: TPYL 767 and SJ 24

TPYL	師曠為晉平公作清角。		一奏，	有	雲從西北
SJ	師曠	不得已，援琴	而鼓之。	一奏之，	有白 雲從西北

TPYL	起。再奏，	大雨	大風	隨之，裂帷幕，破俎豆，	墮廊瓦。
SJ	起；再奏之，		大風至而雨	隨之，	飛廊瓦，左右皆奔走。

TPYL	平公	懼，伏于	室	內。
SJ	平公恐	懼，伏於廊	屋之	間。晉國大旱，赤地三年。

As can be expected from quotations, both are abridged. However, as the missing phrases are not identical, both passages in fact complement each other.<sup>92</sup>

Another implicit *Zhuang zi* quotation appears in the *Shi ji*'s *vita* of Zhuang Zhou, confirming the suspicion that Sima Qian has culled his information on Zhuang Zhou from the *Zhuang zi* itself rather than relying on independent sources:<sup>93</sup>

楚威王聞莊周賢，使使厚幣迎之，許以為相。莊周笑謂楚使者曰：「千金，重利；卿相，尊位也。子獨不見郊祭之犧牛乎？養食之數歲，衣以文繡，以入大廟。當是之時，雖欲為孤豚，豈可得乎？」

Nienhauser's translation has:<sup>94</sup>

King Wei of Chu heard that Zhuang Zhou was a worthy man. He sent a messenger with lavish gifts to induce him to come and promised him the position of prime minister. Zhuang Zhou smiled and told Chu's messenger: "A thousand *jin* is great profit, and a ministership an exalted position, but can it be that you have not seen the sacrificial cow used in the suburban sacrifices? After feeding it for several years, it is dressed in figured brocade and sent into the Great Temple. When things have reached this point, though it might wish to become an untended pig, how could it attain this?"

The corresponding *Zhuang zi* pericope is 32.12:<sup>95</sup>

或聘於莊子，莊子應其使曰：「子見夫犧牛乎？衣以文繡，食以芻叔，及其牽而入於大廟，雖欲為孤犢，其可得乎！」

<sup>92</sup> Note that there are additional implicit quotations of this lost pericope in *Han fei zi* 3, *Huai nan zi* 6, *Lun heng* 19, *Lun heng* 63 and *Feng su tong yi* 6. A reconstruction of this passage based on all identified quotations will be offered in the forthcoming critical edition.

<sup>93</sup> *Shi ji* 63: 2145.

<sup>94</sup> Nienhauser et al. 1994: 24.

<sup>95</sup> *Zhuang zi* 32.46.



As translated by Watson:<sup>96</sup>

Someone sent gifts to Zhuang Zi with an invitation to office. Zhuang Zi replied to the messenger in these words: “Have you ever seen a sacrificial ox? They deck him out in embroidery and trimmings, gorge him on grass and beanstalks. But when at last they lead him off into the great ancestral temple, then, although he might wish he could become a lonely calf once more, is it possible?”

The synopsis reveals the matching phrases:

Synopsis 12: SJ 63 and ZZ 32

SJ	楚威王聞莊周賢，使使厚幣	迎	之，	許以為相。	莊周笑謂	楚	使者
ZZ	或	聘於	莊子，		莊子應	其	使
SJ	曰：千金，重利；卿相，尊位也。	子獨不	見郊祭之		犧牛乎？	養食之數歲，	衣以
ZZ	曰：	子	見夫		犧牛乎？		衣以
SJ	文繡，	以入	大廟。當是之時，		雖欲為孤豚，	豈可得乎？	子亟
ZZ	文繡，食以芻菽，及其牽	而入於	大廟，		雖欲為孤犢，	其可得乎？	
SJ	去，無污我。我寧游戲污瀆之中自快，無為有國者所羈，終身不仕，以快吾志焉。						
ZZ							

The *Shi ji* has the more complete text which is partially matched *verbatim* by the corresponding passage of the *textus receptus*. On the other hand, both versions contain phrases that do not occur in the other one. However, there exists an implicit quotation in a work of the third century AD, Ji Kang's 嵇康 (223–269) *Gao shi zhuan* 高士傳 (Biographies of eminent gentlemen).<sup>97</sup> The *Yi wen lei ju* 藝文類聚 (of 604) quotes it as follows:<sup>98</sup>

[嵇康高士傳]又曰。[...]齊宣王又以千金之幣。迎周為相。周曰。子不見郊祭之犧牛乎。衣以文繡。食以芻菽。及其牽入太廟。欲為孤豚。其可得乎。遂終身不仕。

Entering this text into the previous synopsis, we obtain the the following new synopsis:

<sup>96</sup> Watson 1968: 360, Romanisation adapted to *pinyin*.

<sup>97</sup> Ji Kang's *Gao shi zhuan* is no longer extant, however, quite a series of explicit quotations are preserved in various *lei shu*. None of the available reconstructions of the text is satisfactorily done as will be shown by present author in another article (to be published).

<sup>98</sup> *Yi wen lei ju* 36: 640.

## Synopsis 13: SJ 63, JKGSZ and ZZ 32

SJ 楚威 王聞莊周賢，使使 厚 幣迎 之， 許以 為相。 莊 周笑謂  
 JKGSZ 齊宣 王又以千金之 幣迎 周 為相。  
 ZZ 或 聘於 莊子， 莊 子應

SJ 楚使者 曰：「千金，重利；卿相，尊位也。 子獨 不 見郊祭之 犧牛  
 JKGSZ 曰。 子 不 見郊祭之 犧牛  
 ZZ 其使 曰：「 子 見夫 犧牛

SJ 乎？養食之數歲， 衣以文繡， 以 入 大廟。當是之時，  
 JKGSZ 乎。 衣以文繡。 食以芻菽。 及其牽 入 太廟。  
 ZZ 乎？ 衣以文繡， 食以芻菽， 及其牽 而 入於 大廟，

SJ 雖 欲為孤豚，豈可得乎？子亟去，無污我。我寧遊戲污瀆之中自快，無為有國者所羈，  
 JKGSZ 欲為孤豚。其可得乎。  
 ZZ 雖 欲為孤犢，其可得乎！」

SJ 終身不仕，以快吾志焉。」  
 JKGSZ 遂 終身不仕。」  
 ZZ

As several phrases are identical in all three versions (marked yellow), they must belong to the same textual tradition, ultimately going back to the same source text. Ji Kang's version shares with the *Shi ji* phrases (marked blue) that are missing in the received *Zhuang zi*. On the other hand, Ji Kang could not simply have copied the *Shi ji* as his version shares phrases with the received *Zhuang zi* (marked green) that are missing in the *Shi ji*. There are also some correspondences between the *Shi ji* and the received *Zhuang zi* against the *Gao shi zhuan* (marked grey). In other words, the *Shi ji*, again, quotes here implicitly the *Zhuang zi* text, although in the version available to Sima Qian. Ji Kang's version is closer to that of Sima Qian, whereas the received *Zhuang zi* represents the youngest version of the three.<sup>99</sup>

### 3.3 Liu Xiang's redaction

The first important redaction for which clear indications can be found was due to the activities of Liu Xiang 劉向 (79–8 BC) and his son Liu Xin 劉歆 (ob. AD 23) at the Han imperial library. The earliest organization for collecting and copying

<sup>99</sup> Explicit quotations of this *Zhuang zi* pericope also occur in *Yi wen lei ju*, *Wen xuan*, *Bai shi liu tie shi lei ji*, *Tai ping yu lan*, and *Shi lei fu*. The critical edition will have to reconstruct from these versions the most likely “original” *Zhuang zi* pericope, giving due attention to the variations.

books apparently had been set up by Emperor Wu 武帝 (r. 141–87 BC) in or shortly after 124 BC:<sup>100</sup>

迄孝武世，書缺簡脫，禮壞樂崩，聖上喟然而稱曰：朕甚閔焉！於是建藏書之策，置寫書之官。下及諸子傳說，皆充祕府。

Coming to the generation of Filial [Emperor] Wu, [when] books were lacking, bamboo [strips] fallen out, the ritual [texts] spoilt, and the musical [texts] in ruins, the Holy One above, sighing deeply, declared: “We are deeply grieved about it”. Thereupon, he devised a plan for the [proper] storage of the books and to install officials for copying the books. And down to the traditions of the philosophers, all had to fill up private depositories.

A more precise account is provided by Liu Xin:<sup>101</sup>

孝武皇帝敕丞相公孫弘廣開獻書之路。百年之間。書積如丘山。故外則有太常、太史、博士之藏。內則有延閣、廣內、祕室之府。

Filial Emperor Wu ordered the Cauncelor-in-chief Gongsun Hong to open widely the road for presenting books [to the throne]. Within a hundred years books had piled up like mountains. Therefore, outside [the palace] there were the storehouses of the Minister for Public Worship, the Grand Clerks, and the Gentlemen of Wide Learning, and inside were depositories in the long galleries, within the spacious [rooms], and in the Private apartments.

Again in 26 BC the imperial court decided to dispatch an emissary to collect books from all over the empire:<sup>102</sup>

至成帝時，以書頗散亡，使謁者陳農求遺書於天下。

Arriving at Emperor Cheng’s time,<sup>103</sup> as books were vastly scattered and lost, [the Emperor] sent Receptionist Chen Nong to search out lost books throughout the Empire.

Then, a commission was appointed to collate the collected works:<sup>104</sup>

詔光祿大夫劉向校經傳諸子詩賦，步兵校尉任宏校兵書，太史令尹咸校數術，侍醫李柱國校方技。

He commanded Grand Master for Splendid Happiness Lu Xiang to collate the scriptures and [their] commentaries, the [works of the] various philosophers, the *Odes* and the [collections of the] rhapsodies; the Infantry Commandant Ren Hong to collate the military

**100** *Han shu* 30: 1701.

**101** Liu Xin’s *Qi lüe* 七略, ap. *Yi wen lei ju* 12: 17b, collated with the quotations in Ru Shun, comm. *Han shu* 30: 1702, *Bei tang shu chao* 12: 2ab, 101: 1b–2a, 3b, Li Shan, comm. *Wen xuan* 38: 34b, *Chu xue ji* 12: 295, *Tai ping yu lan* 88: 10b, 233: 2b, 619: 1a.

**102** *Han shu* 30: 1701.

**103** 32–7 BC.

**104** *Han shu* 30: 1701.

books, the Grand Astrologer Yin Xian to collate the [books on] mathematics and techniques, and the Physician-in-waiting Li Zhuguo to collate the [books on] technical skills.

This means that, apart from the Confucian classics and the works of poetry, *all* philosophical works collected in the imperial library were subject to Liu Xiang's redaction. It was also his duty to give a detailed report of the activities devoted to each work as soon as the redactional work was accomplished:<sup>105</sup>

每一書已，向輒條其篇目，撮其指意，錄而奏之。

When each single book was finished with, Xiang at once had to itemize the number of its sections, to extract its essential meaning, to list it and to report it [to the Emperor].

Liu Xiang did in fact go much further than that, as he made an entirely new recension (*xin shu* 新書), if necessary arranging the material in new bundles,<sup>106</sup> when a text was presented to him in several different versions. This means that it was Liu Xiang who brought the texts available to him into their “standardized” (*ding* 定) form, in which they were to be stored in the imperial library.

Descriptions of this process are to be found in the accounts of this activity. From the handful or so memorials that have survived until today<sup>107</sup> we know that they are composed according to a fixed pattern: Firstly, the title is given in the form “Title of [Liu Xiang's] new version of [the text] xyz”. Secondly, a list of contents is provided. A report on the redactional activities follows. Then a brief biography of the author is presented, sometimes in part based on the corresponding entry in Sima Qian's 司馬遷 *Shi ji* 史記, together with a discussion of the text's historical background, its authenticity and transmission. Next, the book's value is assessed. The memorial ends with a concluding formula and the date of completion. These reports, called *lu* 錄 (list), were sent to the throne and, in addition, were also attached to the corresponding newly edited book.

An example of a title we find in the memorial on the *Xun zi* 荀子: “New version of Xun Qing, in thirty-two bundles” 荀卿新書三十二篇. The list of contents of the *Lie zi* 列子 report reads:<sup>108</sup>

天瑞第一，黃帝第二，周穆王第三，仲尼第四，湯問第五，力命第六，楊朱第七，說符第八。

<sup>105</sup> *Han shu* 30: 1701.

<sup>106</sup> See *Liu Xiang Yan zi xin shu mu lu*.

<sup>107</sup> They include *Guan zi* 管子, *Yan zi* 晏子, *Lie zi* 列子 (note that while the memorial appears to be authentic, the same does not hold true for the text proper which in its received form is of post-Han origin, although parts of it are considerably older), *Xun Qing* 荀卿 or *Xun zi* 荀子, *Zhan guo ce* 戰國策, and *Shuo yuan* 說苑.

<sup>108</sup> *Lie zi mu lu* 1, in: *Lie zi zhu*.

Heaven's Gift, first [bundle]; Yellow Emperor, second; King Mu of Zhou, third; Confucius, fourth; Tang's Questions, fifth; Endeavour and Destiny, sixth; Yang Zhu, seventh; Explaining Conjunctions, eighth.

For an example of the presentation of the editorial activities, let us have a look at the report on the *Yan zi [chun qiu]* 晏子 (春秋):<sup>109</sup>

護左都水使者光祿大夫臣向言：所校中書晏子十一篇。臣向謹與長社尉臣參校讎，太史書五篇，臣向書一篇，參書十三篇，凡中外書三十篇。為八百三十八章。除復重二十二篇，六百三十八章，定著八篇，二百一十五章。外書無有三十六章，中書無有七十一章。中外皆有以相定。中書以「夭」為「芳」，又為「備」，「先」為「牛」，「章」為「長」。如此類者多。（...）皆已定，以殺青書，可繕寫。

The Commissioner of the Eastern Metropolitan [Area] Conservancy and Grand Master for Splendid Happiness, Your servant [Liu] Xiang, speaking: the books within [the palace] which [I] have collated, were eleven bundles of Master Yan. Your servant [Liu] Xiang has respectfully, together with Your servant, the Commandant of Changshe, [Fu 富]<sup>110</sup> Can, collated five bundles of the book [belonging] to the Grand Astrologer, one bundle of the book [belonging] to Your servant [Liu] Xiang, thirteen bundles of the book [belonging] to [Fu] Can, making a total of thirty bundles of books inside and outside [the palace] [or] 838 sections (章). [I] eliminated twenty-two duplicate bundles [or] 638 sections and made eight bundles [or] 215 sections the standard text. [Of these,] thirty-six sections were lacking in the books outside [the palace] and seventy-one sections were lacking in the books within [the palace]. The [books] inside and outside [the palace] were all made into the standard text by means of mutual [collation]. Books within [the palace] [mistakenly] used the character 夭 instead of 芳 or 備, 先 became 牛, or 章 was made into 長. Of this kind there were many [mistakes]. [...] When all was standardized, [I] wrote [the text] on 'killed green' [bamboo strips], so that it can be exactly copied.

Unfortunately, reports such as this one do not reveal the details of Liu Xiang's procedure. The reader gets the impression that he has put the various duplicate copies of one bundle of text side by side and, collating them, decided – based on which criteria? – which copy is to be preferred, corrected misprints and discarded the other copies.

However, at least in one instance Liu Xiang went much further than that. In fact, he himself arranged the order of the bundles according to his own criteria, e. g. chronologically, emended missing parts and even gave the final book his own title. This is the *Zhan guo ce* 戰國策 (Intrigues of the Warring States), as can be seen in his report on it:<sup>111</sup>

<sup>109</sup> *Yan zi chun qiu zong mu* 1, in: *Yan zi chun qiu jiao zhu*.

<sup>110</sup> Emendation according to *Guan zi shu xu* 2, in: *Guan zi jiao zheng*.

<sup>111</sup> *Zhan guo ce xu* 1a, in *Zhan guo ce jiao zhu*.

護左都水使者光祿大夫臣向言：所校中戰國策書，中書餘卷，錯亂相糅莒。又有國別者八篇，少不足。臣向因國別者，略以時次之，分別不以序者以相補，除復重，得三十三篇。本字多誤脫為半字，以「趙」為「肖」，以「齊」為「立」，如此字者多。中書本號，或曰國策，或曰國事，或曰短長，或曰事語，或曰長書，或曰脩書。臣向以為戰國時，游士輔所用之國，為之策謀，宜為戰國策。其事繼春秋以後，訖(楚)[秦]、漢之起，二百四十五年間之事。皆定，以殺青書，可繕寫。

The Commissioner of the Eastern Metropolitan [Area] Conservancy and Grand Master for Splendid Happiness, Your servant [Liu] Xiang, speaking: [concerning] the book *Zhan guo ce* within [the palace] which [I] have collated, there were in the Secretariat Library a number of fragmented scrolls (卷) which were badly mixed together. Furthermore, there was *another work* in eight bundles (篇), each named after a country, which contained serious deficiencies. Your servant Xiang, following the sequence of countries as given in the one work, *arranged the fragmented [chapters] in rough chronological order*. When I had used those items with no observable order to fill in some of the gaps and after I had discarded duplications, I had a book in thirty-three bundles. Of the original characters many by mistake were deprived of [some elements] and were made [only] half the character, making 趙 into 肖 [or] 齊 into 立. Like these [mistaken] characters there were many. The fragments in the Secretariat Library came from books originally called *Guo ce* 國策, *Guo shi* 國事, *Duan chang* 短長, *Shi yu* 事語, *Chang shu* 長書, and *Xiu shu* 脩書. As Your servant Xiang considered that, during the era of the Warring States, the wandering scholars supporting the states that made use of them proposed schemes on their behalf, it seemed proper [to me] to call [this book] *Zhan guo ce*. Its pericopes connect the affairs of a period of 245 years after the Chunqiu [era] until the rise of the Qin and Han [dynasties]. When all was standardized, [I] wrote [the text] on 'killed green' [bamboo strips], so that it can be exactly copied.<sup>112</sup>

There is also evidence that Liu Xiang created entirely new bundles whenever this seemed suitable, as the following extract from his report on the *Yan zi* 晏子 shows:<sup>113</sup>

又有復重文辭頗異。不敢遺失，復列以為一篇。又有頗不合經術，似非晏子言。疑後世辯士所為者。故亦不敢失，復以為一篇。凡八篇。其(六)(八)篇可常置旁御觀。謹弟錄。臣向味死上。

There were also duplicate [parts whose] wording differed considerably. [As] I did not dare discarding [them], I arranged them again into one bundle. In addition, there were words [that] did absolutely not correspond with the classics<sup>114</sup> and the technical [books], and seemed not to be Yanzi's. I suspected that they are what later disputers have made. Therefore, I also did not dare discarding [them] and again kept them and made one bundle. All in all [there were] eight bundles. These eight bundles can permanently be

<sup>112</sup> Italics added, for a slightly different translation see Crump 1970: 1.

<sup>113</sup> *Yan zi chun qiu zong mu* 2, in: *Yan zi chun qiu jiao zhu*.

<sup>114</sup> That the classics must be meant is clear from the similar phrase in Liu Xiang's reports on his *Yan zi* edition: 皆合六經之義 and on his *Lie zi*: 合於六經.

put aside for the emperor's inspection. I have respectfully drawn up this list of contents, [which] Your servant [Liu] Xiang at the risk of his life submits [to Your Majesty].

This seems to indicate that Liu Xiang, besides merely correcting erroneous characters, extracted parts of the text (of differing wording, of doubtful contents) and rearranged them into new bundles giving the text as a whole its new standardized form. We must, therefore, be prepared for the possibility that Liu Xiang has considerably altered many if not all the texts at his disposal in the imperial library which truly justifies the titles he has given them: *xy* 新書 (New book of *xy*)! To state it clearly, at least all philosophical texts (and most likely all poetic texts as well) listed in the *Han shu* bibliography that were treasured in the Han imperial library have been edited to some extent by Liu Xiang.

After Liu Xiang's death, his son, Liu Xin, continued his father's practice. Later, these reports were collected and edited into a book called *Bie lu* 別錄 (Separate Lists) which still existed in Tang times, but, unfortunately, is now lost. The fact that this *Bie lu* survived into the Tang lets us reject the hypothesis, formulated by Qian Mu 錢穆, that Liu Xiang's *Lie zi lu* 列子錄 must be a fake,<sup>115</sup> made by the compiler of the fourth century AD version of the *Lie zi*.

For our purposes it is important that in Liu Xiang's reports after the title of the work in question a list of contents was provided, followed by the report on the redactional activities after which a brief or "minimal" biography of the author of the text was presented. In some instances, Liu Xiang heavily relied on the biography to be found in the *Shi ji*. The minimal biography of, e. g., *Lie zi* reads:<sup>116</sup>

列子者，鄭人也，與鄭繆公同時，蓋有道者也。其學本於黃帝老子，號曰道家。道家者，秉要執本，清虛無為，及其治身接物，務崇不競。

Master Lie was a person from Zheng and a contemporary of Duke Miu of Zheng and was one who covered (?) those who had the *dao*. His learning based on Huang di and Lao zi, [which] is called "the Daoist school" (*dao jia*). As for the Daoist school, it grasps the important and holds the original, [it keeps] clear emptiness and no active involvement, as well as controls the body and is of help to others, devotes attention to the venerable and does not quarrel.

If the hypothesis is correct that all important philosophical pre-Han and early Han texts then available were edited by Liu Xiang and that they were accompanied by his reports, then we expect that the *Zhuang zi* has also gone through Liu Xiang's hand and was given a *Zhuang zi lu* 莊子錄.

<sup>115</sup> *Yenching Journal of Chinese Studies*, No. 7, June 1930: 1215–1216.

<sup>116</sup> *Lie zi mu lu* 2, in: *Lie zi zhu*.

Fragments of a *Zhuang zi lu* 莊子錄 as contained within the *Bie lu* do survive indeed. One quotation is to be seen in Sima Zhen's 司馬貞 (early eighth century AD) *Suo yin* 索隱 commentary to the *Shi ji* biography of Zhuang Zhou. Commenting the *Shi ji* sentence 莊子者蒙人也 (“Master Zhuang was a person from Meng”), the *Suo yin* quotes (...) 劉向別錄云：宋之蒙人也, (“[...] Liu Xiang's *Bie lu* says: [Master Zhuang] was a person from Meng of [the state of] Song”).<sup>117</sup> This *Suo yin* quotation of the *Zhuang zi lu* must have been taken from its “minimal” biography section.

It is noteworthy in this context that in some of his extant *shu lu* Liu Xiang explicitly refers to *Zhuang zi* or Zhuang Zhou which corroborates his acquaintance with the text. Thus we read in his memorial on *Lie zi* which he had submitted October 7, 14 BC (永始三年八月壬寅上).<sup>118</sup>

且多寓言與莊周相類，故太史公司馬遷不為列傳。

Moreover, his many imputed words are of the same category than Zhuang Zhou's. Therefore, the Grand Historiographer Sima Qian did not compose a [Master] Lie biography.

And the memorial on the *Xun zi* has: “He was contemptuous of scholars arguing over minutiae, such as people like Zhuang Zhou”<sup>119</sup> (鄙儒小拘，如莊周等). However, these phrases within the assessment part of his memorial do not represent Liu Xiang's own writing but are *verbatim* copied from Sima Qian's Xun Qing biography.<sup>120</sup>

Unfortunately, the *Zhuang zi lu* as a whole is lost, we therefore do not know how the textual material looked like that Liu Xiang has used for his standardized version. In particular, we do not know whether he was responsible for the division of the text into “inner bundles”, “outer bundles” and “miscellaneous bundles”, although this is quite likely. Until a *Zhuang zi* manuscript eventually comes to the light, excavated from a pre-Han or early Han tomb, we cannot have any idea about the original structure(s) the entire text(s) had before it (they) went through Liu Xiang's filter, as it were.

Apart from his bibliographic duties, Liu Xiang also produced works of his own such as the *Xin xu* 新序 (presented to the throne in 25 BC or 24 BC), a collection of moralistic anecdotes and historical tales, and the *Shuo yuan* 說苑 (presented to the throne in 17 BC), a compilation of moral tales and political admonitions, both mainly consisting of paraphrases and *verbatim* extracts from

117 *Shi ji* 63: 2144.

118 *Lie zi mu lu* 2, in: *Lie zi zhu*.

119 Nienhauser et al. 1994: 184.

120 *Shi ji* 74: 2348.



texts he had dealt with while producing their standardized versions. This makes these two sources so important. If implicit *Zhuang zi* quotation could be identified in them, they would represent the state of the text as it was in the hands of Liu Xiang and before it went through Guo Xiang's.

Emperor Chengdi 稱帝 (r. 33–7 BC), during whose reign the bibliographic enterprise took place, gave a manuscript of the *Zhuang zi* – most likely a copy of Liu Xiang's redaction – as a present to Ban You 班斡 (ob. 2 BC), one of the scholars active in this collecting, collating and classifying endeavour and collaborator of Liu Xiang,<sup>121</sup> who in turn bequeathed it to his son Ban Si 班嗣. By his time, the book must have been quite rare already. Huan Tan 桓譚 (c. 43 BC – AD 28), bibliophile and himself owner of a respectable library, therefore asked Ban Si to lend him the book, but Ban Si refused it.<sup>122</sup>

Ban Gu 班固 (AD 32–92) who in his *Han shu* presents the catalogue of the imperial library of the Former Han together with the comments on all bibliographic sections – which were based on Liu Xin's *Qi lue* 七略 – lists a *Zhuang zi* in fifty-two bundles (篇 *pian*).<sup>123</sup> This must have been Liu Xiang's standardized version. It is worth noting that Ban Gu also wrote a *Zhuang zi* commentary, four fragments of which are still extant in Lu Deming's *Jing dian shi wen*.<sup>124</sup> Here we find the interesting hint that at least the sentence (if not the whole pericope that follows) 夫道未始有封 (“the Way has never known boundaries...”<sup>125</sup>), which in the received version is to be found in the second chapter and thus in the *nei pian* part, according to Ban Gu belonged to the *wai pian* part: 班固說在外篇.<sup>126</sup> This attests the existence of a division of the *Zhuang zi* into (at least) a *nei pian* and a *wai pian* part in Ban Gu's time. If he who must have had access to the imperial library was working with Liu Xiang's version, then this version must have consisted of (at least) two parts and, as can be assumed from Liu Xiang's extant memorials, its *pian* may have been further subdivided into *zhang* (章) or sections.

Gao You 高誘 (c. 168–212) towards the end of the Han dynasty also had a *Zhuang zi* in 52 *pian* at hand, as he says in his commentary to the *Lü shi chun qiu*: “Master Zhuang [...] wrote a book in 52 bundles and named it *Zhuang zi*” (莊子 (...) 著書五十二篇, 名之曰莊子).<sup>127</sup>

121 *Han shu* 100A: 4203.

122 *Han shu* 100A: 4205.

123 *Han shu* 30: 1730.

124 *Jing dian shi wen* 26: 6a; 26: 8b; 26: 9a; 26: 10b.

125 Watson 1968: 43.

126 *Jing dian shi wen* 26: 8b.

127 *Lü shi chun qiu* 14: 155.

### 3.4 After the Han dynasty

The collapse of the Han dynasty caused a widespread crisis not only among Chinese intellectuals. Confucianism, the philosophical tradition of the ruling Han élite, was discredited. Many well-educated persons withdrew from official life as they were no longer interested in politics and administration. Accordingly, the Western Jin (265–316) period and the subsequent centuries saw a remarkable increase of intellectual interest in the *Zhuang zi*, a text which emphasized the individual mind and its development and apparently rejected involvement with government. As it is stated in Xiang Xiu's (ca. 221–ca.300) *vita* in the *Jin shu* 晉書:<sup>128</sup>

惠帝之世 (... ) 儒墨之跡見鄙，道家之言遂盛焉。

During the generation of Emperor Hui (290–306), [...] the traces of Confucianism and Mohism faced disdain and the words of the Daoist school thereupon flourished.

A reflection of the *Zhuang zi* renaissance can be seen in Liu Yiqing's 劉義慶 (403–444) statement:<sup>129</sup>

初，注莊子者數十家，莫能究其旨要。

Previously none of the several tens of commentators on the *Zhuang zi* had ever been able to get the full essence of its ideas.<sup>130</sup>

This renewed interest in *Zhuang zi* obviously led to an “outburst” of commentaries on this work. Lu Deming's *Jing dian shi wen* in fact lists nine commentaries together with their respective editions prominent during the Western Jin.

One written by Sima Biao (司馬彪注), to be dated after 265, according to Lu Deming in ca. 625 comprised twenty scrolls (*juan* 卷) with fifty-two bundles (*pian* 篇).<sup>131</sup> It is worth noting that Sima Biao, as Director of the Palace Library (*bi shu jian* 祕書監) of the Jin, must have had access to the books which the Jin imperial library had inherited from the Han imperial library. His recension most likely was based on Liu Xiang's. Sima's text was, again according to Lu Deming, arranged in seven “inner” (*nei* 內), twenty-eight “outer” (*wai* 外), fourteen “mixed” (*za* 雜) bundles and three “interpretative essays” (*jie shuo* 解說).<sup>132</sup> It may well be that these interpretative essays included the now lost “Huai nan

<sup>128</sup> *Jin shu* 49: 1374.

<sup>129</sup> *Shi shuo xin yu* 4: 51.

<sup>130</sup> Mather 2002: 105.

<sup>131</sup> *Jing dian shi wen* 1: 34a.

<sup>132</sup> *Jing dian shi wen* 1: 34a.

wang *Zhuang zi lue yao*” 淮南王莊子略要 which is attributed to Liu An, as Li Shan in his commentary to the *Wen xuan* quotes it three times together with a comment by Sima Biao, whereas Sima Biao is not known for having written any commentary to the *Huai nan zi*.<sup>133</sup> The bibliographical chapters of the *Sui shu* 隨書 (completed 656) whose composition had been ordered in 641 lists a *Zhuang zi* in sixteen scrolls (*juan* 卷) with Sima Biao’s commentary (莊子十六卷, 司馬彪注) and an edition of apparently the same but originally in twenty-one scrolls, now missing (本二十一卷今闕).<sup>134</sup> The next extant bibliography of any imperial library is the *Jiu Tang shu* “*jingji zhi*” 舊唐書經籍志 of 945. Its bibliographical entries represent the inventory of the Tang imperial library of ca. 721. Here we find the entry “[*Zhuang zi*] also in twenty-one scrolls, commentary by Sima Biao” (又二十一卷。司馬彪注).<sup>135</sup> In other words, Sima Biao’s commentary attached to the Han recension was available until the eighth century. However, after the Tang it was lost.

Lu Deming also lists a *Zhuang zi* in eighteen scrolls with 52 bundles whose commentary was composed by a Mister Meng’s 孟氏, otherwise unknown (孟氏注十八卷五十二篇, 不詳何人).<sup>136</sup> This was already lost during the Sui dynasty, as the *Sui shu* has a “*Zhuang zi*, eighteen scrolls, commentary by Mister Meng, one scroll of memorial (Liu Xiang’s memorial?), lost” (莊子十八卷, 孟氏注, 錄一卷。亡。)<sup>137</sup> Although Lu has not seen Meng’s recension – neither does he provide any additional information nor does he quote his commentary in his own *Zhuang zi yin yi* 莊子音義 –, he assumes that both Sima Biao and Mister Meng had the same recension at hand:<sup>138</sup>

漢書藝文志莊子五十二篇，即司馬彪孟氏所注是也。

The *Zhuang zi* in fifty-two bundles of the *Han shu* “*yi wen zhi*”, this is namely what Sima Biao and Mister Meng had commented.

It is Sima’s commentary that Lu Deming quotes most of all, nevertheless it may be worth noting that a series of explicit quotations of Sima’s commentary can be found in various *lei shu* that are not to be found in Lu’s *Zhuang zi yin yi*.

Also mentioned by Lu is Cui Zhuan’s 崔譔 (third to fourth century) *Zhuang zi* text with commentary in ten scrolls and twenty-seven bundles. Lu adds that it contained “seven inner bundles” and “twenty outer bundles” (內篇七, 外篇二

133 Roth 1992: 32–33.

134 *Sui shu* 34: 1001.

135 *Jiu Tang shu* 47: 2028.

136 *Jing dian shi wen* 1: 34a.

137 *Sui shu* 34: 1001.

138 *Jing dian shi wen* 1: 33b.

十). The *Sui shu* says that during the Liang dynasty (502–557) there existed a *Zhuang zi* in ten scrolls, commented by Cui Zhuan but now lost.<sup>139</sup> The *Jiu Tang shu* bibliography, on the other hand, lists a *Zhuang zi* in ten scrolls with Cui Zhuan's commentary.<sup>140</sup>

Lu then refers to various *Zhuang zi* editions commented by Xiang Xiu 向秀 (227–272), one in twenty scrolls and twenty-six bundles, another one in twenty-seven bundles, and one in twenty-eight bundles but lacking the “mixed bundles”, yet having three scrolls of phonetic glosses (一作二十八篇亦無雜篇為音三卷).<sup>141</sup> The *Sui shu* bibliography also lists a twenty scroll *Zhuang zi* with Xiang Xiu's commentary but has it as “now missing” (今闕).<sup>142</sup> The *Jiu Tang shu* has the entry “Also [*Zhuang zi*] in twenty scrolls. Commentary of Xiang Xiu.”<sup>143</sup>

Li Yi 李頤 (third to fourth century), according to Lu Deming, had composed “collected explanations” (集解) in thirty scrolls and thirty bundles of which the *Sui shu* says that “the Liang had it in thirty scrolls”.<sup>144</sup> The *Tang shu* lists it as in twenty scrolls.<sup>145</sup> Lu adds the information that [in his time] there was also another edition of this work in thirty-five bundles and one scroll of phonetic glosses (一作三十五篇為音一卷).<sup>146</sup>

Other commentaries mentioned by Lu are Wang Shuzhi's 王叔之 (fourth century) in three scrolls, which the *Sui shu* lists as lost,<sup>147</sup> Li Gui's 李軌 (fourth century) phonetic glosses in one scroll and Xu Miao's 許邈 phonetic glosses in three scrolls. None of these three commentaries is to be found in the Tang bibliography.

The most influential commentary, however, was that of Guo Xiang 郭象 (ob. 312), compiled in thirty-three scrolls and thirty-three bundles.<sup>148</sup> Even those commentaries that survived into the Tang period were gradually replaced by Guo Xiang's to which we will have to turn shortly.

Note that Lu Deming, although he does not list them in his *Zhuang zi yin yi*, also quotes additional commentaries such as one written by Liang Emperor Jian wen 梁簡文帝 (r. 549–551) which the *Sui shu* has as of “ten scrolls. Originally

139 *Sui shu* 34: 1001.

140 *Jiu Tang shu* 47: 2028.

141 *Jing dian shi wen* 1: 34a.

142 *Sui shu* 34: 1001.

143 *Jiu Tang shu* 47: 2028.

144 *Sui shu* 34: 1001.

145 *Jiu Tang shu* 47: 2028.

146 *Jing dian shi wen* 1: 34a.

147 *Sui shu* 34: 1002.

148 *Jing dian shi wen* 1: 34a.

twenty scrolls, now missing”.<sup>149</sup> The *Tang shu* has it in thirty scrolls.<sup>150</sup> However, Lu quotes Emperor Jianwen’s notes only in the first seven and the fourteenth chapters (of the received edition). This may indicate that either Lu did not have Emperor Jianwen’s complete version at hand or that Jian wen di himself did not have a complete version of the then available *Zhuang zi* or that he was only interested in a restricted number of its chapters. Another commentary quoted by Lu but not listed in the preface of his *Jing dian shi wen* is that of the famous Buddhist monk Zhi Dun 支遁 (314–366) who had interpreted the first chapter of the received *Zhuang zi*, “Free and easy wandering” (逍遙遊). This was called *Zhi shi xiao yao lun* 支氏逍遙論 (Mister Zhi’s essay on free and easy [wandering]). An extract thereof is quoted in Liu Jun’s (462–521) 劉峻 commentary to Liu Yiqing’s *Shi shuo xin yu* 世說新語 (A new account of tales of the world).<sup>151</sup>

The sheer number of *Zhuang zi* commentaries that appeared between the Later Han and the Sui dynasties and the fact that even Buddhists felt obliged to deal with this text reflects the great interest this work generated within this period. As a further, although anecdotal, piece of evidence a pericope may serve that is to be found in the *Shi shuo xin yu*:<sup>152</sup>

支道林、許、謝盛德，共集王家。謝顧謂諸人：「今日可謂彥會。時既不可留，此集固亦難常。當共言詠，以寫其懷。」許便問主人：「有莊子不？」正得漁父一篇。謝看題，便各使四坐通。支道林先通，作七百許語，敘致精麗，才藻奇拔，眾咸稱善。於是四坐各言懷。畢。謝問曰：「卿等盡不？」皆曰：「今日之言，少不自竭。」謝後羸難，因自敘其意，作萬餘語，才峰秀逸。既自難干，加意氣擬託，蕭然自得，四坐莫不厭心。支謂謝曰：「君一往奔詣，故復自佳耳。」

This reads in Mather’s translation as follows:<sup>153</sup>

Zhi Daolin (= Dun), Xu [Xun], Xie [An] and others of outstanding virtue were gathered together at the home of Wang [Meng]. Xie, looking all around, said to everyone: “Today’s is what might be called a distinguished assembly. Since time may not be made to stand still, and this assembly as well, no doubt, would be hard to prolong, we should all speak or intone [poems], to express our feelings.” Xu then asked the host: “Have you a copy of the *Zhuang zi*?” It so happened that he had the one bundle “The old fisherman”. Xie looked at the title and then asked everyone present to make an exposition of it. Zhi Dun was the first to do so, using seven hundred or more words. The ideas of his exposition were intricate and graceful, the style of his eloquence wonderful and unique. The whole company voiced his praises. After him each of those present told what was in his mind. When they had

149 *Sui shu* 34: 1002.

150 *Jiu Tang shu* 47: 2029.

151 *Shi shuo xin yu* 4: 55; translated Mather 2002: 115.

152 *Shi shuo xin yu* 4: 60.

153 Mather 2002: 127–128, mildly modified.

finished, Xie asked them: “Have you gentlemen fully expressed yourselves?” They all said: “In what we’ve said today, few of us have not expressed ourselves fully.” Xie then raised a few difficulties, and on the basis of these set forth his own ideas, making more than ten thousand words. The peak of his eloquence was far and away superior to any of the others. Not only was he unquestionable beyond comparison, but in addition he put his mind and “energy” into it, forthright and self-assured, there was no one present who was not satisfied in his mind. Zhi [Dun] said to Xie: “From beginning to end you rushed straight on; without any doubt you were the best.”

This not only allows to get a glimpse of the intellectual games played at parties of upper class men during the time of disunion but it also shows that texts were not necessarily available in their entirety, it was well possible that only a single “chapter” or a few “chapters” of a work were available within a household.

### 3.5 Guo Xiang

The second dramatic redaction the *Zhuang zi* underwent during its transmission after that of Liu Xiang was Guo Xiang’s. Guo wrote a report on his activity which is still extant, attached to the “Tian xia” chapter in the *Zhuang zi* manuscript (dating from the Muromachi period, 1392–1568, but being based on a very old edition, in all probability from early Tang)<sup>154</sup> preserved in the Kôzanji 高山寺 (Temple) in Kyoto, Japan. It is partially duplicated in Lu Deming’s *Jing dian shi wen* “xu lu”.<sup>155</sup> As it is important for our purposes, the relevant parts may be presented:<sup>156</sup>

(... ) 然莊子閎才命世，誠多英文偉詞，正言若反，故一曲之士不能暢其弘旨，而妄竄奇說，若《闕亦（奕）》、《意循（俯）》之首，《尾（危）言》、《游易（覺）》、《子胥》之篇，凡諸巧雜，若此之數，十分有三，或牽之令近，或遷之令誕，或似《山海經》，或似（占）夢書，或出《淮南》，或辯形名，（...），龍蛇並御，且辭氣鄙背，竟無深澳，而徒誰知，似因（困）後蒙，令沈滯失乎（平）流，豈所求莊子之意哉？故皆略而不存。令（今）唯哉（裁）取其長，達致全平大體者焉為三十三篇者。（...）

[...] Master Zhuang’s vast talent was known throughout the world; he was truly a man of outstanding ability and mighty words. But because he expressed truths in paradoxes, the twisted scholars who followed him were not able to explicate his expansive meaning but perversely interpolated wrong ideas – [for example,] at the beginning of the “E yi” 闕奕 and “Yi xiu” 意脩 [bundles], and in the “Zhi yan” 卮言, “You fu” 遊覺; and “Zi xu” 子胥 bundles. Such ingenious admixtures constitute some thirty percent of the whole: some of these lead us close to the text’s original meaning, while others distract us with absurdities;

154 Roth 1993: 62.

155 *Jing dian shi wen* 1: 33b.

156 Teraoka 1966: 216.

some resemble the *Classic of hills and seas* (*Shan hai jing* 山海經) while others resemble books of dream interpretation; some come from the *Huai nan* [zi], while others debate form and name (*xing ming* 形名). [...] The style of these admixtures is vulgar and unseemly, and has neither profundity nor subtlety. Moreover, because of the troublesome obscurities [this writing introduces], it is difficult to know [the real text]; the submerged obstacles this writing creates block the current of ideas. How, then, can one seek out Master Zhuang's meaning? For while there is a sketch [of Zhuang zi's concepts], his ideas are not [completely] preserved. Thus, I have endeavoured to take from this writing only what is far-penetrating and serves to preserve the main body [of Master Zhuang's thought]. The result is a work of thirty-three bundles [...].<sup>157</sup>

Relying on his own judgement Guo Xiang thus reduced the text by roughly a third, from “more than 100,000 words”, according to Sima Qian's *Shi ji*, to 63,000 odd words in the received text. On the other hand, he must have reorganized at least parts of the text, since some passages of the *Zhuang zi* which early sources located in the “outer bundles” are now to be found in the “inner bundles” and *vice versa*; some bundles he separated, and originally separated bundles he united.<sup>158</sup>

This Guo Xiang recension has been transmitted continuously until the present time, being the sole recension available since the Tang period.<sup>159</sup> Even the Buddhist *Zhuang zi* mss. found in the Dunhuang caves and now treasured in the British Library and the French Bibliothèque Nationale are based on Guo Xiang's version. Nevertheless, in the course of its transmission even the Guo Xiang commentary suffered losses.<sup>160</sup>

In view of *Zhuang zi*'s popularity after the Han dynasty it is to be expected that a systematic examination of the Chinese literature up to Tang times and including the Buddhist texts composed in China proper will lead to the discovery of lost parts of the *Zhuang zi*.<sup>161</sup>

---

**157** Rand 1983:12–13, slightly modified and italics added. For a different translation cf. Knaut 1982.

**158** Wang 1994, vol. 3: 1434–1437, and Roth, 1993: 58. Knaut 1982: 72.

**159** Roth 1993: 58.

**160** Whereas the sentence 社稷存焉爾 in the received version of *Zhuang zi* (20.59) has Guo Xiang's commentary 況之至人則玄同天下，故天下樂推而不厭，相與社而稷之，斯無受人益之所以為難也 (Guo 1993, vol. 3: 693), the version quoted in Li Shan's comment to *Wen xuan* 28: 519a is considerably longer 至人則玄同天下，故天下樂推而不厭，相與社而稷之，斯無受人益之所以為難矣。然文雖出彼，而意微殊，彼以榮辱同途，故安之甚易此以吉凶異轍，故辭之實難。

**161** First results obtained by an examination of Ge Hong's 葛洪 (283–343) works were presented by this author in a paper entitled “Critical edition of *Zhuang zi* – in search of the lost text” at the EACS Conference in Paris (Bumbacher 2012). A paper covering a larger sample of source texts is under preparation.

## 4 Preliminary reconstructions

### 4.1 Identifying lost pericopes

The first step in the reconstruction process of lost *Zhuang zi* text consists in systematically looking for explicit quotations in texts of pre-Han up to Tang times of the form 莊子曰 (or 莊周曰).<sup>162</sup>

#### 4.1.1 Sea gulls

This yields, e. g., the following passage to be found in Liu Jun's commentary to Liu Yiqing's *Shi shuo xin yu*:<sup>163</sup>

莊子曰：海上之人好鷗者，每旦之海上，從鷗游，鷗之至者數百而不止。其父曰：吾聞鷗鳥從汝游，取來玩之。明日之海上，鷗舞而不下。

Mather's translation goes like this:

[*Zhuang zi* says:] "A man who lived by the sea was fond of sea gulls, and went every morning to the seashore where he accompanied the gulls in their play. The gulls that came to him numbered in the hundreds. The man's father said: 'I hear the gulls accompany you in your play. Bring one home so I can play with it, too.' The next day when the man went to the seashore, the gulls hovered above him, but would not come down."

Independently from the *Shi shuo xin yu*, these sentences are also quoted as coming from the *Zhuang zi* in Li Shan's commentary to the Tang literary anthology *Wen xuan*:<sup>164</sup>

(莊子)又曰：海上有人好鷗鳥者，旦而之海上，從鷗鳥游，鷗鳥至者百數。其父曰：吾聞鷗從汝遊，試取來，吾從玩之，曰：諾。明旦之海上，鷗鳥舞而不下。

Most interestingly, the very same passage is already to be found as an implicit quotation in the *Lü shi chun qiu*:<sup>165</sup>

(...) 海上之人有好蜻者，每居海上，從蜻游，蜻之至者，百數而不止，前後左右盡蜻也，終日玩之而不去。其父告之曰：聞蜻皆從女居，取而來，吾將玩之。明日之海上，而蜻無至者矣。

<sup>162</sup> An early collection of *Zhuang zi* fragments was compiled by Wang Yinglin (1223–1296) in his *Kun xue ji wen* 困學紀聞 which presents some 38 examples of which 27 have been translated by Knaut 1982: 59–69. The most recent collection is Wang 1994, vol. 3: 1386–1412.

<sup>163</sup> *Shi shuo xin yu* 2: 26. Also see Wang 1994, vol. 3: 1387.

<sup>164</sup> *Wen xuan* 31: 28a.

<sup>165</sup> *Lü shi chun qiu* 18: 221.



It can also be seen as an implicit quotation in the *Lie zi*:<sup>166</sup>

海上之人有好漚鳥者，每旦之海上，從漚鳥游，漚鳥之至者百住而不止。其父曰，吾聞漚鳥皆從汝游，汝取來，吾玩之。明日之海上，漚鳥舞而不下也。（…）

The synopsis of these representations of a lost *Zhuang zi* pericope reads as follows:

Synopsis 14: LSCQ 18, Lie zi 2, SSXY 2, and comm. WX 31

LSCQ	(…)	海上之人	有	好蜻	者，每	居海上，從蜻	游，
LZ		海上之人	有	好漚鳥	者，每旦	之海上，從漚鳥	游，
SSXY	莊子曰：	海上之人		好鷗	者，每旦	之海上，從鷗	游，
WX	〔善曰莊子〕又曰：	海上	有人	好鷗鳥	者，旦而	之海上，從鷗鳥	游，

LSCQ	蜻	之	至者，	百數	而不止，	前後左右盡蜻也，	終日玩之而不去。	其父告之
LZ	漚鳥	之	至者	百住	而不止。			其父
SSXY	鷗	之	至者，	數百	而不止。			其父
WX	鷗鳥		至者	百數。				其父

LSCQ	曰：	聞蜻	皆	從女居，	取而	來，吾將	玩之。	明日之海上，
LZ	曰，吾	聞漚鳥	皆	從汝游，汝	取	來，吾	玩之。	明日之海上，
SSXY	曰：吾	聞鷗鳥		從汝游，	取	來，	玩之。	明日之海上，
WX	曰：吾	聞鷗		從汝遊，試	取	來，吾從	玩之，曰：諾。	明旦之海上，

LSCQ	而	蜻	無至者矣。					
LZ		漚鳥	舞		而不下也。	(…)		
SSXY		鷗	舞		而不下。			
WX		鷗鳥	舞		而不下。			

As can be seen in this synopsis, all versions *verbatim* agree to such an extent that they must belong to the same textual tradition, ultimately going back to the same source text. However, the versions of both the *Shi shuo xin yu* and the *Wen xuan* commentaries as well as the *Lie zi* are abridged compared with the *Lü shi chun qiu*, as the *Lü shi chun qiu*'s two sentences 前後左右盡蜻也，終日玩之而不去 are missing. Also there are some differences between them and the *Lü shi chun qiu*, as all three read 每旦之海上 (LZ, SSXY) or 旦而之海上 (WX) against 每居海上 (LSCQ), and all three have 從汝游 (LZ, SSXY) or 從汝遊 (WX) against 從女居 (LSCQ) and all three preserve the last sentence as 舞而不下 whereas the LSCQ reads 無至者矣. Without going into more details,<sup>167</sup> it should be clear that between the Qin dynasty (composition of the *Lü shi chun qiu*) and the fourth century AD (*Lie zi*) the text had been subject to modifications.

<sup>166</sup> *Lie zi zhu* 2: 21.

<sup>167</sup> The forthcoming critical edition of the *Zhuang zi* will discuss them.

#### 4.1.2 Yin Ru

Each explicitly quoted *Zhuang zi* sentence found in a *lei shu* has to be checked against the received *Zhuang zi*. If it cannot be located there, it may be regarded as a candidate for a lost part of the *Zhuang zi*. If, by chance, this quotation is accompanied by the quotation of a part of Sima Biao's commentary, then it can be taken for granted that both belong to the pre-Guo Xiang version of the *Zhuang zi*. The example of Yin Ru who studied charioteering has already been introduced above (1.1.3). Let us now look at it in more detail. In Li Shan's commentary to the *Wen xuan* we find twice virtually the same explicit *Zhuang zi* quotation, both followed by the identical explicit quotations of Sima Biao's commentary. The first reads:<sup>168</sup>

〔善曰〕莊子曰：尹需學御，三年而所得，夜受秋駕於其師。明日往朝其師，其師望而謂之曰：吾非獨愛道也，恐子之未可與也。今將教子以秋駕。司馬彪曰：秋駕，法駕也。

And the second, abridged if compared with the first one:<sup>169</sup>

〔善曰〕莊子曰：尹儒學御，三年而無所得，夜夢受秋駕，明日往朝師，師曰：今將教子以秋駕。司馬彪曰：秋駕，法駕也。

Now the very same passage can be found as implicit quotations both in the *Lü shi chun qiu* and in the *Huai nan zi*. The *Lü shi chun qiu* version goes:<sup>170</sup>

〔...〕尹儒學御，三年而不得焉，苦痛之，夜夢受秋駕於其師。明日往朝其師，望而謂之曰：吾非愛道也，恐子之未可與也。今日將教子以秋駕。尹儒反走，北面再拜曰：今昔臣夢受之。〔...〕

Knoblock and Riegel translated this passage as follows:<sup>171</sup>

Yin Ru studied charioteering for three years without mastering it, a fact that so gratefully saddened him that one night he dreamt of learning the art of 'autumn driving' from his teacher. The next day he went to pay his respects to his teacher, who looked directly at him and said: "It is not that I have been sparing about imparting the right Dao, but that I feared you were not capable of being taught. Now, however, I will teach you the art of 'autumn driving'." Yin Ru turned to leave but assumed the humble position of facing north and bowed twice to his teacher and said: "I dreamed last night of having learned it."

*Huai nan zi*'s version reads:<sup>172</sup>

<sup>168</sup> Comm. *Wen xuan* 6: 132b. Also see *Kun xue ji wen* 32b which does not reveal its source and Wang 1994, vol. 3: 1392.

<sup>169</sup> Comm. *Wen xuan* 46: 17a.

<sup>170</sup> *Lü shi chun qiu* 24: 315.

<sup>171</sup> Knoblock/Riegel 2000: 619.

<sup>172</sup> *Huai nan zi* 12: 207.

尹需學禦，三年而無得焉。私自苦痛，常寢想之。中夜，夢受秋駕于師。明日往朝，師望之，謂之曰：吾非愛道於子也，恐子不可予也。今日教子以秋駕。尹需反走，北面再拜曰：臣有天幸，今夕固夢受之。

which was translated by Sarah A. Queen in the following way:<sup>173</sup>

Yin Ru was studying charioteering, but three years passed and he had not yet mastered it. He was so troubled and grieved by this that when he slept, his thoughts often drifted to charioteering. Once in the middle of the night he dreamed that he received instruction in “Autumn Driving” from his teacher. The next morning he visited his teacher, who looked at him and said: „It is not that I have been withholding my Way from you; it is just that I feared you were not capable of receiving my instruction. Today I will instruct you in “Autumn Driving”. Yin Ru tuned around to take leave; facing north he bowed twice and replied: “I have enjoyed Heaven’s good fortune. This past evening I already received such instruction in my dreams!”

Again, it may be useful to present the four quotations in a synopsis:

Synopsis 15: LSCQ 24, HNZ 12, *comm.* WX 6, *comm.* WX 46

LSCQ	尹儒學御，	三年而不	得焉，	苦痛之，
HNZ 12	尹需學禦，	三年而無	得焉。私自	苦痛，常寢想之。中
WX 6	（善曰）莊子曰：	尹需學御，	三年而無	所得，
WX 46	（善曰）莊子曰：	尹儒學御，	三年而無	所得，

LSCQ	夜夢	受秋駕於其	師。	明日往朝其	師，	望而	謂之	曰：「吾非
HNZ 12	夜夢	受秋駕于	師。	明日往朝，	師，	望之，	謂之	曰：“吾非
WX 6	夜	受秋駕於其	師。	明日往朝其	師，其師	望而	謂之	曰：「吾非獨
WX 46	夜夢	受秋駕，		明日往朝	師，師			曰：

LSCQ	愛道	也，恐子之	未可與也。	今日	將	教子以秋駕。」
HNZ 12	愛道於子	也，恐子	不可予也。	今日	將	教子以秋駕。”
WX 6	愛道	也，恐子之	未可與也。	今日	將	教子以秋駕。」司馬彪曰：秋
WX 46				今日	將	教子以秋駕。」司馬彪曰：秋

LSCQ	尹需反走，	北面再拜曰：「	今昔臣夢受之。」
HNZ 12	尹需反走，	北面再拜曰：“臣有天幸，	今夕固夢受之。”
WX 6	駕，法駕也。		
WX 46	駕，法駕也。		

As the synopsis of all four passages shows, both the explicit and the implicit quotations are almost identical, apart from few variant characters and some inserted phrases in *Huai nan zi*. Therefore, they all must go back to the same original text. As for the explicit quotations in the *Wen xuan*, we would expect

<sup>173</sup> Major et al. 2010: 475.

them to be identical. This is not quite the case, as *Wen xuan* 46 is abridged compared with *Wen xuan* 6; on the other hand, two characters to be seen in the latter (無, 夢) are missing in the former. However, such variations are common in quotations. Both implicit quotations in the *Lü shi chun qiu* and the *Huai nan zi* share individual characters as well as several phrases, that are omitted in the explicit quotations.<sup>174</sup>

In all likelihood, a pre-Han version of the *Zhuang zi* must have been the source which was then used by the compilers of the *Lü shi chun qiu* who, as was said at the beginning, must have had a *Zhuang zi* at hand since in one instance they quote it explicitly. The *Huai nan zi* also used it but, as it is usual for this text, altered it to adapt it to its own agenda. Both the *Lü shi chun qiu*'s and the *Huai nan zi*'s implicit quotations precede the Liu Xiang version of the *Zhuang zi*. Note that the *Wen xuan* quotations – which must derive from the Han version – are closer to the *Lü shi chun qiu* than to the *Huai nan zi* which lets us corroborate the above conclusion that if a *Huai nan* version of the *Zhuang zi* ever was compiled – as Harold Roth has postulated – it had no influence on the Liu Xiang version.<sup>175</sup>

#### 4.1.3 The Lord of Liang

A last example of this category is somewhat more complicated. First of all, the respective explicit quotations will be presented. Then they will be arranged in a synopsis, from which a tentative reconstruction of the pericope will be derived, followed by its English translation. Then implicit quotations will be added which will serve to control as it were this tentative reconstruction.

Both the *Yi wen lei ju* and the *Tai ping yu lan* contain three explicit *Zhuang zi* quotations each – of unequal length – that once belonged to one and the same pericope which is missing in the received text. The *Yi wen lei ju* extracts are the following ones:

(莊子)又曰。宋景公時。大旱三年。卜之。以人祠乃雨。公下堂頓首曰。吾所以求雨。將自當之。言未卒。天下大雨方千里者何。德於天而惠於民也。<sup>176</sup>

<sup>174</sup> All individual properties of the four quotations will, of course, be given due discussion in the critical edition currently under construction.

<sup>175</sup> For a systematic investigation of the *Huai nan zi* quotations from *Zhuang zi* see the article “Reconstructing the *Zhuang zi* – early sources” (forthcoming).

<sup>176</sup> *Yi wen lei ju* 2: 27.

and

莊子曰。梁君出獵。見白鴈羣。下轂弩欲射之。道有行者。梁君謂行者止。行者不止。白鴈羣駭。梁君怒。欲射行者。其御公孫龍止之。梁君怒曰。龍不與其君。而顧他人。對曰。昔宋景公時大旱。卜之。必以人祠乃雨。景公下堂頓首曰。吾所以求雨。為民也。今必使吾以人祠乃雨。將自當之。言未卒而大雨。何也。為有德於天而惠於民也。君以白鴈故而欲射殺人。主君譬人無異於豺狼也。梁君乃與龍上車歸。呼萬歲。曰。樂哉。人獵皆得禽獸。吾獵得善言而歸。<sup>177</sup>

as well as

莊子曰。梁君出獵。見白鴈羣。君欲射之。道有行者駭之。君怒。欲射行者。其御公孫龍。下車撫矢曰。昔先公時。大旱三年。卜之。以人祠乃雨。公下堂頓首曰。吾欲所以求雨。以為民也。當之。言未卒而天大雨。方千里者何。為於天而惠於民。今君主以白鴈而欲殺人乎。<sup>178</sup>

The first two as preserved in the *Tai ping yu lan* are:

莊子曰：宋景公時。大旱三年，卜云：以人祀乃雨。公下堂頓首曰：吾所求雨者，為人。今殺人，不可！將自當之。言未卒，天大雨，方千里。<sup>179</sup>

and

（莊子）又曰：梁君出獵，見白鴈羣集。梁君下車，轂弓欲射之。道有行者，白鴈羣駭，梁公怒，欲殺行者，其御公孫龍下車，撫其心。梁君忿然作色而怒曰：龍不與其君，而顧與他人，何也？公孫龍對曰：昔者齊景公之時，天旱三年，卜之曰：必以人祠乃雨。景公下堂頓首曰：吾所以求雨者，為民也。今必使吾以人祠，乃且雨，寡人將自當之。言未卒而天大雨，方千里。何？為有德於天而惠施民也。今主君以白鴈之故而欲煞人，無異於虎狼。梁君援手與上車，歸入郭門，呼萬歲曰：樂哉，今日也！人獵皆禽獸，吾獵獨得善言而歸。<sup>180</sup>

This second quotation was obviously the one used by WANG Yinglin as 31st example of his small collection of lost *Zhuang zi* passages.<sup>181</sup> The third *Zhuang zi* quotation of the same pericope and to be found in *Tai ping yu lan* is

（莊子）又曰：梁君出獵，見白鴈羣，下車，轂弩欲射之。道有行者不止，白鴈羣駭。梁君怒，欲射行者。其御公孫龍撫轡曰：今主君以因白鴈故而欲射殺人，無異於虎狼。梁君援其手與歸，呼萬歲曰：樂哉！今日獵也。人皆得獸，吾獨得善言。<sup>182</sup>

177 *Yi wen lei ju* 66: 1172.

178 *Yi wen lei ju* 100: 1722.

179 *Tai ping yu lan* 10: 6a.

180 *Tai ping yu lan* 457: 3b.

181 *Kun xue ji wen* 36a, translated by Knaut 1982: 65–66.

182 *Tai ping yu lan* 832: 1b.



LJ 002	德	於天而惠於民也。											
LJ 066	有	德	於天而惠於民也。	君	以	白鴈	而欲射	殺					
LJ 100			於天而惠於民。	今	君主	以	白鴈	故	而欲 殺				
YL 10													
YL 457	有	德	於天而惠施民也。	今	主君	以	白鴈之	故	而欲 煞				
YL 832				今	主君	以因	白鴈	故	而欲射 殺				
LJ 002													
LJ 066	人。	主君譬人	無異於豺狼也。	梁君乃		與龍	上車	歸。					
LJ 100	人乎。												
YL 10													
YL 457	人，		無異於虎狼。	梁君	援	手	與	上車，	歸入郭門，				
YL 832	人，		無異於虎狼。	梁君	援其	手	與	上車，	歸，				
LJ 002													
LJ 066	呼萬歲。	曰。	樂哉。	人獵	皆得	禽	獸。	吾	獵				
LJ 100									得				
YL 10													
YL 457	呼萬歲。	曰：	樂哉，	今日	也！	人獵	皆	禽	獸，	吾	獵	獨	得
YL 832	呼萬歲。	曰：	樂哉！	今日	獵	也。	人	皆得	獸，	吾	獵	獨	得
LJ 002													
LJ 066	善言而歸。												
LJ 100													
YL 10													
YL 457	善言而歸。												
YL 832	善言。												

In order to undertake a tentative reconstruction\* of the lost *Zhuang zi* pericope from this synopsis, the following rules will be observed:

1. the earliest testimonies will be considered in the first place,
2. from these earliest testimonies the longest one will be taken as the basis,
3. *lacunae* in the basic text are to be complemented a) by other testimonies belonging to the group of the earliest ones (put into brackets ⟨ ⟩), b) by testimonies belonging to the group of the next younger quotations (put into brackets ⟨ ⟩).

As the *Yi wen lei ju* is the earlier source (AD 604) and the *Zhuang zi* quotation in *YWLJ* 66: 1172 is the longest, this is taken as basic text, to be complemented by phrases taken from *YWLJ* 2: 27 and 100: 1722. The *Tai ping yu lan* is the younger source (ordered early in 977 and completed probably in 982) and will only be taken into account when its relevant *Zhuang zi* quotations have phrases or characters that are not already seen in the *YWLJ* quotations.<sup>183</sup>

<sup>183</sup> More details will be discussed in the critical edition currently under construction

Adhering to these rules we obtain the following tentative reconstruction\* of the lost *Zhuang zi* pericope:

*Tentative Reconstruction\* of the lost Zhuang zi pericope*

梁君出獵，見白鴈羣。〈梁君〉下〈車〉轂弩。欲射之。道有行者，梁君謂行者止。行者不止。白鴈羣駭。梁君怒。欲射行者。其御公孫龍〈下車，撫矢曰。〉止之。梁君〈忿然作色而〉怒曰：龍不與其君，而顧〈與〉他人，〈何也？公孫龍〉對曰：昔〈者〉宋景公〈之〉時，〈天〉大旱三年。卜之。〈云〉：必以人祠乃雨。景公下堂頓首曰。吾所以求雨〈者〉，為民也。今必使吾以人祠，乃〈且〉雨，〈寡人〉將自當之。言未卒而〈天〉大雨。〈方千里者〉何也。為有德於天而惠於民也。〈今〉君〈主〉以白鴈〈之故〉而欲射殺人〈乎〉。主君譬人無異於豺狼也。梁君乃〈援其手〉與龍上車歸。〈入郭門〉，呼：萬歲。曰：樂哉。〈今日獵也〉。人獵皆得禽獸。吾獵〈獨〉得善言而歸。

This may be translated as

The Lord of Liang went hunting and saw a flock of white wild geese. [The Lord of Liang] descended [from the carriage], drew his bow and wished to shoot them. [As] there was a traveller on the road, the Lord of Liang told the traveller to stop. The traveller did not stop and the white wild geese were startled [and flew off]. The Lord of Liang became enraged and wanted to shoot the traveller. [But] his driver, Gongsun Long, descended the carriage and led his hand on the arrow, saying: "Stop it!" The Lord of Liang being indignant and changing the colour [of his face] said in anger: "Long, why do you not side with your lord, but rather turn your head away and side with another person?" Gongsun Long replied: "Formerly, in the time of Duke Jing of Song, a great heavenly [sent] drought lasted for three years. They consulted the oracle bones about it, which said: "It is necessary to take a human [being] and sacrifice her, then it will rain." Duke Jing went down into the ancestral hall, bowed [his] head and said: "As for why I am beseeching rain, it is on behalf of the people. Today it is necessary to let me take a human [being] and sacrifice him and then it will rain. I the unworthy man will myself act as [the victim]." When the speech was not yet finished, Heaven had it rain tremendously over an area of a thousand square miles. Why was it? It was because he showed virtue towards Heaven and kindness towards [his] people. Now, your Lordship as the ruler [only] because of white wild geese wants to shoot and kill a human [being], alas. Your ruling Lordship can be compared with a man who has no difference to a wolf." The Lord of Liang then pulled his hand and, together with [Gongsun Long], ascended the carriage and returned. Upon entering the gate of the city-wall, he exclaimed: "Ten thousand years", and said: "What a happy one was my today's hunt! [When other] people go hunting, they all obtain birds or beasts, [when] I went hunting I returned having obtained an excellent speech."

Apart from these explicit quotations, several implicit quotations of the same lost *Zhuang zi* pericope can be found in works of the Former Han dynasty. Two are to be seen in works assembled by Liu Xiang – the *Xin xu* 新序 and the *Shuo yuan* 說苑 – and are, therefore, of special interest. Since Liu Xiang was, as was said above, responsible for the standardized *Zhuang zi* text, we would expect that the implicit *Zhuang zi* quotations in his other works are identical with the text of his



*Zhuang zi* redaction. And if the text of the explicit quotations, identified as lost pericopes, were removed from the *Zhuang zi* by Guo Xiang, they ought to represent the pre-Guo Xiang state of the text, in other words: the Han dynasty or Liu Xiang redaction. If these assumptions were correct, these implicit quotations in Liu Xiang's own works ought to be identical with the text reconstructed from the explicit quotations. This shall now be tested.

First, the respective part of the *Xin xu* is given:<sup>184</sup>

梁君出獵，見白鴈群，梁君下車，彀弓欲射之。道有行者，梁君謂行者止，行者不止，白鴈群駭。梁君怒，欲射行者。其御公孫襲下車，撫矢曰：君止。梁君忿然作色而怒曰：襲不與其君，而顧與他人，何也？公孫襲對曰：昔齊景公之時，天大旱三年，卜之曰：必以人祠，乃雨。景公下堂頓首曰：凡吾所以求雨者，為吾民也，今必使吾以人祠乃且雨，寡人將自當之。言未卒而天大雨方千里者，何也？為有德於天而惠於民也。今主君以白鴈之故而欲射人，襲謂主君言無異於虎狼。梁君援其手與上車，歸入廟門，呼萬歲，曰：幸哉！今日也他人獵，皆得禽獸，吾獵得善言而歸。

The second implicit quotation of the same pericope comes from the *Shuo yuan*. The *Shuo yuan* we have today is no longer the original one – in 20 *pian* as stated in the *Bie lu*, or 20 *juan* as listed in the *Sui shu*<sup>185</sup> and Fujiwara Sukeyo's catalogue –, as by the Northern Song period a complete text no longer existed.<sup>186</sup> Zeng Gong 曾鞏 (1019–1083) had combined the 5 *pian* at his disposal (most likely the 5 *juan* preserved in the imperial library according to the *Chong wen zong mu* 崇文總目 [extant is the abridged version, listing the titles and *juan*-numbers only, published in 1144]) with the 15 *pian* he was able to obtain from other scholars, thereby splitting *pian* 19 (“*Xiu wen*” 修文) into two parts.<sup>187</sup> However, lost parts can be found quoted in *lei shu*. Accordingly, the quotation preserved in *Shuo yuan* and corresponding to the *Xin xu* paragraph, although no longer in the received text, is to be found in *Tai ping yu lan* 390: 5b and goes like this:

《說苑》曰：梁君出獵，見白鴈群。梁君下車，彀弓欲射之。道有行者觀，勸梁君止，鴈群駭，梁君怒，欲殺行者。其御公孫龍下車對曰：昔者齊景公之時，天旱三年，卜之曰：必以人祠乃雨。景公曰：吾昔所以求雨者，為吾民也。今以人祠乃雨，寡人將自當之。言未卒，天大雨方千里。今主君以白鴈故而欲殺之，無異於狼虎。梁君援其首與上車，歸入郭門，呼萬歲，曰：樂哉！今日獵也，獨得善言。

<sup>184</sup> *Xin xu* 2: 6b.

<sup>185</sup> *Sui shu* 34: 997.

<sup>186</sup> Knechtges in Loewe 1993: 444.

<sup>187</sup> Knechtges 1993: 444 also mentions that, later, *pian* no.20 was supplied from a text obtained from Korea.

The synopsis of both reads:

Synopsis 17: *Xin xu* 2 and *Shuo yuan ap.* TPLYL 390: 5b

XX	梁君出獵，見白鴈群，梁君下車，彀弓欲射之。道有行者，	梁君謂行者止，行者不	止，	
SY	梁君出獵，見白鴈群。梁君下車，彀弓欲射之。道有行者觀，勸	梁君	止，	
XX	白	鴈群駭。梁君怒，欲射行者。其御公孫襲下車，撫矢曰：君止。梁君忿然作色而怒曰：		
SY	鴈群駭，梁君怒，欲殺行者。其御公孫龍下車			
XX	襲不與其君，而顧與他人，何也？公孫襲	對曰：昔	齊景公之時，天大	旱三
SY		對曰：昔者	齊景公之時，天	旱三
XX	年，卜之曰：必以人祠，乃雨。景公下堂頓首	曰：凡	吾	所以求雨者，為吾民也，今必
SY	年，卜之曰：必以人祠，乃雨。景公	曰：	吾昔	所以求雨者，為吾民也。今
XX	使吾	以人祠乃且	雨，寡人將自當之。言未卒而天大雨方千里者，何也？為有德於天而惠	
SY	以人祠乃	雨，寡人將自當之。言未卒，天大雨方千里。		
XX	於民也。	今主君以白鴈之故而欲射人，襲謂主君言	無異於虎很。梁君援其手與上	
SY		今主君以白鴈故而欲殺之，	無異於狼虎。梁君援其首與上	
XX	車，歸入廟門，呼萬歲，曰：幸哉！今日也他人	獵，皆得禽獸，吾	獵得善言而歸。	
SY	車，歸入郭門，呼萬歲，曰：樂哉！今日	獵也，	獨得善言。	

Although considerably shorter, the *Shuo yuan* fragment shows only minor differences (marked yellow) with the *Xin xu* version, which may have occurred during the process of copying it into the *Tai ping yu lan*. If we select the more complete *Xin xu* fragment and match it with the tentative reconstruction\* of the *Zhuang zi* pericope as obtained above, we get an almost perfect match (phrases of the reconstructed\* text matched by the *Xin xu* passage are marked green):

梁君出獵，見白鴈羣。〈梁君〉下〈車〉彀弩。欲射之。道有行者，梁君謂行者止。行者不止。白鴈羣駭。梁君怒。欲射行者。其御公孫龍〈下車，撫矢曰。〉止之。梁君〈忿然作色而〉怒曰：龍不與其君，而顧〈與〉他人，〈何也？公孫龍〉對曰：昔〈者〉宋景公〈之〉時，〈天〉大旱三年。卜之。〈云〉：必以人祠乃雨。景公下堂頓首曰。吾所以求雨〈者〉，為民也。今必使吾以人祠，乃〈且〉雨，〈寡人〉將自當之。言未卒而〈天〉大雨。〈方千里者〉何也。為有德於天而惠於民也。〈今〉君〈主〉以白鴈〈之故〉而欲射殺人〈乎〉。主君譬人無異於豺狼也。梁君乃〈援其手〉與龍上車歸。〈入郭門〉，呼：萬歲。曰：樂哉。〈今日獵也〉。人獵皆得禽獸。吾獵〈獨〉得善言而歸。

This means that the reconstruction\* of the lost *Zhuang zi* pericope, based on the explicit quotations in both the *Yi wen lei ju* and *Tai ping yu lan*, in all likelihood represents the pericope as it existed in the lost Liu Xiang standardized version.

## 4.2 Lost sentences no longer to be seen in the *textus receptus*

Less spectacular than the discovery of entire pericopes, but no less important in view of textual criticism, is the identification of lost sentences which once belonged to pericopes that are still extant. The *Yi wen lei ju* and the *Chu xue ji* 初學記 (of before AD 742) as well as the *Tai ping yu lan*, e. g., contain an explicit *Zhuang zi* quotation to the effect:<sup>188</sup>

莊子曰。朽瓜化為魚。物之變（也）。<sup>189</sup>

The *Zhuang zi* says: Rotten melons become fish, [this is] the transformation of things.

These two sentences are lacking in the *Zhuang zi textus receptus*. The latter part also appears in just another explicit *Zhuang zi* quotation to be seen in the *Yi wen lei ju*:<sup>190</sup>

莊子曰：鷓為鷓。鷓為布穀。布穀復為鷓。此物變也。

The *Zhuang zi* says Kites become sparrow-hawks, sparrow-hawks become cuckoos, cuckoos again become sparrow-hawks; this is the transformation of things.

Again, these sentences are missing in the received *Zhuang zi*. Furthermore, the *Tai ping yu lan* preserves the following explicit *Zhuang zi* quotation whose text is absent in the received *Zhuang zi*:<sup>191</sup>

（莊子）又曰：馬血之為鱗也，人血之為野火也，鷓之為鷓，鷓之為布穀，布穀之復為鷓也，鷓之為蛤也，田鼠之為鷓也，老韭之為芫也，老猿之為猿也，魚卵之為蟲也，此皆物之變者。

The very similar phrases 物之變 (YWLJ), 此物變也 (YWLJ) and 此皆物之變者 (TPYL) may indicate that they, together with the above sentences of the *Yi wen lei ju* and *Chu xue ji*, once belonged to one and the same pericope. Indeed, they can be found in the post-Han text *Lie zi* 列子.<sup>192</sup> Most important for our purposes is the fact that the first half of the *Lie zi* pericope in question and its last

<sup>188</sup> Also see Wang 1994, vol. 3: 1402.

<sup>189</sup> *Yi wen lei ju* 87: 1504, *Chu xue ji* 28: 684 and *Chu xue ji* 30: 740, *Tai ping yu lan* 978: 5a and *Tai ping yu lan* 935: 4b.

<sup>190</sup> *Yi wen lei ju* 91: 1589.

<sup>191</sup> *Tai ping yu lan* 887: 07b.

<sup>192</sup> More on the text *Lie zi* and the characteristics of its implicit *Zhuang zi* quotations as well as on its explicit quotations in Zhang Zhan's commentary will be said in a subsequent paper.

sentences in fact do occur in the received *Zhuang zi*. The *Zhuang zi* pericope is presented first:<sup>193</sup>

列子行，食於道從，見百歲髑髏，撻蓬而指之曰：唯予與女知而未嘗死，未嘗生也。若果養乎？予果歡乎？種有機？得水則為繼，得水土之際則為蛙蟻之衣，生於陵屯，則為陵烏，陵烏得鬱棲，則為烏足，烏足之根為蜻蟻，其葉為胡蝶。胡蝶胥也化而為蟲，生於灶下，其狀若脫，其名為鷓掇。鷓掇千日為鳥，其名為乾餘骨。乾餘骨之沫為斯彌，斯彌為食醢。頤輅生乎食醢，黃輓生乎九猷，脊芮生乎腐蠹。羊奚比乎不筲久竹生青寧，青寧生程，程生馬，馬生人，人又反入於機。萬物皆出於機，皆入於機。

In Watson's translation:<sup>194</sup>

Lie zi was on a trip and was eating by the roadside when he saw a hundred-year-old skull. Pulling away the weeds and pointing his finger, he said, "Only you and I know that you have never died and you have never lived. Are you really unhappy? Am I really enjoying myself?" The seeds of things have mysterious workings. In the water they become Break Vine, on the edges of the water they become Frog's Robe. If they sprout on the slopes they become Hill Slippers. If Hill Slippers get rich soil, they turn into Crow's Feet. The roots of Crow's Feet turn into maggots and their leaves turn into butterflies. Before long the butterflies are transformed and turn into insects that live under the stove; they look like snakes and their name is Chu tuo. After a thousand days, the Chu tuo insects become birds called Dried Leftover Bones. The saliva of the Dried Leftover Bones becomes Si mi bugs and the Si mi bugs become Vinegar Eaters. Yi lu bugs are born from the Vinegar Eaters, and Huang-shuang bugs from Jiu you bugs. Jiu you bugs are born from Mou rui bugs and Mou rui bugs are born from Rot Grubs and Rot Grubs are born from Sheep's Groom. Sheep's Groom couples with bamboo that has not sprouted for a long while and produces Green Peace plants. Green Peace plants produce leopards and leopards produce horses and horses produce men. Men in time return again to the mysterious workings. So all creatures come out of the mysterious workings and go back into them again.

In the *Lie zi* pericope,<sup>195</sup> the parts that to a large extent match the *Zhuang zi* text are marked green:

子列子適衛，食於道，從者見百歲髑髏，撻蓬而指，顧謂弟子百豐曰：「唯予與彼知而未嘗生未嘗死也。此過養乎？此過歡乎？」種有機：得水為蕒，得水土之際，則為蛙蟻之衣。生於陵屯，則為陵烏。陵烏得鬱栖，則為烏足。烏足之根為蜻蟻，其葉為胡蝶。胡蝶胥也，化而為蟲，生灶下，其狀若脫，其名曰鷓掇。鷓掇千日，化而為鳥，其名曰乾餘骨。乾餘骨之沫為斯彌。斯彌為食醢頤輅。食醢頤輅生乎食醢黃輓，食醢黃輓生乎九猷。九猷生乎脊芮，脊芮生乎腐蠹。羊肝化為地皋，馬血之為轉鄰也，人血之為野火也。鷓之為鷓，鷓之為布穀，布穀久復為鷓也，鷓之為蛤也，田鼠之為鷓也，朽瓜之為魚也，老韭之為莧也，老榆之為猿也，魚卵之為蟲。夏爰之獸自孕而生曰類。河澤之鳥視而生曰鷓。

193 *Zhuang zi* 18.40.

194 Watson 1968: 195–196.

195 *Lie zi zhu* 1: 3.

純雌其名大腰，純雄其名稚蜂。思士不妻而感，思女不夫而孕。后稷生乎巨跡，伊尹生乎空桑。厥昭生乎濕。醯雞生乎酒。羊奚比乎不筍久竹生青寧，青寧生程，程生馬，馬生人。人久入於機。萬物皆出於機，皆入於機。

Obviously, the whole middle part of the *Lie zi* pericope 1.4 has no counterpart in the received *Zhuang zi*. It reads in Graham's translation:<sup>196</sup>

Sheep's liver changes into the goblin sheep underground. Horse's blood becoming the will-o'-the-wisp, man's blood becoming the 'wilderness fire', kites becoming sparrow-hawks, sparrow-hawks becoming cuckoos, cuckoos in due course again becoming kites, swallows becoming oysters, moles becoming quails, rotten melons becoming fish, old leaks becoming sedge, old ewes becoming monkeys, fish roe becoming insects. Beasts of Shanyuan give birth after conceiving by themselves, called *lei*. Birds of the rivers and marshes give birth after looking at each other, called fish-hawks. A creature being solely female – its name is giant tortoise. A creature being solely male, its name is little bee. The men of Si impregnate without intercourse, the women of Si conceive without intercourse. Hou Ji was born from a great footprint, Yi Yin was born from a hollow mulberry tree. Dragon flies are born from moisture, animalculae are born from vinegar.

Looking now at this middle part itself, the above presented explicit *Zhuang zi* quotation from the *Tai ping yu lan*, missing in the *textus receptus*, can – apart from one sentence at the beginning and one sentence in the middle – be mapped on it (marked green):

(... ) 羊肝化為地臯，馬血之為轉鄰也，人血之為野火也。鷓之為鷓，鷓之為布穀，布穀久復為鷓也，鷓之為蛤也，田鼠之為鷓也，朽瓜之為魚也，老韭之為菟也，老踰之為猿也，魚卵之為蟲。喜爰之獸自孕而生曰類。河澤之鳥視而生曰鷓。純雌其名大腰，純雄其名稚蜂。思士不妻而感，思女不夫而孕。后稷生乎巨跡，伊尹生乎空桑。厥昭生乎濕。醯雞生乎酒。 (... )

Moreover, the *Lie zi* sentence 朽瓜之為魚也, although lacking in the *Tai ping yu lan* quotation, is matched by the explicit *Zhuang zi* quotation to be found in the *Yi wen lei ju* (as shown above): 莊子曰：朽瓜化為魚 (... ). Even for the remaining *Lie zi* part for which no explicit quotation of lost *Zhuang zi* phrases was presented so far, evidence can be offered for at least the expression 稚蜂 – which occurs in the sentence 純雄其名稚蜂 – that it, too, must have occurred in the *Zhuang zi* at the corresponding position as Zhang Zhan's 張湛 (fl. AD 370) commentary on this *Lie zi* sentence explicitly quotes Sima Biao's *Zhuang zi* commentary on the (now lost) corresponding sentence, to the effect:

司馬彪云：稚蜂，細腰者，取桑蟲祝之，使似己之子也。

Sima Biao says: "As for 'little bee', a wasp, it fetches mulberry worms and binds them and lets [them] look like its own offspring."

<sup>196</sup> Graham 1960: 21, modified.

This makes it most likely that the whole middle part of the *Lie zi* pericope in fact is part and parcel of the implicit *Zhuang zi* quotation. We, therefore, can now be quite sure that we have indeed recovered an authentic *Zhuang zi* passage within the *Lie zi*, which is more complete than what survives in the *textus receptus*.

It is noteworthy that the *Tai ping yu lan* quotation of *Zhuang zi* which, as we just saw, is in part missing in the received *Zhuang zi* but is preserved in *Lie zi*, is accompanied by Guo Xiang's commentary. This is an indication that the full pericope may still have been present in the original Guo Xiang version but was later lost during the transmission.

A closer look at this *Lie zi* pericope reveals the most likely reason why part of the text is missing in the received *Zhuang zi*. The *Zhuang zi textus receptus* has a sentence beginning with *yang* 羊 (sheep) saying *yang xi bi hu bu xun jiu zhu sheng qing ning* 羊奚比乎不筍久竹生青寧 (“sheep’s servant” combines with bamboo that for a long time has not sprouted and produces the *qingning* [-plant]). In the *Liezi*, the sentence beginning with *yang* 羊 is different, namely *yang gan hua wei di gao* 羊肝化為地皋 (sheep’s liver transforms into the *di gao* [-animal]). Then follows the part which is missing in the received *Zhuang zi* after which the *Lie zi*, too, has the sentence 羊奚比乎不筍久竹生青寧 (“sheep’s servant” combining with bamboo which has not put forth shoots...). Apparently, what had happened with the *Zhuang zi* was a so-called copyist’s *homoeographon*, an omission resulting from similarity in word, or eyeskip: When he wrote down the first character *yang*, his work may have been interrupted or he may have become inattentive for a moment. When he resumed his work, he saw that the last character he had written was *yang*. He then looked for a *yang* in the text to be copied and saw the second instance from which he now continued copying, thus omitting the whole intermediate part of the pericope.<sup>197</sup>

## Envoy

As should have become obvious so far, it is indeed possible to reconstruct sentences, missing parts of pericopes and even entire pericopes of both the Liu Xiang and even the pre-Liu Xiang versions of the *Zhuang zi*. However, without eventually excavated manuscripts at hand it may not be possible to name the titles of all bundles of the pre-Liu Xiang version or to assign individual pericopes to specific bundles. But also for the Liu Xiang redaction it seems impossible to assess the extent of the textual reorganisation carried out by

---

<sup>197</sup> This is a well-known phenomenon in Western text criticism, see, e. g., Dearing 1974: 49.

Guo Xiang. This may have consequences for the arrangement of the text in the critical edition currently under construction.

**Funding:** Present article is the first of a series presenting the results of the project “Textual criticism and critical edition of the ancient Chinese philosophical text *Zhuang zi* (Master Zhuang)”, supported by the Swiss National Science Foundation, grant number 101511–122224

## Bibliography

### Primary sources

- Bai shi liu tie shi lei ji* 白氏六帖事類集, photolithographic repr. of a Song ed. Peiping 1933: Ed. Qinpu.
- Bei tang shu chao* 北堂書鈔, collated, annotated and published by Kong Guangtao 孔廣陶 in a block-print ed. recut from a traced Song ed. in 1888, photographic repr. Tianjin, 1988: Tianjin guji chubanshe.
- Chu xue ji* 初學記, 4 vols., Peking <sup>2</sup>1980: Zhonghua shuju.
- Feng su tong yi jiao shi* 風俗通義校釋, ed. Wu Shuping, Tianjin 1980: Tianjin guji chubanshe.
- Guan zi jiao zheng* 管子校正, *Xin bian Zhu zi ji cheng*, vol. 5, Taipei 1974: Shijie shuju yinxing.
- Guo Qingfan 郭慶藩 (ed.) (1993): *Zhuang zi ji shi* 莊子集釋. 4 vols. Peking: Zhonghua shuju.
- Han shi wai zhuan* 韓詩外傳, ed. in ed. D.C. Lau and Chen Fong Ching (eds.), *A Concordance to the Han shi wai zhuan* 韓詩外傳逐字索引, Hong Kong 1992: The Commercial Press.
- Han shu* 漢書, 12 vols., Peking <sup>3</sup>1975: Zhonghua shuju.
- Huai nan zi* 淮南子, *Xin bian Zhu zi ji cheng*, vol. 7, Taipei 1974: Shijie shuju yinxing.
- Jin shu* 晉書, 10 vols., Peking <sup>2</sup>1982: Zhonghua shuju.
- Jing dian shi wen* 經典釋文, photolithographic repr. of a Song ed., Shanghai 1985: Shanghai guji chubanshe.
- Jiu Tang shu* 舊唐書, 16 vols., Peking <sup>2</sup>1986: Zhonghua shuju.
- Kong zi jia yu* 孔子家語, *Xin bian Zhu zi ji cheng*, vol. 2, Taipei 1974: Shijie shuju yinxing.
- Kun xue ji wen* 困學紀聞, comp. Wang Yinglin 王應麟 (1223–96), *Si ku quan shu*.
- Lie zi ji shi* 列子集釋, ed. Yang Bojun 楊伯峻, Peking 1979: Zhonghua shuju.
- Lie zi zhu* 列子注, *Xin bian Zhu zi ji cheng*, vol. 4, Taipei 1974: Shijie shuju yinxing.
- Lü shi chun qiu xin jiao zheng* 呂氏春秋新校正, *Xin bian Zhu zi ji cheng*, vol. 7, Taipei 1974: Shijie shuju yinxing.
- Lun heng* 論衡, *Xin bian Zhu zi ji cheng*, vol. 7, Taipei 1974: Shijie shuju yinxing.
- Shi ji* 史記, 10 vols., Peking <sup>2</sup>1982: Zhonghua shuju.
- Shi lei fu* 事類賦, Taipei 1969, photolithographic repr. of Ming ed.
- Shi shuo xin yu* 世說新語, *Xin bian Zhu zi ji cheng*, vol. 8, Taipei 1974: Shijie shuju yinxing.
- Shuo yuan* 說苑, *Si bu cong kan*.
- Sui shu* 隋書, 6 vols., Peking 1973: Zhonghua shuju.
- Tai ping yu lan* 太平御覽, 4 vols., Peking <sup>3</sup>1985: Zhonghua shuju.

- Wang Shumin 王叔岷 (ed.) (1994): *Zhuang zi jiao quan* 莊子校詮. 3 vols. Taipei: Institute of History and Philology.
- Wen xuan* 文選, ed. Liu chen zhu Wen Xuan, 3 vols., Peking 1987: Zhonghua shuju.
- Xin xu* 新序, *Si ku shan ben zong shu*.
- Xun zi* 荀子集解, *Xin bian Zhu zi ji cheng*, vol. 2, Taipei 1974: Shijie shuju yinxing.
- Yan zi chun qiu jiao zhu* 晏子春秋校注, *Xin bian Zhu zi ji cheng*, vol. 6, Taipei 1974: Shijie shuju yinxing.
- Yi wen lei ju* 藝文類聚, 4 vols., Shanghai 1985: Shanghai guji chubanshe.
- Zhan guo ce jiao zhu* 戰國策校注, *Si bu cong kan*.
- Zhuang zi* 莊子, ed. in the Harvard-Yenching Institute Sinological Index Series, (quoted as *juan*. line as to be found in the HY-Index): Peking, 1947: Harvard-Yenching Institute.

## Secondary sources

- Bumbacher, Stephan Peter (2012): “Critical edition of *Zhuang zi* – in search of the lost text”. Paper presented at the EACS Conference in Paris, September 2012.
- Chavannes, Edouard (1967–69): *Les mémoires historiques de Se-ma Ts'ien. Traduits et annotés*. (5 vols., originally published 1895-1905) Paris 1967 and (vol. 6) Paris 1969: A. Maisonneuve.
- Crump, James I., Jr. (1970): *Chan-kuo ts'e*. Oxford: Clarendon Press.
- Dearing, Vinton A. (1974): *Principles and Practice of Textual Analysis*. Berkeley: University of California Press.
- Fischer, Paul (2009): “Intertextuality in Early Chinese Masters-Texts: Shared Narratives in *Shi Zi*”. *Asia Maior* 3rd ser. 22: 1–34.
- Graham, Angus C. (1960): *The Book of Lieh-tzu*. London: John Murray.
- Han Ziqiang 韓自強 / Han Chao 韓朝 (2000): “Fuyang chutu de ‘Zhuang zi zapian’ Han jian” 阜陽出土的《莊子雜篇》漢簡. *Daojia wenhua yanjiu* 道家文化研究 18: 10–14.
- Han Ziqiang 韓自強 (ed.) (2004): *Fuyang, Bozhou chutu wenwu wenzi pian* 阜陽亳州出土文物文字篇. Fuyang: Fuyang shi laonian zhuanjia xiehui.
- Hightower, James R. (1952): *Han-shih wai-chuan*. Cambridge, MA: Harvard University Press.
- Kern, Martin (ed.) (2005): *Text and Ritual in Early China*. Seattle, WA: University of Washington Press.
- Knaul (=Kohn), Livia (1982): “Lost Chuang-tzu passages”. *Journal of Chinese Religions* 10: 53–79.
- Knechtges, David R. (1993): “Shuo yüan”. In: Loewe (1993): 443–445.
- Knoblock, John (1988-1994): *Xunzi: A Translation and Study of the Complete Works*. 3 vols. Stanford 1988, 1990, 1994: Stanford University Press.
- Knoblock, John / Riegel, Jeffrey (2000): *The Annals of Lü Buwei. A Complete Translation and Study*. Stanford, CA: Stanford University Press.
- Liao Mingchun (2003): *Chutu jianbai congkao* 出土簡帛叢考. Wuhan: Hubei jiaoyu chubanshe.
- Loewe, Michael (ed.) (1993): *Early Chinese Texts: A Bibliographical Guide*. Berkeley 1993: The Society of the Study of Early China.
- Major, John S. et al. (2010): *The Huainanzi. Liu An, King of Huainan. A Guide to the Theory and Practice of Government in Early Han China*. New York: Columbia University Press.
- Mather, Richard B. (2002<sup>2</sup>): *Shih-shuo hsin-yü: A New Account of Tales of the World*. Ann Arbor, MI: Center for Chinese Studies, The University of Michigan.



- Nienhauser, Jr. William H., et al. (1994): *The Grand Scribes Records. Volume VII: The Memoirs of Pre-Han China*. Bloomington, IN: Indiana University Press.
- Rand, Christopher C. (1983): “Chuang tzu: Text and Substance”. *Journal of Chinese Religions* 11: 5–58.
- Rosemont, Henry, Jr. (ed.) (1991): *Chinese Texts and Philosophical Contexts. Essays Dedicated to Angus C. Graham*. La Salle, IL: Open Court.
- Roth, Harold D. (1991): “Who Compiled the *Chuang Tzu*?”. In: Rosemont (1991): 79–129.
- Roth, Harold D. (1992): *The Textual History of the Huai-nan Tzu*. Ann Arbor: The Association for Asian Studies.
- Roth, Harold D. (1993): “Chuang tzu”. In: Loewe (1993): 56–66.
- Schaberg, David (2005): “Playing at Critique: Indirect Remonstrance and the Formation of *shi* identity”. In: Kern (2005): 194–225.
- Shaughnessy, Edward L. (2001): “The Fuyang *Zhou Yi* and the Making of a Divination Manual”. *Asia Major* 3rd ser. 14.1: 8.
- Teraoka Ryukan 寺岡龍含 (1966): *Tonkô hon Kakushô chû Sôshi Nanka shingyô kenkyû sôron* 敦煌本郭象注莊子南華真經研究總論. Fukui: Fukui Kanbun gakukai.
- Wang Xiangtian 王襄天 / Han Ziqiang 韓自強 (1978): “Fuyang Shuanggudui Xi Han Ruyin hou mu fajue jianbao” 阜陽雙古堆西漢汝陰侯墓發掘簡報. *Wenwu* 1978.8: 12–31 and 98–99.
- Watson, Burton (1968): *The Complete Works of Chuang tzu*. New York: Columbia University Press.