

Metro of Monterrey, Mexico

Autor(en): **Mondorf, Paul**

Objektyp: **Article**

Zeitschrift: **IABSE congress report = Rapport du congrès AIPC = IVBH
Kongressbericht**

Band (Jahr): **14 (1992)**

PDF erstellt am: **12.07.2024**

Persistenter Link: <https://doi.org/10.5169/seals-853226>

Nutzungsbedingungen

Die ETH-Bibliothek ist Anbieterin der digitalisierten Zeitschriften. Sie besitzt keine Urheberrechte an den Inhalten der Zeitschriften. Die Rechte liegen in der Regel bei den Herausgebern.

Die auf der Plattform e-periodica veröffentlichten Dokumente stehen für nicht-kommerzielle Zwecke in Lehre und Forschung sowie für die private Nutzung frei zur Verfügung. Einzelne Dateien oder Ausdrucke aus diesem Angebot können zusammen mit diesen Nutzungsbedingungen und den korrekten Herkunftsbezeichnungen weitergegeben werden.

Das Veröffentlichen von Bildern in Print- und Online-Publikationen ist nur mit vorheriger Genehmigung der Rechteinhaber erlaubt. Die systematische Speicherung von Teilen des elektronischen Angebots auf anderen Servern bedarf ebenfalls des schriftlichen Einverständnisses der Rechteinhaber.

Haftungsausschluss

Alle Angaben erfolgen ohne Gewähr für Vollständigkeit oder Richtigkeit. Es wird keine Haftung übernommen für Schäden durch die Verwendung von Informationen aus diesem Online-Angebot oder durch das Fehlen von Informationen. Dies gilt auch für Inhalte Dritter, die über dieses Angebot zugänglich sind.

Metro of Monterrey, Mexico

Méto de Monterrey, Mexique

Die Metro von Monterrey, Mexico

Paul MONDORF
Senior Bridge Eng.
J. Muller Int.
San Diego, CA, USA



Paul Mondorf graduated from the Technical University of Denmark in 1953 with a masters degree in civil engineering. For the past 35 years he has been involved in the design engineering and construction of concrete buildings and bridges throughout the world.

SUMMARY

In January 1987, the State of Nuevo Leon, Mexico, decided to build the first line of an elevated light rail system for the town of Monterrey. The guideway consists of an 18.7 kilometer long precast segmental concrete box girder. The project includes 619 spans with an average length of 27 meters. The design and construction of this elevated guideway were completed in two and a half years.

RÉSUMÉ

En janvier 1987, l'Etat du Nouveau Leon au Mexique décida de construire la première ligne d'un méto aérien pour la ville de Monterrey. Cette structure ferroviaire, constituée par un caisson en béton à voussoirs préfabriqués, s'étend sur 18,7 kilomètres. Le projet comprend 619 travées de 27 mètres de longueur moyenne. Les études et la construction de cet ouvrage ferroviaire ont été complétées en deux ans et demi.

ZUSAMMENFASSUNG

Im Januar 1987 entschloss sich der Staat Nuevo León zum Bau der ersten Linie eines Hochbahntransportsystems in der Stadt Monterrey. Die 18.7 Kilometer lange Viaduktanlage umfasst Spannbetonbrücken über 619 Felder mit einer mittleren Spannweite von 27 Metern, die als Einzelkastenträger in Segmentbauweise hergestellt wurden. Entwurf und Errichtung des Hochbahnviaduktes benötigten nur zweieinhalb Jahre.



Monterrey is a rapidly growing industrial state capital of Northern Mexico, a hundred and fifty miles south of the United States/Mexican border.

Its present population is estimated at 3 1/2 million inhabitants; the city is quite widespread among the counterforts of the Sierra-Madre Mountains. Most residential areas are one-story family dwellings or generally not more than 4-5 story multi-family houses. The city has a good system of radial and belt roads for rapid vehicle traffic. However, the larger part of the population is totally dependant on public transport, mostly buses, which are noisy and polluting and already overloading the city center.

The construction of a mass transit system was proposed and underground as well as on the ground and aerial solutions were examined. Preference was given to a light rail system, placed on an overhead structure built within the existing street area, a solution which combines efficiency and economy.

In January, 1987, the STATE OF NUEVO LEON decided to build a first line, 18.7 km long, and in November of the same year a public utility called METRORREY was created to transform that decision into reality.

High construction speed was an absolute must. The construction time was initially set at some 24 months.

J. Muller International proposed a segmental bridge concept to the contractor Construmetro. This concept was selected for the following reasons:

- Quantity savings involved by using a single box girder carrying 2 tracks (11.5 T/axle cars).
- Versatility of the concept allowing for the same equipment (form and assembly truss) to build spans ranging from 15 to 47 meters, as required by the environmental constraints in this very dense urban area.
- Speed of erection.
- Construction of the stations using the typical viaduct box girder for its main supporting structural member.

DESIGN FEATURES

The Metro line will be served by an electric train, each convoy comprising 2, 3, or 4 articulated vehicles, each one 30 meters long on three bogies. The vehicles have traditional wheels rolling on gauge rail track, using rails of 115 lbs/yd (57 kg/m), welded in lengths up to 2700 meters. The double track will be placed on plinths directly on the carrying bridge structure. The current, 1500 V direct, will be served by overhead catenaries, suspended from posts placed on the bridge deck alongside the track. Furthermore, on either side of the track, the bridge deck carries signal posts, cable ditches, maintenance cat-walk and concrete parapets.

Along the line stations will be placed approximately every 1100 meters. The line will have

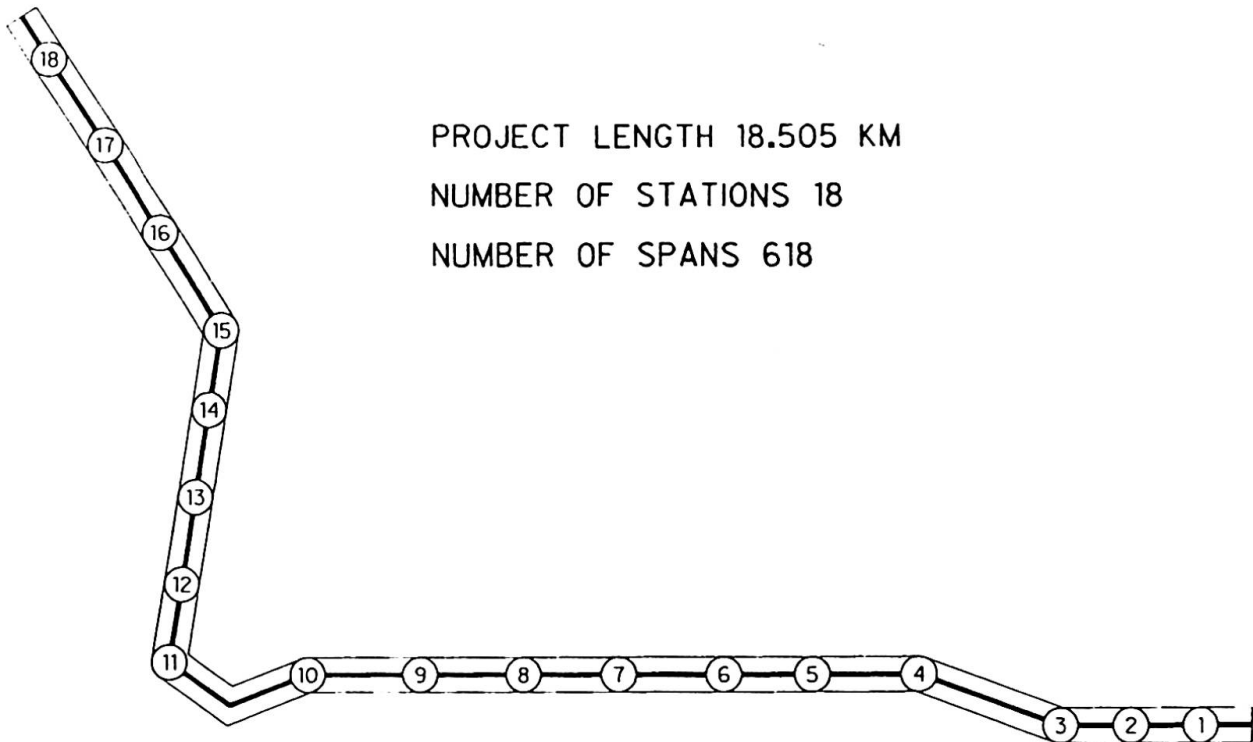

PROJECT LENGTH 18.505 KM
NUMBER OF STATIONS 18
NUMBER OF SPANS 618

GENERAL PLAN

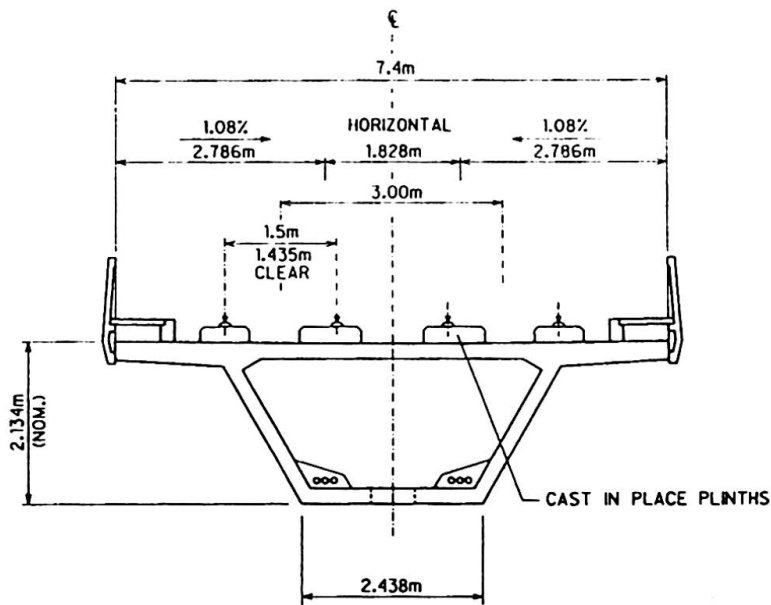

TYPICAL SECTION



13 cross-overs between tracks and two emergency turn-outs. The maintenance shops are placed at the end of the line, where a descent to ground level is provided.

The train has a design speed of 70 km/h. The weight of a vehicle is 40t dead load + 27t live load corresponding to some 400 passengers. The structure is designed for boogie loads of 24 and 20t respectively, spaced approximately 10 m cc, and a coefficient of impact of 0.2. In passenger areas a uniformly distributed live load of 500kg/m² has been taken into account. Derailment load has been considered according to the Sacramento Light Rail Project, Design Criteria 1982, Chapter 7.

The bridge structure has been designed according to AASHTO Standard Specifications.

The width of the bridge deck will be 7.40 meters on straight line increasing to 7.85 meters in sharp curves.

Horizontal curves have a radius of not less than 250 meters and the corresponding superelevation of the rails is achieved through over-height of the plinths. The longitudinal slope of the line generally does not exceed 2%, but in special zones up to 3.5% is accepted. Vertical curves have a minimum radius of 2000 meters.

THE BRIDGE STRUCTURE

The basic structure has raft of bored pile foundations, single columns 5-15 meters high with massive shafts and flared out capitals, and a bridge deck formed as a single box girder, which carries the plinths for the rails.

The major part of the structure was conceived as simply supported spans with span lengths from 15 to 36 meters; the average span has a length of 27 meters. The span lengths were determined mainly by the conditions at street level for the placement of footings and columns.

Moreover, the structure comprises 4 groups of continuous spans 30-47-30 meters long, fitted to solve the crossings of particularly wide avenues.

In certain areas, due to restrictions at ground level or for traffic reasons, the single columns have had to be replaced by straddle bents, each one composed by two columns, placed, for example, at either side of the street, and an overlying post-tensioned concrete girder of double-I-cross section to carry the bridge deck.

The box girder cross section is held constant through-out the bridge, it has a depth of 2.13 m (7 ft), inclined webs 0.305 m (1 ft) thick, a 7.40 m (24 ft, 23in) wide top slab, cantilevered out along both sides of the basic box and a 2.438 m (8 ft) wide bottom slab. Top and bottom slab have a thickness of 0.203 m (8 in). At both ends of a simply supported span and over all intermediate piers of continuous spans, heavy diaphragms are provided.

The box girders are all precast segmental requiring basically two different types of segments, namely typical segments up to 3 meters long, and pier segments 1.5 or 1.2 meters long, in slightly different versions for simply supported and continuous spans respectively.

The box girder is post-tensioned longitudinally by tendons anchored in the diaphragms. Over the major part of their lengths, the tendons are running outside the concrete, but



SIMPLY SUPPORTED SPANS

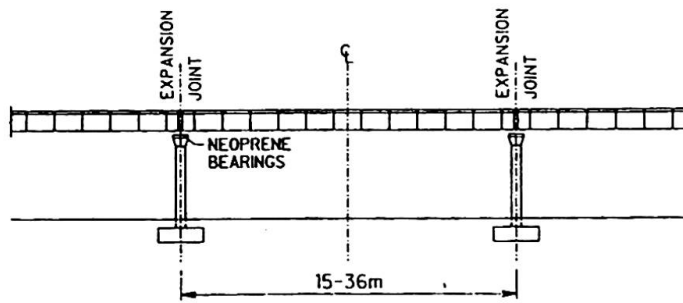

CONTINUOUS SPANS

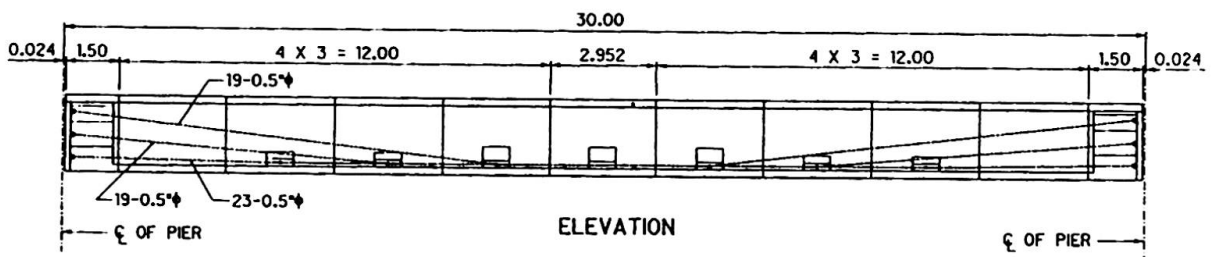
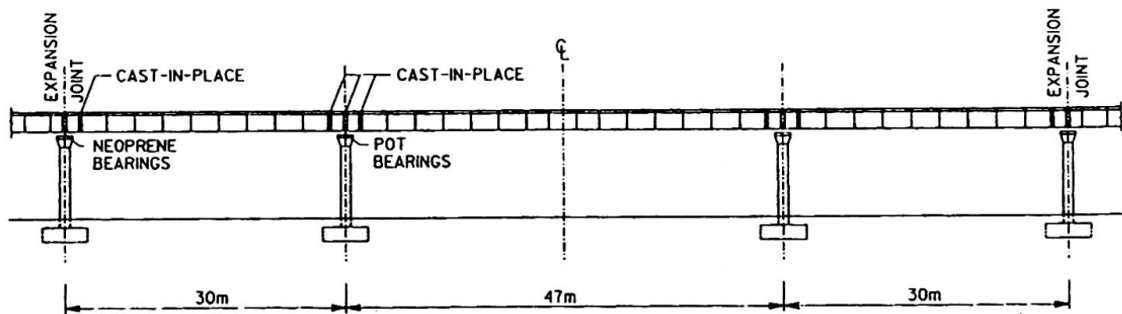

TYPICAL PLAN POST-TENSIONING LAYOUT



inside the box girder, lodged in PE-tubing. The tendons are deviated at specific locations through steel pipes embedded in concrete deviation blocks, cast monolithically with the box segments.

The top slab of the box girder is pre-tensioned transversely and the segments are reinforced with passive reinforcement at an average rate of 120 kg/m³ for typical segments, 160 kg/m³ for pier segments. The concrete design strength is 350 kg/cm².

The box girder was conceived for match cast dry joints with keys provided on all matching surfaces.

The bridge structure also includes 18 metro stations, each one basically composed by a 30 m long central hall, built as a combination of precast and cast-in-situ concrete column/girder/slab structure and on both sides of the central hall a 45 meter long platform area, built as continuous two or three-span segmental bridges of the same cross section as the rest of the bridge, but equipped with brackets to support precast cross beams which will carry the cantilever passenger platforms.

The structure comprises a total of 619 segmental spans requiring some 6503 segments, namely 5265 typical ones and 1238 pier segments.

PRECASTING

In order to manufacture the great number of precast elements required by the project a precasting plant was installed in a 16 ha large area some 20 km north of Monterrey.

In Monterrey the long-bench method was selected for simplicity of execution and for its good economy as a high number of reuses of the benches could be anticipated.

The twenty long benches were made in reinforced concrete. They have lengths from 39 to 53 meters in order to allow for the casting of all types of spans in full length.

The plant was equipped with 26 moulds for typical segments and 14 moulds for pier segments. The moulds for the segments each consist of two lateral forms fixed on trolleys, a central core also fixed on a trolley, and one or two bulkheads. All trolleys have wheel blocks equipped with adjustment screws. The trolleys move on rails cast into the lower parts of the long bench, whereas the segments themselves are cast directly on the raised central part of the bench. The lateral forms can be fitted against the raised part of the bench and kept in place by the tie rods passing through that part of the bench.

ERECTION

The segments are transported by road on low-boys from the precasting plant to the erection sites where they are erected using the span-by-span method.

Following this method the segments for one span are placed on erection girders, adjusted into position so that matching keys will fit perfectly, and stressed together by post-tensioning tendons whereby the span becomes self supporting. The weight of the span is then transferred to the permanent bridge bearings whereafter the trusses are separated from the span and shifted forward in order to serve for the erection of the following span.



The erection girders are modular steel trusses of triangular cross section fitting one under each wing of the segments. The length of the trusses is adjustable from some 24 to 49 meters in order to allow for the erection of spans of all lengths.

The trusses are supported on steel brackets which are suspended from the capitals of the bridge piers and clamped around the pier shafts.

For spans of 36 meters or more, intermediate supports are required; these are provided as modular steel towers which can be installed directly on the pavement.

The trusses, the pier brackets and the intermediate towers have a large number of special features permitting them to accommodate all span lengths and all pier configurations, such as square and skew piers, straddle bents at one or both ends of the spans, spans in curve and continuous spans in the platform areas of the stations.

The erection of a typical span generally takes 2-3 days, but before the erection of the span can be considered complete various finishing operations have to be carried out, preferably in the two-three spans following behind the one being erected. These operations include grouting of tendons, installation of hold-down rods, and possibly some concrete repairs, filling of block-outs, etc.

KEY DATES

Detailed Structural Design, Start	January 1988
Acquisition of the Ground for the Precasting Plant	July 1988
First Segment Cast	October 1988
Erection of First Span	March 1989
End - Precasting of Segments	April 1990
End - Erection of Spans	July 1990

J. MULLER'S SCOPE OF WORK

- Detailed Design of Bridge Superstructures
- Detailed Design of Segments Forms and Erection Trusses
- Technical Assistance to Contractor On Site

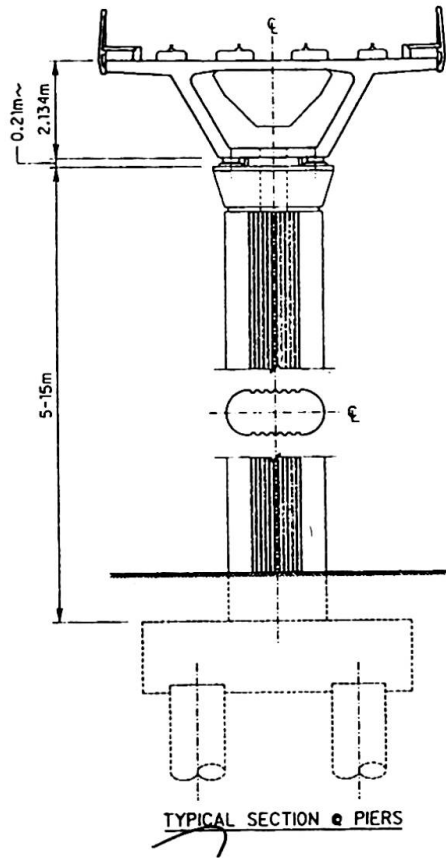

STATIONS:

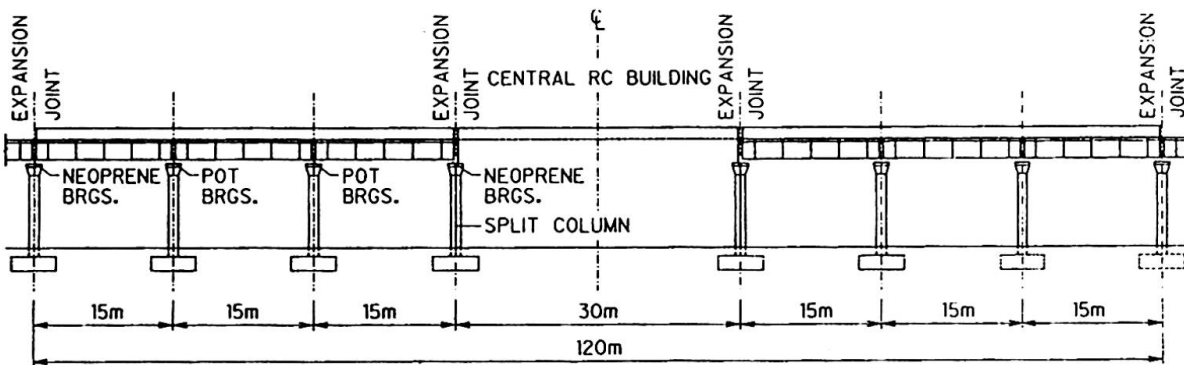
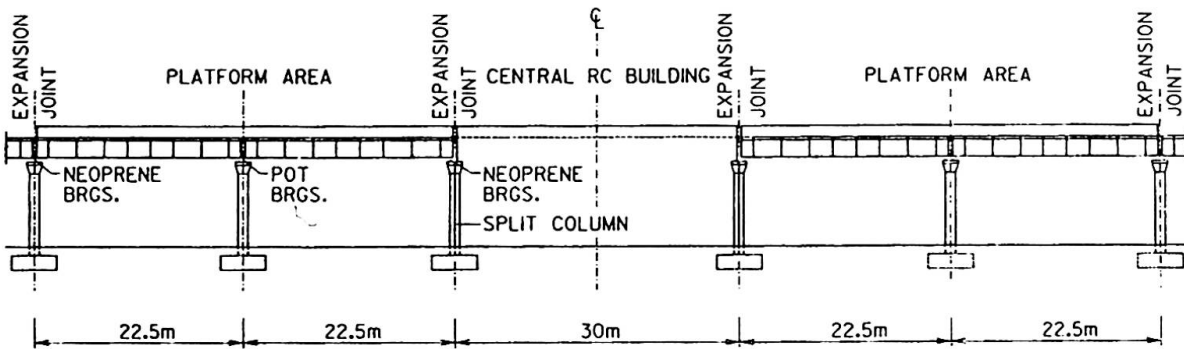

ELEVATION STATIONS



Leere Seite
Blank page
Page vide