

**Zeitschrift:** IABSE congress report = Rapport du congrès AIPC = IVBH  
Kongressbericht

**Band:** 14 (1992)

**Rubrik:** Seminar 6: Bridge management systems

### **Nutzungsbedingungen**

Die ETH-Bibliothek ist die Anbieterin der digitalisierten Zeitschriften. Sie besitzt keine Urheberrechte an den Zeitschriften und ist nicht verantwortlich für deren Inhalte. Die Rechte liegen in der Regel bei den Herausgebern beziehungsweise den externen Rechteinhabern. [Siehe Rechtliche Hinweise.](#)

### **Conditions d'utilisation**

L'ETH Library est le fournisseur des revues numérisées. Elle ne détient aucun droit d'auteur sur les revues et n'est pas responsable de leur contenu. En règle générale, les droits sont détenus par les éditeurs ou les détenteurs de droits externes. [Voir Informations légales.](#)

### **Terms of use**

The ETH Library is the provider of the digitised journals. It does not own any copyrights to the journals and is not responsible for their content. The rights usually lie with the publishers or the external rights holders. [See Legal notice.](#)

**Download PDF:** 15.10.2024

**ETH-Bibliothek Zürich, E-Periodica, <https://www.e-periodica.ch>**



Leere Seite  
Blank page  
Page vide

## **A Decision System for Bridge Management**

Un système de décision pour la gestion des ponts

Ein Entscheidungssystem für Wartung von Stahlbetonbrücken

**Jorge DE BRITO**  
Research Assistant  
Tech. Univ. Lisbon  
Lisboa, Portugal

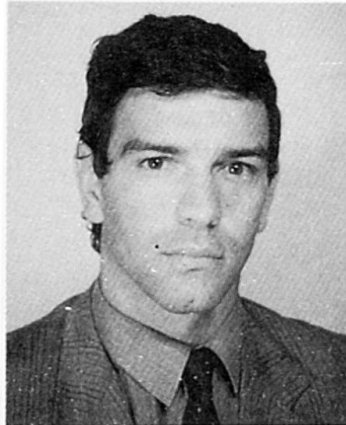

J. de Brito, born in 1959 graduated in Civil Engineering and got his MASc. degree at IST - Tech. Univ. of Lisbon, where he is presently developing his PhD. thesis, as research assistant. His research work deals with deterioration, rehabilitation and management of concrete structures.

**Fernando A. BRANCO**  
Associate Professor  
Tech. Univ. Lisbon  
Lisboa, Portugal



F.A. Branco, born in 1953, is MASc. from Univ. of Waterloo, Canada, and PhD. from Tech. Univ. of Lisbon, where he is Associate Professor. Presently he is director of CMEST - Univ. Structures Research Center, and national representative at RILEM and PCSA. His research and consultant activities deal mainly with bridge and special structure studies.

### **SUMMARY**

In this paper, a decision system for bridge management is presented. It considers data field information obtained from three levels of inspection: current inspection, detailed inspection and structural assessment. Based on this information, the decision system rates the different solutions in order to obtain the best action to take within a maintenance system or a repair/upgrading system.

### **RÉSUMÉ**

Dans cet article on présente un système de décision pour la gestion des ponts. On considère l'information in situ qui provient de trois niveaux d'inspection: inspection courante, inspection détaillée et évaluation structurale. Avec cette information, le système de décision classifie les différents solutions pour l'obtention de la meilleure action à mener, en tenant compte des aspects de manutention ou de réparation/amélioration.

### **ZUSAMMENFASSUNG**

Der Artikel beschreibt ein Entscheidungssystem für die Wartung von Stahlbetonbrücken. Drei überwachungsstufen liefern die entsprechend notwendige Information: gewöhnliche Überwachung, ausführliche Inspektion und Analyse der Struktur. Die so gewonnenen Daten werden von dem Entscheidungssystem benutzt, um unter den Gesichtspunkten der Wartung, Instandsetzung und Verbesserung des Bauwerks das beste Vorgehen zu wählen.





## 1. INTRODUCTION •

Throughout the XX century, reinforced and prestressed concrete has been the most widely used material in construction. Contrary to other materials, concrete does not benefit from a very large experience what led to a precocious reduction in the service life of some concrete bridges. This usually occurred due to an unpredicted evolution of the materials degradation, deficient design construction methods or dramatic increase of the traffic volume / loads.

The disruption of each particular bridge has very high costs for the society. It stops traffic going over it and forces thousands of users to use alternative routes at extra cost and time. Social costs due to the interruption of communications are also to be expected from such a situation. Finally, the costs of rehabilitating a disrupted bridge can be prohibitive, much bigger than the costs of building a stronger and larger structure from the very beginning.

The importance of bridge maintenance versus new bridge construction has arisen in the last decades, due to high deterioration rates that have been observed in these structures. Budgets both for building new bridges and keeping the existing ones are always limited. This means that usually, only a selection of the problems detected can be dealt with. To be aware of the existent problems and to help with rational maintenance decisions, bridge management systems have been developed and are being implemented all over the world.

In this paper, a decision system for concrete bridges management is presented. It considers data field information obtained from three levels of inspection: current inspection, detailed inspection and structural assessment. Based on this information the importance of the anomalies is rated for the current maintenance system. An economical analysis is presented for the decisions within the repair / upgrading system.

## 2. THE INSPECTION PROCEDURE

Within a management system, all the information must be obtained from field inspections that make the inspection sub-system. This information is kept in a data base which is the basis of any future decision procedures. The inspection procedures must be thought on a frame of bridges level and not on a single bridge level, to optimize people and equipment displacements. Inspection procedures usually consist of: current inspections, detailed inspections and structural assessments.

The current inspections are based almost exclusively in direct visual observation which seems to be the most promising diagnosis method. No main structural defects are expected to be found and only maintenance work is to result from the inspections. The recommended period of inspection is 15 months, to allow for the influence of the seasons of the year .

In the detailed inspections, besides direct visual observation, non-destructive in-situ tests of easy performance are to be used to investigate potential sources of problems. Should any main structural anomaly be detected, a structural assessment is to be recommended but not performed right away as these inspections are within the scope of general maintenance. The recommended period for this inspection is around 5 years.

A structural assessment is usually the result of the discovery of a main structural deficiency. It may also be deemed necessary should the options of strengthening or widening the deck need to be weighted. The expected results of this inspection are: the characterization of the structural anomalies, an estimation of the remaining life of the bridge and an estimation of its residual strength. All in-situ diagnosis methods and load and dynamic tests can be used, even though a careful limitation of costs should be taken into account.

## 3. THE MAINTENANCE SYSTEM

Within the management system, maintenance considers the activities related to the repair of small anomalies in order to maintain the bridge service level. The decisions are taken based on a rating of



anomalies according to three main points: rehabilitation urgency, structural importance and affected traffic. This rating procedure considers the results of the inspections, with a list of about 90 anomalies divided into the following groups [1]:

- |  |                                     |
|--|-------------------------------------|
| <b>A - Superstructure global behaviour</b> | <b>F - Joints</b>                   |
| <b>B - Foundations / Abutments</b>         | <b>G - Coating / Watertightness</b> |
| <b>C - Concrete elements</b>               | <b>H - Water drainage</b>           |
| <b>D - Reinforcement / Cables</b>          | <b>I - Secondary elements</b>       |
| <b>E - Bearings</b>                        |                                     |

For concrete bridges, the anomalies are then classified according to [1] [2]:

### Urgency of Rehabilitation

- 0** - immediate action required
- 1** - short-term action required (up to a maximum of 6 months)
- 2** - medium-term action required (usually up to a maximum of 12 to 15)
- 3** - long-term action required (in the next inspection)

### Importance to the Structure's Stability

- A** - anomaly of eminently structural characteristics, associated with main structural elements (deck, beams, columns, abutments and foundations)
- B** - anomaly of semi-structural characteristics associated with main structural elements or structural anomaly associated with secondary structural elements.
- C** - anomaly of semi-structural characteristics associated with secondary structural elements, anomaly of non-structural characteristics or in non-structural elements

### Volume of Traffic Affected by the Anomaly

- $\alpha - t.v. \times d.l. \times k \geq n_1$  [number of vehicles km / day]
  - $\beta - n_1 > t.v. \times d.l. \times k \geq n_2$  [number of vehicles km / day]
  - $\gamma - t.v. \times d.l. \times k < n_2$  [number of vehicles km / day]
- t.v. - average daily traffic volume  
d.l. - detour length  
k - coefficient of traffic obstruction  
n<sub>1</sub> , n<sub>2</sub> - fixed parameters (given by the bridge authorities)

Each anomaly classification-type is then included in one of the priority of action groups:

- 1 - maximum priority** g.n.p.  $\geq 95$
- 2 - high priority**  $80 \leq \text{g.n.p.} \leq 90$
- 3 - medium priority**  $70 \leq \text{g.n.p.} \leq 75$
- 4 - low priority**  $50 \leq \text{g.n.p.} \leq 65$
- 5 - minimum priority**  $30 \leq \text{g.n.p.}$

The classification of the anomalies is done with the following table:

	CLASSIFICATION	POINTS
URGENCY OF REHABILITATION	0	30
	1	25
	2	15
	3	5
IMPORTANCE TO THE STRUCTURE'S STABILITY	A	40
	B	25
	C	15
VOLUME OF TRAFFIC AFFECTED BY THE ANOMALY	$\alpha$	30
	$\beta$	20
	$\gamma$	10



For the maintenance procedures one must act first upon the bridge that has the anomaly with the highest global number of points given; all maintenance work in the same bridge concerning every anomaly of the same type (even if with a smaller number of points) and every anomaly that the management authorities feel can be economically repaired with the same equipment and workmanship should be done.

#### 4. THE REPAIR / UPGRADING SYSTEM

Within the management system, this module considers the important repair works. For decision making, it rates the repair work from an economical point of view, based on a present cost analysis for each option (strengthening, deck widening or bridge replacement).

##### 4.1 The Cost Function

Building a bridge should be looked at as just another form of investment. An initial cost is paid to design and build it, there are in service costs to maintain and repair it and, when its use no more justifies its existence, it is replaced. During its life cycle, the bridge must give benefits valued higher than the sum of all the costs referred above.

For these reasons, for decision making, it is necessary to be able to quantify the global costs of building, using and replacing a bridge and to predict its benefits during its life cycle. In this work, the following cost function was adopted for the Global Costs  $C$  [3]:

$$C = C_0 + C_I + C_M + C_R + C_F - B$$

$C_0$	- initial costs	$C_I$	- inspection costs
$C_M$	- maintenance costs	$C_R$	- repair costs
$C_F$	- failure costs	$B$	- benefits

Initial costs are the costs involved in designing and building the bridge and include: preliminary studies, structural and traffic design, building the bridge and its approaches and load testing before use. The initial costs can be divided in: design costs ( $C_{0D}$ ), construction costs ( $C_{0C}$ ) and testing costs ( $C_{0T}$ ). They can be predicted based on current construction costs, the expected structural type and the bridge deck area and using common sense percentages to partition the costs.

$$C_0 = C_{0D} + C_{0C} + C_{0T}$$

Inspection costs are the ones involved in inspecting regularly the bridge within the maintenance framework, i. e. do not include structural assessments when a main structural deficiency is suspected. The inspection costs of using a bridge can be divided in: labour costs ( $C_{IL}$ ) and equipment costs ( $C_{IE}$ ). They can be estimated based on the bridge dimensions, the authorities current costs and an expected calendar of inspections. It is also possible to rely on past experience in the inspection of the bridge and use linear regression techniques.

$$C_I = C_{IL} + C_{IE}$$

Maintenance costs are the ones involved in keeping the bridge in shape and exclude any main structural work. They are approximately predicted by a percentage  $x'$  of the construction costs of the bridge  $C_{0C}$ :

$$C_M / \text{year} = x' \% C_{0C}$$

This percentage can vary with the bridge's age. It is also possible to predict these costs knowing the bridge dimensions and the current maintenance costs or using linear regression techniques based on the latest years' experience.

Repair costs are the ones involved in doing main structural work (repair, strengthening, deck widening) and include the repair costs themselves and all the costs of any necessary structural assessment. The repair costs along the service life of a bridge can be divided in: structural assessment costs ( $C_{RSA}$ ) and structural repair costs ( $C_{RSR}$ ). They can be approximately estimated considering average repair costs for each type of repair. In the long-term, they can be roughly predicted using a percentage of the construction costs for each year that tends to grow with the bridge's age.

$$C_R = C_{RSA} + C_{RSR}$$

Failure costs are associated with the situations in which the bridge does not fully comply with what is expected of her, i. e. its design functionality. The failure costs of a bridge partially or totally impaired in its function can be divided in: structural failure costs ( $C_{FSF}$ ) and functional failure costs ( $C_{FFF}$ ).

$$C_F = C_{FSF} + C_{FFF}$$

The structural failure costs include all the costs resulting from a structural collapse of the bridge (or a situation in which such collapse is eminent and the bridge has to be closed to traffic). The cost associated with the structural failure can then be obtained from the probability of failure  $P_f$  and the cost of collapse  $C_{FF}$  (even though collapse does not occur under normal circumstances, these costs can still be considered in an economic analysis as insurance costs):

$$C_{FSF} = P_f C_{FF}$$

The cost of collapse can be divided in: bridge replacement costs ( $C_{FFR}$ ), loss of lives and equipment costs ( $C_{FFL}$ ) and architectural / cultural / historical costs ( $C_{FFH}$ ).

$$C_{FF} = C_{FFR} + C_{FFL} + C_{FFH}$$

The functional failure costs  $C_{FFF}$  include all the value attributed to the fact that not all the predicted design traffic can use the bridge (or that its design speed has to be reduced during certain periods of the day or of the existence of an anomaly). The costs of detouring that fraction of traffic and the consequences (delays) caused in the bridges nearby must also be taken into account. This value can be measured in several ways:

- delay in crossing the bridge times volume of traffic delayed ( $C_{FFD}$ ) (Fig.1);
- volume of traffic unable to use the bridge and having to use a detour (this inability can be caused by two reasons: the bridge not being wide enough for the amount of traffic waiting to cross it ( $C_{FFV}$ ); the bridge not having the structural capability to be used by a certain margin of heavy traffic ( $C_{FFL}$ )).

$$C_{FFF} = C_{FFFD} + C_{FFFV} + C_{FFFL}$$

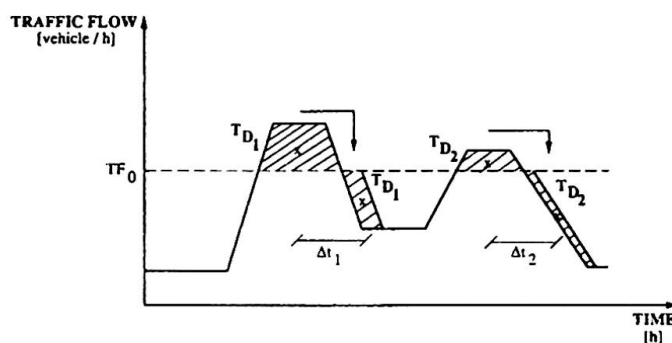

Fig. 1 Simplification proposed for the traffic flow curve versus time of the day



The prediction of such costs relies on traffic surveys (yearly and daily) and future estimates. It is also dependent on the existing alternatives to the bridge being analyzed, its traffic capacity and structural resistance.

Benefits, on the other hand, is what it would be worth to enhance the bridge in order of it to provide a better service (or be of a wider utility) than the one provided at a certain standard situation (usually the design stage). This notion can also be used to compare two solutions of repair, strengthening, deck widening or replacing of a certain bridge (in such a situation, one of the options is considered the standard situation with a benefit nil and the other is evaluated against it). A benefit is equivalent to a negative functional failure cost. This value is, of course, measured in the same way as the cost value.

## 4.2 The Decision Index

The cost function is the basis of the main decisions to consider when an important anomaly that impairs the functionability of the bridge is found. In these situations the possibility of upgrading (widening or strengthening) or replacing the bridge must be considered.

At the beginning of each year, the budget given to the bridge authorities for the works that go beyond maintenance is known and it must be allocated to each bridge. Decisions must be then made according to the cost effectiveness index (CEI) of each option [4]. The CEI indicates how well the proposed workplan actions compare to the no-action option. A CEI value greater than one indicates that the proposed actions are economically better than the no-action option. For each option the CEI may be quantified by:

$$CEI = \frac{(CR + CF - B) \text{ REPAIR}}{(CR + CF - B) \text{ NO REPAIR}}$$

CR - Repair Costs    CF - Failure Costs    B - Benefits

The CEI coefficient may be used at different levels of action, namely:

- Level 1 - To compare different solutions for the repair of the same anomaly
- Level 2 - To obtain the priority of action among the repair of different anomalies within a bridge. The maximum CEI of each anomaly is considered for comparison between different anomalies.
- Level 3 - To obtain the priority of action among the bridges of a network. The accumulated maximum CEI's of each group of repairs within each bridge are considered to compare different bridges.

## 5. CONCLUSIONS

Budgets both for building new bridges and keeping the existing ones are always limited. This means that only a selection of the problems detected can be dealt with, leaving the less important ones as they are. Based on inspection data, a rating of anomalies is presented to optimize maintenance procedures. When repair / upgrading / substitution is considered, the decision is taken with a rating of the deteriorated bridges, based on a cost analysis index.

## 6. REFERENCES

1. BRITO J.; BRANCO F., Concrete Bridges Anomalies Classification System, Proc. II Portuguese Conf. of Structural Engineering, Lisbon, 1990.
2. BRANCO F.; BRITO J., Concrete Bridges Maintenance System - Inspection Techniques and a Rating System, Proc. Int. Conf. on Bridges, Tehran, 1990.
3. BRANCO F.; BRITO J., Bridge Management Systems, Civ. Engin. European Course on Maintenance, Repair and Rehabilitation of Concrete Structures, Lisbon, 1991.
4. AYLON M., The Comprehensive Management of a Bridge Population - A Case Study, Developments in Short and Medium Span Bridge Engineering'90, Toronto, 1990.



## Probabilistic Deterioration Models Used in Bridge Management Systems

Modèle probabiliste de détérioration pour l'entretien des ponts

Probabilistisches Abnutzungsmodell für die Brückenunterhaltung

### Marja-Kaarina SÖDERQVIST

Civil Eng.  
Finnish Nat. Road Adm.  
Helsinki, Finland



Marja-Kaarina Söderqvist, born in 1951, received her Civil Engineering Degree at the Helsinki University of Technology in 1979. She has worked with the Finnish National Road Administration since 1979. M-K Söderqvist is now responsible for the Road Administration's Bridge Management System effort.

### K. Magnus VEIJOLA

Civil Eng.  
Viasys Ltd  
Espoo, Finland

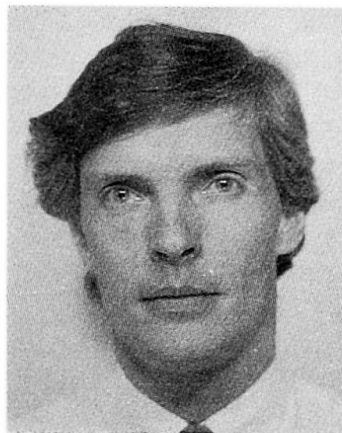

Magnus Veijola, born in 1955, is preparing his Master's Degree on Bridge Management Systems at the Helsinki University of Technology. He has worked with the Viatek Group since 1988 and is now consultant for the Road Administration on Bridge Management Optimization Models.

### SUMMARY

A bridge management system project in progress in Finland is presented. The system applies probabilistic bridge deterioration models to find a condition distribution of the bridges that minimizes maintenance and rehabilitation costs for the existing bridge stock.

### RÉSUMÉ

En Finlande, on développe un système de gestion des ponts depuis 1986. Le système utilise des modèles probabilistes de détérioration des ponts pour déterminer la distribution optimale des conditions, qui minimise les coûts d'entretien et de rénovation des ponts existants.

### ZUSAMMENFASSUNG

Ein Brückenverwaltungssystem, das man in Finnland zur Zeit entwickelt, wird präsentiert. Das System benutzt probabilistische Modelle für Brückenabnutzung, um eine Konditionsverteilung für Brücken zu finden, die die Unterhaltungskosten für bestehenden Brücken minimiert.



## 1. GENERAL ASPECTS

The Finnish National Road Administration (FinnRA) has started the bridge management system development for its 9800 bridges and 2200 culverts in November 1986. This work is made in co-operation with The Technical Research Centre of Finland, Viasys Ltd of Finland and Cambridge Systematics Inc., Cambridge, Massachusetts, USA, and is planned to be completed in 1993.

The goal of this management system is to provide a reliable support tool in decisions related to fund allocation for maintenance, rehabilitation and replacement (MR&R) of existing bridges. The system will minimize MR&R costs while keeping the bridges safe and on a required level of service.

The aim is to find the economically optimal long term condition distribution of the bridge stock within the safety and minimum service levels. The long term optimum solution is a combination of the optimal condition distribution and the optimal repair action distribution.

The system will be employed by the central administration of FinnRA and its thirteen districts to assist in high level bridge policy, long term planning and programming of MR&R investments, and short term evaluation of bridge repair needs and their costs. The work schedules and recommended bridge repair programs are prepared in the districts.

## 2. THE ELEMENTS OF THE BRIDGE MANAGEMENT SYSTEM

### 2.1 The Bridge Database

The whole bridge management system is based on a thorough bridge inspection and condition evaluation. The damages and deterioration detected during the inspections, their exact location and extent are recorded. Also, information on the effect of the damages on bridge bearing capacity, on repair urgency class and the inspector's proposals for repair action and their costs will be described and recorded.

All this information is stored in the bridge database together with bridge structural, administrative and traffic data. Also historical data and information on previous repairs and their realized costs are gathered for further research and bridge age behaviour modelling.

### 2.2 The Network Level System

The management system, when completed, will consist of two parts: a network (bridge stock) level system and a project (individual bridge) level system. This paper is mainly concerned with the network level bridge management system.

The network level system in turn consists of two parts: the long term module to find the ideal optimal condition distribution for the bridge stock and the short term module to find out how to get the bridge stock from the present condition distribution to the optimal distribution.

#### 2.2.1 The Network Level Long Term Analysis

The long term analysis is based on the general idea that the bridge stock has an optimal condition distribution. This optimum is intermediate in the following sense: keeping all bridges in an excellent state at all times would be excessively expensive and, on the other hand, letting the bridge stock



deteriorate badly would cause expensive major repairs. Somewhere in between there is an optimum where the bridge stock can be kept on the same condition level from year to year with the smallest possible amount of funding and still adhere to the safety and level of service requirements.

The optimal condition distribution corresponds to a certain optimal set of repair actions. These repair actions would, in the ideal case, be applied in the same amount from year to year, although naturally to different individual bridges. The set of optimal repair actions and the amounts of each, i.e. the optimal repair action distribution, will keep the bridge stock in the optimal condition distribution perpetually.

#### 2.2.2 The Network Level Short Term Analysis

The short term analysis provides an economically optimal way to reach the long term optimum condition distribution during the next few years. There are separate short term solutions for each coming year. Each short term solution represent a step closer to the long term optimum.

#### 2.2.3 Features of the Network Level System

In reality the long term optimum will change somewhat from year to year because of changes in the variables that influence it. Changes can be expected in repair method costs because of new repair methods and materials. The road policy could change and level of service standards with it. New improved deterioration modelling could affect the optimum, etc.

The network level system offers the possibility for what-if experiments with respect to the safety and minimum service level policy, repair action costs, budget limits and other variables. The system will also provide detailed information for future bridge designers on the deterioration mechanisms of bridge elements and on the life-span cost of different bridge types.

### 2.3 The Project Level System

The project level system, which deals primarily with individual bridges, uses the results from the network level system to decide on the repair actions in individual repair projects. The project level system is the key tool for everyday bridge repair planning in the road districts.

The project level system is an interactive computer program that helps the bridge engineer to plan and schedule the repair projects for individual bridges based on the recommendations from the short term model and the damage data in the database.

### 3. MATHEMATICAL APPROACH

The purpose of the system is to minimize total yearly bridge repair costs under given restrictions by doing the right repair at the right moment in the lifespan of bridge components.

The mathematical solution uses a set of probabilistic Markov chain models to predict deterioration of the various structural members of the bridges in the bridge stock. The Markov state space is three-dimensional with one dimension each for structural, surface and corrosion damages. Together with data on possible repair actions for each kind of damage, the respective cost of these actions, minimum bridge condition requirements, and budget limits, linear programming (LP) models can be formulated and solved by computer to yield a recommended long-term optimal solution for the condition state distribution of





the bridge stock. The LP models also give the distribution of repair actions required each year to maintain the optimal cheapest state from year to year.

The short term model uses a modified method to recommend repair actions for several consecutive years starting with the present, to move the current distribution of condition states in the bridge stock towards the long-term ideal situation, minimizing cost along the way.

The optimizing long- and short-term models will be used to study different repair strategies and to support budget allocation decisions on both national and district level. In addition, the results are a key input to the project level system.

#### 4. BRIDGE DETERIORATION AND AGE BEHAVIOUR MODELLING

The modelling of bridge deterioration speed and age behaviour is based on the information of damages gathered during the inspections. Because there still is a lack of information of this kind, opinion surveys (Delphi studies) or expert evaluations are also made for getting the first age behaviour curves and models. When more deterioration data becomes available the models can be refined.

These models for predicting the future behaviour of bridge structures and structural members are mathematically based on the Markov chain method as mentioned above. The Markovian condition state transition probability matrixes are calculated using deterministic deterioration models based on data obtained from inspections and actual measurements or on the expert judgment elicited through Delphi studies.

#### 5. THE IMPLEMENTATION OF THE BMS

One requirement in the implementation of the BMS has been that it can be run on an ordinary IBM-compatible personal computer given enough memory and disk space. The central part of the system, the bridge database, has been implemented as a single-user relational database system with readily available software (Oracle 5.1B) and has a customized user interface. Parts of the system are in the C programming language. The bridge register has been in production use since the spring of 1990. A multiuser version of the system is planned for the central administration and for districts willing to invest in some additional hard- and software.

## Bridge Management System for the New York State Thruway Authority

Système de gestion des ponts pour l'Etat de New York

Brückenverwaltungssystem für den Staat Neu York

**Ramesh MEHTA**  
Director  
NY State Thruway Auth.  
Albany, NY, USA

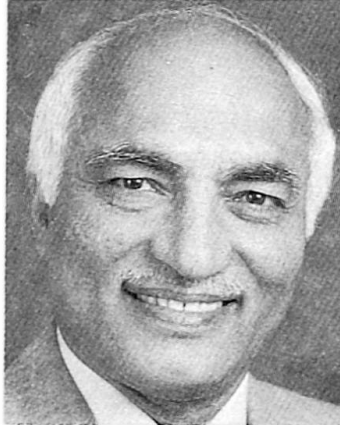

Ramesh Mehta is a registered Professional Engineer in the State of New York and is responsible for managing the Authority's program of inspection, maintenance, and rehabilitation of bridges. Previously, he worked for the Indian Railways and also served as Bridge Maintenance Expert on the Asian Development Bank's project in the Philippines.

**Richard GARRABRANT**  
Senior Eng.  
NY State Thruway Auth.  
Albany, NY, USA

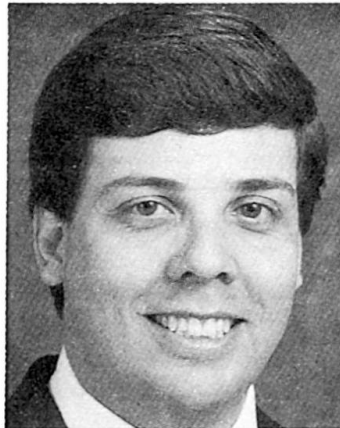

Richard Garrabrant is a registered Professional Engineer in the State of New York. A Senior Soils Engineer for the Thruway, he also directs the development of all computer applications for the Bridge and Pavement Management Systems of the Authority.

### SUMMARY

A Bridge Management System (BMS) for the New York State Thruway Authority (Authority) is being developed through a joint research effort between the Authority and Rensselaer Polytechnic Institute (RPI), Troy, New York. This paper discusses the development of the BMS Plan, BMS development tasks, and implementation issues. The term BMS is used to describe a computerized decision-aiding system incorporating both expert knowledge of bridge deterioration processes and effectiveness of management activities. Economic models of life-cycle costs are included in a process designed to provide a predefined level of service to the travelling public at a minimum cost. The BMS should assist in the optimization of available resources.

### RÉSUMÉ

Un système de gestion de la maintenance des ponts (BMS), à l'intention de l'Administration des voies express de l'Etat de New York (Administration), est en cours de développement et résulte d'un effort de recherche conjugué entre cette Administration et le Rensselaer Polytechnic Institute (RPI), Troy, New York. Le présent article examine le développement du plan BMS, les tâches impliquées et les problèmes soulevés par la réalisation de ce développement. Le terme BMS définit un système d'aide à la décision assisté par ordinateur, qui implique des spécialistes connaissant d'une part les processus de détérioration des ponts et, d'autre part, la gestion efficace des affaires. Des modèles de coûts d'exploitation et de maintien économiques sont inclus dans un procédé destiné à fournir un service prédéfini à coût minimal pour le passage public. Le BMS doit pouvoir servir à optimiser les ressources disponibles.

### ZUSAMMENFASSUNG

In Zusammenarbeit mit dem "Rensselaer Polytechnic Institute" in Troy, NY entwickelt die "New York State Thruway Authority" ein Brückenverwaltungssystem. Beschrieben werden die Entwicklung des Vorhabens, seine Ziele und Fragen der Implementierung. Das System soll als computerisierte Entscheidungshilfe sowohl Expertenwissen über den Alterungsvorgang enthalten, als auch die Brückenverwaltung effizient gestalten. Durch ökonomische Modelle der Lebenszykluskosten soll den Verkehrsteilnehmern ein im voraus festgelegter Unterhaltungsstandard zu einem Minimum an Kosten geboten werden. Es dient damit dem optimalen Einsatz vorhandener Mittel.



## 1.0 BACKGROUND

1.1 The Governor Thomas E. Dewey Thruway, commonly referred to as the New York State Thruway, is the longest toll road in the United States. It is a 570-mile long superhighway which serves as a main corridor of New York State and makes direct connections with other States major highway networks. An independent public benefit corporation, the New York State Thruway Authority (Authority) is separate from the New York State Department of Transportation (NYSDOT) in both its management and funding. The inventory of Thruway bridges includes 858 structures classified into 24 different types. The most common bridge type is the "composite I beam" simply supported structure which comprises 65% of all Thruway bridges. Other types include built-up girders, continuous I-beams, trusses, box culverts, concrete frames, and concrete arches. Span lengths vary from 20 feet for an ordinary box culvert to 1212 feet for the main truss span of the three mile long Tappan Zee Bridge which traverses the Hudson River. Other major structures include the one mile long Castleton-on-Hudson bridge, two, twin Grand Island bridges near Niagara Falls, and the 1.3 mile long viaduct in the Niagara Section.

## 2.0 IMPETUS FOR DEVELOPMENT

2.1 The majority of the toll highway system was constructed and opened to traffic between 1954 and 1960. The original construction of most structures utilized non-air-entrained concrete and non-waterproof bridge joints. These construction features in combination with intensive snow and ice control procedures utilizing chemical de-icing agents and an increasing traffic loading have resulted in a deteriorating bridge infrastructure. The goal of the BMS under development is to enhance the Authority's decision making capability through a programmatic approach to selecting and implementing bridge projects. Special emphasis is placed on preventive maintenance which will help to avert or delay the excessive deterioration of bridges through planned actions that are less involved than major rehabilitation or reconstruction.

## 3.0 APPROACH

3.1 A detailed evaluation of the Authority's bridge program was conducted over a two year period while developing the BMS Plan. Interviews at all levels of the Bridge Program were conducted starting with the Executive Director, Chief Engineers, Bridge Maintenance Engineers, and all supervisory personnel engaged in bridge inspection, maintenance, design, and construction. Emphasis during the evaluation was placed on the maintenance planning and implementation process, a review of products currently used to support the decision making process, and the needs of the bridge program.

3.2 The Plan for the development and implementation of the BMS [1] was prepared in a cooperative effort with faculty and staff from Rensselaer Polytechnic Institute and personnel at the Authority involved with the bridge program. The BMS Plan provided a description of the various components, functions, and organizational framework of the Authority's BMS.

## 4.0 MAJOR TASKS

4.1 The development of the BMS is divided into the four major tasks described below:



#### 4.1.1 Part 1 Macro-Analysis of Bridge Condition and Needs

This part involves reviewing and evaluating the present bridge conditions and needs from the system level perspective. It will utilize 13 years of bridge condition ratings generated from the existing biennial bridge inspection program, historical maintenance information, and experience. It will establish causes and costs of deterioration and bridge needs. The findings of this part are useful for possible adjustments in the current bridge program.

#### 4.1.2 Part 2 - Development of a Bridge Database

This part involves developing a comprehensive database management system capable of supporting the specific needs of the BMS, maintaining compatibility requirements with the NYSDOT, and integrating BMS with the existing Pavement Management System (PMS). The ORACLE relational database management system tool will be utilized to achieve the BMS database implementation and the interfaces between the respective systems. Existing databases located within the Authority will be enhanced and restructured to allow expanded data analysis not currently available.

#### 4.1.3 Part 3 - Development of Decision Methodologies

This part involves the development of decision methodologies required to achieve the BMS goals at the project and system levels. At the project level, methodologies will focus on each element to predict service lives, evaluate life-cycle costs of treatment options, and establish maintenance plans. Methodologies will be developed to provide a span-by-span description of conditions and needs that will facilitate development of a detailed maintenance program (e.g., Scope of Work, schedules, resources, etc.). At the system level, the methodologies will enable project selection, establishment of priorities and forecasting of future conditions and needs. The selection of a treatment option that is the best fit from not only the project basis but also from the system level basis is a very involved analysis.

#### 4.1.4 Part 4 - Program Development and Monitoring

This part involves the development and monitoring of the bridge program. It will provide the procedures and documentation required for planning and implementing the bridge program, provide a mechanism for program control and on-line progress monitoring. Additionally, it will be possible to evaluate the effectiveness of the maintenance program.

Major functions and the functional framework of the BMS are shown in figures 1 and 2.

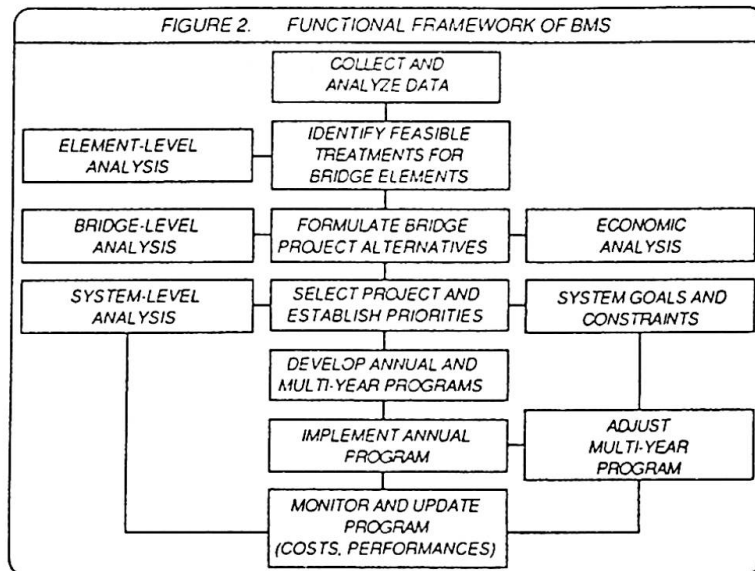
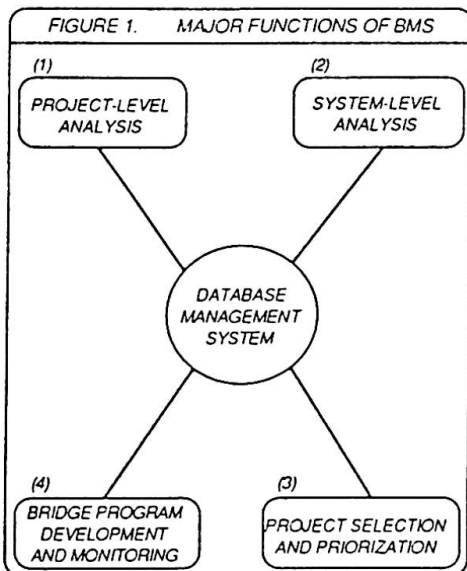



## 5.0 ENHANCEMENTS TO EXISTING BRIDGE PROGRAM BY THE BMS

5.1 The principal goal of the Authority's bridge program is to ensure the safety and serviceability of Thruway bridges in the most cost-effective manner through bridge inspection, planning, maintenance, design, rehabilitation, and reconstruction.

5.2 Major aspects of the bridge program which will be enhanced by BMS are described below:

### 5.2.1 Bridge Inventory and Inspection System

Additional guidelines will supplement the current bridge inspection techniques in order to clearly identify the relations between inspector's ratings and distress features on bridge elements and to better interpret condition ratings and develop maintenance needs.

### 5.2.2 Data Collection, Analysis, and Management

Selective data will be collected to enable a comprehensive analysis of the condition and assess needs of Thruway bridges. Data entities and their relationships will be structured in an efficient and easy to use manner, and a state-of-the-art database management system will be developed to facilitate data operations and interface with other databases.

### 5.2.3 Project-Level Analysis

Predictions of deterioration and remaining service lives of major bridge components will be determined and evaluated. Maintenance, rehabilitation, and reconstruction alternatives will be formulated for each bridge element and for each bridge as a whole and their cost analysis performed.

### 5.2.4 System-Level Analysis

Methodologies will be used to forecast deterioration and future condition of bridges, analyze short and long-term maintenance and capital (rehabilitation and reconstruction) needs, select the most cost-effective mix of maintenance and capital projects, prioritize projects (based on life-cycle costs), and establish a system wide perspective to project-level analysis.

### 5.2.5 Maintenance Planning, Monitoring, and Control

Based on established needs, plans of the annual and multi-year maintenance programs will identify preventive and corrective maintenance activities (together with their scope, required resources, schedule and frequency of application), and will provide real-time monitoring and control of the program. Furthermore, it will avail up-to-date and complete information needed for individual bridge related planning activities and will assist in historical effectiveness.

### 5.2.6 Support to Engineering Services Department

It will enhance the current load rating technique, structural and functional capacity evaluations, identify pertinent design concepts, and support the overall bridge design, rehabilitation, and reconstruction function.

### 5.2.7 Integration with PMS and Interface with NYSDOT

It will integrate BMS with the Authority's PMS to phase bridge projects along with highway projects to affect savings on traffic control etc. It will provide an interface with NYSDOT for a continuous exchange of information with a centralized database pertaining to the bridge inventory, inspection, load rating, and other bridge related issues.





### 5.2.8 Staged Implementation with Early Products

The development of BMS will take place in accordance with a phased plan which emphasizes an early introduction of products in the Authority's operation. It will evaluate historical data on the condition of Thruway bridges, susceptibility to scour and other identified vulnerabilities such as fatigue cracking, fracture critical members, seismic hazards, ship collisions etc. Past maintenance and rehabilitation practices and specific characteristics pertaining to design, construction, materials etc. used for Thruway bridges will also be evaluated.

## 6.0 BRIDGE INVENTORY AND INSPECTION DATA

6.1 Three major types of data are required to implement a comprehensive BMS: bridge inventory, inspection and load rating data; improvement activity data; and cost data related to maintenance, rehabilitation and reconstruction. The primary database containing such data as the bridge inventory, inspection, and load rating already exists in the Authority.

6.2 The condition of each Thruway Bridge is currently assessed through the Bridge Inspection Program involving biennial inspections of all structures. Elements of each bridge are rated in accordance with procedures described in the Bridge Inspection Manual developed by NYSDOT [2], a modification of the manual developed by the Federal Highway Administration (FHWA). Each bridge element is rated on a numerical rating scale of 1 to 7 by the Bridge Inspector. A rating of 1 represents a potential hazardous condition and 7 of new condition. The condition of a bridge as a whole is also assessed by the inspector on a numerical scale of 1 to 7 with 1 representing very poor condition and 7 as good condition.

6.3 The condition rating of each bridge is computed as the weighted average of the ratings received by the various elements of a bridge considered most important for its unrestricted use. These elements are assigned weights in proportion to their importance to the bridge. Principal structural elements include: primary members, abutments, piers, and the structural deck all of which have high weightage.

6.4 Presently, condition ratings are used in the initial screening for bridge project selections. However, the condition ratings sometimes provide misleading information especially in the case of multi-span bridges. A possible result of the misleading rating is the assignment of resources on an inappropriate structure. A condition assessment for each span is needed to assist in the identification of the span with the lowest condition rating and to identify the low structure condition assessment of various elements in the span. This approach will provide a logical method for the identification of problem areas and the proper assessment of bridge needs.

## 7.0 DETERIORATION MODELS

7.1 Deterioration models for individual bridge components, spans, and each bridge as a whole will be developed. These models will be based on the inspection ratings captured since the inception of the inspection program in 1978 and information on bridge maintenance and rehabilitation. It will be difficult to develop deterioration models due to the lack of inspection ratings prior to 1978 and the lack of clear and definitive maintenance records for each structure. Stochastics or probabilistic regression models will be utilized to analyze and represent the bridge deterioration process. A non-linear deterioration model developed by West et al [3] appears to be a good effort in



predicting future conditions.

## 8.0 LIFE-CYCLE COSTS MODELS

8.1 The evaluation of alternative treatments for each bridge will include not only the first or initial cost but also periodic maintenance costs and possibly the rehabilitation or reconstruction cost required as the bridge approaches the end of its service life. Treatment alternatives for bridges have unequal life expectancy, level of service, and maintenance costs, and it is appropriate to include maintenance costs in the life span of each structure.

8.2 The development of life-cycle cost models requires a strong understanding of the behavior and life expectancy of various materials used in the structure and the effects of various maintenance practices. A typical example is a concrete deck supported on steel or pre-stressed concrete girders which are subject to de-icing chemicals in the process of snow and ice control operations. These de-icing chemicals provide a safer traveling surface for the motorists yet have adverse effects on the concrete deck and also on the steel or pre-stressed girders. The importance of washing the superstructure is being advocated at present and the frequency at which this task should be performed to negate the effects of the de-icing chemicals has to be determined. The cost of deterioration induced by not washing the superstructure has also to be evaluated. These aspects of bridge maintenance practices and their associated cost will be considered in developing life-cycle cost models, a major component of the BMS.

8.3 The Authority has comprehensive Bridge Maintenance Guidelines which direct the maintenance of bridges through the use of Demand, Preventive, Corrective Maintenance and Bridge Rehabilitation. These guidelines also list preventive maintenance tasks which have to be performed on cyclic and non-cyclic (need based) basis. The frequencies for various cyclic preventive maintenance tasks have been fixed empirically and the cost-effectiveness of these tasks have to be evaluated. The BMS will assess and adjust the recommended frequencies of all bridge maintenance tasks to ensure the safe and cost effective operation of Thruway bridges.

## 9.0 CONCLUSIONS

9.1 The BMS when completed will provide an organized method for entering, retrieving, and analyzing information about Thruway bridges. It will provide needed engineering and economic analysis methodologies for evaluating, selecting, and optimizing the allocation of available resources. The BMS will support the entire range of decisions associated with the preservation of the Authority's bridge infrastructure.

## REFERENCES

1. D. A. GRIVAS. Development of a Bridge Management System: Phase 1: The Plan. Department of Civil Engineering Report, Rensselaer Polytechnic Institute, Troy, New York, November 1990.
2. NEW YORK STATE DEPARTMENT OF TRANSPORTATION. Bridge Inspection Manual-82. Bridge Inventory and Inspection System. 1982.
3. H. H. WEST, R. M. McCLURE et al. A Non-linear Deterioration Model for the Estimation of Bridge Design Life. Report No. FHWA-PA-89-016-07. The Pennsylvania Transportation Institute. 1989.

## Unterhaltungsstrategie für Düsseldorf Brücken

Maintenance Strategy for the Bridges of Dusseldorf

Stratégie de maintenance des ponts de Dusseldorf

**Fritz VOLLRATH**  
Dipl. Ing. Bauwesen  
Brückenbauamt  
Düsseldorf, Deutschland

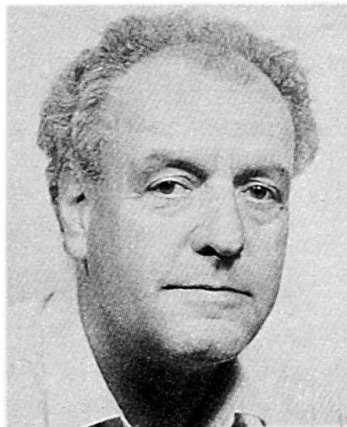

Fritz Vollrath, geboren 1934 Studium des Bauingenieurwesens an der Technischen Universität Hannover. Projektleiter von Großbauvorhaben der Deutschen Bundesbahn in Hamburg und Köln. Seit 1984 Leiter des Straßen- Brücken- und Tunnelbauamtes der Landeshauptstadt Düsseldorf mit einem Neubau- und Instandhaltungsvolumen von rd. 250 Mio DM/Jahr.

**Manfred GRASSL**  
Dipl.-Ing. Bauwesen  
Beratender Ingenieur  
Düsseldorf, Deutschland



Manfred Grassl, geboren 1940 Studium an der Technischen Universität Braunschweig, Mitinhaber des Ingenieurbüros Grassl mit Büros in Hamburg, Düsseldorf, München und Berlin. Schwerpunkt der Tätigkeiten ist der Brückenbau in Massivbau, Spannbeton und Stahl mit Entwürfen, Ausschreibungen, Statik und Brückenprüfungen.

### ZUSAMMENFASSUNG

Vorgestellt wird das System der Brückenprüfung und Brückenunterhaltung in Düsseldorf mit der exakten und detaillierten Erfassung aller Bauwerke in ein universell einsetzbares Dateiensystem. Die Ergebnisse werden in Prüfprotokolle eingetragen und in die Dateien übernommen. Mit Hilfe kann dann die Schadensbeseitigung stetig und langfristig geplant werden. Am Beispiel einer seilverspannten G.ößbrücke werden die Hauptprüfung für die schwer zugänglichen Seile (mit Hilfe eines eigens dafür entwickelten Kabelbefahrgerätes) und die anschließenden Reparaturarbeiten beschrieben.

### SUMMARY

The system of examination and maintenance of bridges in Düsseldorf with the exact and detailed recording of all the structures in an universally applicable computer-aided classification scheme is presented. The examination results are entered on record sheets and taken over in the computer scheme. The data enables the planning of the repairs on a continuous and long term basis. The paper describes, taking the example of a cable-stayed longspan bridge, the examination of not easily accessible cables and the consequent repair works with the help of a cable riding platform, specially developed for this purpose.

### RÉSUMÉ

L'article présente le système de vérification et de maintenance des ponts à Düsseldorf. Celui-ci saisit de façon exacte et détaillée toutes les constructions dans un système de fichiers universellement utilisable. Les résultats sont inscrits dans des comptes rendus de vérification et transférés dans les fichiers, à l'aide desquels on peut ainsi projeter continuellement et à long terme la réparation d'éventuels dommages. La vérification principale des haubans difficilement accessibles, conduite à l'aide d'un appareil d'inspection des haubans construit exclusivement dans ce but, et les travaux de réparation consécutifs sont décrits en prenant comme exemple un pont à haubans.





## 1. AUFGABE

Düsseldorf, eine Stadt mit knapp 600.000 Einwohnern im Westen Deutschlands, am Rhein gelegen, besitzt ungefähr 600 Brücken und andere Ingenieurbauwerke, von der kleinen Bachbrücke über die Eisenbahnbrücken bis zu Straßentunnels, einem sehr attraktiven Sportstadion und 3 großen Rheinbrücken. Diese 3 Schrägseilbrücken sind als Düsseldorfer Brückenfamilie weltbekannt. 1957 wurde das erste Mitglied dieser Familie als erste Schrägseilbrücke der Welt gebaut, die Verschiebung der Oberkasseler Brücke, des jüngsten Familienmitgliedes, erregte 1983 weltweites Aufsehen. Die Systematik der Instandhaltung dieser Bauwerke ist Thema des Vortrages. Die Arbeitsweise in Düsseldorf ist deshalb besonders interessant, weil sie wegen der großen Bandbreite der zu unterhaltenden Bauwerke und wegen der universellen Systematik als Modell für andere Baulastträger übertragbar ist.

Die Entwicklung der Brückenflächen in Düsseldorf spiegelt die wirtschaftliche Entwicklung Westeuropas wider. Im Jahre 1900 waren in Düsseldorf 8.000 m<sup>2</sup> Brückenfläche vorhanden. Diese Fläche wuchs bis zum Jahre 1950 stetig auf 12.000 m<sup>2</sup>. Das heißt, die Brückenfläche wuchs in 50 Jahren um 4.000 m<sup>2</sup>. In den folgenden 40 Jahren bis 1990 stieg die Fläche dagegen auf 400.000 m<sup>2</sup> an. Das heißt, im Mittel wurden in jedem Jahr so viele Brücken gebaut, wie es 1950 insgesamt gab. Diese Brücken haben heute einen Wiederbeschaffungswert von rd. 1.2 Mrd DM entsprechend 700 Mio. US \$. Alle diese Bauwerke müssen selbstverständlich instandgehalten werden: zum Erhalt der Verkehrswege, des Vermögens und nicht zuletzt der Sicherheit des Verkehrs. Das zunehmende Alter der Bauwerke aber auch die steigende Belastung durch Verkehrszunahmen, höhere Achslasten und Umwelteinflüsse erfordern eine Fülle von Unterhaltungsmaßnahmen.

## 2. STRATEGIE

Voraussetzung für eine organisierte Instandhaltung der Bauwerke ist die systematische Bestandserfassung. Zur wirtschaftlichen Bewältigung dieser Arbeit wurde ein ADV-Ordnungssystem erstellt. In diesem System sind alle Bauwerke mit allen Bauteilen nach Bauart, Material, Alter und Zustand erfaßt.

Die INSTANDHALTUNG besteht aus der PRÜFUNG der Bauwerke und der UNTERHALTUNG der Bauwerke. Die Prüfung der Bauwerke erfolgt in vorgegebenen Fristen entsprechend den technischen Regelwerken. In besonderen Fällen z.B. nach Hochwasser oder anderen besonderen Ereignissen werden Sonderprüfungen angeordnet. Die Regelprüfungen, die in Deutschland in unterschiedlichem Umfang nach einem, nach drei und nach sechs Jahren erforderlich sind, werden in die ADV-Systematik eingespeichert und zur rechten Zeit abgerufen. Die ADV druckt zu vorgegebenen Terminen Einzelprüfaufträge mit bauwerksspezifischen Checklisten aus, das heißt, es werden in der Liste jeweils nur die Bauteile aufgeführt, die im jeweiligen Bauwerk auch wirklich vorhanden sind. Diese präzisen Prüfaufträge steigern die Übersichtlichkeit und vermindern den Papierkrieg.

Bei der Brückenprüfung vor Ort werden alle Schäden in 4 Kategorien nach Dringlichkeit der Reparaturarbeiten klassifiziert und teilweise schon unmittelbar in einen tragbaren Computer eingegeben. Im Büro werden täglich die Prüfergebnisse in die Datei des Zentralrechners eingegeben. Anschließend werden die erforderlichen Reparaturarbeiten geplant und veranschlagt. Die Zuordnung der Kosten jeder einzelnen Unterhaltungsarbeit in der Datei ergibt den Gesamtmittelbedarf der folgenden Jahre. Die Haupttätigkeiten werden jeweils auf 5 Jahre im Voraus geplant und eingeordnet. Durch eine optimale Mischung und Abstimmung größerer und kleinerer Arbeiten sowie durch die rechtzeitige Ausführung der Reparatur- und Unterhaltungsarbeiten wird ein fast konstanter und niedriger Mittelbedarf erreicht. Die Geldgeber sind in der Regel bereit, das erforderliche Kapital zur Verfügung zu stellen, weil sie insgesamt mit niedrigen Kosten und niemals überraschend mit hohen Forderungen konfrontiert werden. Ar-

beitsaufträge für jeweils ein Haushaltsjahr werden von der ADV ausgedruckt und an die zuständigen Prüfer verteilt. Die Erledigung der Durchführung wird durch jeweilige Einzelmeldungen an die ADV kontrolliert. Damit wird sichergestellt, daß alle bei den Prüfungen entdeckten Mängel letztlich behoben werden. Außerdem ist jederzeit für jedes Bauwerk nachvollziehbar, welche Schäden auftraten und wann sie auf welche Weise mit welchen Kosten behoben wurden. Die Brückenunterhaltungsdatei wird auch ständig dazu verwendet, aus Fehlern zu lernen und bei der Planung von Neubauten stets mit an niedrige Unterhaltungskosten zu denken und die Wiederholung von Fehlern zu vermeiden.

Die Brückenprüfungen werden von Prüftrupps durchgeführt, die immer wieder dieselben Bauwerke in den vorgegebenen Fristen prüfen. Die Prüfer kennen daher "ihre" Bauwerke genau und identifizieren sich mit ihrer Aufgabe. Wirtschaftlich nicht vertretbar ist es, bei der Stadt Personal für alle Prüfarbeiten anzustellen. Die bessere Lösung liegt in der Kooperation mit speziellen Ingenieurbüros. Kleinere und konstruktiv einfache Brücken werden in der Regel vom eigenen Personal geprüft. Bei komplizierten Bauwerken ist der verantwortliche Prüfer ein Spezialist des Ingenieurbüros, der in Zusammenarbeit mit städtischen Prüfern alle erforderlichen Prüfungen durchführt. Auch hier ist eine langjährige Zusammenarbeit als Grundlage für Vertrauen, Zuverlässigkeit und Kontinuität erforderlich. Die Prüfung der Bauwerke ist eine sehr verantwortungsvolle Sache, darum ist es unerlässlich, nur entsprechend qualifizierte und erfahrene Ingenieure einzusetzen.

Die Reparaturarbeiten werden ausschließlich durch private Bauunternehmen ausgeführt. Die Leitung erfolgt durch eigenes Personal oder Ingenieurbüros entsprechend den vorausgegangenen Prüfungen. Seit 4 Jahren wird diese Instandhaltungsstrategie in Düsseldorf erfolgreich praktiziert. Die praktische Durchführung von Prüfungen wird im folgenden erläutert.

### 3. BRÜCKENPRÜFUNG

Am Beispiel der Theodor-Heuss-Brücke über den Rhein in Düsseldorf werden die Vorbereitung und Durchführung einer Brückenprüfung nach DIN 1076 durch ein Ingenieurbüro gezeigt und die daran anschließenden Arbeiten zur Instandsetzung beschrieben.

Zur Information:

Die Theodor-Heuss-Brücke ist die älteste seilverspannte Brücke in Deutschland. Fertigstellung 1957. Hauptöffnung 260 m, 4 Pylonen mit einer Höhe von 41 m über der Fahrbahn.

Der Übergang der ADV-mäßig erfaßten Bauwerks- und Schadensdatei zu dem mit der Hauptprüfung beauftragten Ingenieurbüro erfolgt nahtlos, da alle ADV-Dateien auch im Ingenieurbüro gespeichert sind. Also die beauftragte Prüfinstanz, das Ing.-Büro, hat denselben Kenntnisstand wie die Verwaltung und hat auch die vorangegangenen Prüfungen durchgeführt. Dadurch entsteht eine Kontinuität bei dem Ingenieurbüro und ermöglicht den Aufbau der Prüfgruppe mit erfahrenen Ingenieuren, der Ausstattung mit hochwertigen, für eine durchgreifende Brückenprüfung erforderlichen Instrumenten und einem über Jahre entstandenen qualifizierten Kenntnisstand über das Bauwerk. Der Brückenprüfer "lebt" somit mit dem Bauwerk und ist sich auch seiner Verantwortung bewußt.

Der Ablauf der Brückenprüfung der Rheinbrücke gliedert sich in 3 Abschnitte:  
1. Abschnitt: Vorbereitung, 2. Abschnitt: Durchführung, 3. Abschnitt: Auswertung und Schlußfolgerung

zur Vorbereitung: Alle wichtigen Daten sind aus der Bauwerksdatei, das Ergebnis der vorangegangenen Prüfung aus der Schadensdatei zu entnehmen.



Es wird das geeignete Team und die erforderliche Ausrüstung zusammengestellt:

Geräte wie Fotoapparat mit Blitzlichteinrichtung, Schichtendickenmeßgerät für Anstriche, Reißweitenlupe für Betonrisse, Prallhammer, Meß- und Führungslehren, Spiegel, Thermometer und Endoskop stehen zur Verfügung. Endoskope werden für schwer zugängliche Bauglieder wie Verankerungen von Zugpendel und im Fall der Rheinbrücke die Kabel, Kabelsattel und Verankerungen benötigt. Die Prüfer sind mit Lap-Top-Computern ausgerüstet, um die Befunde direkt in gespeicherte Protokolle einzugeben, und um Veränderungen zur vorangegangenen Prüfung unmittelbar zu erkennen.

Wesentlich ist die Überlegung der Zugänglichkeit und die Minimierung der Verkehrsbehinderung.

Zur Durchführung: Die Prüfung einer Stahlbrücke beginnt grundsätzlich mit der äußeren Beurteilung der Deckbeschichtung auf Verwitterung, mechanische Beschädigung, Abplatzungen, Korrosionsbefall mit Klassifizierung in Rostgradstufen, die in einer DIN-Norm geregelt sind.

Weiter werden sämtliche Niet- und Schraubenverbindungen und die Schweißnähte geprüft.

Aus der Vorbereitung kennt der Prüfer die Schweißnähte, die zur Reißbildung neigen. Wenn ein Verdacht auf Reißbildung besteht, wird mit geeigneten Mitteln eine Reißuntersuchung durchgeführt. Darauf will ich aber hier nicht im Einzelnen eingehen.

Die Prüfung der Konstruktion erfolgt durchgreifend. Es genügt nicht nur Stichproben durchzuführen. Zu einer Brückenprüfung gehört selbstverständlich auch die Prüfung der Brückenausbauten wie: Lager, Fahrbahnübergänge, Belag und Kappen, Geländer, abweisende Schutzeinrichtungen, Entwässerung ganz wichtig gegebenenfalls Lärmschutzeinrichtungen, Brückenbeleuchtung, Beschilderung und Verkehrslenkungseinrichtungen und schließlich müssen auch die Besichtigungseinrichtungen und die Zugänge angesehen werden. Die Prüfung der Unterbauten, Pfeiler und Gründung will ich hier nur erwähnen.

Das bisher Berichtete ist bei guter Organisation beherrschbar. Ein Problem bilden die Brückenseile. Im Düsseldorfer Stadtgebiet existieren 3 seilverspannte Rheinbrücken, die bezüglich ihrer Überspannung gleichen Konstruktionsmerkmalen unterliegen.

- Pylonhöhen zwischen 41 m und 100 m über der Fahrbahn.
- Patentverschlossene Seile zu Kabeln zusammengefaßt liegen in vertikalen Ebenen. Bei der hier vorgestellten Brücke sind es 4 Ebenen.
- Die Einzeldrähte sind unverzinkt. Bei den zwei jüngeren Brücken sind lediglich die äußeren Drahtlagen feuerverzinkt.
- Die Kabel laufen über Sattellager.
- Im Versteifungsträger werden die Seile mit einer Umlenkschelle gespreizt und einzeln verankert.
- Die Kabel sind in den oberen Zwickeln zwischen den Seilen verkittet.

Bei der Prüfung heißt es nun zwei wesentliche Probleme zu lösen:

Zunächst die Kabel zugänglich zu machen bei Pylonhöhen bis zu 100 m und dann den Zustand der Seile im Inneren der Kabel zu überprüfen.

Oberstes Gebot für die Besichtigung der Tragseile der Düsseldorfer Rheinbrücken ist, den Verkehr nicht zu behindern. Die Sperrung nur einer Spur der 3 Rheinbrücken führt zu weit in die Region reichenden Verkehrsstaus.

Bis 1986 wurden die Seile bei der Prüfung von der Fahrbahn und von den Pylonen aus mit dem Fernglas visuell besichtigt. Eine direkte Kontrolle der Kabel, die aber zwingend erforderlich ist, erfolgte wegen der Unzugänglichkeit nicht. Die grundsätzlichen Möglichkeiten, nämlich der Einrüstung der Seilebenen mit hohen Kosten und mit starker Beeinträchtigung des Verkehrs, dem Steigereinsatz, bei den erforderlichen Höhen nicht mehr möglich und einem Besichtigungsgerät mit gesondertem Tragseil werden in Düsseldorf nicht angewendet. Vielmehr wurde ein Kabelbefahrgerät entwickelt, das von den Kosten die günstigste Möglichkeit bietet und so angeordnet wird, daß keine Verkehrsbehinderung entsteht.

Das Gerät wurde so entwickelt, daß die Brückenkabel als Tragseil verwendet werden können. Es besteht aus einem Wagen, der nur auf dem obersten Brückenkabel fährt und 2 daran angehängten Arbeitsbühnen. Im Normalfall fährt dieses Gerät nur einmal das Seil bis zum Pylon und zurück zum Brückendeck (Berg- und Talfahrt). Die Versorgung der 3 Bühnen erfolgt vom Brückendeck über die Hängebühnen. Die darunter liegenden Kabel (Harfe oder Büschel) können ohne direktes Befahren besichtigt und der Anstrich von dem Wagen und von den angehängten Bühnen aus ausgebessert werden. Die Laufeinheit ist so ausgebildet, daß kein Zwang auf das Kabel ausgeübt wird. Ein Fahrwerk aus 16 schwingend gelagerten, luftbereiften Gummirädern verteilt die Lasten gleichmäßig. Seitliche Kunststoffrollen erzeugen die Seitenführung. Bewegt wird das Gerät mit einer in der Seilebene aufgestellten Winde über eine Umlenkrolle an der Pylonspitze und einem Zugseil. Als zusätzliche Sicherung ist eine Blockbremse vorgesehen, die sich selbständig auslöst und sich mit dem Brückenkabel verklemmt.

Gegenüber allen anderen Methoden Brückenseile zu besichtigen, hat das Kabelbefahrgerät folgende wesentliche Vorteile:

- Der Verkehr wird nicht behindert, da der Wagen in der Ebene der Tragseile außerhalb des Verkehrsraumes läuft.
- Es sind hohe Nutzlasten möglich, somit kann nicht nur besichtigt und geprüft werden, sondern auch alle erforderlichen Arbeiten ausgeführt werden. Im letzten Punkt des Vortrages wird gezeigt, wie nach Umbau des Wagens eine vollständige Neubeschichtung der aufgekeilten Seile vorgenommen wird.
- Von allen Möglichkeiten die kostengünstigste.

zur Auswertung und Schlußfolgerung: Im Zuge der Hauptprüfung wurde ein Kabel erstmals an mehreren Stellen aufgekeilt und mit dem Endoskop die Seile im Inneren des Kabels kontrolliert. Es zeigte sich folgender Befund: Starker Korrosionsbefall mit starker Narbenbildung, aber keine Drahtbrüche.

Es wurde folgendes Instandsetzungskonzept vorgesehen: Aufkeilen der Kabel und Anbringen von Hilfsbändselungen. Strahlen der Kabel auch im Inneren zwischen den aufgekeilten Seilen. Aufbringen der neuen Beschichtung: 2 Grundbeschichtungen und 3 Deckbeschichtungen.

Die Kabel werden im gespreizten Zustand belassen. Durch Abstandhalter alle 4 Meter aus VT-Elastomer bekommen die Einzelseile einen Abstand untereinander von ca. 20 mm. Dieses genügt, um mit dem Endoskop die Beschichtung zu überprüfen und eventuelle Drahtbrüche festzustellen. Der Abstand der Prüfungen wird verkürzt. Die in DIN 1076 vorgegebenen Fristen von 3 und 6 Jahren gehen davon aus, daß die Bauwerke keine Schäden aufweisen. Hier zeigt sich aber, daß die äußeren Drahtlagen der inneren Seile starke Narbenbildung aufweisen. Daher muß durch engeren Prüfungsabstand der Beginn von Drahtbrüchen sofort erkannt werden, um rechtzeitig Maßnahmen ergreifen zu können. Bei Dauerschwingversuchen an ausgebauten Brückenseilen an anderen Brücken ist immer ein Bruch der Seile mit Ankündigung festgestellt worden. Auch der Ausfall von beinahe der gesamten äußeren Drahtlage bewirkte kein schlagartiges Versagen. Dieses "gutmütige" Verhalten von patentverschlossenen Seilen untermauert diese Vorgehensweise. Um nun den Aufwand für Prüfungen in kürzeren Abständen möglichst niedrig zu hal-



ten, werden die Seile im aufgekeilten Zustand belassen. Ein weiterer Vorteil ist die bessere Belüftung, damit wird die Korrosionsneigung im Inneren der Kabel vermieden.

Begleitet werden die Strahl- und Korrosionsschutzarbeiten von dem Ingenieur, der die Prüfung durchgeführt hat und der auch zum Abschluß der Sanierungsarbeiten eine Aussage über den Erfolg der Maßnahmen geben muß.

Das Ergebnis der Prüfung geht in die Bauwerks- und Schadensdateien ein, wodurch auch bei der zuständigen Verwaltung der neueste Zustand der sanierten Rheinbrücke dokumentiert ist.



## Long-term Performance Monitoring of Bridges - Major Case Studies

Surveillance à long terme des ponts — étude de cas

Langzeitbeobachtungen an Brücken - Fallbeispiele

### **S.P. SHARMA**

Formerly at Structural Engr.  
Research Centre  
Ghaziabad, India

### **M.G. TAMHANKAR**

Structural Engr.  
Research Centre  
Ghaziabad, India

### **V.K. GHANEKAR**

Structural Engr.  
Research Centre  
Ghaziabad, India

### **PREM CHAND**

Structural Engr  
Research Centre  
Ghaziabad, India

### **S.P. CHAKRABARTI**

Ministry of Surface  
Transport, Govt. of India  
New Delhi, India

## **SUMMARY**

The paper presents comprehensive instrumentation schemes for three major prestressed concrete bridges under construction on the Ganga and Mandovi rivers in India. The significant parameters being monitored and the corresponding sensors and data acquisition systems are highlighted. Among the aspects covered are instrumentation for a cantilever bridge from foundation upwards and monitoring of the loss of prestress. Mathematical modelling for correlation and interpretation of the field data is also discussed. The paper concludes with considerations in developing standard instrumentation scheme for major bridges in future.

## **RÉSUMÉ**

L'article présente des méthodes de mesures exhaustives pour trois grands ponts en béton précontraint, en construction sur les fleuves Gange et Mandovi en Inde. Il explicite les paramètres essentiels faisant l'objet du contrôle, les capteurs correspondants et les systèmes de saisie des données. Entre autres aspects possibles, il donne en exemple les instruments de mesure pour un pont à porte-à-faux, répartis au dessus de la fondation, et la surveillance de la perte de précontrainte. Il examine aussi un modèle mathématique pour corrélérer et interpréter les données recueillies sur place. Il fournit en conclusion des considérations sur le développement de méthodes de mesures standard pour les grands ponts futurs.

## **ZUSAMMENFASSUNG**

Der Beitrag präsentiert umfangreiche Instrumentierungsprogramme für drei grosse indische Spannbetonbrücken über den Ganges und den Mandovi. Datenaufnehmer und -auswertungssysteme für die überwachten Schlüsselgrößen sind beschrieben. Darunter befindet sich die Instrumentierung einer Freivorbaubrücke von der Gründung aufwärts, einschliesslich der Aufzeichnung der Vorspannverluste. Desweiteren wird die mathematische Modellbindung zur Korrelation und Interpretation der Rohdaten diskutiert. Für die Zukunft wird die Entwicklung von Standardinstrumentierungen für Grossbrücken vorgeschlagen.



## 1. INTRODUCTION

A large number of major bridges are today distressed to a point where their serviceability has been severely affected and their safety called in question. Typical among the problems confronting bridge engineers today are the degradation of materials, corrosion of steel, loss of prestress, in-service performance of rehabilitated bridges, residual life, etc. These exigent issues have sharply brought home the point that the most effective way to meet this challenge is to continuously monitor the health and performance of these bridges from inception through instrumentation. Recognising this very critical need for scientific monitoring of the health of distressed/rehabilitated bridges and for creating a data base for in-service performance of major bridges, the Ministry of Surface Transport, Government of India, has recently sponsored research projects at the Structural Engineering Research Centre at Ghaziabad on three major bridges, aimed at their performance measurements and long-term monitoring through instrumentation. These studies, currently in progress, are reported in the following :

## 2. CASE STUDIES

### 2.1 Cantilever bridge on the Ganga at Varanasi

The Ganga Bridge at Varanasi, presently under construction, has several unique features. The cantilevers span 65 metres on either side of the piers. The open caisson (well) foundations are 70 metres deep, with inside and outside diameters of 8 m and 13 m, respectively.

The instrumentation scheme covers one river well (P7), one land well (P8), one pier (P7), one complete span of the superstructure (P6-P7) and the cantilever arm (P7-P8), with a view to obtain important data relating to the short-term and long-term behaviour of the bridge. The instrument data would be recorded both during construction and in service. The scheme of instrumentation covers several 'performance factors' such as actual stresses, strains, deflections, tilts, material characteristics, etc. as well as in-situ earth pressures on the wells.

#### Instrumentation of the well foundations

The parameters to be measured in the well foundations and the corresponding instrumentation techniques that have been used in a typical river well (P7) are summarised below (Fig. 1a & b):

<u>Parameter</u>	<u>Technique</u>
(i) Soil Pressure on well steining	- 18 Vibrating Wire earth pressure cells installed at three levels
(ii) Forces in well reinforcement	- 36 Vibrating Wire rebar load gauges installed in longitudinal and hoop reinforcement at three levels
(iii) Tilt of the well	Inclinometer
	- A torpedo-like sensor runs along the length of a grooved casing which is assembled in segments apace with the construction of the well to form a continuous vertical conduit through the steining. Readings provide data on the magnitude and direction of tilt of the well.
	Tiltmeter
	- A tiltmeter would be installed on the well cap to provide the data relating to the tilt of the well.



- (iv) Inspection of the inner surface of the well
- Underwater photography using a remote operated vehicle and videography, to provide evidence regarding deterioration, cracking and blemishes on the inner surface of the well
  - As a trial, the inner surface of one of the wells was scanned using an underwater camera

An even more extensive instrumentation scheme involving 48 pressure cells and 96 rebar gauges as well as the inclinometer system has been planned for a typical land well (P8) of the bridge.

Values of lateral (water/earth) pressures at different depths obtained from the pressure cells at the lowermost level as the sinking progressed are given in Fig. 2(a). The other two levels of instruments are still above the river bed and presently record water pressure only. Initial inclinometer profiles upto a depth of 30 m are shown in Fig. 2(b).

Instrumentation of the superstructure to study the short and long-term behaviour will be carried out during the construction of the bridge deck. Details of the relevant instruments/techniques are given below with reference to the next case study.

## 2.2 Bridges on Mandovi at Goa

Two bridges, under construction on the Mandovi, have double lane single cell box girders, with inclined webs in the new bridge and vertical webs in the recommissioned bridge.

The objective of instrumentation of the superstructure of the two bridges is to get an indication about the loss in prestress by instrumenting one span of each bridge. Since there is no direct practical method of knowing the level of prevailing prestress, it is proposed to monitor it indirectly by measuring as many other parameters as possible.

The various parameters to be measured and the corresponding techniques of measurement are summarised below (Fig. 1c, d & e):

<u>Parameter</u>	<u>Technique</u>
(i) Strain (at four sections)	- Embedded/Surface mounted Vibrating Wire (VW) strain gauges (36 Nos.) - Surface strains at 84 locations using 'Pfender gauge'
(ii) Temperature (at mid span)	- VW temperature gauges (16 Nos.)
(iii) Deflection	- Precision level with invar staff at 9 points - Water level indicators (18 Nos.)
(iv) Slope	- Tiltmeter measurements at 24 points would give slopes in longitudinal and transverse directions
(v) Integrity tests (Frequency and damping)	- Accelerometer, FFT Analyzer
(vi) Modulus of elasticity	- 60 specimens of concrete to be tested at different ages
(vii) Compressive strength	- 150 specimens of concrete to be tested at different ages





- (viii) Creep coefficient - 15 specimens of concrete for different permanent stress levels and incorporating strength variations
- (ix) Shrinkage coefficient - 30 specimens of concrete
- (x) Relaxation of H.T. Strand - As per standard procedure
- (xi) Friction and wobble coeff. of sheathing - Through field tests before final prestressing

Out of the 13 spans, each about 50 m long, of the New Mandovi Bridge, a typical span (P13-P14) has been selected for instrumentation. Instruments required for one span have been procured and laboratory tests are in progress.

### 3. MATHEMATICAL MODELLING

A mathematical model evolved at the design stage of a bridge does not necessarily help in assessing its behaviour or predicting its residual life. Actual data on materials and the periodically obtained values of the different parameters can be incorporated in the 'design model' to obtain a realistic model for predicting the behaviour of the bridge.

To monitor the prestress indirectly, a large number of measurements of strains, deflections, and slopes are recorded. In order to work out the total prestressing force and its average eccentricity at the section, a data reduction algorithm has been developed to compute these quantities from the longitudinal strains in concrete measured at that section. An equation relating to the prestressing force  $P$  v/s longitudinal strain  $\epsilon$  can be expressed as follows:

$$\{\epsilon\}_{m \times 1} = \frac{1}{E} [K]_{m \times 3} \{P\}_{3 \times 1} + \frac{M}{EI_x} \{y\}_{m \times 1} \dots (1)$$

where

$$\{P\}_{3 \times 1} = \begin{Bmatrix} P \\ P.e_x \\ P.e_y \end{Bmatrix}$$

and  $P$  is the total prestressing force on the section and  $e_x, e_y$  are its eccentricities.

$M, E, I_x$  = additional moments, modulus of elasticity and Moment of Inertia

$\{y\}_{m \times 1}$  =  $y$  coordinates of the section where strains are measured

In order to minimise the errors in the measurements, least square technique has been used. It will minimize the sum of squares of approximation errors at the data points. The sum of the squares of the error of equation (1) is given in the form

$$Err\{P\} = \sum_{n=1}^m \left[ \epsilon_n - \frac{1}{E} \left\{ K_{n,1}P_1 + K_{n,2}P_2 + K_{n,3}P_3 + \frac{M y_n}{I_x} \right\} \right]^2 \dots (2)$$

where  $P_1 = P, P_2 = P.e_x, P_3 = P.e_y$

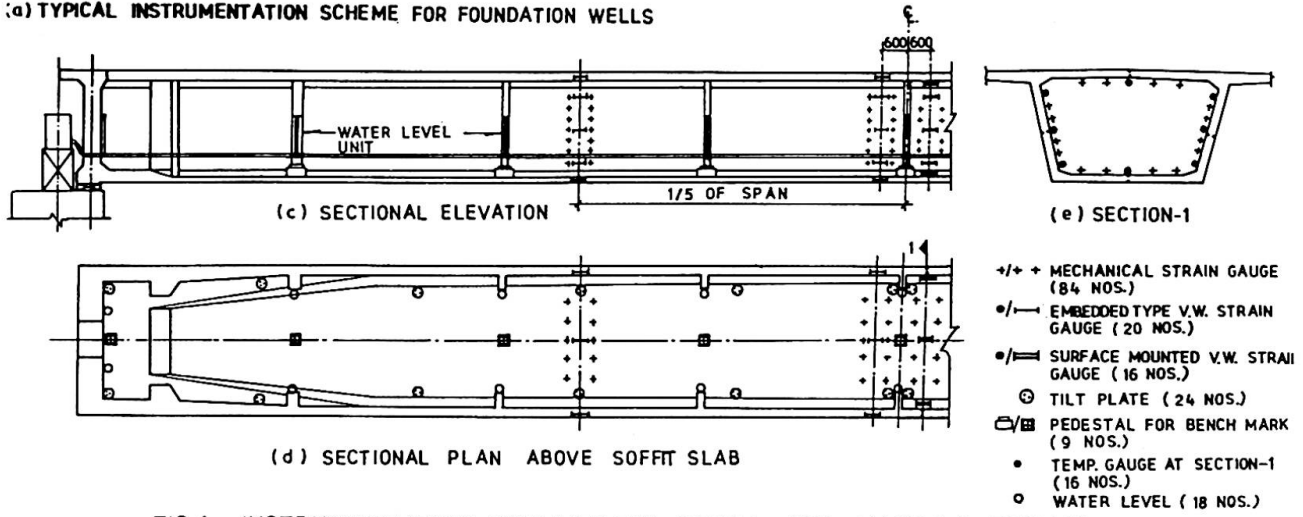
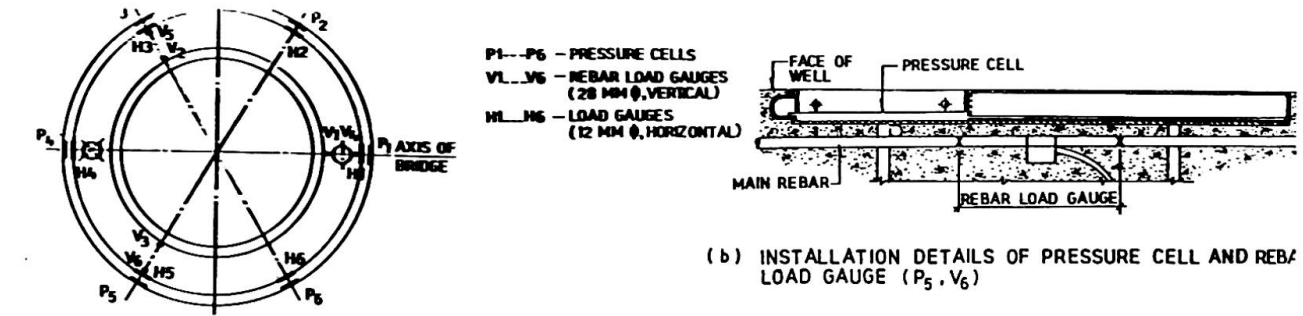

FIG.1 INSTRUMENTATION SCHEMES FOR GANGA AND MANDOVI BRIDGES

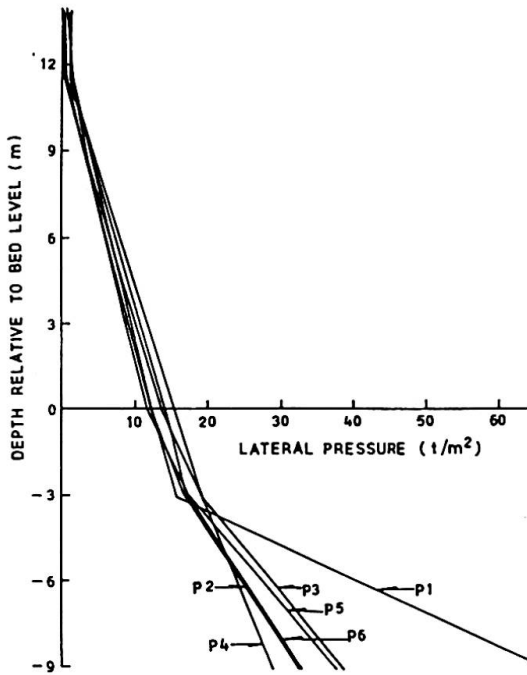

FIG. 2 (a) LATERAL PRESSURE VALUES OBTAINED FROM PRESSURE CELLS ( $t/m^2$ )

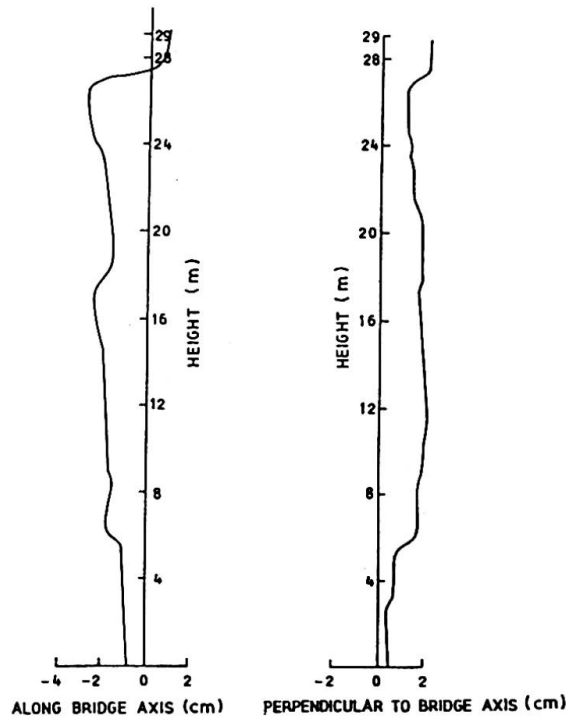

FIG. 2 (b) INITIAL PROFILE OF INCLINOMETER CASING



For errors to be minimized,  $\partial E_{rr} / \partial P = 0$  . . . (3)

On using equation (2) and (3) one gets

$$\{P\}_{3 \times 1} = E \left[ [K]_{3 \times m}^T [K]_{m \times 3} \right]^{-1} \left[ [K]_{3 \times m}^T \{\varepsilon\}_{m \times 1} - \frac{M}{EI_x} \{y\}_{m \times 1} \right] \dots (4)$$

Thus we can compute the prevailing prestressing force  $P$  and its point of action at the section under consideration. This approach will help to update the mathematical model for prestressed sections. Similarly, other algorithms required to assess/predict the behaviour would also be improved with the help of other parameters, the values of which would be generated in the field.

#### 4. CONSIDERATIONS IN INSTRUMENTATION OF BRIDGES

In planning an instrumentation scheme for a bridge several considerations must be borne in mind.

(i) Instrumentation cannot retrace the distress history, i.e. it cannot lead us to the causes which brought about the distress, but can only help us to monitor the condition of the bridge from the time the instruments were installed.

(ii) Instrumentation is not an end in itself. Correct interpretation of data acquired through instrumentation calls for realistic mathematical modelling of the structural and material behaviour.

(iii) Instrumentation on a major scale entails considerable expenditure on equipment and fieldwork, much of which is irretrievably lost within the body of the structure. The type of instruments and their quantum need therefore to be planned carefully.

(iv) All experimental work involves an element of error and instrumentation in the field even more so. Furthermore, some mortality of the instruments employed is unavoidable. Hence the utmost need for providing adequate redundancy of measurement and for making data logging as automatic as possible.

(v) Finally, it cannot be overemphasised that the human element is of crucial importance in experimentation. Success in any instrumentation effort can result only from a high degree of commitment to the effort by the individuals involved in it. None but perfectionists fill the bill.

#### 5. ACKNOWLEDGEMENT

The authors express their sincere thanks to their colleagues M/S A. Murugiah, C. Srinivas, G.K. Sahu, Gulshan Kumar and V. Swamy for their assistance in these instrumentation projects.

The paper is published with the permission of the Director, Structural Engineering Research Centre, Ghaziabad.