

Bending frequencies of HAWECS towers

Autor(en): **Gopalakrishnan, N. / Radhakrishnan, R. / Vombatkere, S.G.**

Objektyp: **Article**

Zeitschrift: **IABSE congress report = Rapport du congrès AIPC = IVBH
Kongressbericht**

Band (Jahr): **14 (1992)**

PDF erstellt am: **13.09.2024**

Persistenter Link: <https://doi.org/10.5169/seals-853165>

Nutzungsbedingungen

Die ETH-Bibliothek ist Anbieterin der digitalisierten Zeitschriften. Sie besitzt keine Urheberrechte an den Inhalten der Zeitschriften. Die Rechte liegen in der Regel bei den Herausgebern.

Die auf der Plattform e-periodica veröffentlichten Dokumente stehen für nicht-kommerzielle Zwecke in Lehre und Forschung sowie für die private Nutzung frei zur Verfügung. Einzelne Dateien oder Ausdrucke aus diesem Angebot können zusammen mit diesen Nutzungsbedingungen und den korrekten Herkunftsbezeichnungen weitergegeben werden.

Das Veröffentlichen von Bildern in Print- und Online-Publikationen ist nur mit vorheriger Genehmigung der Rechteinhaber erlaubt. Die systematische Speicherung von Teilen des elektronischen Angebots auf anderen Servern bedarf ebenfalls des schriftlichen Einverständnisses der Rechteinhaber.

Haftungsausschluss

Alle Angaben erfolgen ohne Gewähr für Vollständigkeit oder Richtigkeit. Es wird keine Haftung übernommen für Schäden durch die Verwendung von Informationen aus diesem Online-Angebot oder durch das Fehlen von Informationen. Dies gilt auch für Inhalte Dritter, die über dieses Angebot zugänglich sind.

Bending Frequencies of HAWECS Towers

Résonance à la flexion des mâts de rotors éoliens

Biegeeigenfrequenzen von Windrotor-Masten

N. GOPALAKRISHNAN

Scientist
Struct. Eng. Res. Centre
Madras, India

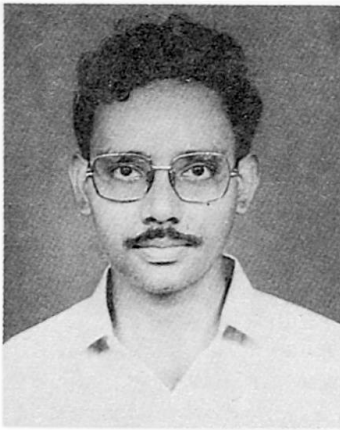

N. Gopalakrishnan received his M.Tech. in Structural Engineering from Indian Institute of Technology, Madras, in 1986. After a short stint at Tata Consulting Engineers, Bangalore, he is now working as a Scientist in Structural Engineering Research Centre, Madras.

R. RADHAKRISHNAN

Prof.
Indian Inst. of Technol.
Madras, India

Mr. R. Radhakrishnan, Professor and Head of the Dep. of Struct. Eng. at the Indian Inst. of Technology, Madras. He has guided a large number of research students and published a number of research papers. He is well-known in the areas of Structural Dynamics and Stability of Structures.

S.G. VOMBATKERE

Dr.
Indian Inst. of Technol.
Madras, India

Dr. S.G. Vombatkere, received his Ph.D in Structural Engineering from Indian Inst. of Technology, Madras, in 1987. He is a Colonel in the Indian Army. He is a Guinness world record holder for constructing the world's highest altitude bridge.

SUMMARY

A Horizontal Axis Wind Energy Conversion System is a fixed frequency operating machine. It should be designed in such a way that at least the first two natural frequencies are tuned with respect to the operating frequency. The parameters affecting the bending frequency are chosen to cover the entire range of the guyed and free-standing towers. Rayleigh's energy function for the first mode is also given in the paper.

RÉSUMÉ

Les rotors éoliens à axe horizontal, servant à la transformation d'énergie éolienne en énergie électrique, fonctionnent à vitesse constante. Il faut les concevoir de telle sorte que les deux premières fréquences naturelles de résonance de la structure porteuse soient différentes de la fréquence de résonance. Les paramètres influant sur la résonance à flexion sont choisis pour couvrir complètement la plage allant des mâts haubanés jusqu'à ceux entièrement libres, en adoptant les quotients de Rayleigh pour la première forme propre.

ZUSAMMENFASSUNG

Windrotoren mit Horizontalachse zur Stromerzeugung werden bei konstanter Drehzahl betrieben. Sie sollten so entworfen werden, dass zumindest die zwei untersten Eigenfrequenzen des Tragwerks nicht in der Nähe der Drehzahl liegen. Die für die Biegeeigenfrequenz massgebenden Parameter werden für den Bereich von abgespannten bis zu freistehenden Masten untersucht, unter Verwendung des Rayleigh-Quotienten für die erste Eigenform.



1. INTRODUCTION

The spiralling increase in the price of coal and petroleum, their depletable nature, and the pollution hazards caused thereby, make nations look for alternative sources for energy. High initial cost/KWH, high maintenance cost, and the waste disposal problems make nuclear and thermal power plants less economical in rural areas, where power consumption is relatively smaller. Wind power will provide the best solution in these circumstances with the least maintenance problem.

2. WIND ENERGY CONVERSION SYSTEM (WECS)

The principal components of a Horizontal Axis Wind Energy Conversion System (HAWECS) are the rotor, the blades and the alternator housed inside the nacelle, capable of freely yawing about a vertical axis. Nacelle is mounted on the top of the tower. The rotor imbalance and the momentary passage of the blades through the wind shadow region cause a dynamic excitation of the tower with forcing frequencies equal to $1 \times \text{RPM}$ and $N \times \text{RPM}$, respectively ($N = \text{Number of blades}$). Hence, it becomes imperative to detune the natural frequencies of a tower away from both the forcing frequencies.

A tower can either be guyed or free standing. Some of the famous guyed wind mill towers in the world are the Kuriant (15 KW) and the Jydsk VindKraft (15 KW) Wind mills in Denmark, the Sokol (15.2 KW) Wind generator in USSR and the Brummer, Bowe and Hullman (all 10 KW) wind generators in Germany. Growian I and II (3 and 5 MW) in Germany, The Volund (0.25 MW) in Denmark and the Andreau-Enfield (0.1 MW) aerogenerator in Algeria are examples of high power guyed wind power systems [1]. Guying renders a tower economical as the tower can be of smaller section. But it induces non-linearity due to the sag of the cables and also due to the reduced axial stiffness of the tower. However, in cases where the guy tension (T) is considerably more than the self weight (W) of the cable, the stiffness can be linearised by the Davenport's approximation [2].

$$k = K \left[1 + \frac{W^2 S^3 K}{12 T^3} \right] \quad \dots (1)$$

T = Average Guy Tension, W = weight/unit length of cable, S = Chord length, K = Stiffness assuming the cable as a truss member, k = Effective stiffness

The commonly used tower/guy configurations are shown in Fig.1. Fig.1(a) and Fig.1(b) are the plan views of typical guy configurations and Fig.1(c), Fig.1(d), and Fig.1(e) are the typical tower configurations used. It can be easily proved that for guy systems in Fig.1(a) and Fig.1(b), the stiffness can be given by

$$k_{11} = k_{22} = x k, \quad [x = 1.5 \text{ FOR FIG.1(a) AND } 2.0 \text{ FOR FIG.1(b)}] \quad \dots (2)$$

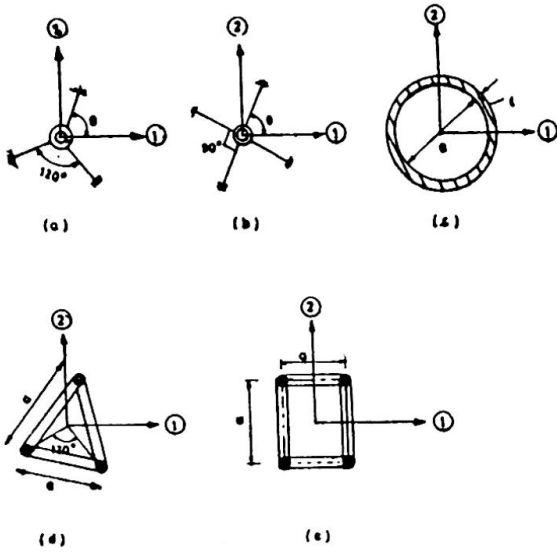

FIG-1 TYPICAL GUY/TOWER CONFIGURATIONS

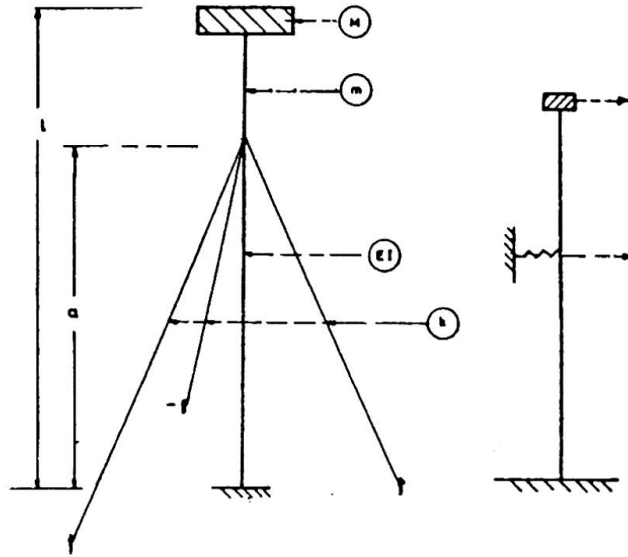

FIG-2 PARAMETERS TAKEN IN THE ANALYSIS

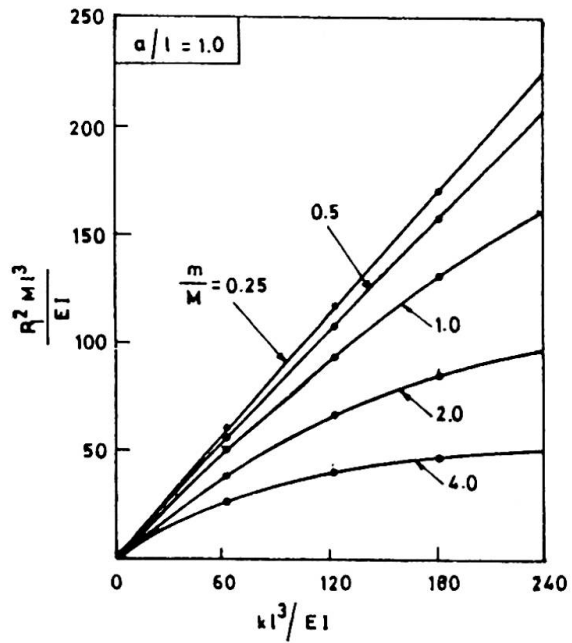
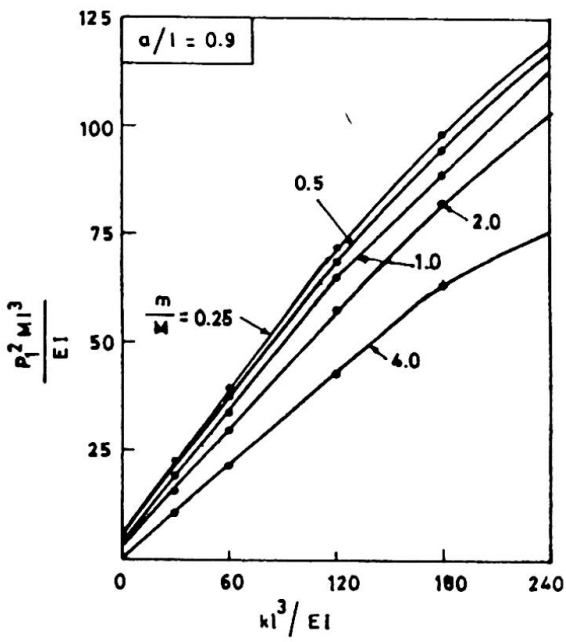

FIG-3 VARIATION OF FIRST BENDING FREQUENCY



where k_0 = stiffness of a single guy cable in plan, and
 $k_{12} = 0$

Similarly, it can be shown that for the tower sections shown, the moment of inertia is a constant value in all directions.

3. BENDING FREQUENCIES OF HAWECS TOWERS

The parameters which affect the bending frequency (p) of a guyed tower with top mass can be non-dimensionalised and grouped as follows (Fig.2).

$$p^2 M l^3 / EI = f(a/l, k l^3 / EI, m / M) \quad \dots (3)$$

m = self weight of the prismatic tower, M = top mass of nacelle, EI = Young's modulus x moment of inertia of the tower, k = Stiffness of the guys, a = level of guy attachment point, l = height of the tower, and p = frequency in rad/sec.

A parametric study has been done on Eqn.(3) to find the variation of the frequency parameters $p^2 M l^3 / EI$ against the variation on guy level parameter,

$$a/l = C_1 = 0.5, 0.6, 0.7, 0.8, 0.9 \text{ and } 1.0$$

guy stiffness parameter

$$k l^3 / EI = C_2 = 0, 30, 60, 120 \text{ and } 240 \text{ and mass parameter}$$

$$m / M = C_3 = 4, 2, 1, 0.5 \text{ and } 0.25$$

A linear eigen value solution program has been used for this purpose to generate the frequencies. The value of $p_1^2 M l^3 / EI$ have been plotted for $a/l = 0.9$ and 1.0 (Fig.3) (p_1 = first bending frequency). The second bending frequency parameter taken is $p_2^2 m l^3 / EI$ as there is less variation for this parameter when compared to $p_2^2 M l^3 / EI$. The first mode is a cantilever mode with the mode shape value, largest at the top point. Hence, top mass becomes a sensitive parameter. The second bending mode shape, however, has the largest value near the mid height, thus causing the distributed mass of the tower to be a sensitive parameter. Fig.4 shows the variation in the second bending frequency parameter.

4. RAYLEIGH'S ENERGY FUNCTIONS

There are two Rayleigh's energy functions considered for the evaluation of the first bending frequency of the HAWECS tower [3].

1. The deflection profile of a cantilever with rigidity EI and propped with a spring of stiffness k at the point of guy attachment and having a load at the tip. This worked very effectively for the range of $a/l = 0.5$ to 0.9 . Maximum deviation is found at $a/l = 0.9$, giving an error of 4% in the frequency.

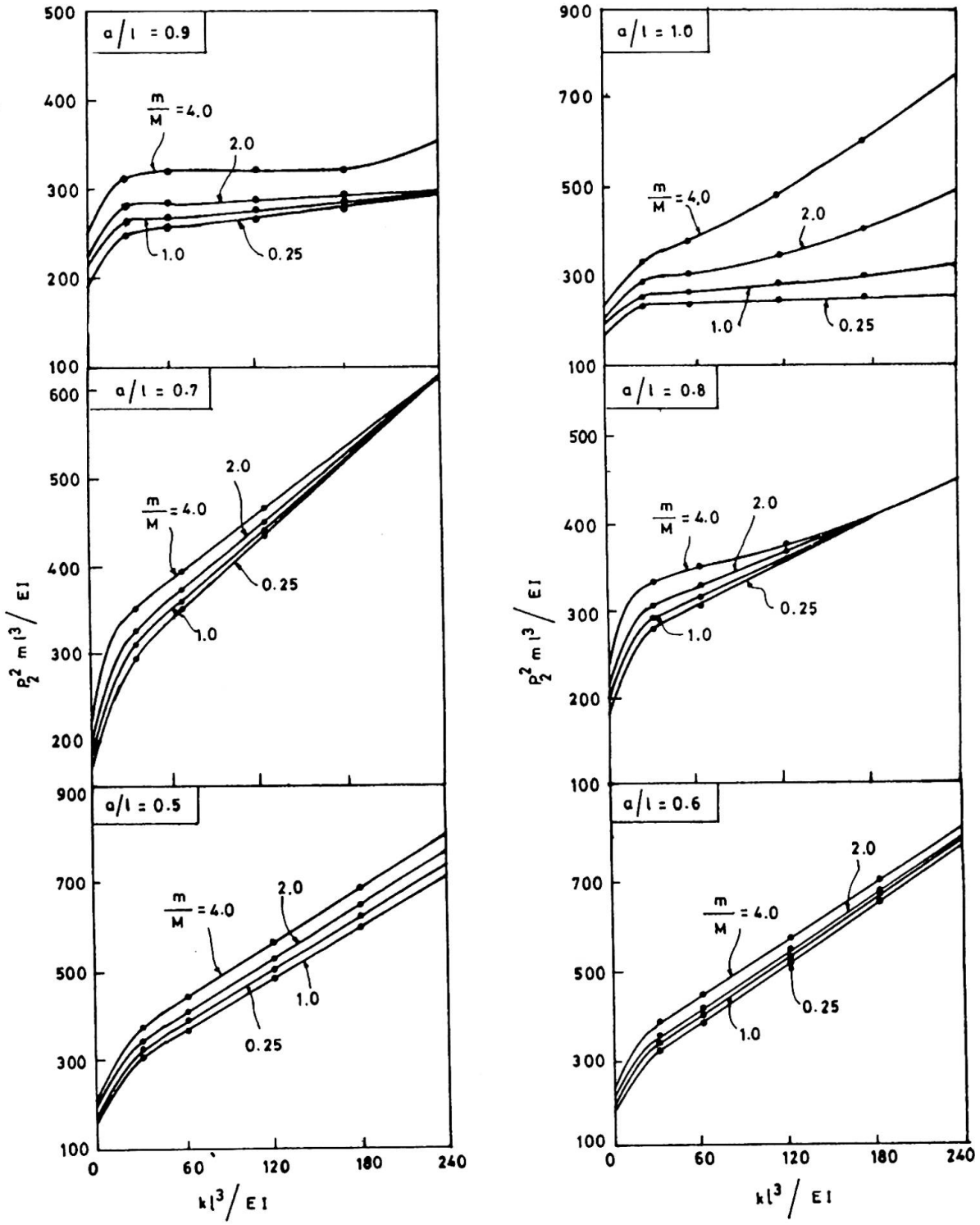

FIG-4 VARIATION OF SECOND BENDING FREQUENCY



Defining $\alpha = x/l$ x AXIS FROM FOUNDATION LEVEL

$$y = \alpha^3 (C_0 - 1) + \alpha^2 (3 - 3C_0 C_1); \quad a > x > 0$$

$$y = -\alpha^3 + 3\alpha^2 - 3C_0 C_1^2 \alpha + C_0 C_1^3; \quad l > x > a \quad \dots (4)$$

$$C_0 = C_2 (3C_1^2 - C_1^3) / (6 + 2C_2 C_1^3)$$

2. For $a/l = 1.0$, the deflection profile considered is for a cantilever of stiffness EI , propped with a spring of stiffness k at the free end and loaded with a mass proportional to M at the free end and m along the length. The resulting deflection is as follows.

$$y = 4\alpha^2 (3 - \alpha) C_0 + C_3 (\alpha^4 - 4\alpha^3 + 6\alpha^2)$$

$$C_0 = -C_2 (3C_3 + 8) / 8(3 + C_2) + 1 \quad \dots (5)$$

The frequency is got by equating the energy terms due to strain energy and kinetic energy.

$$E_1 = \int_0^l \frac{EI}{2} (y''')^2 dx + \frac{k}{2} y^2(a) \quad \dots (6)$$

$$E_2 = p^2/2 \left[\int_0^l \frac{m}{1} y^2 dx + M y(l)^2 \right]$$

$E_1 =$ Strain energy and $E_2 =$ kinetic energy

5. CONCLUSIONS

The three dimensional dynamic modelling can be replaced by a simplified model using the assumptions stated in the paper. By using Fig.3, Fig.4 and the Rayleigh functions given, it is possible to design a HAWECS tower and detune its frequencies away from the forcing frequencies. The effect of rotational inertia of the nacelle on the frequencies can be neglected.

ACKNOWLEDGEMENT

The authors gratefully acknowledge the Director, Structural Engineering Research Centre, Madras, for permitting them to publish this paper.

REFERENCES

1. GOURIERES D.Le., Wind Power Plants, Theory and Design, Pergamon Press, 1982
2. DAVENPORT, A.G., Dynamic Behaviour of Massive Guy Cables, Journal of Structural Engineering Division, ASCE, June 1965
3. GOPALAKRISHNAN, N., Free Vibration Behaviour of Guyed Towers, M.Tech. Thesis, Indian Institute of Technology, Madras, June 1986