

**Zeitschrift:** IABSE congress report = Rapport du congrès AIPC = IVBH  
Kongressbericht

**Band:** 14 (1992)

**Artikel:** Joining method for use in automated building-frame erection

**Autor:** Iwata, Mamoru / Wada, Akira / Yazaki, Mitsuhiko

**DOI:** <https://doi.org/10.5169/seals-853180>

### **Nutzungsbedingungen**

Die ETH-Bibliothek ist die Anbieterin der digitalisierten Zeitschriften. Sie besitzt keine Urheberrechte an den Zeitschriften und ist nicht verantwortlich für deren Inhalte. Die Rechte liegen in der Regel bei den Herausgebern beziehungsweise den externen Rechteinhabern. [Siehe Rechtliche Hinweise.](#)

### **Conditions d'utilisation**

L'ETH Library est le fournisseur des revues numérisées. Elle ne détient aucun droit d'auteur sur les revues et n'est pas responsable de leur contenu. En règle générale, les droits sont détenus par les éditeurs ou les détenteurs de droits externes. [Voir Informations légales.](#)

### **Terms of use**

The ETH Library is the provider of the digitised journals. It does not own any copyrights to the journals and is not responsible for their content. The rights usually lie with the publishers or the external rights holders. [See Legal notice.](#)

**Download PDF:** 15.10.2024

**ETH-Bibliothek Zürich, E-Periodica, <https://www.e-periodica.ch>**

## Joining Method for Use in Automated Building-Frame Erection

Montage automatisé pour les ossatures en portique

Automatisierte Montage von Rahmentragwerken

### **Mamoru IWATA**

Department Manager  
Nippon Steel Corporation  
Tokyo, Japan

Mamoru Iwata, born 1947, received his doctor of engineering degree at the Tokyo Institute of Technology. He is responsible for the technology development of building construction. He is a member of IABSE, AIJ, and JSCE.

### **Akira WADA**

Professor  
Tokyo Institute of Technology  
Tokyo, Japan

Akira Wada, born 1946, received his doctor of engineering degree at the Tokyo Institute of Technology. His research interest is in architectural building structures. He is a member of IABSE, AIJ, JCI, and JSCE.

### **Mitsuhiko YAZAKI**

Senior Manager  
Nippon Steel Corporation  
Tokyo, Japan

Mitsuhiko Yazaki, born 1951, received his master of engineering degree at the Tokyo Institute of Technology. He is responsible for the research and development of systematized buildings.

### **Hiroki KAWAI**

Senior Structural Engineer  
Nikken Sekkei Ltd.  
Tokyo, Japan

Hiroki Kawai, born 1938, received his master of engineering degree at the University of Waseda. He is working at Nikken Sekkei as a structural engineer. Now he is involved in the waterfront project of Tokyo bay.

### **SUMMARY**

This paper discusses a new jointing method developed as a step toward the automation of in-situ assembling of structural members at the erection stage. The use of this jointing method will not only facilitate construction automation but also make it possible to very easily remove structural members for reuse during extension, remodelling or dismantling of buildings.

### **RÉSUMÉ**

Cette étude expose une nouvelle méthode d'assemblage qui a été conçue en tant qu'étape intermédiaire vers l'automatisation d'assemblage sur places des éléments de structure pendant la phase de montage. L'utilisation de cette méthode d'assemblage facilite non seulement l'automatisation du montage, mais elle facilite aussi le démontage des éléments de structure, afin de les réemployer en cours d'agrandissement, de transformation ou de démontage des bâtiments.

### **ZUSAMMENFASSUNG**

Dieser Vortrag erörtert ein neues Gliederungsverfahren, das als eine Massnahme zur Automatisierung der Montage von Bauteilen an Ort und Stelle bei der Ausführungsstufe entwickelt wurde. Die Verwendung des Gliederungsverfahrens fördert nicht nur die Bauautomatisierung, sondern auch die sehr leichte Beseitigung der Bauteile, um sie während der Erweiterung, des Umbaus oder der Demontage von Gebäuden wiederzuverwenden.



## 1. PREFACE

Industrially advanced countries, having telecommunications technology through the use of electronics, satellites, fiber optics and other high technologies, are rapidly transforming into advanced information societies. This has helped accelerate the shift toward tertiary industries and a concentration of population in urban areas, resulting in the growth of buildings and urban facilities in both magnitude and height. Furthermore, modern urban buildings, which emerged about one hundred years ago, are on the verge of obsolescence. Yet, even at this stage, the construction industry is still unable to shake free from the restraints of conventionalism, and lags far behind other industrial sectors in productivity. With no or very little improvement foreseeable in the construction labor situation, it is becoming harder and harder for the construction industry to hire people.

In this situation, research and development primarily aimed at the improvement of productivity in construction has finally been initiated in the past several years. Specifically, R&D is addressing the introduction of new construction materials, new manufacturing and fabricating systems, construction automation, and AI in design and management. Building construction as an integrated system aided by these technologies will be a breakthrough in the present impasse in the construction industry, through the introduction of industrial efficiency.

This paper discusses a new jointing method developed as a step toward the automation of at-site assembling of structural members at the erection stage. This jointing method presupposes the automation of jointing work, as opposed to the usual practice of weld-jointing or high-tension-bolt jointing employed for steel structures.

## 2. SYSTEMATIZED BUILDING STRUCTURE

A building structure using the new jointing method is called a Systematized Building Structure (SBS). The SBS is a system for supplying general-purpose structures for medium and high-rise buildings.

Thus far, systematized building construction has been developed and utilized for housing, factory and office-building construction purposes in many fields and in many different ways. Yet, given these premises, we still propose to further address the task of developing the SBS now, for the following reasons:

- (1) The need for improvement in the construction labor situation.
- (2) Emergence of technology seeds in peripheral high technologies to facilitate and promote industrialized building construction.
- (3) The imminent need for conservation of construction materials and energy.
- (4) Social need for modernization of the construction industry and a new concept in building manufacture and construction.
- (5) The need for a system of integrating the design, manufacture, construction and maintenance of buildings, based on computerization and communications.

As a condition for organizing the SBS, the environment for construction of a building needs to be viewed within a certain hierarchy. In a sense, this hierarchization is characteristic of building construction itself. Also, in order to permit the scientific growth and development of building construction, which is an extremely complex, total system containing both metaphysical and physical problems, hierarchization is indispensable. To promote the rational progress in sophistication and self-organization in building construction, hierarchization is a very effective approach.

For the SBS we have in mind, the following hierarchy is envisaged (Fig. 1).

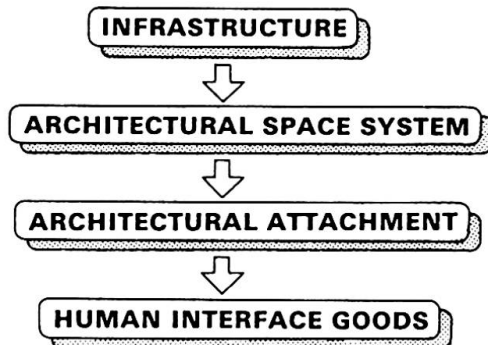

Fig. 1 Hierarchy of architecture

- (1) Infrastructure.  
Facilities which restrain an architectural space system and support economic and social activities outside the building: roads, water-purification, sewerage and energy-supply systems, and telecommunications systems.
- (2) Architectural space system.  
System to fixate architectural space: columns, beams, roofs, floors, walls, stairs and elevators.
- (3) Architectural attachment.  
Goods which do not fixate architectural space but are mounted on the architectural space system, for decoration or for improved performance of architectural space: doors, windows, curtain walls and unit equipment.

- (4) Human interface goods.  
Goods which directly interface with humans and support human life: furniture, lighting equipment, interior goods, AV equipment and other home electrification equipment.

In this hierarchy, with levels (1) to (4) in their order of predominance, the upper-level systems restrict lower-level systems according to prescribed rules. In the architectural space system, the SBS represents the structure.

### 3. PERFORMANCE REQUIREMENTS OF THE SBS

The required performance of the SBS is prescribed by infrastructure, which is the upper system, and by the SBS's consistency with the architectural space system as a whole, as well as by interfacing with architectural attachment. The SBS's performance is also prescribed by integrated computer control exercised over the design, manufacture, execution and maintenance or the so-called CIM (computer integrated manufacturing), which integrates CAD, CAM, CAC (computer aided construction), and CAP (computer aided planning).

In concrete terms, the SBS's performance requirements are conceived to be as follows:

- (1) To conserve energy and resources, structural components of the SBS must have long durability.
- (2) The whole architectural space system containing the SBS must be a system with sufficient flexibility vis-a-vis changes in space characteristics to match changes in functions and uses.
- (3) In order to clearly define the structural performance of the SBS, the strength, jointing performance and deformation capacity of individual structural components of the SBS must each be clearly defined and prescribed for high structural integrity.
- (4) To assure the long-time use of the SBS in terms of structural members, components must be standardized and possess interchangeability with respect to performance.
- (5) In consideration of the construction phase of the SBS, the SBS must be amenable to automation at the site.



With respect to jointing and modules, consistency of the SBS with the architectural space system as a whole is established. In other words:

- (1) The SBS is made to be suppliable separately from the architectural attachment of a lower hierarchical level by setting rules for mutual compliance by both the architectural space system as a whole and the architectural attachment.
- (2) The SBS consists of four structural elements: namely, floor, wall, column and beam.
- (3) The SBS's four structural elements each consist of members and components.
- (4) Members have configurations suited for automatic assembling at the site, with corresponding jointing methods.
- (5) Individual components are conceived as being primarily prescribed by configuration and structural characteristics and being functional in their performance when placed in any position of any building. In this respect, individual components are rendered characterless.
- (6) Material of components, despite being steel, has outstanding heat resistance and atmospheric corrosion resistance.
- (7) Components are manufactured by the production system designed for highly advanced machine work.
- (8) A systems approach is used for the SBS, taking into consideration every technological possibility and consistency at each level involving the whole structure, structural elements, members, components, and materials (Fig. 2). Also sought is structural rationality in the total flow of construction, from the design, manufacture, assembly and erection to maintenance.

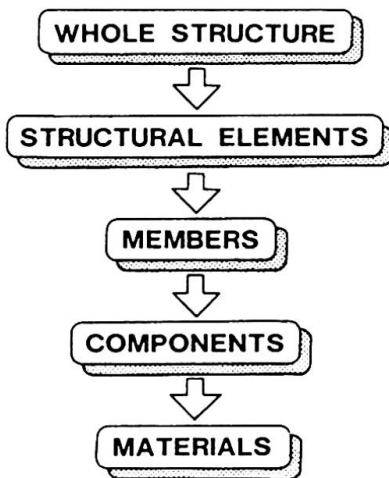

Fig. 2 Hierarchy of structure

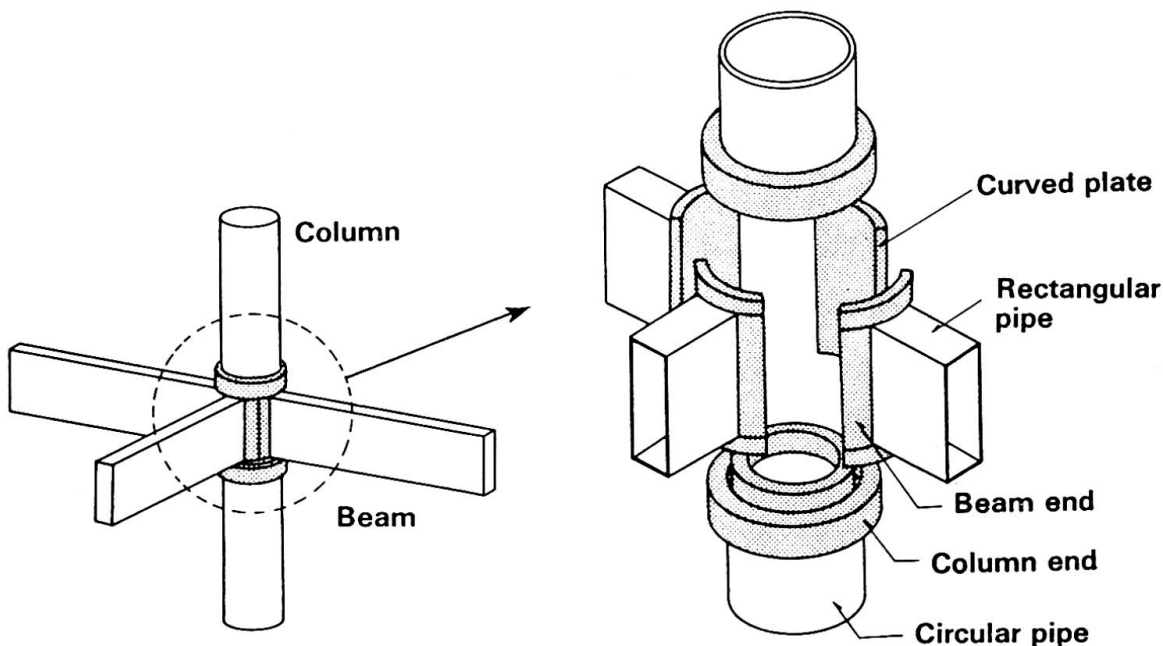

Fig. 3 Column-to-beam joint

#### 4. A NEW JOINTING METHOD FOR THE SBS

The SBS at the present stage looks like a traditional Japanese timber structure. This SBS is a prefabricated structural system consisting of a column and beam, and uses a new jointing method instead of a conventional bolting or welding connection.

A column-to-beam joint is shown in Fig. 3. This is a rigid joint.

- (1) A column member is made by factory-welding a grooved ring, called the column end, to each end of a circular pipe.
- (2) A beam member is made by factory-welding a quartered cylindrical segment tapered at the top and bottom, called the beam end, to each end of a rectangular pipe.
- (3) At the site, the beam ends are inserted into the groove of the column end. The pressing down of the column end of the subsequent story column fixes the beam ends.
- (4) In the directions where there are no beams, quartered cylindrical segments tapered at the top and bottom, called the curved plate, are inserted.
- (5) In order to secure structural integrity of the joint, the column ends are further tightened using hydraulic jacks.

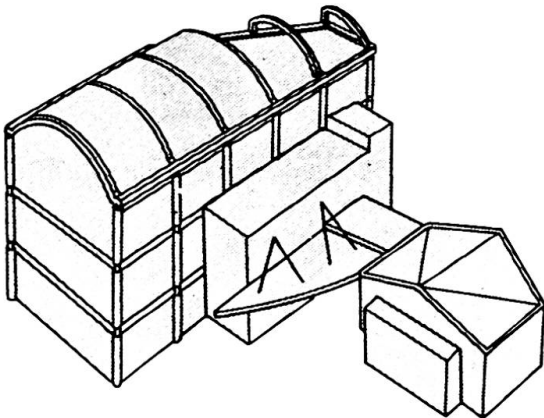

Fig. 4 An example of construction

These ingenious devices are designed to transfer axial forces, bending moment and shearing force at the column-to-beam joints. Column ends, beam ends and curved plates are forged and machined for greater dimensional accuracy.

#### 5. AN EXAMPLE OF CONSTRUCTION

The new jointing method has been applied to the actual construction of a building having three stories and one basement, with a span of 7.8m and a ridge span of 18m (3.6m x 5m span), as shown in Fig. 4.

Installation and jointing are shown in Figs. 5 and 6.

Fig. 7 shows the whole structure.

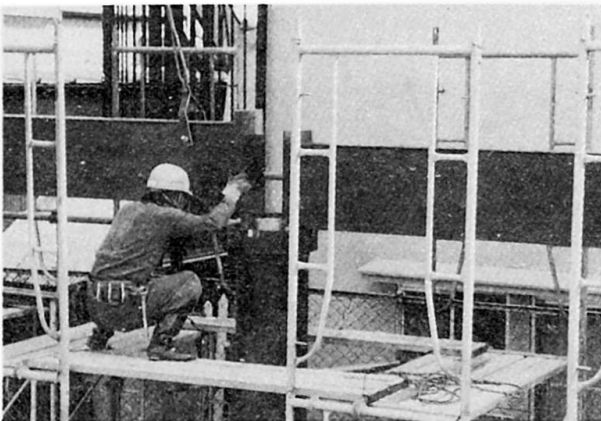

Fig. 5 Beam member

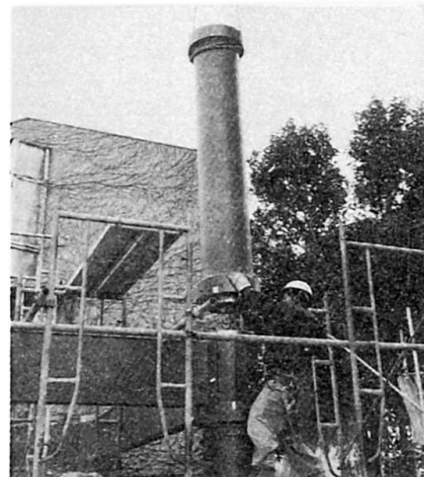

Fig. 6 Column member



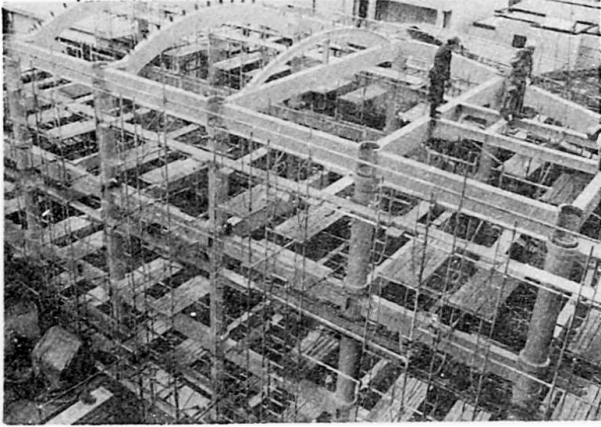

Fig. 7 Whole structure

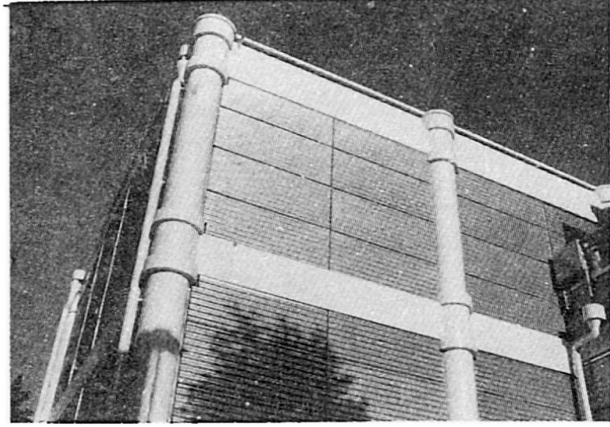

Fig. 8 Completion

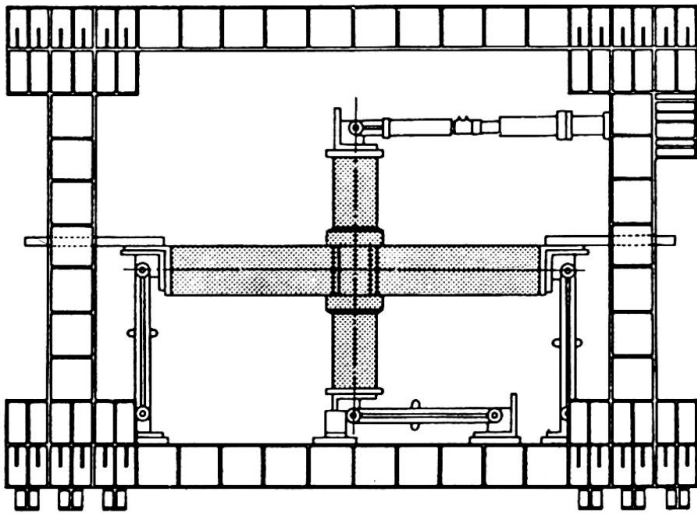

Fig. 9 Testing of column-to-beam joint

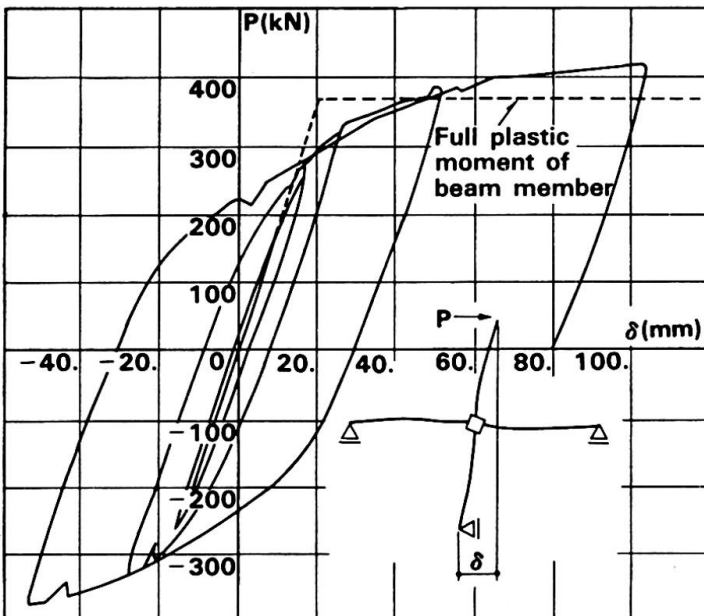

Fig. 10 Relationship of load and deformation

## 6. STRENGTH OF THE JOINT

In order to ascertain the structural strength of the joints of the structure of Fig. 4, an actual-dimension test was conducted on a cross-shaped column-to-beam joint (Fig. 9). During repeated loading at relative story deformation angles equivalent to  $1/50$ , the relationship of load and deformation showed a stable, spindle-shaped hysteresis curve (Fig. 10). The ultimate strength has been ascertained to be in excess of the strength level that corresponds to the entire plastic moment of the beam member. Also, as against the load that corresponds to the design earthquake load, the test piece proved to stay well within the range of elasticity, with deformations of less than  $1/200$  in relative story deformation equivalents. Furthermore, even in the ultimate state, strain in the beam ends and the curved plates was small, and no slipping out of the inserted portion was observed.