

Appendix

Objektyp: **Group**

Zeitschrift: **IABSE congress report = Rapport du congrès AIPC = IVBH
Kongressbericht**

Band (Jahr): **2 (1936)**

PDF erstellt am: **27.09.2024**

Nutzungsbedingungen

Die ETH-Bibliothek ist Anbieterin der digitalisierten Zeitschriften. Sie besitzt keine Urheberrechte an den Inhalten der Zeitschriften. Die Rechte liegen in der Regel bei den Herausgebern.

Die auf der Plattform e-periodica veröffentlichten Dokumente stehen für nicht-kommerzielle Zwecke in Lehre und Forschung sowie für die private Nutzung frei zur Verfügung. Einzelne Dateien oder Ausdrucke aus diesem Angebot können zusammen mit diesen Nutzungsbedingungen und den korrekten Herkunftsbezeichnungen weitergegeben werden.

Das Veröffentlichen von Bildern in Print- und Online-Publikationen ist nur mit vorheriger Genehmigung der Rechteinhaber erlaubt. Die systematische Speicherung von Teilen des elektronischen Angebots auf anderen Servern bedarf ebenfalls des schriftlichen Einverständnisses der Rechteinhaber.

Haftungsausschluss

Alle Angaben erfolgen ohne Gewähr für Vollständigkeit oder Richtigkeit. Es wird keine Haftung übernommen für Schäden durch die Verwendung von Informationen aus diesem Online-Angebot oder durch das Fehlen von Informationen. Dies gilt auch für Inhalte Dritter, die über dieses Angebot zugänglich sind.

Appendix.

Anhang.

Appendice.

Leere Seite
Blank page
Page vide

Yield Limits and Characteristic Deflection Lines.

Ueber Fließgrenzen und Biegekennlinien.

Sur les limites d'écoulement et les diagrammes de flexion.

Dr. Ing. F. Rinagl,

Professor an der Technischen Hochschule Wien.

I. Introduction.

The object of this paper is to throw some light on the fundamental question of the first appearance of yielding in extreme fibres when the distribution of stresses is not uniform, such as in the case of bending, torsion, a perforated or notched member, etc.

Tests carried out by various research workers between 1923 and 1935 (3—14) gave reason for doubting the accuracy of the old yield theories, for substantially higher yield limits were obtained throughout, for unevenly distributed stressing, than tensile tests with the same material had led to expect. We shall assume that the results of these investigations are known. The attempts of the various scientists to clear up the questions involved have not as yet produced any entirely satisfactory solution.

The tests which we shall now proceed to describe, carried out by the author at the Testing House of the Vienna Institute of Technology^{1, 2}, together with the ideas to which they gave rise and the conclusions drawn from them, would seem to bring us a fair step nearer the clarification of the problem.

II. Brief comments on the theoretical impossibility of increasing yield limit to any great extent by preventing deformation.

The height of the yield limit, the diagram of the yield lines and the extent of the yield zone is not, in the case of steel of definite composition, even approximately a fixed value as, for instance, the modulus of elasticity. It is, in fact, dependent on various circumstances. We only have exact knowledge of a few influences, such as the effect of cold working, for which we can make direct forecasts. Other influences, e. g. hot treatment, ageing, etc., can often become so complicated by the process of manufacture, etc., that we must first carry out preliminary tests before we can be sure of obtaining definite values.

Hitherto it has been quite impossible to find any uniform ruling for the appearance of the so-called upper yield limit with decrease in loading. Even when the test material used in the various tensile tests was practically identical as regards its method of manufacture and the utmost care was taken during the tests themselves, the results are always so varied owing to unknown influences that it is

often stated that the upper yield limit is not a property of the material at all, but sets in hap-hazard¹⁶ and suddenly at higher or lower states of stressing, just like retarded boiling when a liquid is heated.⁷

The increase in yield limit discovered by various scientists³⁻¹⁴ for unevenly distributed stresses, has frequently been explained by prevented deformation^{8, 10, 13, 14}. In my opinion the effect of restraint of deformation for unequal stress distribution in perforated or notched bars (set up under certain circumstances even in the elastic range) is but very slight. It is only after the yield limit has been passed that any great coercive stresses can develop which restrain further deformation accordingly. It is not, however, permissible to draw a conclusion relative to initial yield conditions from the plastic state or even from rupture^{18, 19}, for which reason the tensile tests made by *Ludwik* and *Scheu*¹⁷ with the elongation lines of variously notched bars, cannot be cited as a proof of that the yield point has been raised^{32, 33} — a statement which the author does not make. As regards duo-axial stressing conditions there are numerous test results available^{18, 19}. Tests carried out with tri-axial tensile stressing will shortly be completed by the author. In the case of pure bending stressing, however, there exists an absolutely ideal state of uni-axial stressing, and practically speaking deformation restraint due to the state of stressing is theoretically impossible. We shall see in due course that it is only after the yield limit has been passed, in the elastic-plastic state, that the various forms of cross section exert their respective influences.

*Nakanishi*⁷, *Prager*¹⁰, and others assert that yielding only sets in when the bending moment of the entirely plastic state has been attained. In other words, they generalise in an inadmissible manner the phenomenon of abrupt yielding almost to the neutral axis which takes place under bending in steel with high upper yield limit and correspondingly shaped cross sections.

Kuntze's theory¹¹, whereby yielding in the extreme fibres is supposed to set in only when the tensile yield limit has been attained in a certain layer — the so-called centre of resistance — in the interior of the beam, cannot be accepted either. The "centre of resistance" is a purely geometrical allusion and has no physical significance. The approximate coincidence with the results of *Thum's* tests⁸ is only incidental and vanishes as soon as the tests are properly interpreted.

III. The author's tests with large eye bars.

The suspension chains of the new "Reichsbrücke" over the Danube in Vienna^{20, 21} are each composed of 25 elements with 11 or 12 eye bars about 10 m long and back stays, the whole having a weight of about 3500 tons. The eye bars are composed of strips of St 55 plate, 24 mm thick and about 1200 mm wide, with welded-on stiffening plates at the eyes. Tests were made on the Vienna Institute of Technology's 250 ton tensile testing machine with scale pieces 1:3 of the natural size, with the main object of ascertaining the most practical method of connecting the stiffening plates to the central plate. It was owing to the assistance granted by the Austrian Ministry for Trade and Transport, who made it possible to acquire the necessary instruments, that these test pieces could be used for scientific research.

It was decided to take advantage of this rare opportunity of testing such large eye bars, by making exact measurements with a view to producing proof that the frequently maintained theory of the raised yield point was in fact a fallacy.

*Bierett*⁶, too, had declared himself ready to undertake the task of disproving the results of *Eiselin's*⁴ experiments. On the strength of the measurement results obtained, however, he had to confirm them, without being able to give a theoretical explanation for doing so. Contrary to *Bierett's* statements, it was possible, by means of suitable test procedure, to take measurements on both sides of the test piece. Unfortunately, the central plate at the eye was not accessible for measurement, so that there was nevertheless a certain degree of uncertainty as to the distribution of forces acting on the central plate and the two stiffening plates, since the stiffening plates naturally "gave" more owing to rivet deformation.

In consequence of the intricate distribution of forces in eye bars, it was necessary to take successive measurements at many places in at least three directions. There being no room, however, to place tensometers at all these points simultaneously,

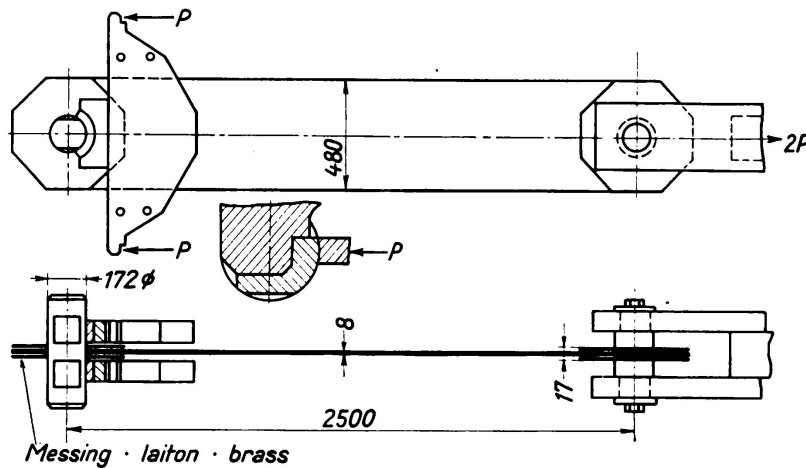

Fig. 1.

the measurements have to be taken one after another and the tensometers transferred a number of times. Small permanent elongations due to increasing load, set up at places where there is no tensometer, might be overlooked during this procedure. For this reason the elongations were measured at important points a comparator microscope, only small measuring lengths being taken on account of the locally varying stressing conditions.

Although permanent deformations were observed at critical places at a much earlier stage than *Bierett* observed them, the apparent raising of the yield limit still amounted to over 100%. Formerly it was always assumed^{22, 23} that at the place where the wall of the hole was subjected to the highest stressing, an equalisation of stresses was set up by yielding at the tensile yield limit. If, however, these plastic elongations are cancelled again by the elastic forces of the eye bar when unloading ensues, then we have no possibility of distinguishing whether the elongation peaks at these places are *real* or only *apparent*.

In order to study these conditions more exactly for a case of clear distribution of stresses, I had a special-shaped bar for bending tests constructed, in which apparently elastic deformations were bound to occur in a particularly perceptible manner. This bar (cf. Fig. 2), whose cross section consisted of a broad rectangle with a light rib placed in the bending plane, was worked up from a round bar of

mild steel, ground and then highly polished so that the yield line patterns could be clearly observed. The loading of the bar was effected with two point loads symmetrical to the centre, and the elongation measurement was taken at the centre part, where the moment remains unchanged. The bar was kept under loading until the elongation measured at the extreme edge of the rib was considerably greater than the elastic elongation at the yield point for the tensile test. In other words, until it was certain that the yield point had been passed in the rib. The

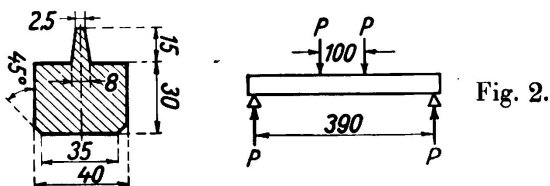

Fig. 2.

bar was now released from load. Owing to the elastic force of the broad rectangular cross section, the deformation of the rib was brought back to such an extent that the tensometer placed at its extreme fibre recorded practically no permanent elongation. From the difference between the permanent elongation resulting from a certain total elongation under bending, and the permanent elongation that would have been set up in a tensile test, it is possible to deduce the remaining stresses (cf. Fig. 3 a b).

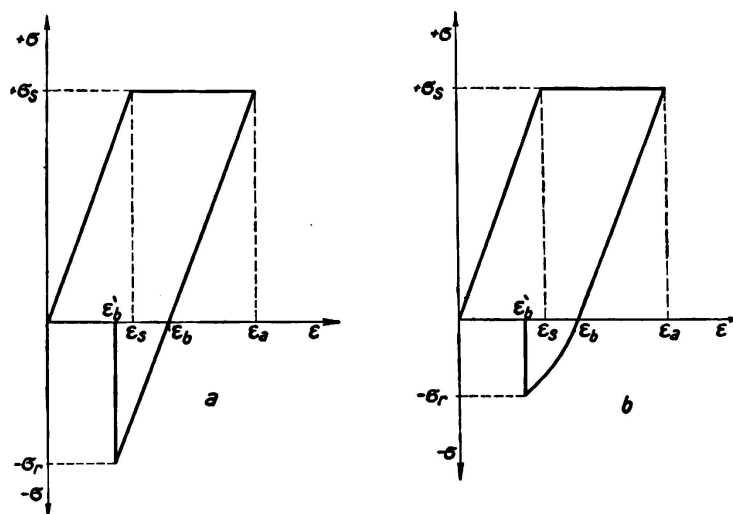

Fig. 3.

With small eye bars specially constructed for elongation measurements it was possible to obtain striking proof that no raising whatever of the yield limit occurs. The elongation and yield of highly stressed fibres takes place just as freely under loading as in the case of what is called the uni-axial state of stressing. Deformation restraint does not occur under loading; on the contrary, a coercive deformation takes place on unloading because the most highly stressed fibres are again forced together so strongly that they almost resume their original length and the theoretical deformations still remaining are so minute that they cannot be measured with any degree of accuracy. When rectangular bars are subjected to pure bending, even in the elastic-plastic state it is possible to deduce the stresses from elongation

or permanent bending measurements. As regards the eye bar, the conditions in the elastic-plastic range are so unclear that no conclusions whatever can be drawn from the customary elongation measurements in three directions. In fact, it cannot even be ascertained whether the yield point has been passed at an individual place or not.

Only drastic action, a radical operation, could be of avail, and this was effected as follows:

The height of the greatest stress peak in the safe elastic range was deduced by exact measurements on an eye bar specially constructed for elongation measurements. Then the loading was increased until it was certain that the yield limit had been passed at the most highly stressed place. After unloading the measurement marks previously notched at this place revealed no displacement with regard to each other. The eye bar was now sawn through the crown and cheek sections until the wall of the hole is almost reached, so that back-spring action was eliminated. The place remaining under compressive stress after unloading could now expand freely, a fact that could be definitely ascertained by the elongation of the distance between the notches. It is thus indisputably proved that plastic deformations have really taken place at the base of the notch.

Simple bars of various cross sections were also submitted to bending tests at the same time as the eye bar. These we shall deal with later on. First of all, however, let us again devote our attention to clarifying the theoretical relations in the elastic-plastic range.

IV. Nomenclature.

For the deductions about to be made in the next section, we shall adopt the following designations:

M	variable bending moment	
M_s	bending moment for lower yield point ($M_s = \sigma_s \cdot W$) [cmkg]	
M/M_s	values of deflection curves	(1)
$H_{0.2} M_{0.03}$	etc. 0.2 % of bending moment limit, etc.	
M_{s_0}	bending moment for upper yield point [cmkg]	
M_T	ultimate carrying capacity bending moment (moment of deformation by bending)	
M_n	bending moment for exhausted yield	
ϵ	elongation (upsetting)	
ϵ_a	deformation of extreme fibres	
ϵ_b	permanent deformation of extreme fibres	
ϵ_s	deformation of extreme fibres at lower yield limit, under bending, tension or compression	(1)
ϵ_n	deformation at end of yield range	
$n \epsilon_s$	yield range	
σ_s	lower yield limit for bending, tension or compression (kg/cm^2)	
σ_{s_0}	upper yield limit for bending, tension or compression	
$\sigma_{0.2}$	etc. 0.2 % of elongation limit	

e	ratio value	$e = \varepsilon_s / \varepsilon_a$
k	ratio value	$k = \sigma_{s0} / \sigma_s$
S	static moment of half cross section in respect to neutral axis (cm^3)	
W	modulus of section	

For an elucidation of the designations applied compare the lines representing elongations under tension (stress-strain diagram) in Fig. 4 a b and the lines representing moment-extreme fibre elongation in Fig. 5. For a purely elastic state of stressing the bending moment M increases in the form of a straight line with the extreme fibre elongation ε_a , until at the bending moment for lower yield point M_s , the first yield occurs in the extreme fibres at an extreme fibre elongation of ε_s , if the material only possesses a lower yield limit σ_s (cf. Fig. 2a). In the range of elastic-plastic

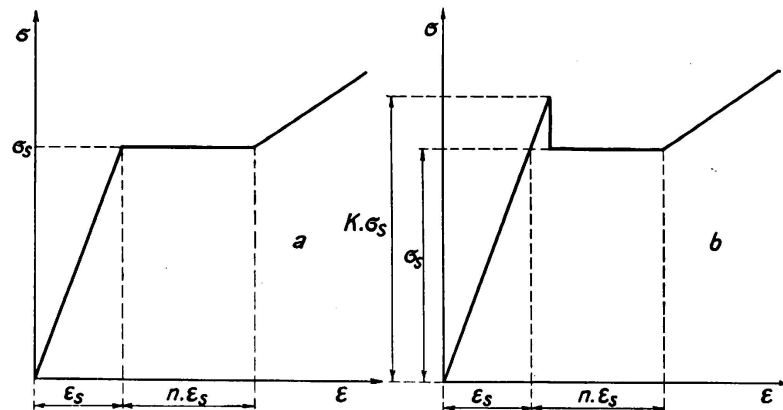

Fig. 4.

deformations the bending moment increases as shown in the equations to be appended, when the yield stress σ_s remains constant throughout the yield range $n\varepsilon_s$ (Fig. 4a). The calculated moment-extreme fibre elongation line tend asymptotically to approach a limit value M_t , whose magnitude is dependent on the shape of cross section. In reality it only remains valid until the moment M_n is reached, when hardening occurs and the moment increases more rapidly. Respectively with the magnitude of the admissible permanent deformations $\varepsilon_b = 0.2, 0.03$ and 0.01% , various bending moment limits $M_{0.2}, M_{0.03}$ and $M_{0.01}$ are obtained.

If the material possesses a pronounced upper yield limit (cf. Fig. 4b), the first permanent deformation will only appear at the bending moment M_{s0} for upper yield point. The bending moment for lower yield point, M_s , calculated from the lower yield point on the equation $M_s = \sigma_s W$, is in this case only of theoretical significance. The path of the moment-extreme fibre elongation line is shown in dashes and can be calculated for varying $k = \sigma_{s0} / \sigma_s$ under certain circumstances. The upper yield point, however, has no influence on the magnitude of M_t , the ultimate carrying capacity moment, as will be seen in due course. Figs. 7 and 8 are drawn without reference to the lower yield point σ_s , the ratios M/M_s and $\varepsilon_a/\varepsilon_s$ being put in upwards and to the right respectively. The lines thus obtained are briefly called "values of deflection curves" of the respective cross sections; for example, we say "the deflection curve for $K = 1.3$ " when an upper yield point $\sigma_{s0} = 1.3\sigma_s$ has been considered.

V. Derivation of ideal deformation lines for pure bending (characteristic deflection lines).

For a material whose deformation line is identical for tensile and compressive stressing, viz. purely elastic up to the yield point and purely plastic inside the range of yield (cf. Fig. 7a), the deformation line under simple bending can be determined with relative ease for some shapes of cross section when it is assumed that for plastic deformation, too, the cross sections remain plane and at right angles to the axis of the bar. For a beam of rectangular section, with a height h and a breadth b , the plastic deformation under bending, for a yield limit σ_s , would be propagated from the exterior to within a distance z of the neutral axis (cf.

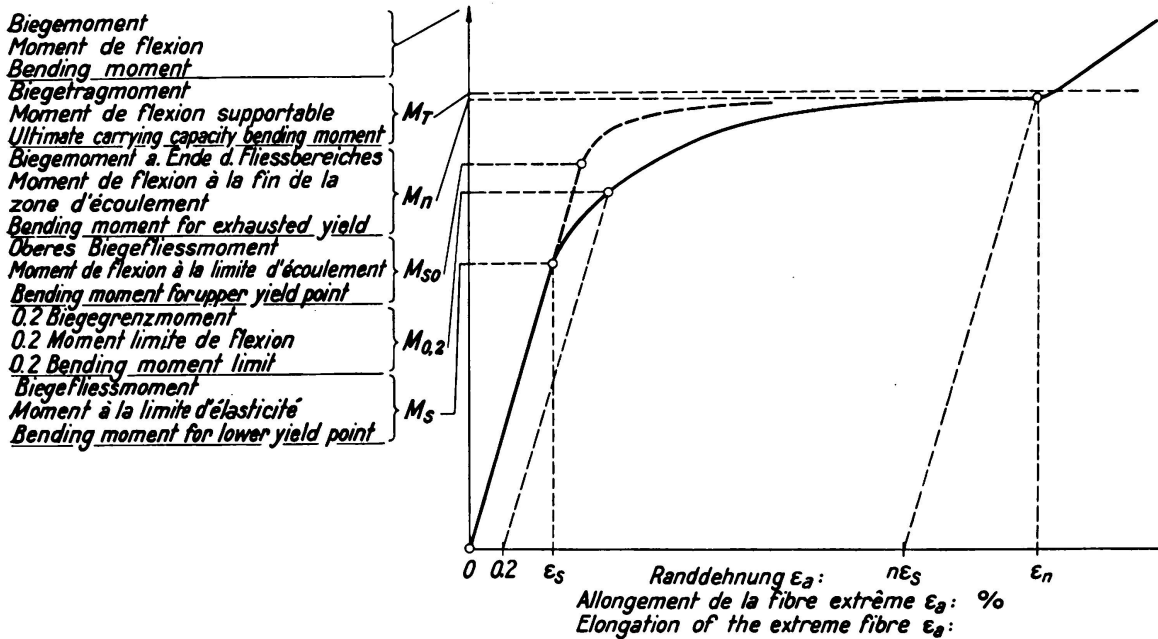

Fig. 5.

Fig. 6), while the interior, with a height of $2z$ is still in a purely elastic state. If ϵ_a denotes the respective specific elongation of the extreme fibres and ϵ_s the specific elongation when the yield limit σ_s is reached, the following relation becomes valid for the variable bending moment M :

$$M = b \cdot \left(\frac{h}{2} - z\right) \cdot \left(z + \frac{h}{2}\right) \sigma_s + \frac{b \cdot 4z^2}{6} \sigma_s = b \cdot \sigma_s \left(\frac{h^2}{4} - \frac{z^2}{3}\right)$$

and on introducing $z = \frac{\epsilon_s}{\epsilon_a} \cdot \frac{h}{2}$ we obtain

$$M = \frac{bh^2}{12} \sigma_s (3 - \epsilon_s^2/\epsilon_a^2). \text{ Compare Fritsche 20).}$$

To obtain the same comparison curves for materials of the same cross section but with different yield limits, the ratio M/M_s in Figs. 7, 8 was drawn upwards and the ratio ϵ_a/ϵ_s to the right, M denoting the variable moment of bending and M_s the moment during transition from the purely elastic to the elastic-plastic state. The following relation is then obtained for the rectangular bar, whether it is laid flat or on edge:

$$\frac{M}{M_s} = \frac{1}{2} \cdot \left[3 - \left(\frac{\epsilon_s}{\epsilon_a} \right)^2 \right]$$

representing a curve of the third order of the form $y = a - \frac{b}{x^2}$ with an asymptote at a distance of $y = 1.5$ and a tangent at origin following *Hooke's* straight line law.

For a yield zone of $\epsilon_s = 5 \epsilon_3$ ($\sim 1\%$ in mild steel), the ratio M/M_s already approaches the limit 1.5 (cf. Fig. 8) to a sufficient degree of approximation. The equation of the curve now established remains valid as long as the extreme fibre elongation ϵ_a does not go beyond the actual yield zone, which for steel can amount to 1.5–2% and more.

In the same manner we obtain for a number of simple cross sections the equations of the deformation curves, which of course are only valid as long as no hardening takes place. Applying the simplified term $\epsilon_s/\epsilon_a = e$, the following relations are valid for the characteristic deflection curves (cf. Fig. 7):

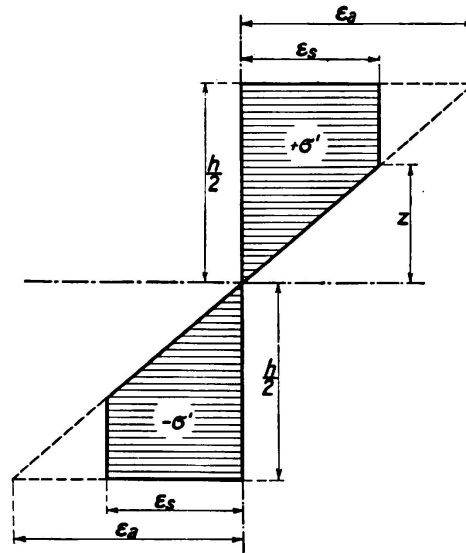

Fig. 6.

Rectangular bar, whether laid flat or on edge.

$$\frac{M}{M_s} = \frac{1}{2} (3 - e^2)$$

$$\text{Limit } \frac{M}{M_s} = 1.5.$$

Square bar, bent cornerwise.

$$\frac{M}{M_s} = 2 \left(1 - e^2 + \frac{1}{2} e^3 \right)$$

$$\text{Limit } \frac{M}{M_s} = 2.0.$$

VI. The limiting case of purely plastic bending.

The limiting values $\frac{M_f}{M_s}$ for the purely plastic state of stressing at which the yield stress σ_s is attained throughout the cross section, can be determined directly in a known manner. For reasons of equilibrium the neutral axis and the line bisecting

the area coincide. In general (cf. Fig. 13), the following holds good for the moment M of the internal forces:

$$M_T = \int_0^{h_1} \sigma_s \cdot b_1 \cdot z_1 \cdot dz_1 + \int_0^{h_2} \sigma_s \cdot b_2 \cdot z_2 \cdot dz_2 = \sigma_s (S_1 + S_2)$$

S_1 and S_2 denoting the static moments of the halves of the cross sectional area above and below the neutral axis. The following simple moment relations are now obtainable for bars under bending with rectangular, square, circular and triangular cross sections:

Breadth b , height h .

$$M_T = \frac{bh^2}{4} \sigma_s \text{ for purely plastic state,}$$

$$M_s = \frac{bh^2}{6} \sigma_s \text{ for purely elastic state,}$$

$$\text{hence } \frac{M_T}{M_s} = 1,5.$$

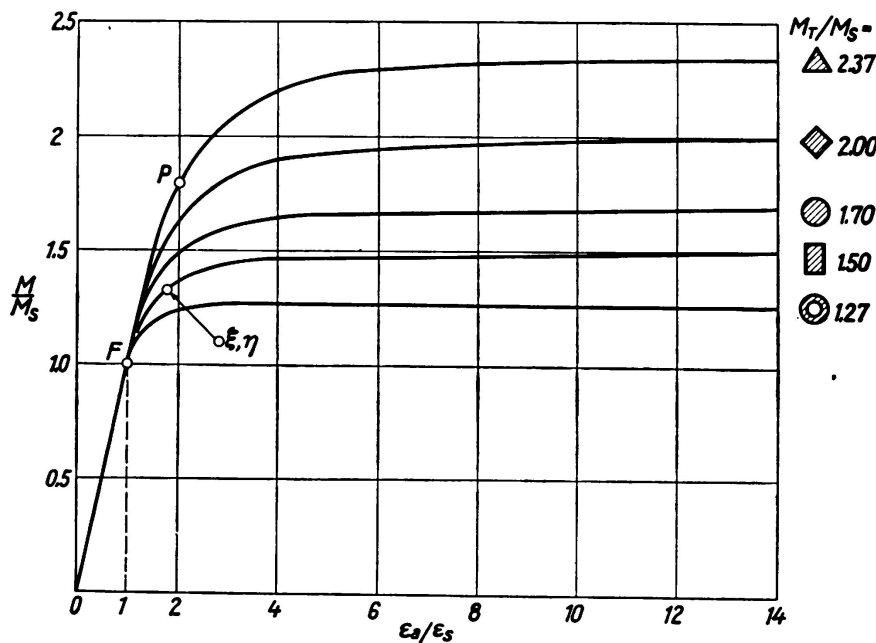

Fig. 7.

Square bar, bent cornerwise. Diagonal d .

$$M_T = \frac{d^3}{12} \sigma_s \quad M_s = \frac{d^3}{24} \sigma_s \quad \frac{M_T}{M_s} = 2,0,$$

VII. Bending yield limit.

From the characteristic deflection lines established (Fig. 7) it is clear that it is not possible to arrive by bending tests at an exact determination of the bending yield limit, since for various forms of cross section the transition from the purely elastic to the elastic-plastic state at the point F only takes place gradually. This also applies for materials with a pronounced yield limit under tensile or compressive

stressing as in Fig. 4a; it is on this limiting case that the calculated deflection lines are constructed. In tensile tests giving an indistinct yield limit, without a pronounced kink in the stress-strain line but instead a gradual transition, an elongation limit of 0.2% was agreed upon as a substitute for the yield limit, thus making it possible to adopt a uniform testing procedure and eliminating arbitrary measures. This expedient, however, fails in the case of a bending test, as the following consideration shows:

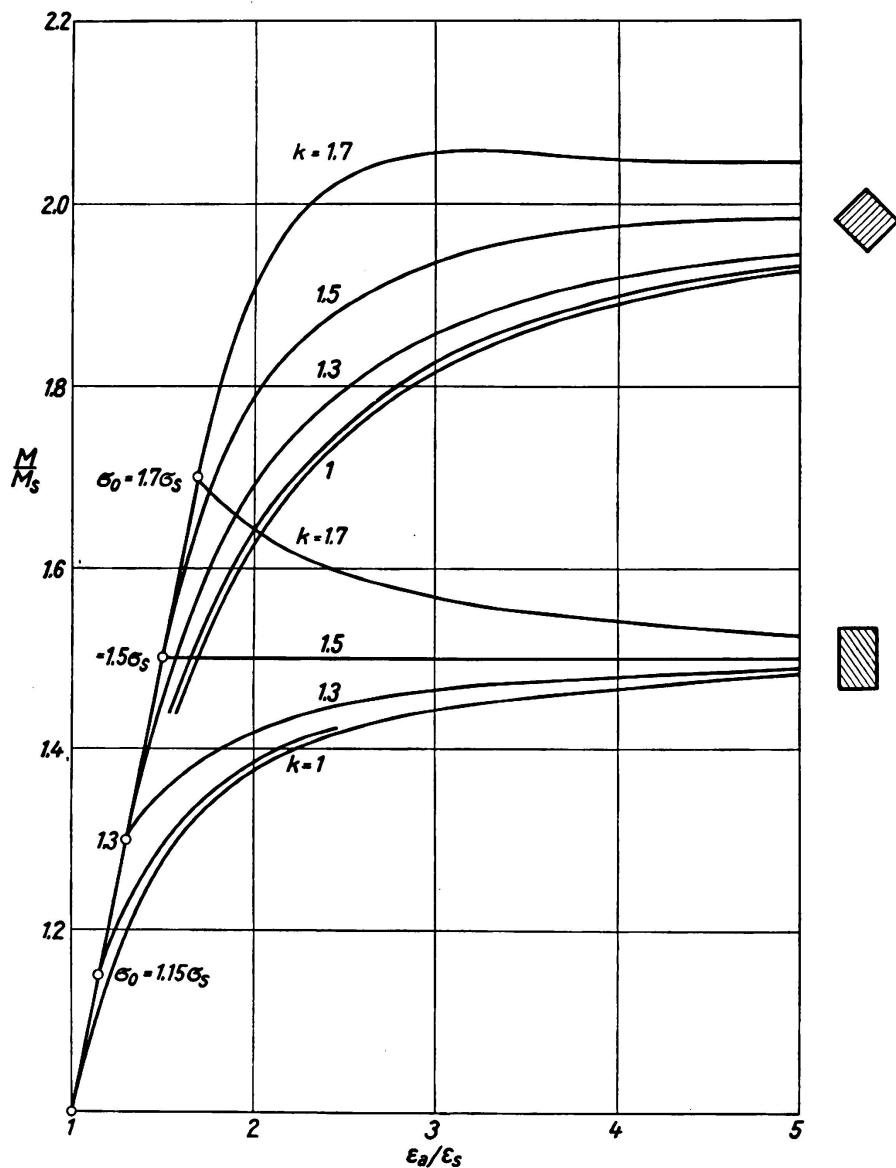

Fig. 8.

Since steels possess an approximately equal modulus of elasticity E , the elongation ϵ_s at the extreme fibres depends in linear relation on the height of the yield limit σ_s when the yield-point bending moment M_s is reached. Choosing a definite bending moment limit (e. g. $M_{0.2}$) corresponding to a permissible permanent bending deformation (e. g. $\epsilon_b = 0.2\%$), as well as the specific elongation corresponding to a definite tension-compression yield limit σ_s , the elongation ratio ϵ_b/ϵ_s , valid

for these assumptions, can be used to obtain the unloading straight line according to *Hooke's* law, as shown in Fig. 10. For the shape of cross section under consideration there results at the intersection, with its characteristic lines of deflection, the moment ratio (e. g. $M_{0.2}:M_s$), and thus also the apparent increase of the bending yield limit. The values would be somewhat higher if, for the unloading the *Bauschinger* effect (Fig. 3b) had been taken into consideration. For the sake of simplicity, however, this factor was neglected and the apparent rise of the yield limit determined for various σ_s and ε_b and listed in Table 1. In doing so it was assumed that the tension-compression yield limit could be exactly determined. If the 0.2% elongation limit has to be used instead of it, further factors of uncertainty are introduced.

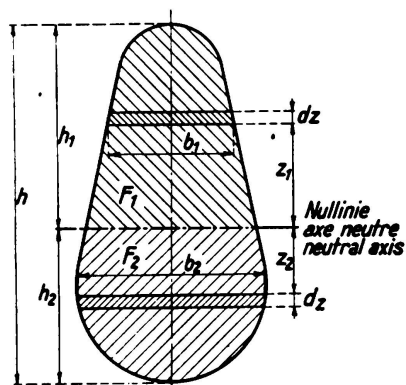

Fig. 9.

Table 1.

Rectangular section $\varepsilon_b = 0.002$, $E = 2.10 \cdot 10^6 \text{ kg/cm}^2$

Pronounced tension yield limit $\sigma_s \text{ kg/mm}^2$	Elongation at yield limit ε_s	Ratio:		Moment ratio $M_{0.2} : M_s$	apparent rise of bending yield limit %
		Permanent elongation to at yield limit $\varepsilon_b/\varepsilon_s$			
20	0.001	2		1.47	47
40	0.002	1		1.42	42
60	0.003	0.66		1.37	37
80	0.004	0.5		1.35	35
$\varepsilon_b = 0.0003$, $E = 2.10^6 \text{ kg/cm}^2$					
20	0.001	0.3		1.30	30
40	0.002	0.15		1.24	24
60	0.003	0.1		1.20	20
80	0.004	0.075		1.18	18
$\varepsilon_b = 0.0001$, $E = 2.10^6 \text{ kg/cm}^2$					
20	0.001	0.1		1.20	20
40	0.002	0.05		1.16	16
60	0.003	0.033		1.13	13
80	0.004	0.025		1.11	11

VIII. The upper yield limit in tension and bending tests. Consequences of slight eccentricity.

*Ludwik*²⁵ has devoted careful study to the various influences acting on the height of the yield limit in tensile tests and on the type of yield pattern obtained, and

was the first to explain the kink and drop occurring at the yield limit as being due to processes of separation. There was, however, no means of finding a law for determining the height of the upper yield limit, for tensile tests with test bars that had been taken in direct succession from a carefully annealed steel rod gave a succession of varied and irregular upper yield limits or no load drop at all. These unpublished tests were carried out with the same testing machine, the same shape of test piece and in as similar a manner as possible, and as carefully as possible. Some unknown and indeterminate influence caused these contradictory results, so that no law could be found. Moser¹⁶ also reports on similar phenomena and declares that steels can actually have "moods" when it is a question of determining the upper yield limit. Körber and Pomp²⁶ investigated the influence of the shape of the test bar, the manner of restraining same, the speed at which the test was carried out and the type of testing machine used, on the position of the upper and the lower yield limit of steel in tensile tests. For this purpose carefully chosen steel specimens were tested in four different laboratories in Germany and the results compared. Though the lower yield limit was found to be the same — the differences were slight — in all four institutes, the results obtained for the upper yield limit varied excessively. The individual influences at work could not be classified without inviting contradiction, so that the author rightly came to the conclusion that acceptance tests offer no suitable means of determining the upper yield limit.

In our bending tests the upper yield limit was reached with great regularity at the same height and in nearly every case was more than 20% higher than in the tensile test, so that the cause was obviously to be sought in the nature of the tensile test or in some deficiency pertaining to it. When making tensile tests it is our endeavour to attain as equal a distribution of stresses as possible over the whole cross section; we are aware, however, that this ideal is hardly ever entirely achieved. When determining the coefficient of elongation exact measurements of the minute elongations must always be taken on two opposite sides of the test bar, since these elongations are by no means identical on both sides. It is only by taking the mean of the two that we obtain the mean elongation corresponding to the calculated stressing at the centre of gravity and thus the coefficient of elongation. The unequal elongations are caused by additional bending stressing originating in slight eccentricities, the cause for which is to be found partly in the fixing of the test bars, partly in the material itself.

Let us now consider the transition from elastic to plastic state. If there is no eccentricity or irregularity whatever present, the upper yield limit will also be correctly indicated in the tensile test. However, the slight eccentricity which generally does exist can have the effect of increasing the stresses on the one side of the bar by 10—30% over those on the other side. Thus when medium stress is applied — corresponding to the lower yield limit — the upper yield limit may already have been reached on the one side and the whole yielding process prematurely commenced. The degree of eccentricity (e) now becomes of interest, and it can easily be calculated. If the test bar has a circular cross section with a diameter (d), or rectangular with a breadth (b) and a thickness (h), and if it were so stressed by the tensile force P that on one side of the test bar the upper yield limit σ_0 is just reached and lies 20% higher than the lower yield limit of the material as such, while the stressing at the centre of gravity would only just reach the lower yield

limit, then for eccentric tensile stressing in a bar of rectangular cross section we have

$$\sigma_{so} = 1.20 \sigma_s = \frac{P}{b \cdot h} + \frac{P \cdot e}{\frac{b h^2}{6}} = \frac{P}{b h} \cdot \left(1 + \frac{6e}{h}\right)$$

from which results

$$\frac{6e}{h} = 0.2 \text{ or } e = \frac{h}{30}$$

and for a circular cross section

$$\sigma_o = 1.20 \sigma_s = \frac{P}{\frac{\pi d^2}{4}} + \frac{P \cdot e}{\frac{\pi d^3}{32}} = \frac{P}{\frac{\pi d^2}{4}} \left(1 + \frac{8e}{d}\right) \text{ and } e = \frac{d}{40}$$

In the ordinary tensile test, then, there is no longer an upper yield limit of 20% to be recognised when there is eccentricity of $\frac{1}{4}$ – $\frac{1}{3}$ mm in a test bar of a thickness d — or h — of 10 mm. Eccentricity of this kind is inevitable when the bar is restrained with the wedge clamps so frequently used for the purpose. For tensile tests to determine the upper yield limit, round bars with an easily adjustable spherical movement are to be recommended, as I have already suggested.²⁷ The test is most likely to be successful if carried out with specimen bars having long, conical transition and only short middle portions.

Till now nobody has thought of the consequences of slight eccentricity since, as already mentioned, when taking exact measurements in the elastic range only the mean elongation was taken, the extreme fibre stresses were disregarded, and when the yield limit had been exceeded the initial eccentricity was considered to be of no importance.

In bending tests, according to experience hitherto made, the upper yield limit seems to penetrate practically to its full extent into the depth of the bar and the lower yield limit to follow it. In some tests, however, disturbances occurred, the origin of which is still being investigated.

As in Section X, we can calculate the theoretical path of the characteristic deflection curve for an ideal material, using $\sigma_{so} = k\sigma_s$ as a basis. Now the following relations apply:

Rectangular bar:

$$\frac{M}{M_s} = \frac{1}{2} \left[3 - e^2 k^2 (3 - 2k) \right]$$

Square bar, bent cornerwise:

$$\frac{M}{M_s} = 2 \left[1 - e^2 k^2 (3 - 2k) + e^3 k^3 (4 - 3k) \right]$$

On these equations we have deduced (Fig. 8) the characteristic lines for $k = 1.15, 1.3, 1.5, 1.7$ for a square lying flat and one cornerwise respectively.

As was to be expected, the upper yield limit σ_{so} exerted *no* determinable influence on the ultimate carrying capacity bending moment in a purely plastic state. Its *influence*, as may easily be realised, is *vastly different* for various shapes of cross section.

IX. Possibility of an unstable bending process.

In steel *without* an upper yield limit the characteristic deflection curve rises constantly for all shapes of cross section. A definite bending moment always corresponds to a definitely determined extreme fibre elongation or deflection respectively. On increasing the bending moment by increasing the load the plastic zone extends further towards the neutral axis until the new distribution of stresses causes a new state of equilibrium and deflection gradually ceases.

Steel *with* an upper yield limit, however, is another matter. If this yield limit is sufficiently high, the bending moment may become as great as or greater than the ultimate carrying capacity bending moment in the entirely plastic range, when yielding of the extreme fibres first sets in (bending moment for upper yield point). Compare Fig. 8, which illustrates the characteristic deflection lines for a square bar lying flat and one cornerwise, at upper yield limits situated 15, 30, 50 and 70% above the lower yield limit ($k = 1.15, 1.30, 1.50, 1.70$). When the square section lies diagonally, all the lines drawn rise steadily, while when it lies flat, only those for which the upper yield limits are lower than 50% do so. Where the upper yield limit lies above this figure, the characteristic deflection line, in the elastic-plastic range drops more or less rapidly to the value of the entirely plastic state. In this case, as soon as the upper yield limit has been exceeded at one point of the test bar, the whole section, from the extreme fibre almost to the neutral axis, will commence to yield, provided the testing apparatus is so constructed that automatic unloading is impossible. The simplest means of avoiding the latter is by applying direct weight loading. Equilibrium is only regained when the whole range of yield has been traversed and hardening begins at the extreme fibres. Loading tests which have been carried out confirm these observations in a very convincing manner. For purely bending stressing the elastic line forms an arc until the bending moment for yield point is attained. If, however, the upper yield limit is exceeded at any point, the bar is only deformed the more at this point, forming a more or less abrupt bend, whereas at the other parts of the bar the curvature assumed when the bending moment for yield point was reached does not change. When the deformed portion has hardened, another part begins to yield, and here again an abrupt, rounded bend is formed. This process may be repeated at various places. Fig. 10 shows two bars after unloading in a bending test. The small plastically deformed zones at the rounded corners are clearly visible owing to the peeled-off rolling skin. The yield point was not exceeded at any other part of the bar; these other portions became straight again after unloading.

Thus we have also a clear and evident explanation for the fact that after an apparent retardation the yield lines suddenly set in and penetrate the whole cross section, almost till the neutral axis is reached, in a series of jerks. The observation made by several scientists was therefore quite correct; only *Pragers'*¹⁰ explanation was not credible and was without foundation.

In the case of I-sections the ultimate carrying capacity bending moment is only about 18% greater than the moment for yield point (compare *Fritsche's* calculations²⁴). As an upper yield limit of up to 20% above the lower is almost the general rule in mild steel, and steel entirely without an upper yield point is a rare exception, we must always reckon when dealing with I-sections that when the yield limit has been exceeded the plastic state penetrates to a considerable depth (cf. also *Kollbrunner's* tests²⁸).

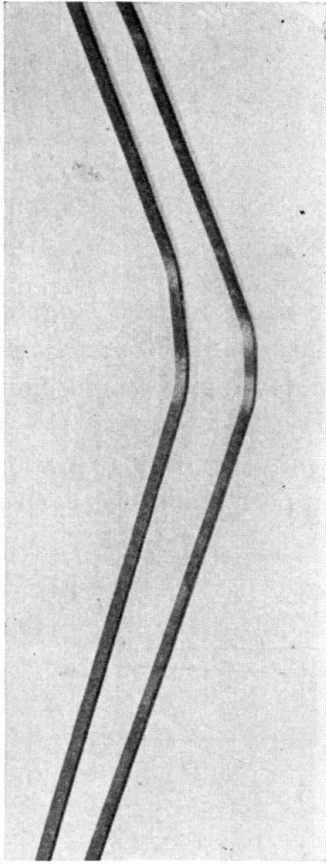

Fig. 10.

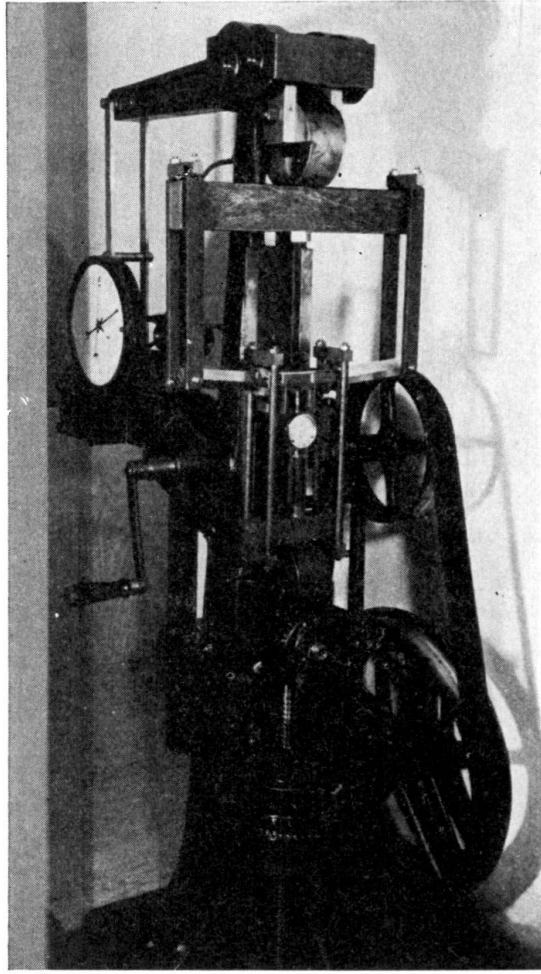

Fig. 11.

The labile processes set up under certain circumstances in consequence of the upper yield limit, and the local limitation of deformation, can also prove to be of great importance in other forms of tests. The cause of the extremely slight resistance to notching action of steel of high upper yield limit is also to be traced back to this as well as other factors. It is worthy of note that the fatigue bending strength of steel of high upper yield limit, in the form of both polished and notched bars, is considerably greater than was to be expected from the lower yield limit results calculated after tensile tests. Rectangular bars of steel without an upper yield limit revealed, when subjected to bending tests under weight loading, unaltered curvature and no unstable conditions whatever over the whole equally stressed length of the bar, even when the yield limit had been exceeded and right up to the entirely plastic state.

X. Bending tests with deflection and elongation measurements, carried out by the author.

For the tests in question steels with various characteristic properties were employed (cf. Table 2), and wherever possible all the bars for tension, compression and bending tests were taken from the same steel rod which had been previously tested by a ball thrust machine (Brinell) for equal hardness along the whole of its length. The ball thrust tests were made on four sides of the bar at intervals of 20 cm.

Table 2.

Type of steel		Lower yield limit kg/mm ²	Lower up- setting limit kg/mm ²	Yield range %	Upsetting range %	Tensile strength kg/mm ²
Carbon	A	22.0	22.0	15	10	37.4
"	B	21.7	22.0	15	9	37.5
"	R	20.3	21.7	10	10	40.6
"	S	36.0	36.7	8	6	74.6
3% Nickel	M	50.5	51.2	10	10	69.2
VCN 35	C	94.0	94.0	5	5	104.5

For the tensile tests round bars with shoulders were used, for the compression tests cylinders $h = 3d$, and for the bending tests prismatic bars 470 mm in length. The bending tests were carried out by a *Amsler* 2-ton tearing machine equipped with inclination balance that *Ludwik* liked to use. For this purpose the knife-edge suspension shown in Fig. 11 was made, enabling pure bending to be applied to the middle portion of the bar without disturbing support reactions, even when

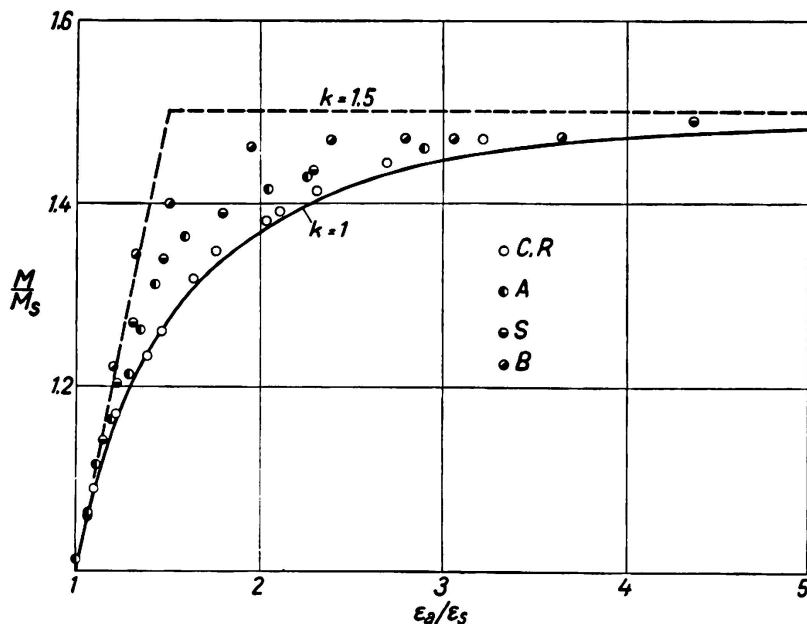

Fig. 12.

the deflections produced were very great. The deflection was measured on two points of the neutral axis by means of a Zeiss deflection gauge, and the elongation, i. e. the upsetting, at the extreme fibres of the bar with the aid of from two to four

Huggenberger tensometers. The loading was applied in successive stages, unloading taking place only in very few instances. Frequently, when the yield range was reached, the bars had to be allowed to remain a considerable time under the same load before the indicators came to rest. When subsequent, secondary yielding was prolonged, however, it was not possible to wait so long owing to the danger

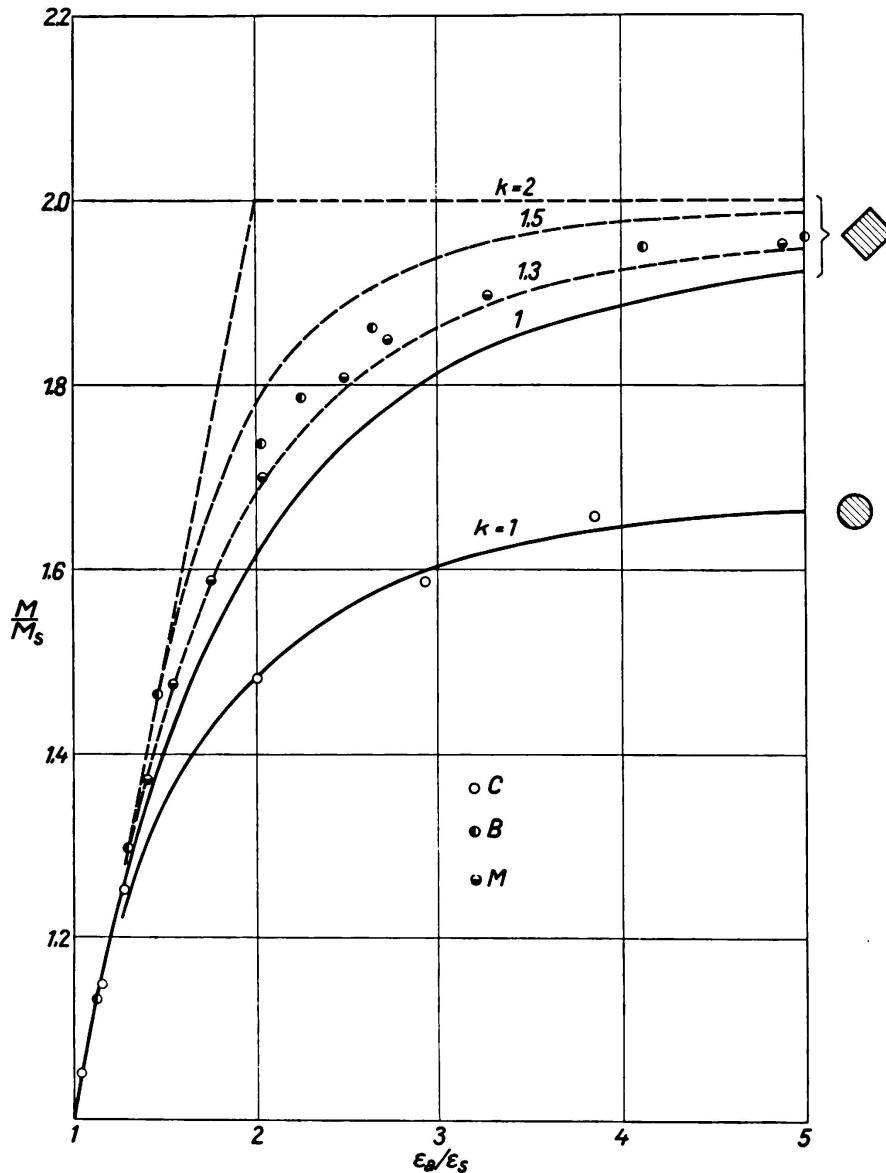

Fig. 13.

of other ageing phenomena appearing, for which reason further loading was proceeded with throughout if the deflection increased less than 0.01 mm in ten minutes. Fig. 12 shows the results of bending tests on rectangular and square bars lying flat, Fig. 13 those for square bars bent diagonally and round bars. It will be noted that, to save space, only the elasticplastic range, proceeding from $M/M_s = 1$ and $\epsilon_a/\epsilon_s = 1$, are given, as for instance in Fig. 8. For the sake of clarity, in most cases only those test results were marked with a ring which deviated from the theoretical curves by more than 1%.

It was a fortunate coincidence that two of the materials used proved to have no upper yield limit even under bending and therefore displayed perfect coincidence with the characteristic bending curves for $k = 1$. The remaining materials, whose upper yield limit could not be determined by the tensile tests either, nevertheless

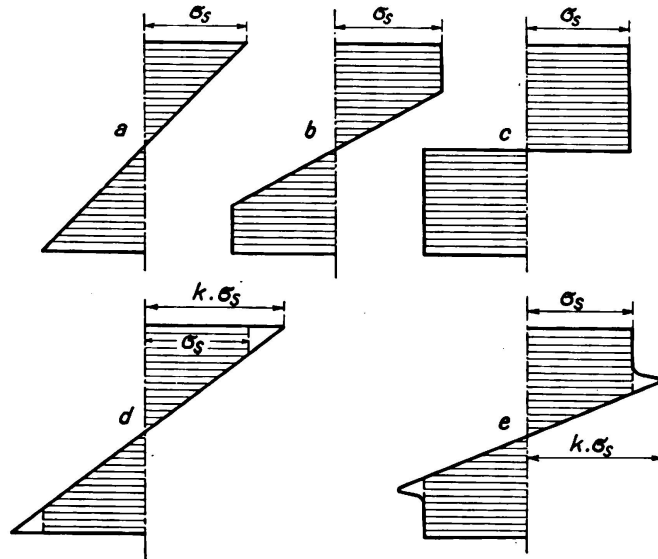

Fig. 14.

displayed ruled deviations under bending; these were recognised as being effects of the upper yield limit of the materials concerned. In mild carbon steel an upper yield limit would seem to exist as a rule, while steel entirely *without* an upper yield limit appears to be an exception. The mild carbon steel R and the annealed chromium

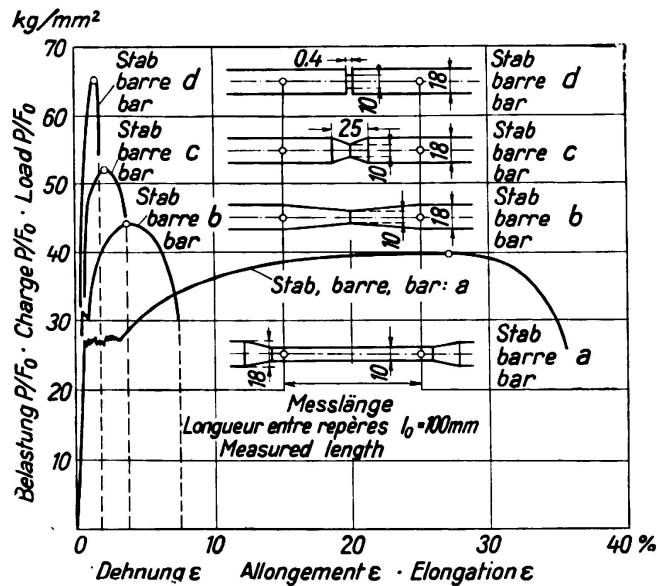

Fig. 15.

nickel steel C gave test results (both for rectangular and square section lying flat — Fig. 13 — and for square bars bent cornerwise) that coincided almost exactly with the characteristic bending curve $k = 1$. This was also the case for the round bar of C steel. These two types of steel thus had no upper yield limit. By appropriate treatment in an annealing oven it was easy to obtain cementite separation of grain

size limits and to impart a high ($k = 1.5$) upper yield limit to steel R. The upper yield limit thereby rose to 23.9 kg/mm², while the lower dropped to 16.0 kg/mm². It was not, however, possible completely to re-create the original condition. These tests are still proceeding.

Steels A, B, M and S, which under tension proved to have only a very indistinct upper yield limit, or none, whatever, all revealed upper yield limits of the same height when subjected to flat and cornerwise bending in square section. Steels A and S gave perfect coincidence with the characteristic bending line for $k = 1.3$, both in Fig. 12 and also in Fig. 13. Steel M corresponds in Fig. 12 to the characteristic curve $k = 1.3$, while in Fig. 13 the values are all somewhat higher. Steel B reveals for both shapes of cross section a 40% upper yield limit ($k = 1.4$), with but slight deviations.

Steel bars with self-stresses caused by annealing, straightening, etc., also gave great deviations under bending, as was to be expected. A detailed report of the tests will be issued in the form of a Publication of the Technical Testing Institute (Mitteilung der Technischen Versuchsanstalt).

I should like to take this opportunity of thanking my collaborators, and particularly Ing. Dr. *Wilhelm Blauhut*, Ing. Dr. *Josef Stich* and Ing. Dr. *Stefan Sztatecsny*, for their assistance and for the exact manner in which they carried out the tests.

XI. Views on earlier tests.

*Eugen Meyer*¹⁵ found the yield point for bending to be 44% higher than the tensile yield limit, though he was aware that the bending stress calculated on the equation $\sigma = M/W$, which is only valid in the purely elastic range, can only be a theoretical or apparent stress. *Preuss*²⁹, too, in his tensile tests on notched and perforated bars, expressed the high elongation peaks in terms of stresses for the sake of better comparison, at the same time, however, he bracketed the values so obtained and emphasised the fact that they did not represent real stresses greater than the yield limit. *Lasche*³⁰, on the other hand, recorded stresses greater than the yield limit when making tests on discs.

Thum and *Wunderlich*⁸ calculated the yield limit for bending from the bending moment at which greater deflections were set up, basing his calculation on $\sigma = M/W$; he found it to be higher than the tensile yield limit, since very considerable plastic deformations had already occurred. *Prager's*¹⁰ calculations, already mentioned, showed that in I-sections the entirely plastic state had already been reached before yielding occurred. This state was also nearly attained in square bars lying flat and in round bars, while the tests were abandoned at an earlier stage in the case of the diagonally bent square bars and some of the rectangular ones. The shape of the beam, as recent experience has shown, exerts no influence, at least where static bending tests are concerned, though it certainly affects the further flow of yielding.

*Chwalla*¹² determines the real extreme fibre stresses set up from the extreme fibre elongations, using equalisation lines for the purpose.

A specific extreme fibre elongation of over 1% having been measured in Test 2 for the greatest bending moment (compare Fig. 3 of the treatise), our Fig. 7 may lead us to expect that the ultimate carrying capacity bending moment M_T , corresponding to the purely plastic state, was almost attained. Thus we can also calculate

the stress on the equation $\sigma = \frac{M}{2S} = \frac{140250 \text{ kg/cm}}{43.6 \text{ cm}^3} = 32.2 \text{ kg/mm}^2$, which coincides quite well with the lower yield limit value of 32.4 kg/mm^2 for bending tension and bending compression, as determined by *Chwalla*. According to our deduction and tests, this value must also be the lower tensile yield limit which, however, proved to be only 24.7 kg/mm^2 for normal bars in tension under the same load. This disagreement with the results of the tensile tests has meanwhile been explained by *Chwalla* as being due to lack of uniformity of material in bars used for tensile and bending tests.³¹ The bars for tensile tests subsequently taken from the rods subjected to bending gave a lower yield limit of 29.6 kg/mm^2 . This result, therefore, now deviates by no more than 10% and no longer justifies the conclusion that this stress has been markedly increased.

Siebel and *Vieregge*¹³ measured the deflection of various materials in their bending tests and determined the yield limit from the sudden change of direction of the deflection lines; this they then called the "upper yield limit for bending". The "lower yield limit for bending" was obtained from the moment for which the purely plastic state was reached and was found to be practically the same as the lower yield limit for tension, so that there is quite good coincidence with the results of our tests. The "lower yield limit" calculated from the results of torsion tests lies between the known values 0.50 and 0.57 of the tensile yield limit. The varying increase in the height of the upper yield limit, however, as obtained for steels with different yield limits, is likely to be only apparent (compare our explanations in VII. Bending yield limit, Table 1.

Reference Works.

¹ *F. Rinagl*: Keine Erhöhung der Fließgrenze bei ungleichmäßiger Spannungsverteilung, Biegekennlinien und die Bestimmung der oberen Fließgrenze.

St. Sztatecsny: Zeichnerische Ermittlung von Biegekennlinien, Einfluß von Eigenspannungen auf das Fließgrenzbild. Wien 1936, Julius Springer.

² *Rinagl*: Akad. Anzeiger 12 und 18 Akademie der Wissenschaften in Wien. Sitzung 4. 7. 1935 und 14. 5. 1936.

³ *A. Kennedy*: Exp. on the yield point of steel under transverse test. Engg. 115 (1923), p. 736.

⁴ *O. Eiselin*: Untersuchung am einfach gelochten Zugstab, Beitrag zum Problem der Spannungsstörungen in Eisenbauten (Tensile tests on simply perforated bar; treatise on the problem of stress disturbances in steelwork). Bauingenieur 1924, p. 250.

⁵ *W. Scoble*: Reinforcement by understressed material. Engg. 123 (1927), p. 65.

⁶ *G. Bierett*: Mitteilung der deutschen Materialprüfanstalt, Special Issue XV, 1931.

⁷ *Nakanishi*: Rep. Aeron. Res. Inst. Tokio, 1931, p. 83.

⁸ *A. Thum* and *F. Wunderlich*: Die Fließgrenze bei behinderter Formänderung (Restricted deformation and the yield limit). Forschung auf dem Gebiete des Ingenieurwesens, 1932, p. 261.

⁹ *O. Cook*: The yields Point an initial stages of plastic strain in mild steel subjected to uniform an non-uniform stress distributions. Phil. Transact. Roy. Soc. London, Ser. A 230 (1932), Nr. 4, p. 121.

¹⁰ *W. Prager*: Die Fließgrenze bei behinderter Formänderung (Restricted deformation and the yield limit). Forschung auf dem Gebiete des Ingenieurwesens, 1933, p. 95.

¹¹ *W. Kuntze*: Ermittlung des Einflusses ungleichförmiger Spannungen und Querschnitte auf die Streckgrenze. Der Stahlbau 1933, p. 49.

¹² *Chwalla*: Über die Erhöhung der Fließgrenze in prismatischen Balken aus Baustahl (The raising of the yield limit in prismatic beams of building steel). *Der Stahlbau*, 1933, p. 149.

¹³ *Siebel and Vieregge*: Abhängigkeit des Fließbeginns von Spannungsverteilung und Werkstoff (Dependence of start of yield on distribution of stresses and on material). *Archiv für Eisenhüttenwesen* 7 (1933/34), Issue 12, p. 679/82.

¹⁴ *Hessler*: Dissertation Stuttgart 1934, zitiert von *O. Graf*, Dauerversuche mit Nietverbindungen, p. 49, *Berichte des Ausschusses für Versuche im Stahlbau*, Edition B., Issue 5, Berlin 1935, Springer.

¹⁵ *Eugen Meyer*: Berechnung der Durchbiegung von Stäben, deren Material den Hooke'schen Gesetzen nicht folgt (Calculation of the deflection of rods whose material does not follow Hooke's laws). *Z.V.D.I.* 1908, p. 167.

¹⁶ *Moser*: Grundsätzliches zur Streckgrenze (Fundamental comments on the yield limit theory), *Forschungsarbeiten d. V.D.I.*, Issue 295.

¹⁷ *Ludwik-Scheu*: Über Kerbwirkungen bei Flußeisen, *Stahl und Eisen* 1923, Issue 32.

¹⁸ *Lode*: *Forschungsarb. a. d. Gebiete des Ing.-Wesens* 1928, Issue 303.

¹⁹ *Roš et Eichinger*: *Versuche zur Klärung der Bruchgefahr*, Zürich 1926.

²⁰ *Hartmann*: Zur Theorie und Ausführung der Hängebrücken. *Z. d. Österr. Ing.- und Arch.-Ver.* 1934, Issue 51/52, p. 293.

²¹ *Wagner*: Über den Umbau der Reichsbrücke in Wien. *Z. d. Österr. Ing.- und Arch.-Ver.* 1935, Issue 1, p. 1.

²² *Hencky*: Zur Theorie der plastischen Deformation (The theory of plastic deformation), *Zeitschrift f. angew. Math. u. Mech.* 1924, p. 323.

²³ *Klöppel*: Aus d. techn. wiss. Tätigkeit d. Deutschen Stahlbau-Verbandes (The activities of the German Steel Construction Federation). *Stahlbau* 1935, Issue 4.

²⁴ *Fritsche*: Tragfähigkeit von Balken aus Stahl mit Berücksichtigung des plastischen Formänderungsvermögens (Carrying capacity of steel beams, taking plastic deformability into consideration). *Bauingenieur* 1930, p. 851.

²⁵ *Ludwik and Scheu*: Über die Streckgrenze von Elektrolyt- und Flußeisen (The yield limit of electrolytic and mild steel). *Werkstoffausschußbericht No. 7 des Vereins Deutscher Eisenhüttenleute*.

²⁶ *Körber-Pomp*: Einfluß der Form des Probestabes, der Art der Einspannung, der Versuchsgeschwindigkeit und der Prüfmaschine auf die Lage der oberen und unteren Streckgrenze von Stahl (Influence of the shape of bar, type of restraint, speed of test and the test machine on the height of the upper and lower yield point of steel). *Publication of the Kaiser Wilhelm Institute for Steel Research*, 1934, p. 179.

²⁷ *Rinagl*: Neue Zugprobestabformen und Einspannvorrichtungen (New shapes of test bar and restraining devices for tensile tests). *Maschinenbau* 1923/24, p. 770.

²⁸ *Kollbrunner*: Schichtweises Fließen in Balken aus Baustahl (Flowing within successive layers in steel beams). *Publications of the I.A.B.St.E.*, Vol. 3, 1935, p. 222.

²⁹ *Preuss*: Versuche über die Spannungsverteilung in gekerbten und gelochten Zugstäben (Tensile tests on the distribution of stresses in notched and perforated bars). *Z.V.D.I.* 1912, p. 1349, 1780 and 1913: p. 664, and *Forschungsarb. Ing.Wes.* Nr. 126.

³⁰ *O. Lasche*: *Konstruktion und Material im Bau von Dampfturbinen und Turbodynamos* (Construction and building material for steam turbines and turbo-dynamos) Springer, Berlin 1920, p. 56.

³¹ *Chwalla*: Letter to the Editor of *Stahlbau*, 1936, p. 8.

³² *Thum*: Die „Gestaltfestigkeit“ der Einfluß der Form auf die Festigkeitseigenschaften. *Schweiz. Bauzeitung*, vol. 106 (1935), p. 26, fig. 4.

³³ *Klöppel*: Bestimmung der Schwellzugfestigkeit voller, gelochter und genieteteter Stäbe aus St 37 und St 52. *Stahlbau* 1936, p. 109, fig. 37.

Summary.

In the past ten years various scientists have observed marked increases in the height of the yield limit of steel under unequally distributed stressing. This increase they have attempted to explain as being due to restrained deformation. The various causes from which this fallacy arose are the following:

- 1) When the stressing is unequally distributed the whole yield range of the material may be exhausted at one point without a corresponding offset becoming apparent in the aggregate deformation curve in the case of bending, etc. An offset of this kind may, however, occur when for instance the sections subjected to bending have attained the plastic range almost to the depth of the neutral axis. The mistake was then made of employing the bending moment now present for the calculation of the stress for initial yielding on the equation $\sigma = M/W$. On this principle only the lower yield limit can be approximately calculated on the equation $\sigma = \frac{M}{2S}$ which is valid for the entirely plastic state.
- 2) The whole gradual transition of the deformation line from a straight line governed by *Hooke's* law to the elastic-plastic range for bending, torsion, a perforated bar, etc., makes the exact determination of the yield limit extremely difficult under certain circumstances.
- 3) Nor can the yield limit be safely determined by measuring the permanent deformations after under repeated loading and unloading, for the great plastic deformations set up in a small zone are almost entirely cancelled by the strong elastic reactions of the remaining portions of the test piece (apparent elasticity at the peaks of elongation, especially in the case of eye bars).
4. The occurrence and the length of yield lines are not a sure sign that the technically significant yield limit has been exceeded.
- 5) Any upper yield limit the material may have cannot be determined with certainty by the tensile test procedure in use up to now. The upper yield limit, which may lie more than 50% above the lower yield limit, is a real property of the material, acts almost without disturbance in bending tests and under certain circumstances can be the cause of labile processes.
- 6) The calculation of stresses from elongation measurements in three directions (elongation ellipse) is only permissible when the test piece is free from self-stresses caused by pre-treatment, i. e. when the interior forces (elastic forces) existing in the system are known.

The theory which assumes a gradual transition from the purely elastic state of stressing to the elastic-plastic states, and in certain circumstances to the purely plastic state, is confirmed by recent tests and appropriate interpretation of those already carried out. A rise in yield limit does not occur, though in certain cases a regular drop in the upper yield limit takes place. The equations derived for "characteristic bending lines" for various cross sections enable the elongation and deflection measurements to be checked and the upper yield limit of the material to be determined.