

Experiments on tubular beams of centrifugally cast concrete

Autor(en): **Král, A.**

Objektyp: **Article**

Zeitschrift: **IABSE congress report = Rapport du congrès AIPC = IVBH
Kongressbericht**

Band (Jahr): **2 (1936)**

PDF erstellt am: **06.08.2024**

Persistenter Link: <https://doi.org/10.5169/seals-3271>

Nutzungsbedingungen

Die ETH-Bibliothek ist Anbieterin der digitalisierten Zeitschriften. Sie besitzt keine Urheberrechte an den Inhalten der Zeitschriften. Die Rechte liegen in der Regel bei den Herausgebern.

Die auf der Plattform e-periodica veröffentlichten Dokumente stehen für nicht-kommerzielle Zwecke in Lehre und Forschung sowie für die private Nutzung frei zur Verfügung. Einzelne Dateien oder Ausdrucke aus diesem Angebot können zusammen mit diesen Nutzungsbedingungen und den korrekten Herkunftsbezeichnungen weitergegeben werden.

Das Veröffentlichen von Bildern in Print- und Online-Publikationen ist nur mit vorheriger Genehmigung der Rechteinhaber erlaubt. Die systematische Speicherung von Teilen des elektronischen Angebots auf anderen Servern bedarf ebenfalls des schriftlichen Einverständnisses der Rechteinhaber.

Haftungsausschluss

Alle Angaben erfolgen ohne Gewähr für Vollständigkeit oder Richtigkeit. Es wird keine Haftung übernommen für Schäden durch die Verwendung von Informationen aus diesem Online-Angebot oder durch das Fehlen von Informationen. Dies gilt auch für Inhalte Dritter, die über dieses Angebot zugänglich sind.

IIc 6

Experiments on Tubular Beams of Centrifugally Cast Concrete.

Versuche mit Schleuderbeton-Rohrbalkenträgern.

Essais effectués sur des poutres tubulaires en béton centrifugé.

Dr. Ing. A. Král,

Professor der techn. Fakultät an der Universität Ljubljana.

In the summer of 1936 a large job was completed in the Yugoslavian textile mills at Duga Resa near Karlovac (Banat of Save), in which roof girders took the form of pipe beams made of centrifugal concrete. The arrangement of the roof construction may be seen in Fig. 1. The opportunity was seized to make several series of exhaustive experiments at the materials testing station of the University of Ljubljana on differently designed and differently reinforced pipe beams.

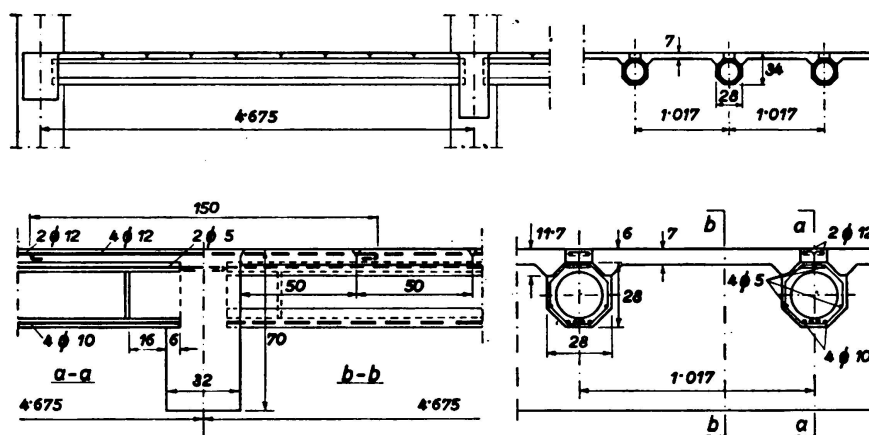

Fig. 1.

The pipes were made in three different shapes, namely:

- 1) an octagonal form as in Fig. 2a with a constructional depth of 28 cm;
- 2) the same form with a constructional depth of 22 cm; and
- 3) a polygonal form widened in the tension zone as shown in Fig. 2b.

Individual pipes, intended for heavy isolated loads, were provided with transverse stiffeners at the load points and at the supports, in order to prevent premature damage through the pipe collapsing.

As shown in Fig. 2 the reinforcement consists of four bars of 5 mm diameter in the upper and middle corners and tensile reinforcement in the lower side, in addition to spiral hooping of steel wire 3 mm in diameter fixed by the con-

tractor which (with the exception of pipe 17 and pipe 18) was welded to the compression and tensile reinforcements at particular points.

The following materials were used for the reinforcements:

- 1) Structural steel C 37 obtained from the Kranjska Industrijska Družba at Jesenice (corresponding to the German steel St. 37).
- 2) Isteg steel, supplied by the same firm.

The pitch of the spiral hooping was made variable, and in places two spirals were used.

High grade Portland cement of the "Stockbrand" mark, supplied by the Portland cement factory at Split, was used for all the pipes. The aggregate consisted partly of limestone of 13 mm gauge, obtained from the quarries of the

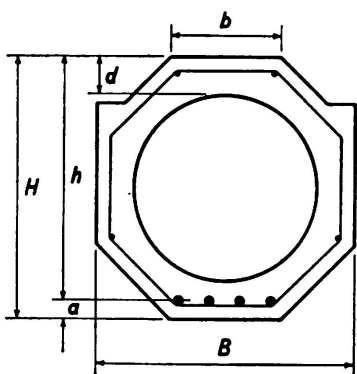

Fig. 2 a.

Beams Nos. 1 to 12, 17 to 22, I to III.

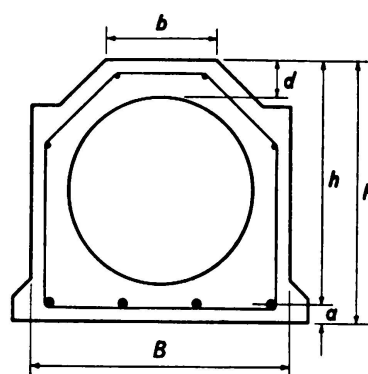

Fig. 2 b.

Beams Nos. 13 to 16.

textile works at Duga Resa, and partly gravel and sand taken from the Save-river, up to 13 mm in gauge.

The following three mixes were used:

- 1) Broken limestone with 410 kg of cement per cubic metre of finished concrete, water cement ratio 0.45—0.515.
- 2) Save gravel and sand with 410 kg of cement per cubic metre of finished concrete, water cement ratio 0.45—0.50.
- 3) Broken limestone with 300 kg of cement to one cubic metre of finished concrete, water cement ratio 0.69—0.72.

The reinforcing steel C 37 showed mechanical properties considerably better than the minima laid down in the standard. Its yield point varied on an average between 29.52 and 33.07 kg/mm²; the tensile strength between 40.41 and 42.43 kg/mm²; the specific elongation at fracture, in a gauge length of ten diameters, between 27.3 and 40.7 %.

The Isteg steel had an ultimate strength of 44.7 to 47.4 kg/mm², an elastic limit of 37.9 to 40.3 kg/mm² for 4 % elongation, and an elongation of breakage of 5.5 to 8.5 %.

The average strength of the different kinds of concrete at an age of four weeks may be seen from the following table:

Nature of aggregate	Cement kg per m ³ of concrete	Cube strength per kg/cm ²	Tensile bending strength per kg/cm ²
Broken limestone . . .	410	630	62.3
Save gravel and sand . .	410	585	56.9
Broken limestone . . .	300	639	54.4

The test specimens were prepared not in the laboratory but on the job, and the dates of production are those given by the supervisors of the work. In the laboratory exact dimensions and weights were recorded, and in the case of the pipe beams which were tested to destruction the reinforcement was afterwards exposed and remeasured.

The investigation extended to 21 series of variously designed types of beam, each represented by two samples, so that altogether it covered 42 pipe beams, from which only a few characteristics results will be given below.

Fig. 3 shows the relationship between the breaking moment and the amount of tensile reinforcement, using the normal round steel C 37 and the Isteg steel, for two different types of beam of 28 and 22 cm depths respectively.

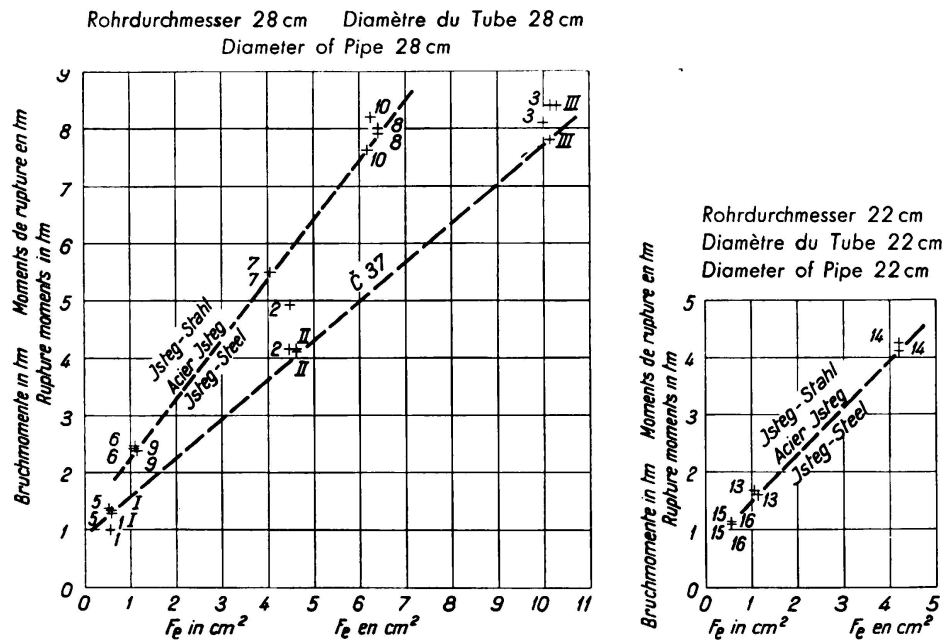

Fig. 3.

In this summary the great uniformity (or small amount of scattering) of the experimental results is apparent, and this is true not only as regards individual pairs of beams but also as regards the uniform increase in breaking moment according to the reinforcement provided.

In order to show details of the experiments, and the kind of results obtained, the following is a table of the results for six characteristic beams

with weak, medium and strong tensile reinforcement respectively, both with round steel C 37 and with Isteg steel.

No.	Reinforcement			Bending moment		Calculated steel stress at fracture
	Type of steel	ϕ	Area	at cracking	at fracture	
		mm	cm ²	tonne-metres	tonne-metres	kg/cm ²
5	C 37	2 ϕ 6	0.58	0.78	1.29	9460
2	„	4 ϕ 12	4.48	1.79	4.16	4205
3	„	4 ϕ 18	9.99	3.32	8.10	3883
6	Isteg	2 \odot 6	1.08	0.82	2.43	9490
7	„	4 \odot 8	4.07	1.79	5.49	5885
8	„	5 \odot 10	6.41	2.66	7.91	5575

The summary shows that in the case of the lightly reinforced beams no cracking appeared under a load equal to half the working load, and the same result was obtained in the other series of experiments. In beams containing heavier reinforcement, or in those with Isteg reinforcement, fine cracks made their appearance earlier; but under a load equal to half the breaking load the distribution of these fine cracks was in one series within the region of the maximum bending stresses, and when the load was removed they closed up again so as to be scarcely perceptible with the naked eye. Open cracks did not appear until fracture.

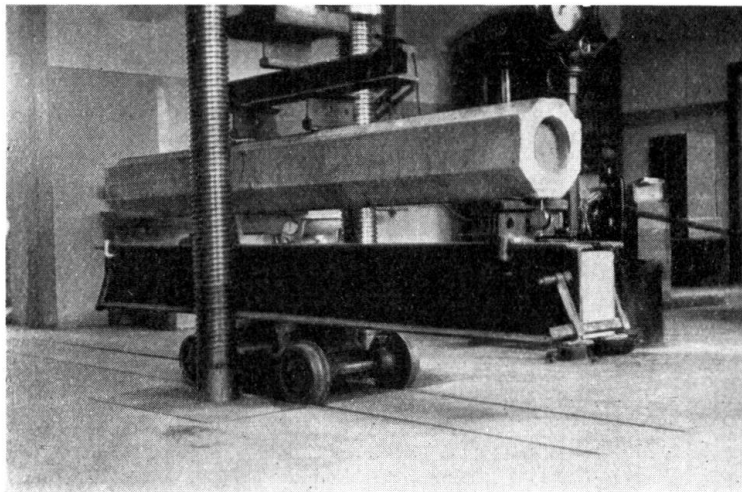

Fig. 4.
Arrangement of experiments.

In the case of the lightly reinforced pipes only tensile cracks were visible, even in the breaking condition. With the heavier tensile reinforcement and single spiral hooping shear cracks arose which in some cases spread into pipe-bursting-cracks or combined with the latter. With the heavier hooping a bulging of the concrete occurred in the compression zone, usually in the neighbourhood of the load point. With lighter hooping, failure occurred by bursting of the pipes, especially in the case of the pair of pipes marked "1" (Fig. 3).

The steel stresses given in the table, which were calculated on the assumption of a modular ratio of 10 as for Condition II, indicate that — especially in the case of lightly reinforced beams — the theoretical steel stresses assume illusory values. This is attributable to the fact that in these beams (even when in the breaking condition) the concrete in the tension zone continues to co-operate very considerably in spite of its continuity being impaired by cracks. The heavier the reinforcement the more closely did the calculated stress in the steel just before fracture approximate to the yield point of the reinforcement.

Measurements of bending under repeated loading show excellent elastic performance in addition to the normal phenomena of plasticity; hence the classical

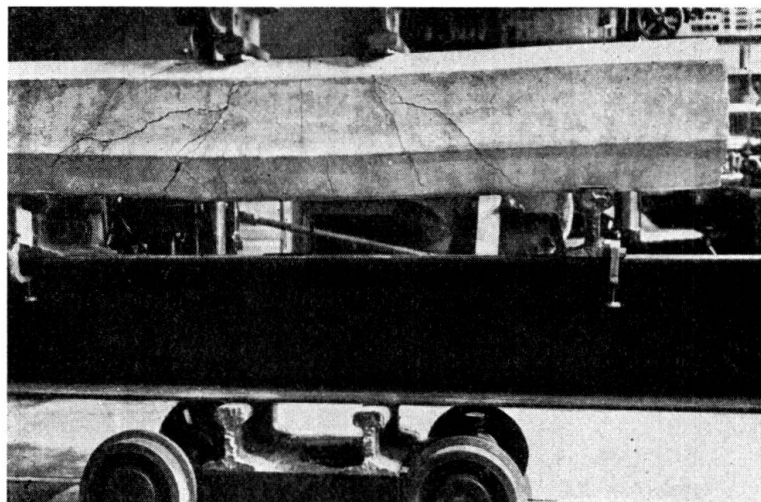

Fig. 5.

Cracks resulting from combined shear and crushing of tube.

theory of elasticity may be used for determining the stresses and strains in beams of this kind. As in all reinforced concrete work it is mainly a question of the correct assumption of elastic constants. As regards bending stresses some amplification or correction of the classical *Bernoulli-Navier* theory of bending would appear, if possible, to be desirable, but in any case there are no insuperable difficulties in determining the stresses at the most dangerous points by reference to the elasticity theory with sufficient approximation, and where pipe beams are to be built up as here into a three-dimensional system this is especially important. The fact that the results of calculations made by assuming a linear condition of stress should differ greatly from the true conditions determined by a three-dimensional elasticity-tensor field is no more than logical, and is illustrated in the results given above.

The great uniformity of the test results is doubtless attributable to the concrete being exceptionally dense and regular, as could be observed at the fractures. These properties, which have been found in a considerable number of beams produced under factory conditions, go to show that the centrifugal process — already long in use for making transmission poles and pressure pipes — may rationally be applied to the production of load bearing beams also, provided that careful workmanship can be counted upon.