

**Zeitschrift:** IABSE congress report = Rapport du congrès AIPC = IVBH  
Kongressbericht

**Band:** 2 (1936)

**Artikel:** Stress and distortion due to welding

**Autor:** Heigh, W.

**DOI:** <https://doi.org/10.5169/seals-3283>

### **Nutzungsbedingungen**

Die ETH-Bibliothek ist die Anbieterin der digitalisierten Zeitschriften. Sie besitzt keine Urheberrechte an den Zeitschriften und ist nicht verantwortlich für deren Inhalte. Die Rechte liegen in der Regel bei den Herausgebern beziehungsweise den externen Rechteinhabern. [Siehe Rechtliche Hinweise.](#)

### **Conditions d'utilisation**

L'ETH Library est le fournisseur des revues numérisées. Elle ne détient aucun droit d'auteur sur les revues et n'est pas responsable de leur contenu. En règle générale, les droits sont détenus par les éditeurs ou les détenteurs de droits externes. [Voir Informations légales.](#)

### **Terms of use**

The ETH Library is the provider of the digitised journals. It does not own any copyrights to the journals and is not responsible for their content. The rights usually lie with the publishers or the external rights holders. [See Legal notice.](#)

**Download PDF:** 13.10.2024

**ETH-Bibliothek Zürich, E-Periodica, <https://www.e-periodica.ch>**

## III b 2

### Stress and Distortion Due to Welding.

#### Schweißspannungen und Verwerfungen.

#### Contraintes internes et distorsions provoquées par la soudure.

W. Heigh,

Welding Superintendent, Babcock & Wilcox, LTD., Glasgow.

One is apt to glean from the leading papers in this discussion that welding in its present state is a very inexact science. There are too many doubts and fears — too many unknown factors.

Those of us who are concerned chiefly with getting work done cheaply, quickly and well, detest the unknown and avoid it at all costs.

Some reassurance seems to be necessary.

For example, the fear is expressed in one of the papers that the weld metal may be in a dangerously chilled condition and that it is liable to be dangerously stressed.

Since the weld metal obtained from certain good and quite cheap covered electrodes is consistently ductile, no real danger exists. An elongation of 22 to 25 % on a gauge length of four diameters is commonly obtained in the as-welded condition.

Dangerously chilled metal could not be so ductile, while with so much stretch left in the weld metal the stressed condition is much less important than it seems.

We are also warned to be careful of the stressed condition in the parent material — the metal in the pieces being joined together.

But rolled steel sections and mild steel plates are almost invariably cold straightened before being applied to important structures and are therefore in a stressed condition. Hundreds of very high self-supporting steel chimneys (that is, chimneys without guy-rope supports) sway in high winds over populous workshops and cities; yet no one thinks of excessive danger to life although all the plates have been cold rolled and therefore stretched far more than any weld-stretched piece of metal.

If inequality of stress distribution is feared, the analogy of hot bent rolled sections is a comfort. Those are used freely in important structures, yet the fact that most of the bends are made by local heating and forming leaves the metal in a condition precisely similar to that in a weld and the surrounding material.

Speaking practically, all those fears may easily be exaggerated. If a good electrode and a sound welding procedure are chosen and if the chilling effect

of large masses of material, very cold weather and weather-exposed welding positions are allowed for by slight preheating welding may be used with full confidence.

It is, of course, an advantage to relieve the stresses by heat treatment and in certain cases, notably in thick welded pressure vessels, stress relief is a normal part of the manufacturing procedure. Apart from the extremely high pressures frequently involved (a sufficient argument for special treatment) the stressed condition of the cold formed thick plates and the locked condition of many of the welds in pressure vessels are such as are seldom if ever met with in structural work.

From another point of view, the desire is general in design offices and workshops for quick safe rules for the control of distortion in the final shape of a structure. Some suggestions are offered by the leaders in this discussion. Possibly those which follow will add something of value. Distortion in those notes refers

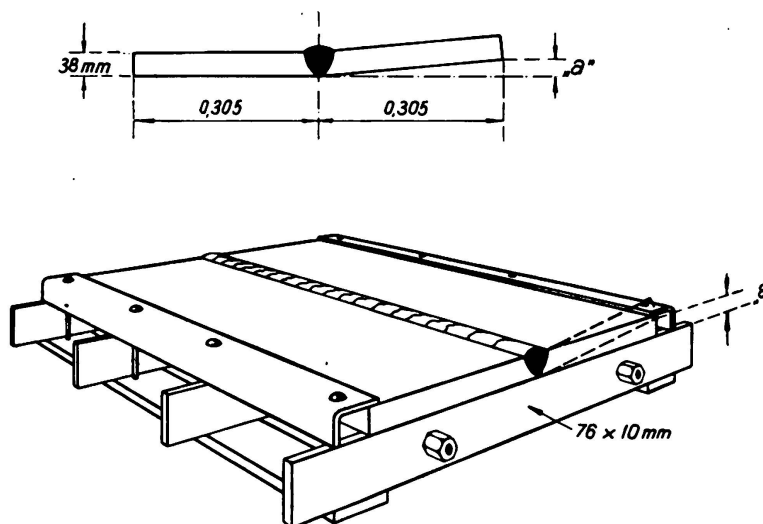

Fig. 1.

to the visible change of shape, not to the displacement within the material which is its root cause.

1) Clamping need not be rigid to be effective. For example, Figure 1 shows two test plates in position in a clamp designed to reduce the distortion. Welding the plates free, dimension "a" was 1" (25 mm). Welding the plates in the clamp, dimension "a" was reduced to  $\frac{3}{16}$ " (5 mm).

The moment of resistance of the clamp was one quarter that of a weld of plate thickness, or equal to the resistance of a plate one half the thickness being welded.

No resistance (except friction) was offered to the transverse contraction. This is deemed important.

The flats of mild steel were of such a length that the angular movement due to the shrinkage of each run of welded did not strain the flats beyond the elastic limit.

The principle of the clamp has many applications and has been used freely with success.

2) Size of electrode and method of deposit used are of importance.

Figure 2 illustrates three conditions in a butt weld.

- a) N° 8 w. g. electrodes (4 mm diameter) bead runs, gave an angular distortion of  $8^{\circ}$ .
- b)  $\frac{1}{4}$ " (6,3 mm) diameter electrodes, bead runs, gave an angular distortion of  $4^{\circ}$ .
- c)  $\frac{1}{4}$ " (6,3 mm) diameter electrodes, woven layers, gave an angular distortion of  $3^{\circ}$ .

A further test in a clamp gave an average angular distortion of only  $1^{\circ} 11'$ .

Tests a) and b) were repeated with fillet welds with somewhat similar results.

Large electrodes certainly reduce this very troublesome type of distortion. It is also important to add that welds a), b) and c) were all submitted to mechanical tests and met the requirements of the American Fusion Welding Code for Pressure Vessels so that in this sense the welds were of equal value.

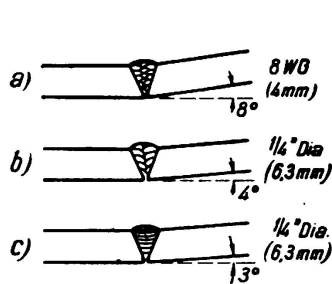

Fig. 2.

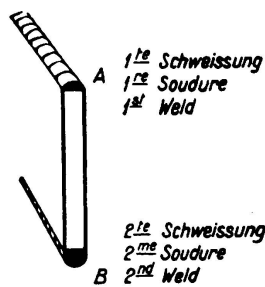

Fig. 3.

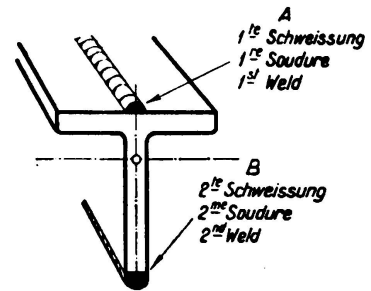

Fig. 4.

3) Rotation of welding assists in reducing distortion.

- a) Approximately equal effects are obtained by running two welds, placed symmetrically at an equal distance from the neutral axis of a symmetrical section, simultaneously.
- b) If a first run of welding distorts a symmetrical section, a first run of double the volume on the opposite side or edge will approximately balance the first distortion. Figure 3 illustrates a simple test to check this. In multiple run welds distortion from later runs requires a much greater opposing effect.
- c) The first in order of two welds in an asymmetrical section as illustrated on Figure 4 should be that nearest the neutral axis.

With training, assemblers and welders acquire considerable skill in checking and controlling distortion. For important non-recurring work, however, the assembly should be planned beforehand and a check kept as the work proceeds so that rotation of welding may be changed, as is found necessary, to correct distortion and keep the assembly in shape.