

# Structural welding in practice

Autor(en): **Fava, A.**

Objektyp: **Article**

Zeitschrift: **IABSE congress report = Rapport du congrès AIPC = IVBH  
Kongressbericht**

Band (Jahr): **2 (1936)**

PDF erstellt am: **11.07.2024**

Persistenter Link: <https://doi.org/10.5169/seals-3289>

## **Nutzungsbedingungen**

Die ETH-Bibliothek ist Anbieterin der digitalisierten Zeitschriften. Sie besitzt keine Urheberrechte an den Inhalten der Zeitschriften. Die Rechte liegen in der Regel bei den Herausgebern.

Die auf der Plattform e-periodica veröffentlichten Dokumente stehen für nicht-kommerzielle Zwecke in Lehre und Forschung sowie für die private Nutzung frei zur Verfügung. Einzelne Dateien oder Ausdrucke aus diesem Angebot können zusammen mit diesen Nutzungsbedingungen und den korrekten Herkunftsbezeichnungen weitergegeben werden.

Das Veröffentlichen von Bildern in Print- und Online-Publikationen ist nur mit vorheriger Genehmigung der Rechteinhaber erlaubt. Die systematische Speicherung von Teilen des elektronischen Angebots auf anderen Servern bedarf ebenfalls des schriftlichen Einverständnisses der Rechteinhaber.

## **Haftungsausschluss**

Alle Angaben erfolgen ohne Gewähr für Vollständigkeit oder Richtigkeit. Es wird keine Haftung übernommen für Schäden durch die Verwendung von Informationen aus diesem Online-Angebot oder durch das Fehlen von Informationen. Dies gilt auch für Inhalte Dritter, die über dieses Angebot zugänglich sind.

## III b 8

### Structural Welding in Practice.

Aus der Praxis der geschweißten Konstruktionen.

Sur la pratique des constructions soudées.

Dr. Ing. A. Fava,

Chef de Service aux Chemins de fer de l'Etat, Rome.

In Italy the use of welding has now become a matter of accepted practice in all branches of steel construction, but its application to bridges of large span still gives rise to notable difficulties. It is relatively easy, by adherence to the correct rules, to obtain welded joints which give the necessary strength even under the action of dynamic and repeated stresses, but difficulties arise as the result of the deformations which occur during the cooling of the seams in the construction of large bridges, and of the internal stresses which are thereby produced in the material. It has been found experimentally that these stresses may be very great.

If these deformations and the resulting internal stresses are to be avoided without the use of great thicknesses of material, it is necessary to adopt expedients and precautions which have the effect of considerably increasing the unit costs of welded work. Up to the present it has not been found, in Italy, that this increase in cost is compensated by a reduction in weight, so that under present conditions there is no economic advantage in using welding for large spans. The question is, however, receiving continued attention, in view of the emphasis that is being laid in Italy on the need to economise in steel, and it may be mentioned that preparatory work is now in hand among Italian steel makers for the production of special series of rolled sections which will facilitate welded work. These special sections will enable the deformations to be reduced, and it is anticipated that in this way an economic solution to the problem will be found.

On the State Railway system several bridges are in course of construction having plate-webbed main girders of spans up to 40 m which are completely welded. For still greater spans open-webbed bridges are preferred, wherein all the members including bracings are of welded construction, and only the site joints (including the connections between the web members and the booms) are rivetted.

Fig. 1 represents one of these bridges, and Fig. 2 shows one of its cross girders in course of being welded by means of an apparatus which enables it to be easily

and rapidly moved about, so that the sequence of weld seams can be arranged with a view to minimising the tendency to warping.

Despite every precaution, however, the contraction which occurred in the cross section of the weld seams while cooling resulted in the bottom of the girders

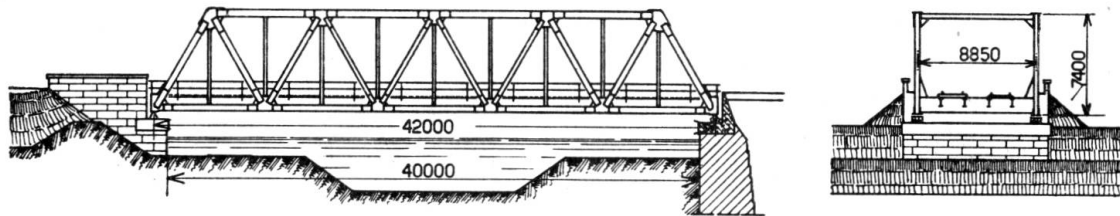

Fig. 1.

becoming bent, and at those points where (as for making the connections) it was essential that a perfectly flat undersurface should be obtained the only practicable remedy was found to be that of giving the plates to be used for the purpose a pre-imposed curvature in the opposite direction to that which would

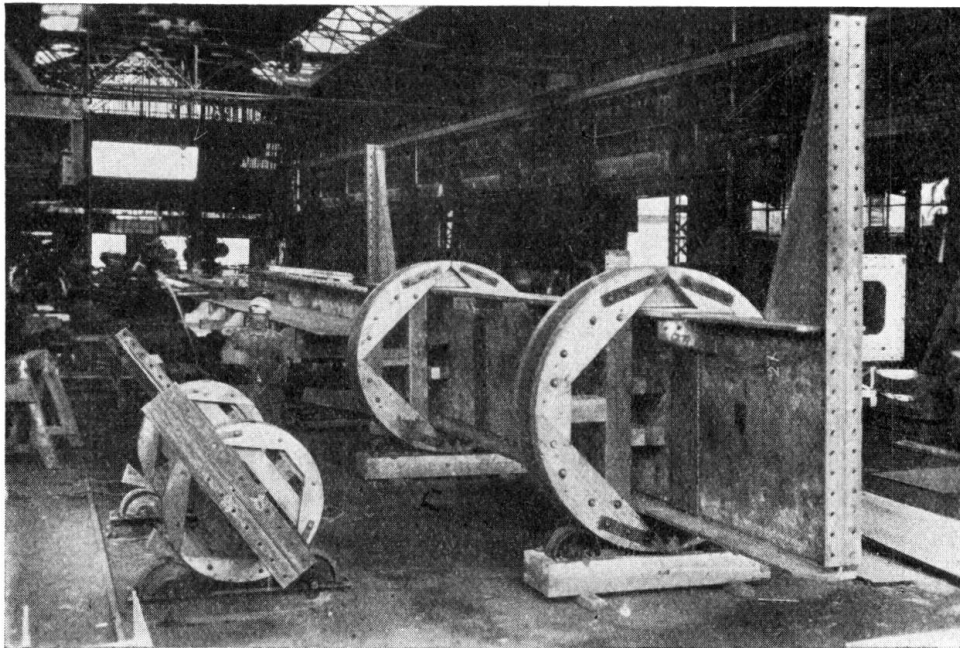

Fig. 2.

result from the cooling; an expedient which gives some idea of the costliness of the work.

Rather than enter into further details regarding these railway bridges, it is proposed to mention a few ordinary road bridges of completely welded construction, which, while of relatively limited size, may be of some interest as steps

towards more ambitious work. These bridges have openwebbed main girders, and welding is used even for the connections of the web members. It was found possible to choose the sections of the various members in relation to the



Fig. 3.

loads to be imposed upon them in such a way as to minimise the tendency to deformation.

Figs. 3 and 4 refer to a number of bridges over the Isorno torrent near Domodossola, wherein both the boom and the web members of the main girders are

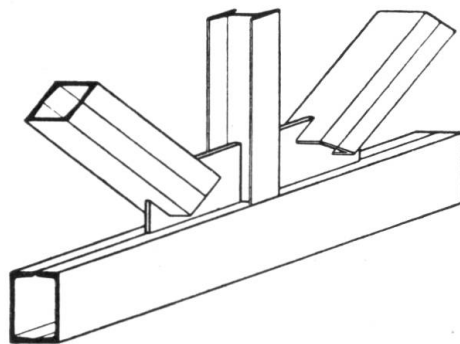

Fig. 4.

of tubular section built up by welding from two channel sections, slots being provided as in Fig. 4 for the insertion of connecting gussets.

Figs. 5 and 6 relate to two bridges of 25 m length over the Adige at Cengles. Here again the booms of the openwebbed main girders consist of double channel sections built up by welding. The diagonals consist of pairs of channel irons

connected by plates. The verticals are slotted and were formed by the use of the cutting flame to make suitable openings in I beams, separating the two parts so

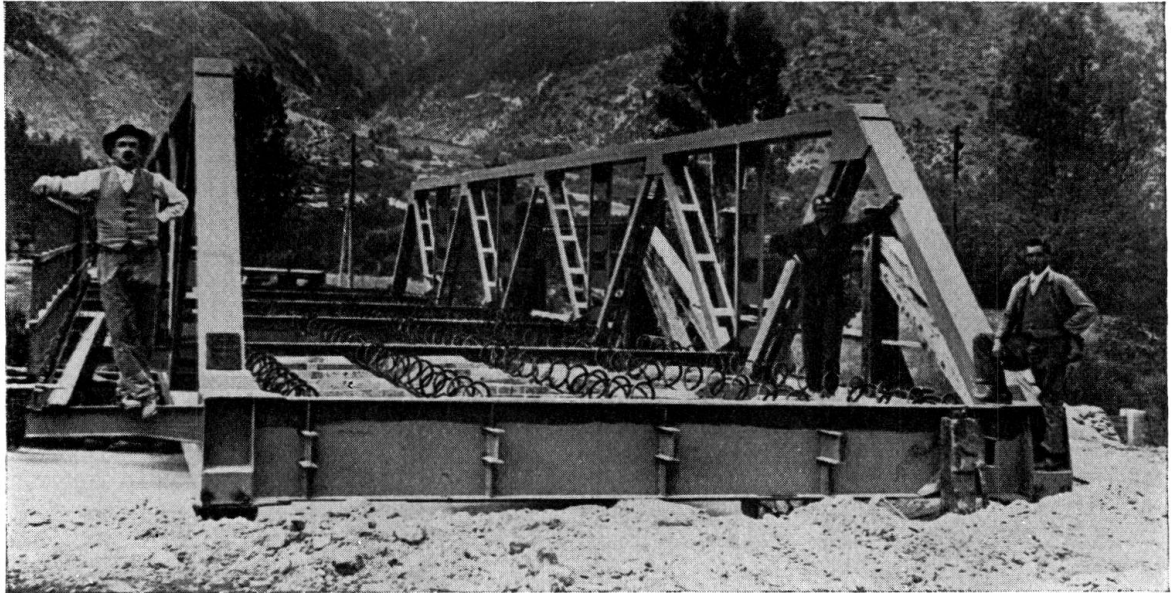

Fig. 5.

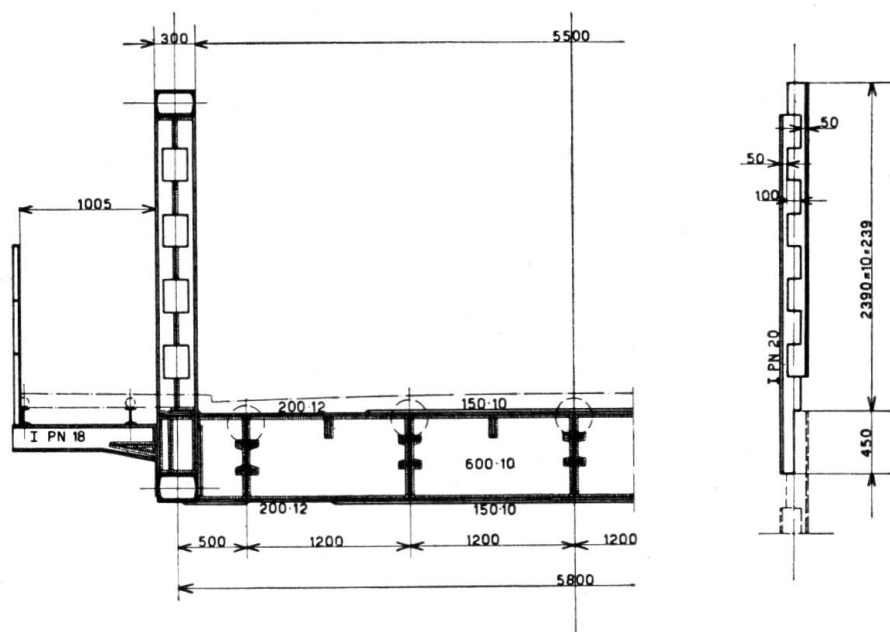

Fig. 6.

obtained and then welding the two projecting portions. The floor of the bridge consists of rolled beams of the well-known "Alpha" type, covered by a reinforced concrete slab.

Figs. 7 and 8 show a road bridge of 30 m span, in which the main girders are of solid-webbed construction and are reinforced above by a light arch in compression. The bridge gives a light and pleasing appearance and the whole of the booms are welded, including the end bearings.

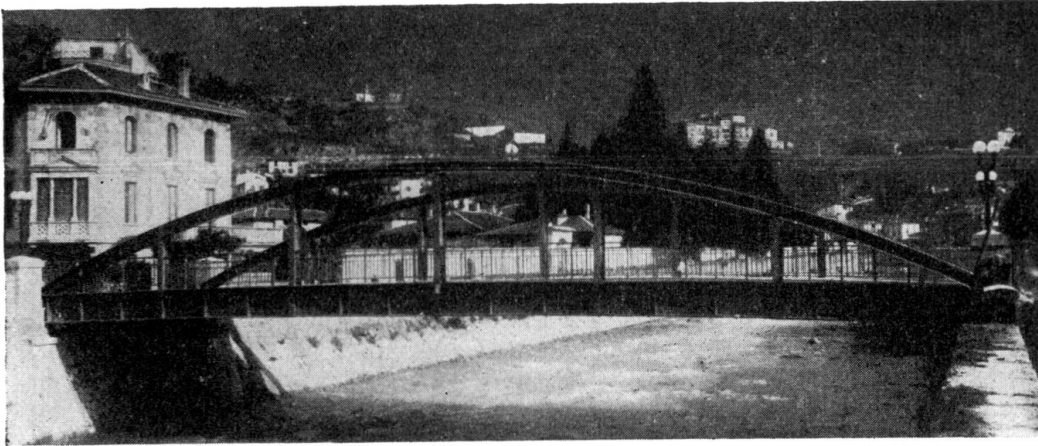

Fig. 7.

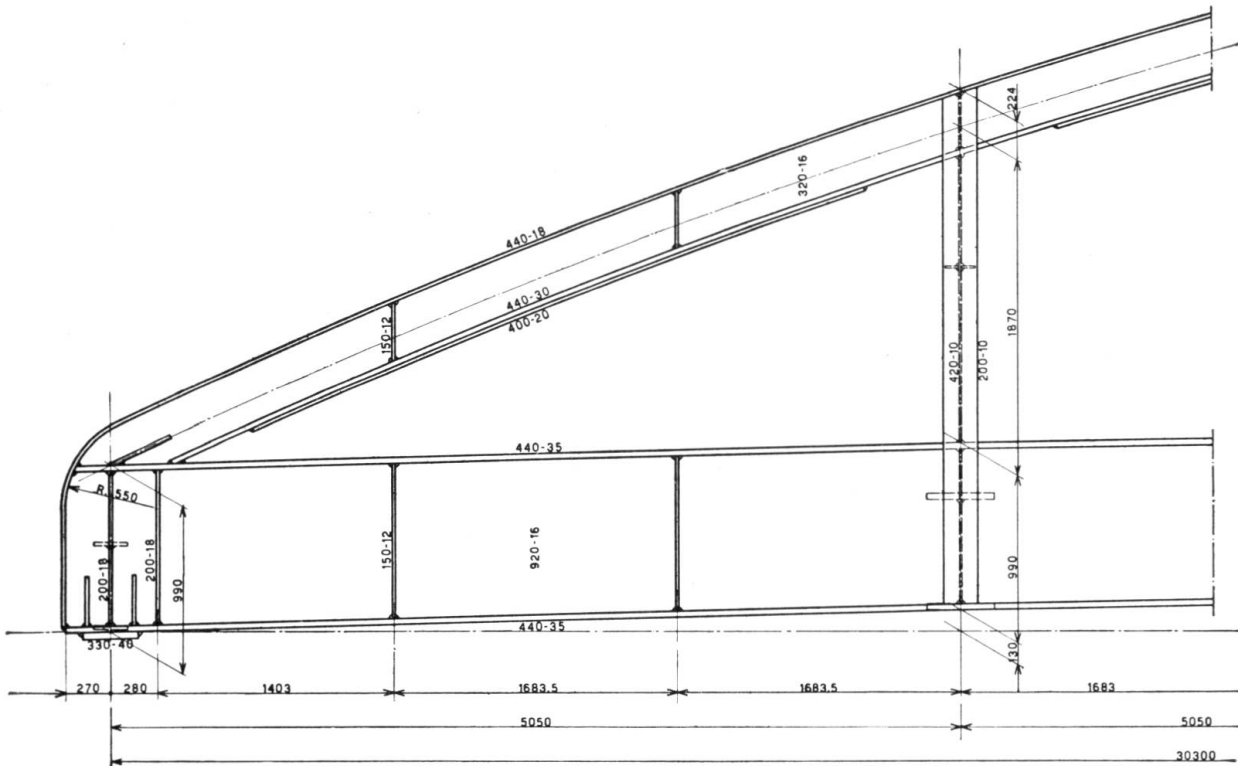

Fig. 8.

Leere Seite  
Blank page  
Page vide