

Applications of structural steelwork in Italy

Autor(en): **Fava, A.**

Objektyp: **Article**

Zeitschrift: **IABSE congress report = Rapport du congrès AIPC = IVBH
Kongressbericht**

Band (Jahr): **2 (1936)**

PDF erstellt am: **06.08.2024**

Persistenter Link: <https://doi.org/10.5169/seals-3346>

Nutzungsbedingungen

Die ETH-Bibliothek ist Anbieterin der digitalisierten Zeitschriften. Sie besitzt keine Urheberrechte an den Inhalten der Zeitschriften. Die Rechte liegen in der Regel bei den Herausgebern.

Die auf der Plattform e-periodica veröffentlichten Dokumente stehen für nicht-kommerzielle Zwecke in Lehre und Forschung sowie für die private Nutzung frei zur Verfügung. Einzelne Dateien oder Ausdrucke aus diesem Angebot können zusammen mit diesen Nutzungsbedingungen und den korrekten Herkunftsbezeichnungen weitergegeben werden.

Das Veröffentlichen von Bildern in Print- und Online-Publikationen ist nur mit vorheriger Genehmigung der Rechteinhaber erlaubt. Die systematische Speicherung von Teilen des elektronischen Angebots auf anderen Servern bedarf ebenfalls des schriftlichen Einverständnisses der Rechteinhaber.

Haftungsausschluss

Alle Angaben erfolgen ohne Gewähr für Vollständigkeit oder Richtigkeit. Es wird keine Haftung übernommen für Schäden durch die Verwendung von Informationen aus diesem Online-Angebot oder durch das Fehlen von Informationen. Dies gilt auch für Inhalte Dritter, die über dieses Angebot zugänglich sind.

VII a 3

Applications of Structural Steelwork in Italy.

Die Verwendung des Stahls beim Bau von Stahlkonstruktionen
in Italien.

L'application de l'acier aux constructions métalliques
en Italie.

Dr. Ing. A. Fava,

Chef de Service aux Chemins de fer de l'Etat, Rome.

1) It will be appreciated that in Italy the shortage of ore and coal render steel a very expensive material, and that its applications are consequently limited to those cases where it is an absolute necessity or offers special advantages by comparison with other materials, leaving many fields in which it is unable to compete against its rival, reinforced concrete.



Fig. 1.

2) One of the fields in which it is generally necessary to make use of steel is that of railway bridges which, frequently, are too low in height for the development of masonry arches or reinforced concrete structures. The Italian

State Railways system includes some 7000 steel bridges having a total length of nearly 100 km and during the last ten years about one third of these bridges have been renewed, a process which has usually involved the replacement of the existing spans by new ones except in the case of those of less than 10 m.

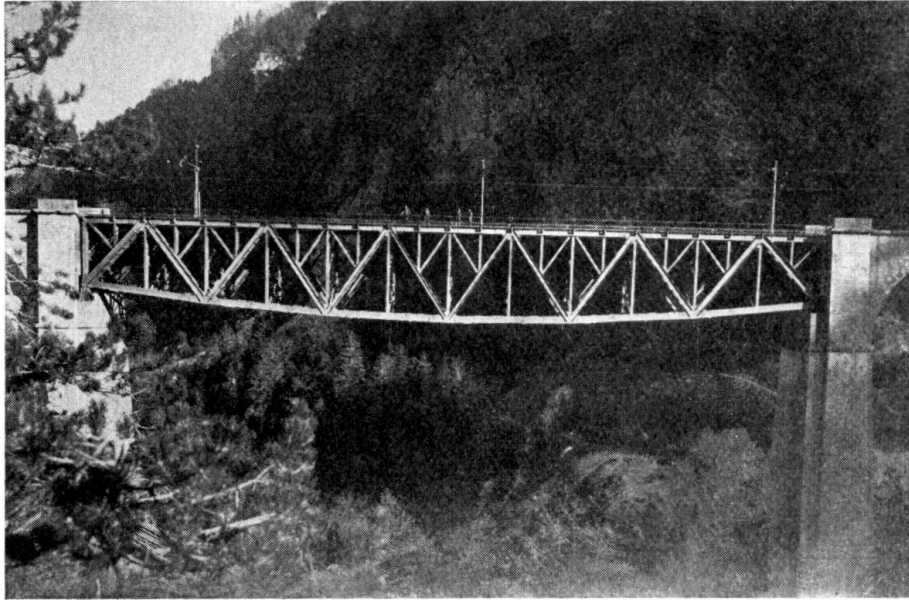

Fig. 2.

Fig. 1 shows a girder over three spans which may be considered as typical of recent work as regards constructional details. It will be seen that all the members consist of large section without small lattice work. The absence of the latter gives an effect of repose and great simplicity.

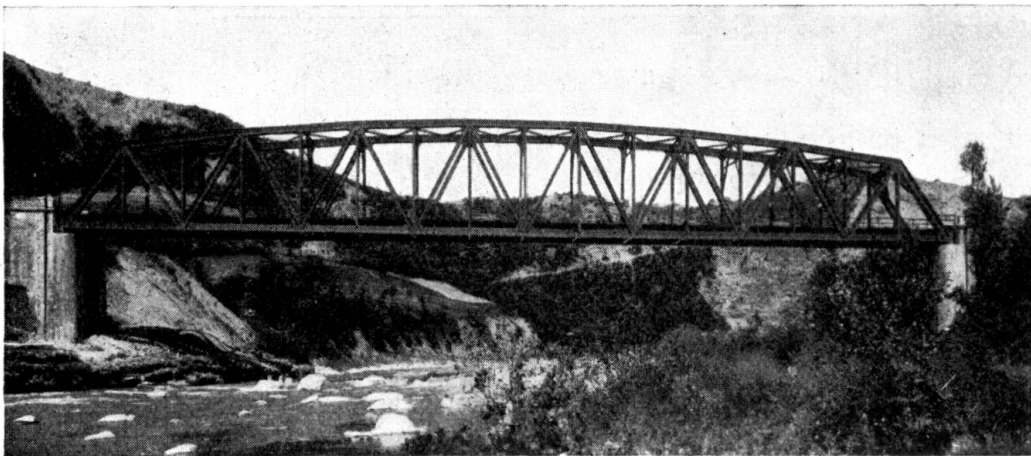

Fig. 3.

Fig. 2 shows one of the larger types of lattice bridges having a parabolic lower boom, and Fig. 3 a through span of about 90 m, again with a parabolic boom, which is representative of a great many bridges. Fig. 4 illustrates a continuous girder over two openings of 77 m each, with the exceptional feature

of intersecting diagonals in the main girders, this being adopted here as the most suitable arrangement in view of the bridge being very much on the skew.

In reference to this bridge it may be observed that for some time past the State Railways have abandoned the use of the continuous type of girder as it was found that in practice many such bridges underwent notable settlement of the supports, which seriously disturbed the distribution of forces. The continuous type is now again being adopted, but is made subject to careful

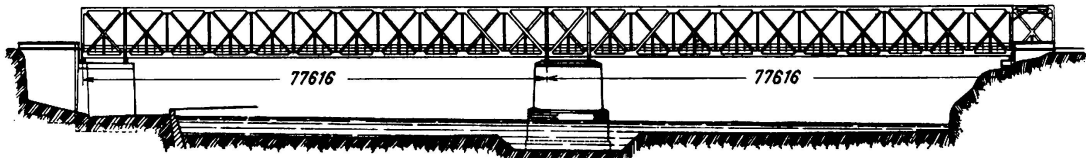

Fig. 4.

check of the levels of the supports. This is done with the aid of calibrated hydraulic jacks and precision manometers, whereby the span is lifted simultaneously from all of its supports and the respective reactions are adjusted to correspond with their theoretical values. In this way not only is it possible so to control the reactions that their values correspond to the several supports being on a level, but as an alternative it is possible to ensure experimentally,

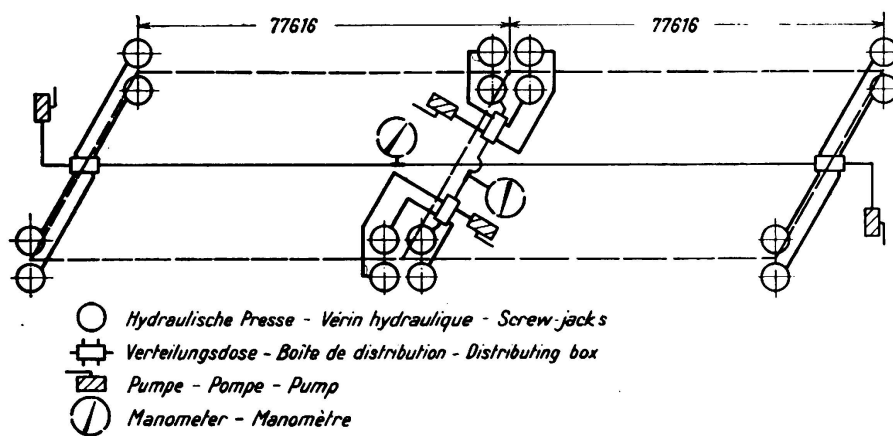

Fig. 5.

with every confidence, that the reactions assume any other values that may be the most expedient in order to obtain the greatest possible economy in the structure.

Fig. 5 shows diagrammatically the arrangement for setting the adjustment of these supports of the continuous girder illustrated in Fig. 4. The operation was combined with measurements of the stresses existing in different members of the structure, and it was found that had the adjustment not been made the reactions would have been very unfavourably influenced.

3) A very large number of public halls, varying in type, have been built entirely in steel, as well as steel framed buildings and roofs for civil, industrial and military purposes, during recent years. In this field of work welding,

especially electric arc welding, has fully established its position in Italy to such an extent that it may be expected in the course of a few years entirely to supersede the use of riveting.



Fig. 6.

From among the many examples which might be mentioned here we will take the steel roofs of the new railway station at Florence, which, at the same time, is a notable instance of modern welded construction.

These roofs are divided into two groups. The first of the latter, which covers the approach for motor cars and the booking hall, forms a structurally separate entity (Figs. 6 and 7). The supporting structure consists of eight large portal

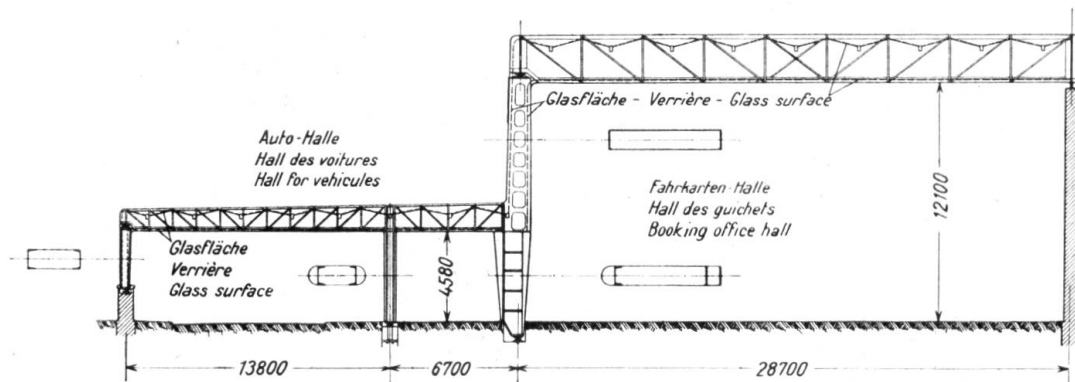

Fig. 7.

frames of three spans each, connected to one another by hinges in order to allow of thermal expansion. These carry two glass coverings, the outer one containing wire mesh glass and the inner one of Thermolux glass, both of them continuous horizontally and vertically, which gives a notable decorative effect. Between them are arranged the sources of artificial lighting for use at night. The outer glazing where it forms the roof has generally to be flat for architectural reasons, but to facilitate drainage it is built up of small elements slightly inclined to one another.

The second set of roofs at Florence is over the platforms and track (Figs. 8

and 9). Here the carrying frame consists of a series of large plate webbed girder spans of 30 m of varying double T section, built up of flat plates by welding.



Fig. 8.

For architectural reasons the shape of these girders is very special. They comprise three portions which are practically horizontal but at different levels, and are connected by steeply inclined portions. In view of the unusual shape

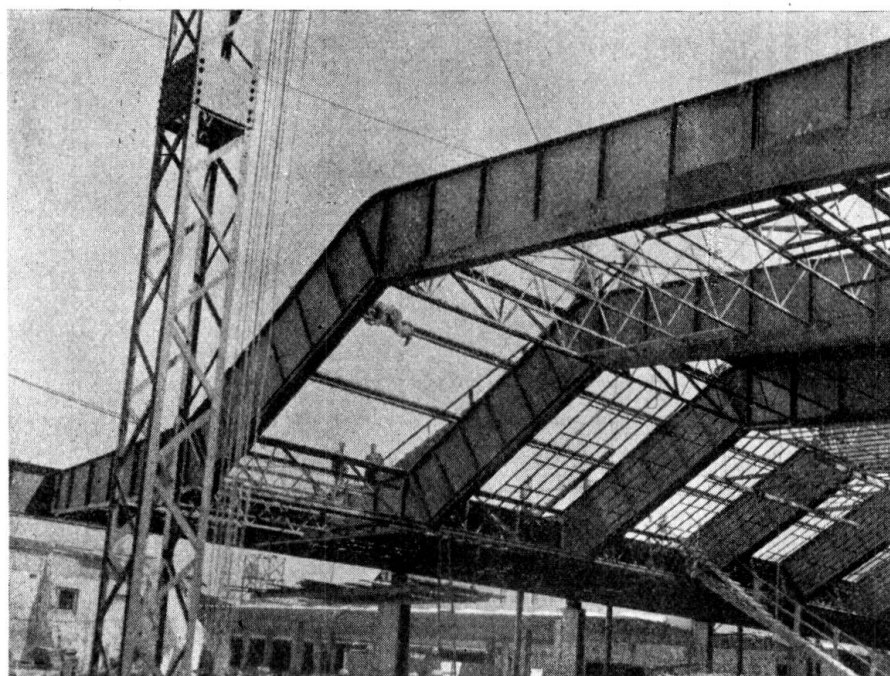

Fig. 9.

of these members their dimensions were decided after preliminary experiments on models, and after the work was completed they were made the subject of an accurate experimental investigation. All the visible portions of the steelwork at Florence have been copper coated and then burnished.

Another example of roofing is that over the public swimming baths at Milan (Fig. 10) which is notable also for the fact that a reinforced concrete construction was at first contemplated but that steel was preferred in view of

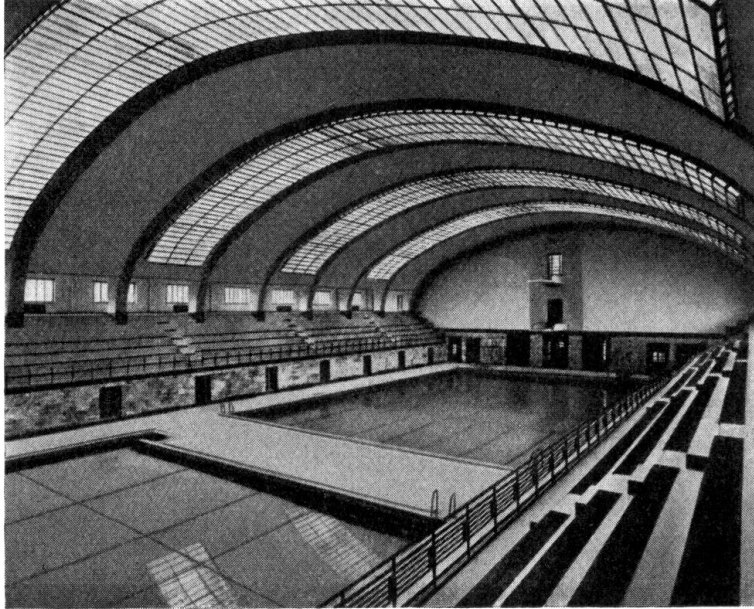

Fig. 10.

the very limited time available for carrying out the work. The arrangements for opening the glazed roof by remote control are ingenious, but these cannot be described here.

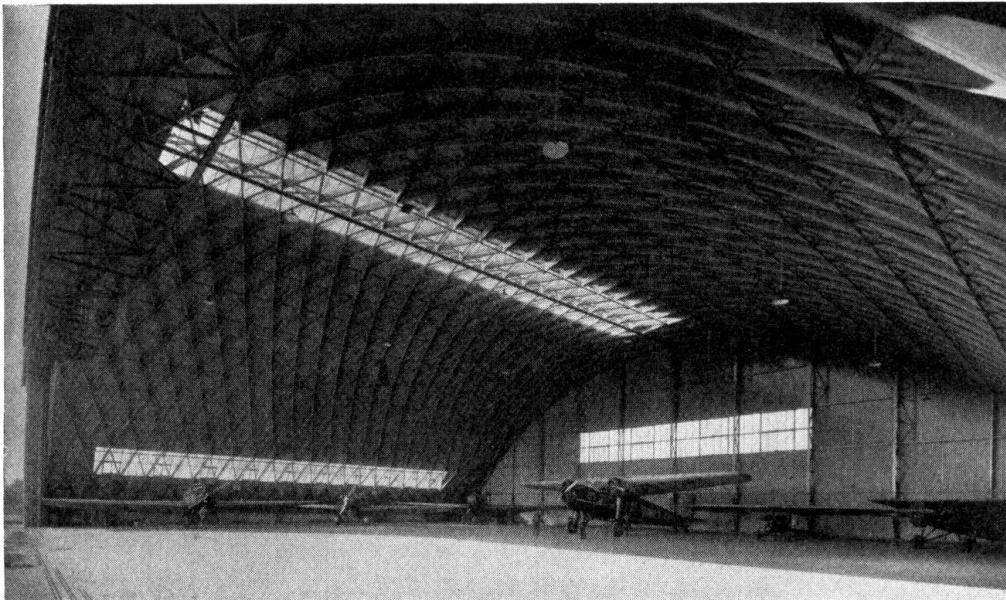

Fig. 11.

A special place among roofs is occupied by the type wherein the construction is of the coffered type. This offers not only a satisfactory solution to various technical problems but marked advantages from an architectural and aesthetic

point of view. There are some notable examples of these in Italy, especially over aircraft hangars and garages (Fig. 11).

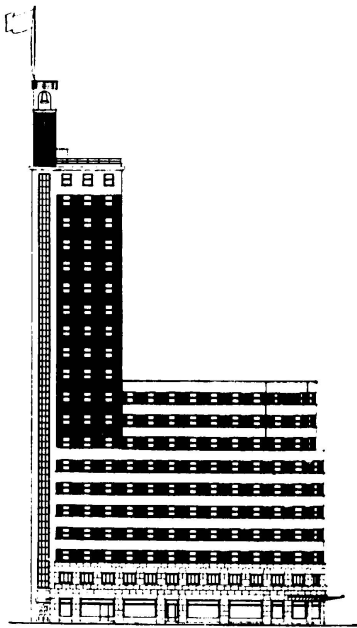

Fig. 12a.

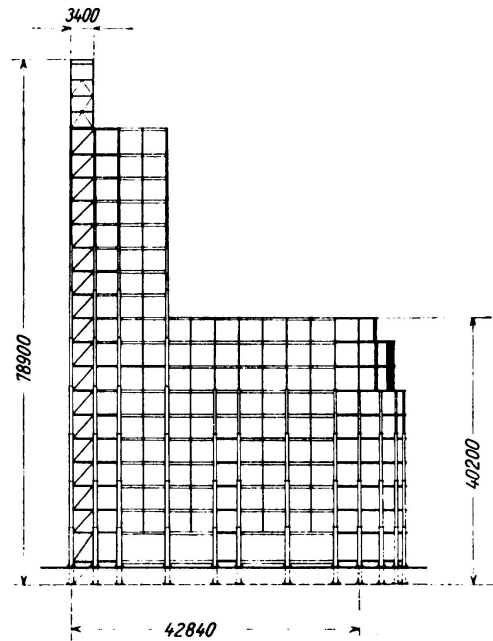

Fig. 12b.

4) In modern building practice the advantages of steel framing have become well recognised, but in Italy, on account of the high cost, steel framing is somewhat rare while concrete framing is common practice.

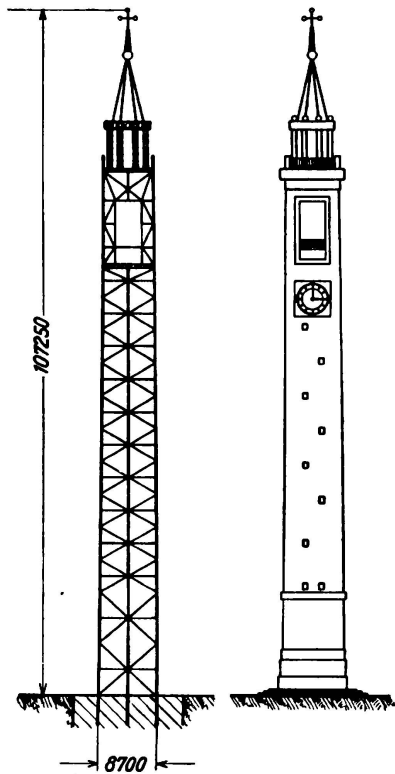

Fig. 13

An example of the latter, worth mentioning in view of its importance, is the new skyscraper at Turin (Figs. 12a and 12b) which is a large steel structure, entirely welded, reaching to a height of 80 m above ground level. Another is the bell tower at Sesto Calende (Fig. 13), some 100 m high and again of welded construction.

But rather than enlarge further upon these illustrations of rather special cases, it may be worth drawing attention to a field of work in Italy in which steel framed structures are assured of a promising future, namely that of earthquakeproof construction. Steelwork, in fact, possesses the best possible qualities for resisting seismic action — maximum lightness and maximum specific strength combined with a high degree of elastic deformability. It offers no less important advantages from a practical standpoint in that it can be manufactured in a few standardised types on an industrial scale by specialised works, and can be rapidly erected on the site by a few welders, thus reducing the call made upon local facilities which are often limited.

5) Arising from the extraordinary development of electrical installations in Italy one of the largest fields of application for steelwork is found in the construction of pylons for the transmission of energy. Allied to these, there may be mentioned, on account of the importance of the structural problems arising, the supporting towers for cable ways the number of which is continually increasing, and also aerials for wireless telegraphy and telephony.

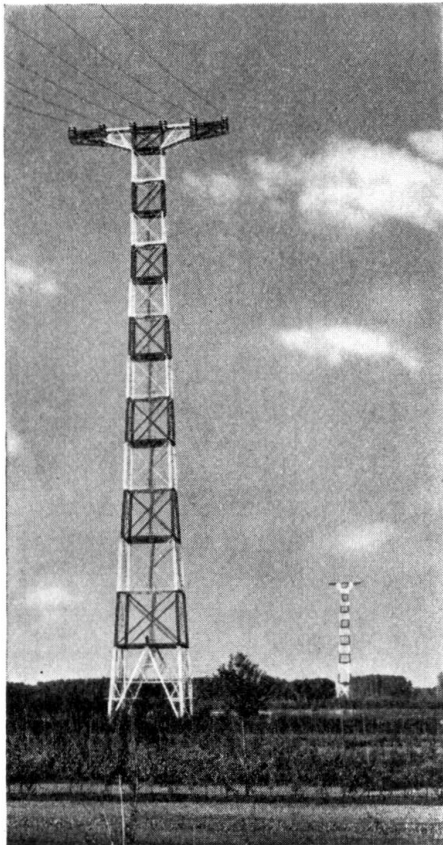

Fig. 14.

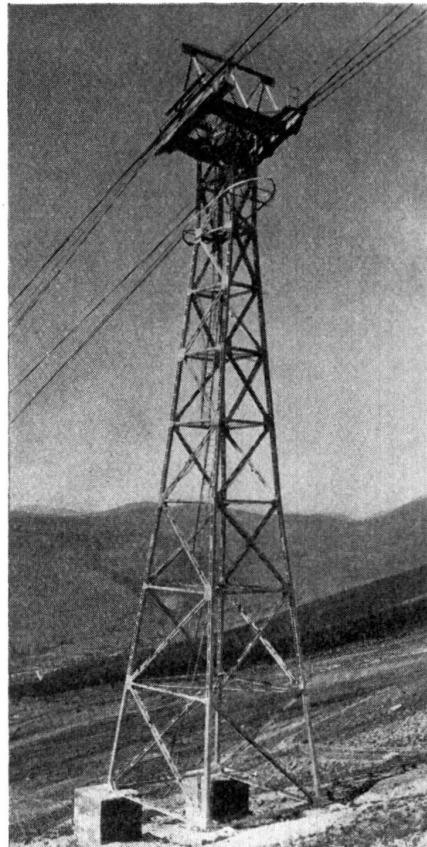

Fig. 15.

It would be of great interest to review different types of these structures as an outline of the process of evolution they have undergone in Italy, but having regard to the limited time available a few only of the most notable examples will be mentioned. Fig. 14 represents two high towers approximately 120 m above ground level for a crossing over the river Po with 1050 m span. Fig. 15 shows one of the modern pylons of welded construction to carry cable-ways namely those of the Gran Sasso d'Italia and Cervino (Matterhorn), wherein the spans are almost 1 km in length. Figs. 16a and 16b show the broadcasting station of Rome, San Palomba, which is one of the largest constructions of the kind. It reaches to the remarkable height of 267 m; the total weight of the aerial is 180 tonnes and the load on the insulator at the base is 290 tonnes.

6) A branch of engineering in which Italian industry has taken an important part is that of cranes for shipyards, factories and harbours. These are made of every kind and size, with frequent recourse to electric welding.

Here again it would be worth while to trace out the evolution of the different

types, but lack of time necessitates that reference should be confined to the crane represented in Figs. 17a and 17b, which is distinguished by its elegance

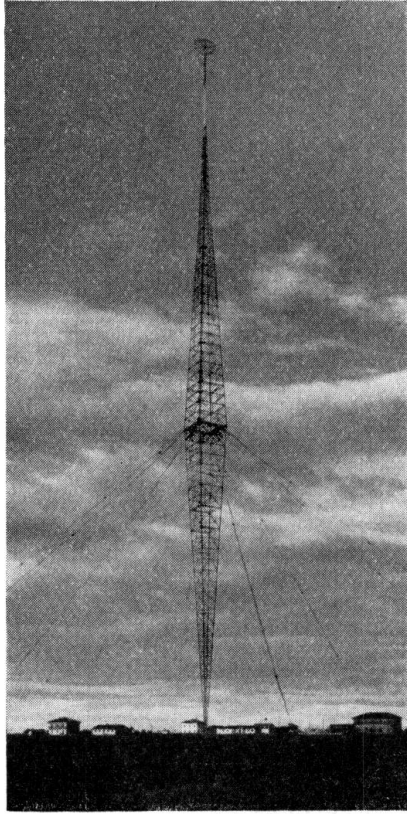

Fig. 16a.

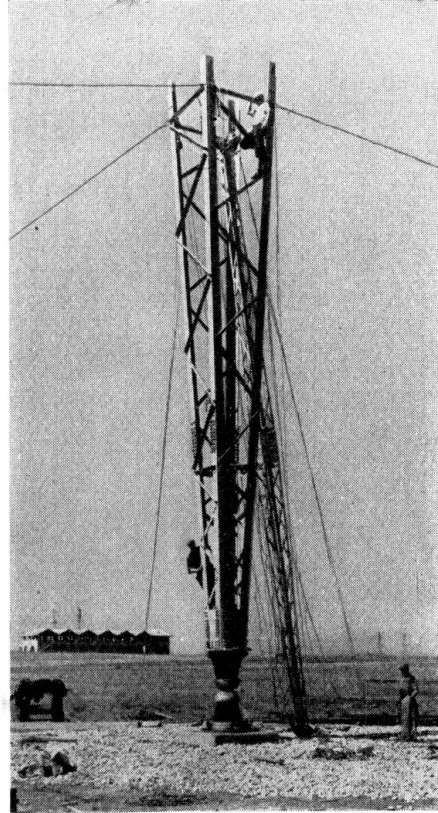

Fig. 16b.

of line and by the method of construction, entirely by welding. The vertical arm consists of two co-axial tubes; the inner tube is entirely welded and the

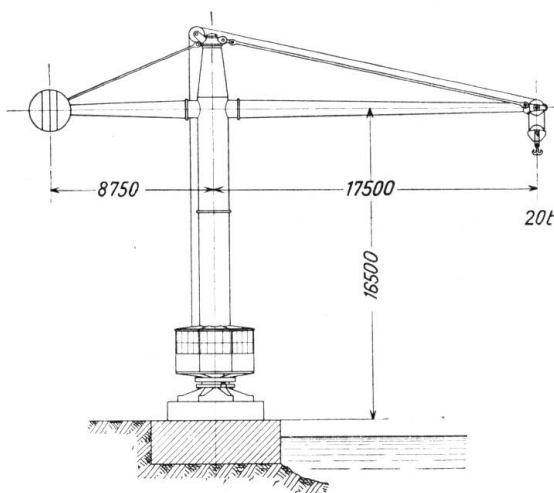

Fig. 17a.

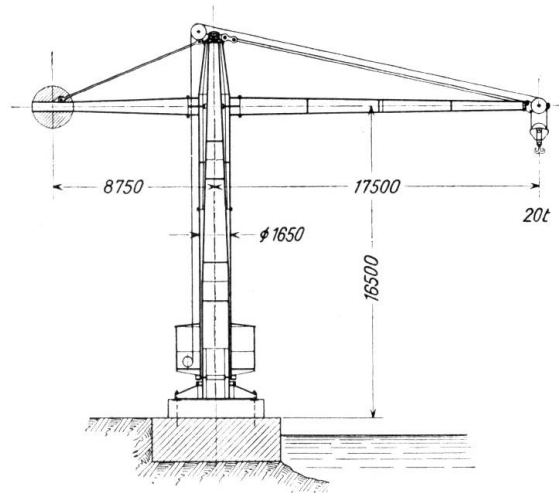

Fig. 17b.

outer one, for reasons of erection, is made in two parts connected by bolted flanges. The same form of connection is used between the two horizontal arms and the upper portion of the vertical member.

7) Finally reference may be made to some special structures made in weldless tubes of semi-hard steel, a form of work which has assumed a wide development

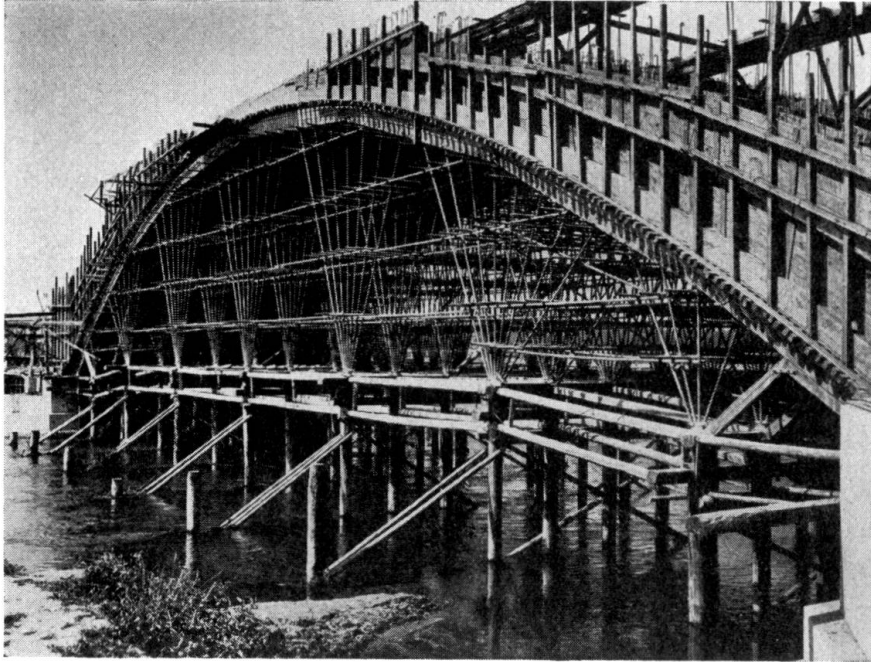

Fig. 18.

in Italy. Fig. 18 shows the centring for a concrete bridge over the river Ticino near Pavia. Fig. 19 shows the extensive falsework of the new bridge now in course of construction over the Tiber giving access to the Mussolini Stadium;

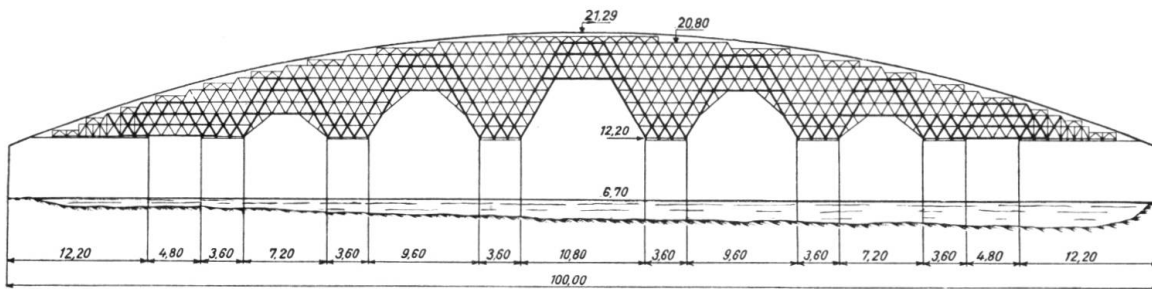

Fig. 19.

this will be a reinforced concrete bridge with a central arch of 100 m span. This centring involves the use of 64 000 m of tubing with 54 000 junction pieces.