

Zeitschrift: IABSE congress report = Rapport du congrès AIPC = IVBH
Kongressbericht

Band: 4 (1952)

Artikel: Studies of composite beams

Autor: Wästlund, Georg / Östlund, Lars

DOI: <https://doi.org/10.5169/seals-5050>

Nutzungsbedingungen

Die ETH-Bibliothek ist die Anbieterin der digitalisierten Zeitschriften. Sie besitzt keine Urheberrechte an den Zeitschriften und ist nicht verantwortlich für deren Inhalte. Die Rechte liegen in der Regel bei den Herausgebern beziehungsweise den externen Rechteinhabern. [Siehe Rechtliche Hinweise.](#)

Conditions d'utilisation

L'ETH Library est le fournisseur des revues numérisées. Elle ne détient aucun droit d'auteur sur les revues et n'est pas responsable de leur contenu. En règle générale, les droits sont détenus par les éditeurs ou les détenteurs de droits externes. [Voir Informations légales.](#)

Terms of use

The ETH Library is the provider of the digitised journals. It does not own any copyrights to the journals and is not responsible for their content. The rights usually lie with the publishers or the external rights holders. [See Legal notice.](#)

Download PDF: 15.10.2024

ETH-Bibliothek Zürich, E-Periodica, <https://www.e-periodica.ch>

BII 1

Studies of composite beams

Essai sur poutres composées

Versuche an Verbundträgern

GEORG WÄSTLUND

and

LARS ÖSTLUND, C.E.

Professor of Structural Engineering and Bridge
Building, Royal Institute of Technology,
Stockholm

Assistant at the Division of Structural Engineering
and Bridge Building, Royal Institute of Technology,
Stockholm

INTRODUCTION

In recent times designers have begun to utilise more and more the unity of action of a steel beam and a concrete slab resting on it. In such a structure shear forces occur between the steel and the concrete. In many cases the steel beam and the concrete slab act jointly even without any special shear connectors, but in order to ensure unity of action it is necessary to provide the beam with some special shear connection between steel and concrete. Details of several investigations on such shear connectors have been published. In the paper the authors first describe some tests made mainly to compare *different types of connectors*. Further tests made on composite *beams* of various types submitted either to positive or to negative moments are also described. All these tests were carried out at the Division of Structural Engineering and Bridge Building, Royal Institute of Technology, Stockholm.

TESTS ON VARIOUS TYPES OF SHEAR CONNECTORS

Different shear connectors were tested in the "push-out" specimens shown in fig. 1. An I-beam had a connector welded to each flange, and both connectors were embedded in 100 mm. thick concrete slabs. The slabs were cast in direct contact with the flanges of the beam, and were designed so that the whole section should be compressed during testing. The slip between the steel and the concrete was measured with four dial gauges.

To begin with, seven various types of shear connectors were tested. Their shapes and dimensions are given in fig. 2 and the following is their description. Two specimens of each type were tested.

Type I: No special shear connectors.

Type II: Connectors made of pieces of a channel-beam welded to the flanges of the I-beam.

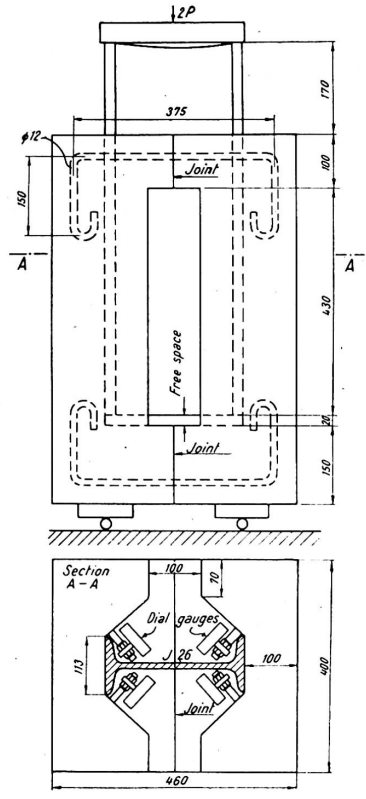

Fig. 1. Test specimen for testing shear connectors

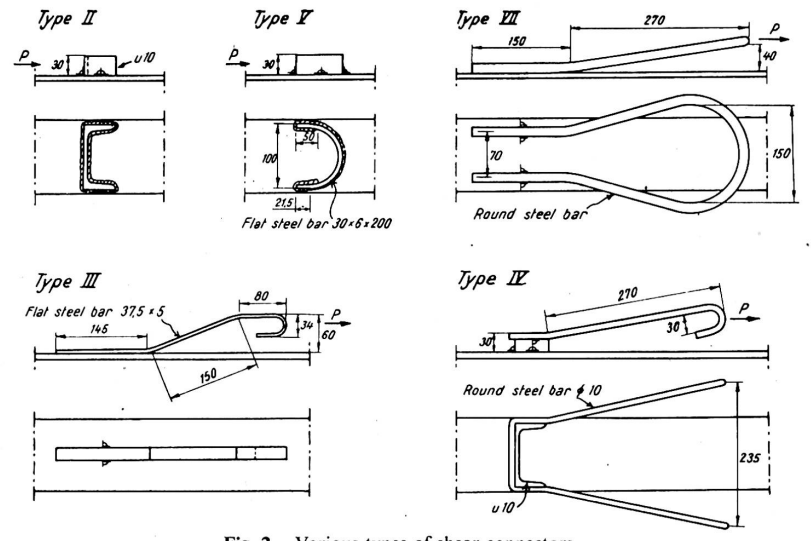

Fig. 2. Various types of shear connectors

Type III: Connectors made of flat steel bars hook-shaped as shown in fig. 2 and welded to the flanges.

Type IV: Connectors made of the same channel as type II and provided with two round steel bar hooks, \varnothing 10 mm., welded to the channels.

Type V: Connectors consisting of a rectangular steel plate semicircularly bent and welded to the flanges.

Type VI: Connectors of type III, but each slab horizontally reinforced with five \varnothing 10 mm. round bars at the outer side, and five \varnothing 6 mm. round bars at the inner side at right angles to the hooks.

Type VII: Connectors made of round steel bars, \varnothing 16 mm., bow-shaped as shown in fig. 2 and welded to the flanges of the I-beam.

During the testing the load was applied and removed as follows: $2P=0-5-0-5-10-0-5-10-15-0-5-10-15-20-0-20-0-20-0-20-25-30-0-30-35-40-45$. . . tons. The interval between two consecutive loads was about five minutes.

The results of these tests are shown in Table I, which gives the ultimate load, the slip between the steel and the concrete at the load $P=10$ tons, and the load P corresponding to a slip of 0.1 mm. Further, the weight of one connector is indicated in the table. To obtain a fair comparison between the various types, the compressive strength of the concrete (20-cm. cubes) is also given.

TABLE I

Type	Compr. strength, kg./cm. ²		Ultimate load P , tons		Slip at $P=10$ tons, 1/100 mm.		Load P at the slip 0.1 mm., tons		Weight of one connector, kg.
	each test	average	each test	average	each test	average	each test	average	
I	361	355	0.6	1.0	—	—	0.1	0.15	—
	350		1.5		—		0.2		
II	316	325	15.0	15.0	45	46	3.4	4.1	0.32
	334		15.0		47		4.8		
III	315	315	11.5	11.7	144	184	3.2	3.0	0.75
	316		12.0		224		2.8		
IV	337	328	20.6	20.0	16	16	8.2	8.1	0.79
	319		19.5		16		8.0		
V	267	265	14.8	12.9	52	90	4.0	3.6	0.28
	264		11.0		128		3.3		
VI	274	268	13.2	13.2	196	254	1.6	2.2	0.75
	263		13.2		312		2.9		
VII	252	259	20.0	20.6	12	19	10.0	9.0	1.53
	267		21.3		25		8.0		

From this table it will be seen that the types IV and VII are definitely better than

the other types, especially as regards the magnitude of the slip. When comparing these two types it is to be noted that the compressive strength of the concrete was lower in the specimens with connectors of type VII, and this type ought therefore to be better if the quality of the concrete were equal. The consumption of steel for the connectors of type IV is smaller than that for type VII, but the manufacture of type IV is more intricate. On the whole, type VII was considered the best, and was used in further tests.

A number of further similar tests were made (Table II); only the thickness of the round bars was varied. For specimen 8 the thickness was 12 mm.; for specimen 9, 16 mm.; and for specimen 10, 20 mm. In another series (specimens 21, 9 and 22) all dimensions except the length of the welds were varied on the same scale so that all connectors were uniform. The dimensions of the connectors are given in fig. 3. The steel used for these connectors was the Swedish grade St. 52, and had a yield-point stress of 3,500 kg./cm.² and an ultimate strength of 5,400 kg./cm.²

TABLE II

Specimen No.	Thick-ness of the round bars, mm.	Diameter of the bow, mm.	Compression strength kg./cm. ²		Ultimate load <i>P</i> , tons		Slip at <i>P</i> =10 tons, 1/100 mm.		Load <i>P</i> at the slip 0.1 mm., tons		Weight of one connector kg.
				aver.		aver.		aver.		aver.	
8A 8B 8C 8D	12	150	352 327 298 298	319	20 19 19 18	19	23 16 20 17	19	9.2 9.5 7.5 9.2	8.8	0.86
9A 9B 9C 9D	16	150	336 301 277 277	298	28 25 23 25	25	10 15 25 17	17	10.0 9.0 8.5 9.2	9.2	1.53
10A 10B 10C 10D	20	150	325 316 343 343	332	25 25 34 34	30	9 15 7 8	10	10.5 9.5 12.0 11.5	10.9	2.39
21A 21B	12	112	310 310	310	19 18	19	25 26	26	8.8 8.8	8.8	0.72
22A 22B	20	188	327 327	327	32 34	33	8 6	7	12.2 13.2	12.7	2.80

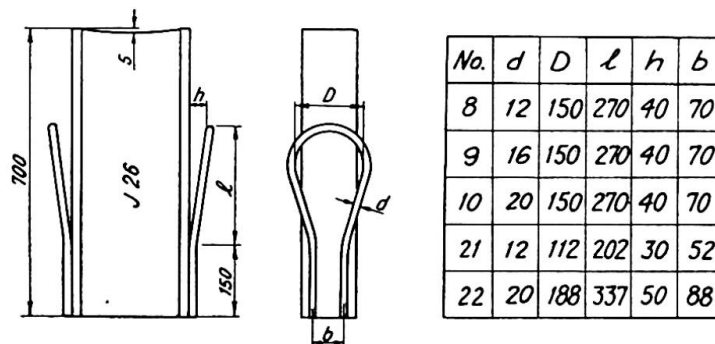

Fig. 3. The dimensions of the tested connectors of type VII

When the ultimate load was reached the concrete slabs were somewhat cracked. No fractures occurred in the connectors. It is possible that yielding occurred, but this could not be observed. Failure was therefore probably due to crushing and cracking of the concrete. It may be noted that the tensile stresses which would exist in the connector bars if they were assumed to take the whole ultimate load were in most cases greater than the ultimate strength of the steel. This indicates that there must have been a certain amount of bond between the steel and the concrete.

The variations in values in Table II are not greater than can be expected, if the specimens 10A and 10B, which have considerably smaller ultimate loads than the specimens 10C and 10D, are excepted. By comparing these values with the other values it is found that the values given for 10C and 10D seem to be the more correct and it is possible that some fault has occurred in specimens 10A and 10B. The results indicate that the ultimate load increases and the slip decreases as the round bars become thicker. The diameter and the other dimensions of the bow seem to have less influence on the ultimate load and the slip.

In practice, especially when the live load is great in comparison with the dead load, the shear connectors used in composite beams can be submitted to forces in the "wrong" direction, i.e. in the direction opposite to that in which the previous tests were made. Therefore, some tests have also been made with connectors of type VII turned in the "wrong" direction. The specimens 15, 16 and 17 were the same as 8, 9 and 10 respectively but the connectors were turned. The two slabs in this series were joined by means of round steel bars so that they could not separate from the flanges of the steel beam. Another type of specimen, 23, was exactly the same as the specimen 16 but the slabs were quite free, i.e. not joined. The tests were carried out in the same way as above, and the results are given in Table III.

TABLE III

Specimen No.	Thickness of the round bars, mm.	Diameter of the bows, mm.	Compression strength, kg./cm. ²		Ultimate load <i>P</i> , tons		Slip at <i>P</i> =10 tons, 1/100 mm.		Load <i>P</i> at the slip 0.1 mm., tons	
				aver.		aver.		aver.		aver.
15A 15B	12	150	270 254	262	15 15	15	26 39	32	7.5 6.3	6.9
16A 16B	16	150	272 321	296	19 21	20	17 14	16	9.0 9.7	9.3
17A 17B	20	150	379 362	370	22 24	23	6 6	6	12.5 13.0	12.7
23A 23B	16	150	346 346	346	11 11	11	70 47	58	5.2 5.8	5.5

When the separation of the slabs from the flanges of the steel beam was prevented, the results were fairly good, in some cases even better than those obtained with the shear connectors in the "right" direction. When the slabs were quite free, they were pushed out of the steel beam by the connectors even at a comparatively small load. However, the practical case comes somewhere between these two limit cases, and, further, smaller forces will generally act in the "wrong" direction on the shear connectors if they are appropriately designed. Therefore, the results may be regarded as satisfactory.

Considering all the test results given in the above tables, the large slip between the steel and the concrete at the ultimate load indicates that this load should not wholly determine the allowable load. If a slab shall act jointly with a steel beam the joint must be rigid, i.e. the slip must be small. From various points of view it was considered that a slip of about 0.1 mm. was allowable, and an allowable load of about 9 tons is obtained for one connector, ϕ 16 mm., a slightly smaller load for ϕ 12 mm., and a somewhat greater load for ϕ 20 mm. Connectors in the "wrong" direction should be allowed to carry about half the allowable load for connectors in the "right" direction. These values also provide satisfactory safety against rupture.

TESTS ON COMPOSITE BEAMS SUBMITTED TO POSITIVE MOMENT (COMPRESSION IN CONCRETE SLAB)

Six beams were tested, all having the shape and dimensions shown in fig. 4. The shear connection, however, was different, as may be seen from the following description.

Beams 11A and 11B: Shear connectors of type VII, cf. fig. 2, with round bars, ϕ 16 mm., placed as indicated in fig. 4.

Beams 13A and 13B: No special shear connectors between steel and concrete. A smooth plate, 6×130 mm., was welded to the upper flange of the steel beam so that the beams should be directly comparable with the beams 14 and 19.

Beam 14A: Shear connection between steel and concrete ensured by a grooved steel plate, 6×130 mm. (floor plate), welded to the upper flange of the steel beam (fig. 5). Except for the grooves, there was no special connection.

Beam 19A: Same as beam 14A, but small bows made of round bars, ϕ 8 mm., were welded to the grooved steel plate to prevent separation of the concrete slab from the steel beam (fig. 5).

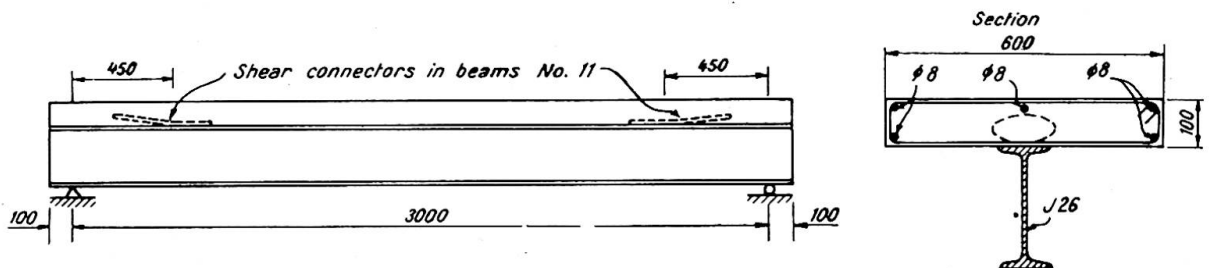

Fig. 4. Test beams No. 11

Some beams were loaded at the $1/3$ points of span (beams A) and some at the centre (beams B). The deflections of the beams were observed on dial gauges placed at the $1/3$ points on beam 11 and at the centre on the other beams. The slip between steel and concrete was observed on twelve dial gauges, six on each side of the beams. Finally, the distribution of the strain in the middle section of the steel beam was observed by means of electric strain-gauges. When this distribution is known, it is easy to calculate the resulting normal force acting on the steel section in the middle of the beam. In view of the conditions of equilibrium for half the steel beam, this normal force must be equal to the total shear force between the steel beam and the concrete slab. In other words, this shear force was observed indirectly.

The results of the tests on the beams A are shown in figs. 6 to 9. The tests on the beams B gave fundamentally similar results, but they are omitted here in order to save

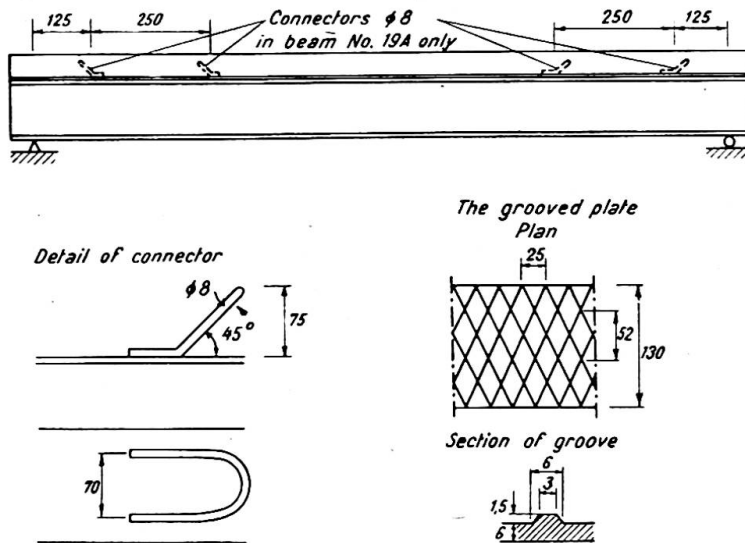

Fig. 5. Test beams No. 14 and No. 19

space. For comparison, the deflections and the shear forces have been calculated theoretically on the assumption of an infinitely rigid joint between the steel and the concrete, using the value $n = \frac{E_{steel}}{E_{concrete}} = 7$, and $n = 15$. The results of these calculations are also shown in figs. 6 to 8. The compressive strength of the concrete of the slab is given in Table IV.

TABLE IV

Beam No.	Compressive strength of concrete, kg./cm. ²
11A	342
13A	311
14A	260
19A	308

Fig. 6 shows the deflection δ in the two $1/3$ points of the beam 11A as a function of the load P . At the loads of 18 tons and 24 tons, the strength of bond between the steel and the concrete was exceeded first on the one side of the beam and then on the other. After that, the shear connectors had to withstand the shear force which caused slip between the steel and the concrete without any increase in load.

Fig. 7 shows the deflection δ at the centre of the beams 13A, 14A and 19A as a function of the load P .

In fig. 8 the total shear force T between the steel beam and the concrete slab is plotted as a function of the load P for all beams A. Fig. 9 shows the relation between the total shear force T and the slip at that end of the beam where large slips occurred first. These two diagrams show an important difference between the beams provided with special connectors keeping the steel beam and the concrete slab together (beams 11A and 19A) and the beams without such connectors (beams 13A and 14A). The strength of bond between the steel and the concrete was exceeded at loads of 6 tons and 18 tons in the beams 13A and 14A respectively (fig. 8). When the load was

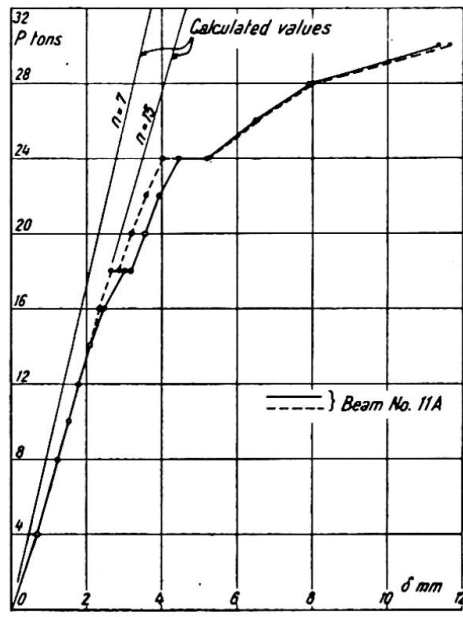

Fig. 6. The deflection δ in the two 1/3 points of beam No. 11A as a function of the load P

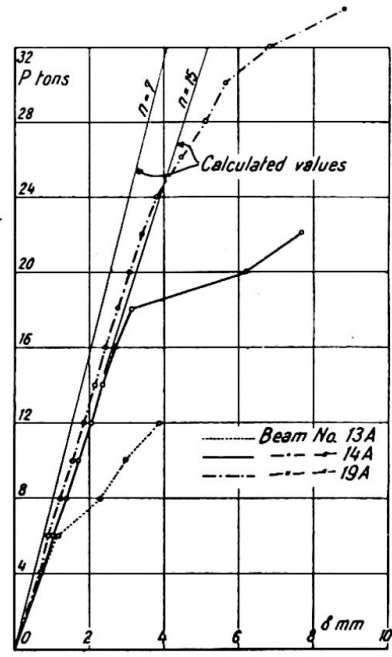

Fig. 7. The deflection δ at the centre of beams No. 13A, No. 14A and No. 19A as a function of the load P

further increased the slip increased too, but the shear force decreased and did not reach its maximum value again. The bond between the steel and the concrete was destroyed for ever. When the bond strength was exceeded in beam 14A, the slab was lifted from the grooves. In the beams 11A and 19A the bond strength was exceeded at loads of 16 tons and 24 tons respectively. But when the load was further increased, the shear force also increased even if the load was removed and applied again. These tests show the importance of a reliable connection between the steel

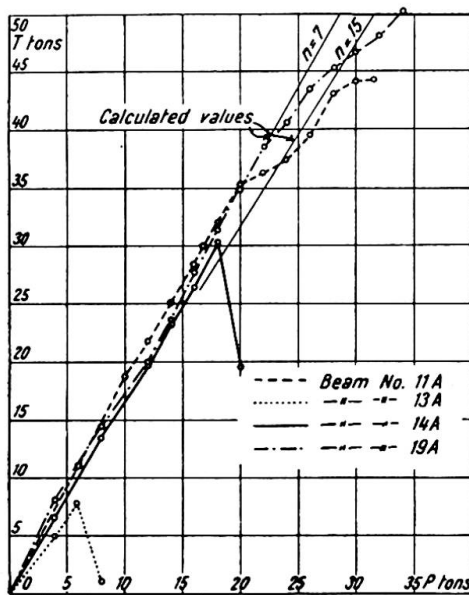

Fig. 8. The total shear force T as a function of the load P

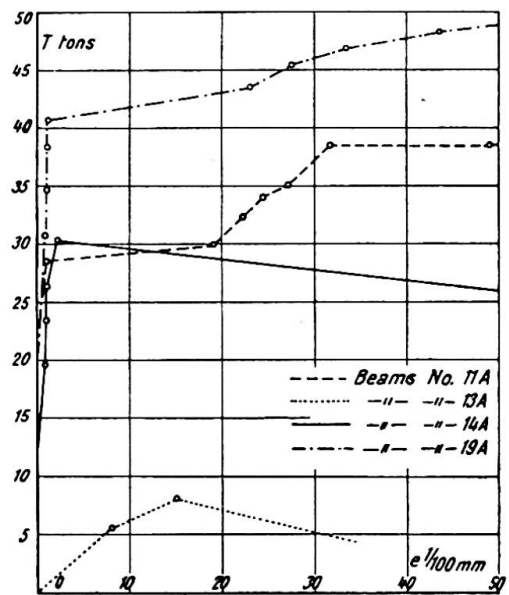

Fig. 9. Relation between the total shear force T and the slip e between steel and concrete

beam and the concrete slab. A brittle rupture between steel and concrete is dangerous, as stresses due to shrinkage and changes in temperature cannot be calculated very accurately. Furthermore, it is to be noted that the ultimate shear force in the test beam 11A, with *one* shear connector of type VII on each half of the beam, was as great as 44 tons. When the connectors were tested separately in the specimens shown in fig. 1, an ultimate load of about 25 tons was observed. The difference is considerable, and is possibly due to friction forces between steel and concrete occurring when the bond strength is exceeded. Perhaps this difference is partly due to the shrinkage of the concrete which causes initial shear forces in a direction opposite to that obtained during the tests. Anyhow, if the shear connectors are designed as proposed in the first part of the paper, the safety ought to be quite satisfactory.

TESTS ON COMPOSITE BEAMS SUBMITTED TO NEGATIVE MOMENT (TENSION IN CONCRETE SLAB)

Five beams were tested. They all had the same dimensions as the beams tested under the action of positive moments, and the load was applied at their 1/3 points. The special characteristics of the various types of beams are given below.

Beams 12 (two beams): The concrete slab was reinforced with nine round bars, \varnothing 16 mm., of the Swedish steel grade St. 52 (yield-point 3,500 kg./cm.², tensile strength 5,400 kg./cm.²). Shear connectors of type VII made of round bars, \varnothing 16 mm., were used; one on each half of the beam (fig. 10).

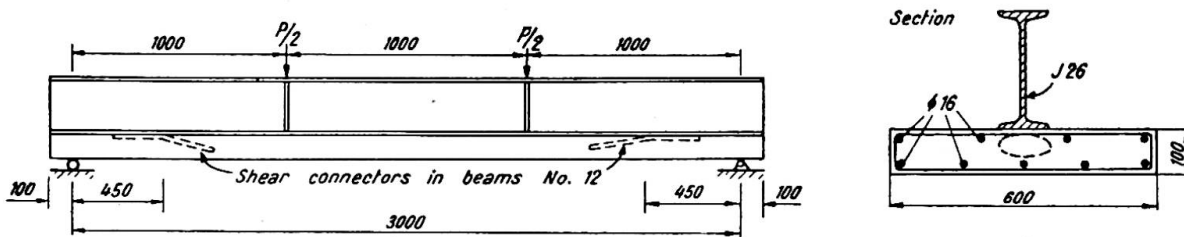

Fig. 10. Test beams No. 12

Beams 18 (two beams): Just as in the beams 12, the slab was reinforced with nine round bars, \varnothing 16 mm., St. 52. No special shear connectors were used, but each reinforcement bar was bent down and welded to the upper flange of the steel beam (fig. 11). This design was suggested by Dr. A. Aas-Jakobsen, Oslo.

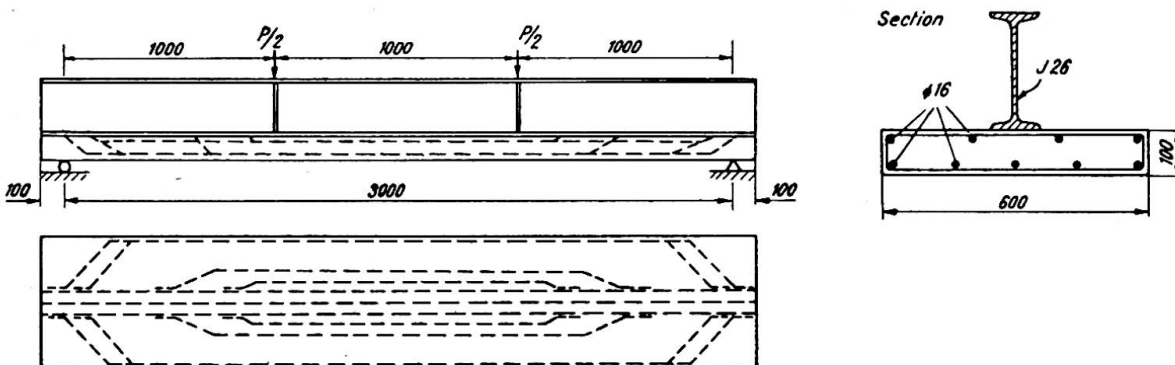

Fig. 11. Test beams No. 18

Beam 20 (one beam): In this beam the concrete slab was prestressed so that it was able to withstand a certain tension without cracking. Shear connectors of type VII made of round bars, $\varnothing 20$ mm., were used; three on each half of the beam. This test is described in another paper*, and the description will not be repeated here in order to save space. It is only mentioned for the sake of completeness.

The deflections, the slip between the steel beam and the concrete, and the strains in the middle section of the beams were observed in exactly the same way as in the tests on the beams submitted to positive moments. The cracks in the concrete slabs were also observed.

The results of these tests are shown in figs. 12 to 14, but only for one beam of each type, as the results were approximately equal for the beams of the same type. For comparison, theoretical values calculated for $n=7$, $n=15$ and $n=\infty$ are also shown in figs. 12 and 13. The compressive strength of the concrete of the slab was 358 kg./cm.^2 for beam 12 and 327 kg./cm.^2 for beam 18.

Fig. 12 shows the deflection δ at the $1/3$ points of the beams 12 and 18 (δ is almost exactly equal at both points) as a function of the load P .

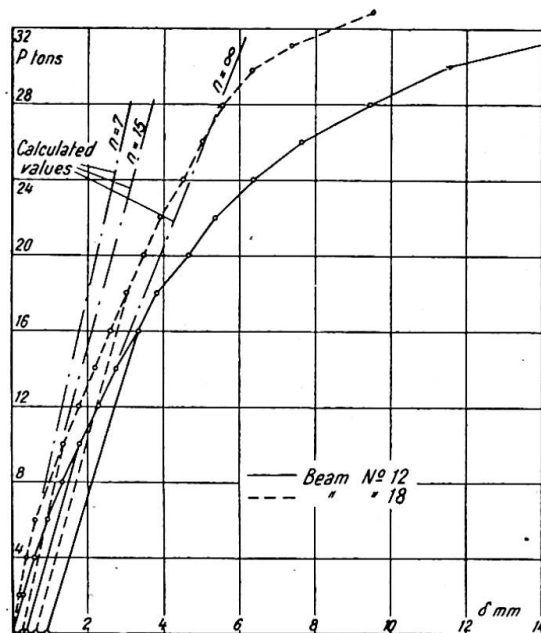

Fig. 12. The deflection δ of beams No. 12 and No. 18 as a function of the load P

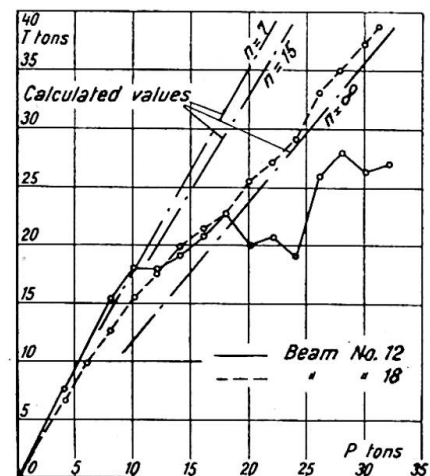

Fig. 13. The total shear force T as a function of the load P

In fig. 13 the total shear force T is given as a function of the load P . At small loads, when the concrete is not yet cracked, the curves follow the curves calculated for $n=7$ or 15 . But when the load is increased, the concrete cracks more and more (the first cracks occurred in both beams 12 and 18 when the load was 12 tons), and the curves approach the curves calculated for $n=\infty$. In beam 12 the bond between steel and concrete was impaired on one side of the beam at a load of 19.5 tons, and on the other side at a load of 23.8 tons. This was indicated by a considerable slip between the steel beam and the concrete slab. When the bond was impaired, the shear force T

* Wästlund, G., and Östlund, L.: "Tests on a Composite Beam with a Prestressed Slab," Congrès International du Béton Précontraint, Ghent, 1951.

decreased temporarily, and the loss of bond is therefore clearly marked in the curve. The ultimate total shear force in beam 12 was about 28 tons, i.e. about the same as the ultimate load of the shear connectors used in this beam, tested in the specimens described in the first part of the paper. In beam 18 there was no great slip between the steel beam and the concrete slab, and the shear force approximately follows the curve calculated for $n = \infty$ up to the ultimate load of the beam. The relation between the total shear force T and the slip between steel and concrete at one end of beam 12 is shown in fig. 14. In beam 18 the greatest slip observed was 0.05 mm.

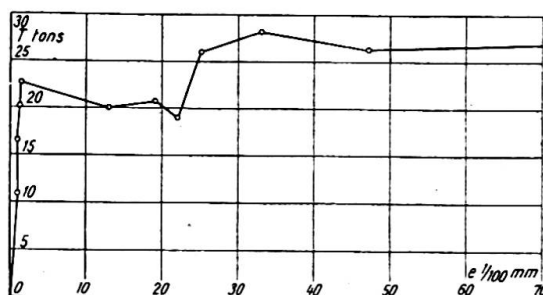

Fig. 14. Relation between the total shear force T and the slip e between steel and concrete (Beams No. 12)

It is evident from fig. 12 that if a composite beam is submitted to a negative moment the concrete cannot be assumed to act jointly with the steel beam, as it generally cracks at relatively small tensile stresses. However, if the connection between the steel beam and the concrete slab is sufficient, the *reinforcement* in the slab acts jointly with the steel beam (i.e. $n = \infty$). Two types of such connections have been tested, and the method used in beam 18 seems to be the best, as it results in a very rigid connection between the steel beam and the concrete. Of course, the number and the size of shear connectors in beam 12 could be increased, but even then there would be a noticeable slip between steel and concrete at high loads. This fact appeared from the test on beam 20, in which three connectors made of round bars $\varnothing 20$ mm. were used for each half of the beam. The cracks were relatively small in the tests on beams 12 and 18 (the width of the biggest crack was about 0.1 mm. at a load of 16 tons and about 0.2 mm. at a load of 30 tons), probably owing to the relatively high ratio of reinforcement. Finally, it may be pointed out that the ultimate loads of the shear connectors in beam 12 were considerably smaller than those obtained for the beams submitted to a positive moment.

In the test on the beam with the prestressed slab, it was found that this beam acted as expected in most respects, i.e. the concrete and the steel beam acted jointly until the concrete cracked. This occurred at a considerably higher load (26 tons) than in the other beams (12 tons).

ACKNOWLEDGMENTS

Most of the tests were carried out as graduation theses by the following students: E. Enhamre, G. Rosenborg, R. Werner, A. Norling, O. Nygren, L. Wettermark, R. Albåge, R. Loothagen, C. Rehn, G. Holmquist, L. Hellström, S. Lundblad and L. Laurell. The authors wish to thank them for their valuable contributions to the investigation.

Summary

The first part of this paper describes tests on different types of shear connectors tested in "push-out" specimens. The results showed that one type of connector (type VII) consisting of a bow-shaped round steel bar welded to the flange of the steel beam was the best of the types tested.

The second part deals with composite beams subjected to positive moments. Six beams were tested, viz. two without any shear connection between the steel beam and concrete slab (13A and 13B), two with shear connectors of type VII (11A and 11B), and two with a shear connection consisting of grooves in the upper flange of the steel beam. One of the latter two beams had no other connection (14A), whereas the second beam was furthermore provided with small connectors keeping the steel beam and the concrete slab together (19A). The results of the tests indicated that the beams without connectors (13A, 13B and 14A) were not satisfactory. The other beams gave good results, especially beam 19A which had a very rigid joint between the steel and the concrete.

The third part deals with composite beams subjected to negative moments. Five beams were tested, viz. two with shear connectors of type VII, two with the reinforcement in the slab bent down and welded to the upper flange of the steel beam, and, finally, one with a prestressed concrete slab and shear connectors of type VII. The results of the tests indicate that the concrete in the beams with non-prestressed slab cannot be assumed to act jointly with the steel beam, as it generally cracks at comparatively small loads. However, if the connection between steel and concrete is satisfactory, the reinforcement in the slab acts jointly with the steel beam. The beam with the prestressed slab was satisfactory in most respects and, owing to prestressing, the concrete acted jointly with the steel beam up to high loads.

Résumé

Dans la première partie du rapport, l'auteur expose les résultats d'essais de cisaillement qui ont été effectués sur des poutres composées assemblées suivant différents modes de goujonage. Ces essais ont montré que le mode le plus avantageux est le goujonage réalisé avec un fer rond recourbé en boucle et soudé sur les ailes de la poutre (type VII).

La deuxième partie du rapport traite du comportement des poutres composées soumises à des contraintes dues à des moments positifs. Six poutres ont été essayées, à savoir: deux poutres ne comportant aucune protection contre le cisaillement entre poutre métallique et dalle de béton, deux poutres avec goujonage suivant type VII et deux poutres avec assemblage constitué par une ondulation de la bride supérieure de la poutre. L'un des deux derniers groupes de poutres ne comportait aucun autre élément d'assemblage entre poutre métallique et dalle de béton; l'autre groupe (19A) comportait un élément d'assemblage additionnel par petits goujons. Les essais ont mis en évidence le comportement insuffisant des poutres ne comportant aucun goujonage. Les autres poutres ont donné de bons résultats, tout particulièrement le type 19A, dans lequel un assemblage très rigide est réalisé entre l'acier et le béton.

La troisième partie du rapport porte sur les poutres composées soumises à des contraintes dues à des moments négatifs. Cinq poutres ont été essayées, dont deux avec assemblages suivant type VII, deux dans lesquelles les armatures de la dalle de béton sont recourbées vers le bas et soudées à l'aile supérieure de la poutre métallique et enfin une poutre comportant une dalle en béton précontraint et assemblages suivant type VII. Les essais ont montré que dans celles des poutres ci-dessus qui ne comportaient pas une dalle de béton précontraint, on ne pouvait tabler sur aucune coopéra-

tion entre le béton et les poutres métalliques, car il se manifestait une fissuration dans le béton, dès l'application de charges relativement faibles. La coopération entre l'armature de la dalle et la poutre métallique paraît toutefois assurée lorsque la liaison entre le béton et la poutre métallique est satisfaisante. La poutre métallique avec dalle en béton précontraint donne des résultats satisfaisants à presque tous les égards et grâce à la précontrainte, la coopération entre béton et poutre est parfaite, jusque sous des charges élevées.

Zusammenfassung

Im ersten Teil des Aufsatzes werden Scherversuche beschrieben, die mit verschiedenen Dübel-Typen durchgeführt wurden. Auf Grund dieser Versuche kann die durch ein schleifenförmig gebogenes, an den Flanschen des Stahlträgers angeschweisstes Rundeseisen gebildete Verdübelung (Typ VII) als die beste der untersuchten Ausführungen bezeichnet werden.

Der zweite Teil behandelt Verbundträger unter positiver Momentenbeanspruchung. Es wurden 6 Balken untersucht, nämlich zwei ohne jegliche Schubsicherung zwischen Stahlträger und Betonplatte, zwei mit Dübeln vom Typ VII und zwei mit einer durch Riffelung des oberen Trägerflansches gebildeten Verdübelung. Der eine der letztgenannten zwei Träger besass keine weiteren Verbindungen zwischen dem Stahlträger und der Betonplatte, während der andere (19A) zusätzlich mit kleinen Dübeln versehen war. Die Versuche zeigten die ungenügende Wirkung der Balken ohne Verdübelung. Bei den anderen Trägern wurden gute Ergebnisse erzielt, besonders beim Träger 19A, bei dem der Verbund zwischen Stahl und Beton sehr starr war.

Der dritte Teil des Berichtes behandelt Verbundträger unter negativer Momentenbeanspruchung. 5 Träger wurden untersucht, zwei davon mit Verbindungen vom Typ VII, zwei weitere, bei denen die Bewehrung der Platte nach unten abgebogen und an den oberen Flansch des Stahlträgers angeschweisst war und ein letzter Träger mit einer Platte aus vorgespanntem Beton und Verbindungen vom Typ VII. Die Versuchsergebnisse zeigen, dass bei denjenigen Trägern, welche nicht mit einer Platte aus vorgespanntem Beton versehen sind, kein Zusammenwirken zwischen Beton und Stahlträgern angenommen werden darf, da die Rissebildung im Beton bereits bei verhältnismässig kleinen Belastungen auftritt. Das Zusammenwirken der Plattenbewehrung mit dem Stahlträger erscheint jedoch als gesichert, wenn die Verbindung zwischen Stahl und Beton befriedigend ist. Der Träger mit der Platte aus vorgespanntem Beton ergab fast in jeder Beziehung zufriedenstellende Resultate und das Zusammenwirken des Betons mit dem Stahlträger war dank der Vorspannung bis zu hohen Belastungen einwandfrei.

Leere Seite
Blank page
Page vide