

The behaviour of a symmetrical pitched roof portal loaded to collapse

Autor(en): **Horne, M.R.**

Objektyp: **Article**

Zeitschrift: **IABSE congress report = Rapport du congrès AIPC = IVBH
Kongressbericht**

Band (Jahr): **5 (1956)**

PDF erstellt am: **13.09.2024**

Persistenter Link: <https://doi.org/10.5169/seals-6080>

Nutzungsbedingungen

Die ETH-Bibliothek ist Anbieterin der digitalisierten Zeitschriften. Sie besitzt keine Urheberrechte an den Inhalten der Zeitschriften. Die Rechte liegen in der Regel bei den Herausgebern.

Die auf der Plattform e-periodica veröffentlichten Dokumente stehen für nicht-kommerzielle Zwecke in Lehre und Forschung sowie für die private Nutzung frei zur Verfügung. Einzelne Dateien oder Ausdrücke aus diesem Angebot können zusammen mit diesen Nutzungsbedingungen und den korrekten Herkunftsbezeichnungen weitergegeben werden.

Das Veröffentlichen von Bildern in Print- und Online-Publikationen ist nur mit vorheriger Genehmigung der Rechteinhaber erlaubt. Die systematische Speicherung von Teilen des elektronischen Angebots auf anderen Servern bedarf ebenfalls des schriftlichen Einverständnisses der Rechteinhaber.

Haftungsausschluss

Alle Angaben erfolgen ohne Gewähr für Vollständigkeit oder Richtigkeit. Es wird keine Haftung übernommen für Schäden durch die Verwendung von Informationen aus diesem Online-Angebot oder durch das Fehlen von Informationen. Dies gilt auch für Inhalte Dritter, die über dieses Angebot zugänglich sind.

I a 3

The behaviour of a symmetrical pitched roof portal loaded to collapse

Discussion

Das Verhalten eines symmetrischen Portalrahmens mit geneigten Dachflächen bei einer Beanspruchung die um zum Bruch führt

Diskussion

Ensaio de rotura de um pórtico simétrico de duas águas

Discussão

Essai à la rupture d'un portique symétrique à deux pans

Discussion

M. R. HORNE

Sc. D., A. M. I. C. E.

Cambridge University

Cambridge

The authors give the calculated deflections of their portal frame when it is just on the point of collapse, obtained by the method described by Symonds and Neal [9]. In practice, it may be of greater interest to be able to calculate the deflections before this stage is reached, but after plastic deformation has occurred at certain sections. Unfortunately, such calculations are difficult, since it is not known *a priori* at which sections plastic hinges occur at a given load. Hence several analyses may have to be made before the correct solution is obtained. It is thus desirable to use a rapid method for setting down the equations for the general case, making no assumptions regarding the positions of the hinges. A convenient procedure based on an adaptation of the elastic traverse method of analysis [10] will be described, and illustrated by reference to the portal frame discussed by Baker and Eickhoff.

The principle of the traverse method for elastic members is shown in Fig. 1 (b). The prismatic member AB [Fig. 1 (a)] is subjected to transverse loads, together with terminal moments M_A and M_B . The actual deformation of the centre line may be replaced by two angular discontinuities at the third points, as shown in Fig. 1 (b). The values of the discontinuities are $-\frac{1}{2EI}(M_A - M_{FA})$ and $-\frac{1}{2EI}(M_B - M_{FB})$

where M_{FA} and M_{FB} are the fixed-end moments due to the transverse loads, l is the length of the member, and EI is its flexural rigidity.

Suppose that the bending moment at some point C in the member, distance a from A , reaches the full plastic value M_P [Fig. 1 (c)]. It will

TRAVERSE METHOD FOR ELASTIC AND ELASTIC-PLASTIC MEMBERS.

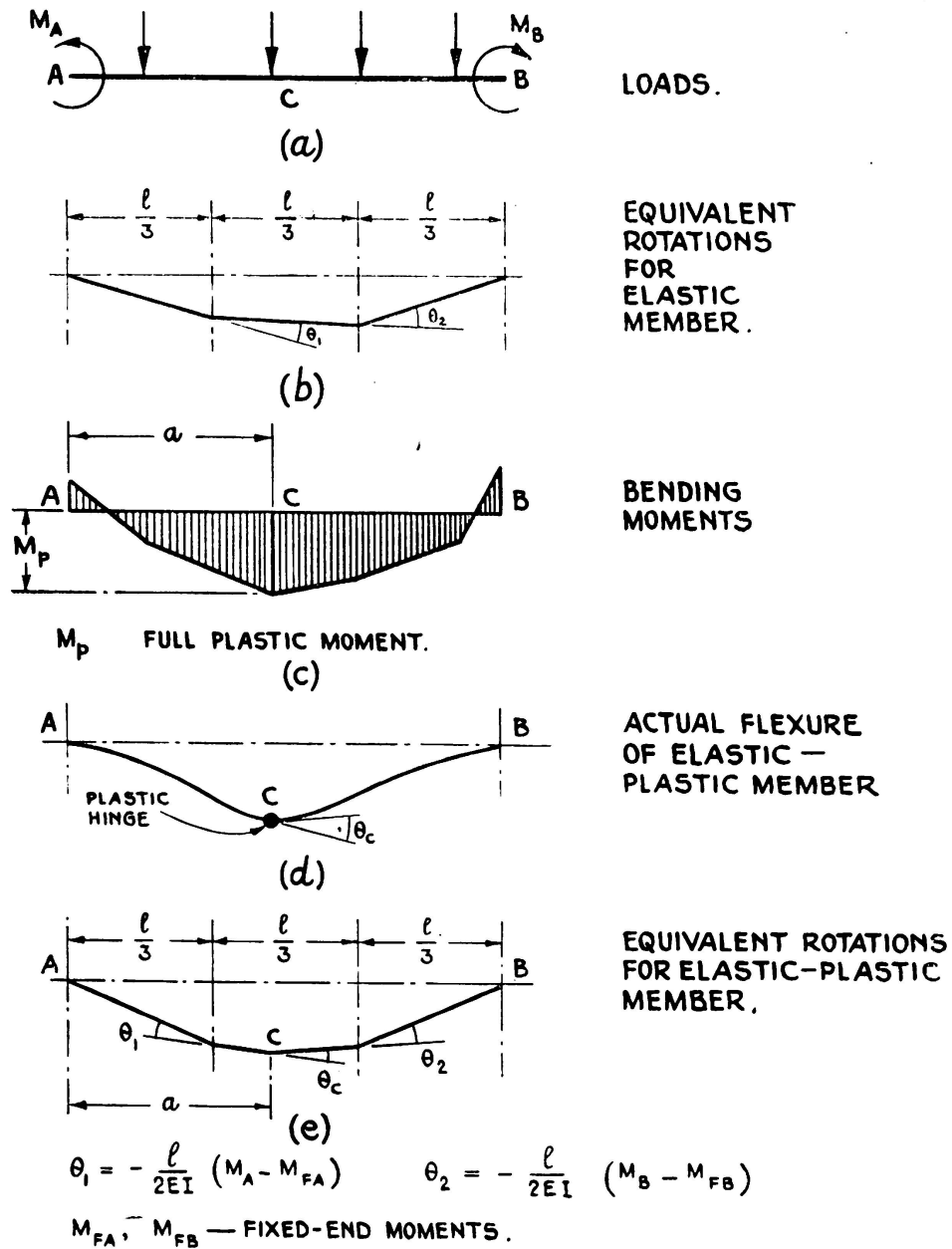

FIG. 1

be assumed that the shape factor of the member is unity, so that all plastic deformation is confined to the sections at which full plasticity occurs. The total deformation of the member then includes a plastic

hinge rotation θ_c [Fig. 1 (d)], and this must be added to the usual angular discontinuities corresponding to elastic flexure to obtain the total equivalent deformation [Fig. 1 (e)]. In general, it will be sufficiently accurate to add the plastic hinge rotation θ_c to the nearest third point of the member (including the ends), thus simplifying the calculations when the member forms part of a rigid frame.

The generalised rotations which are assumed when analysing the pitched roof frame described by Baker and Eickhoff are shown in Fig. 2. Since the loads W and H are applied at joints, no fixed-end moments

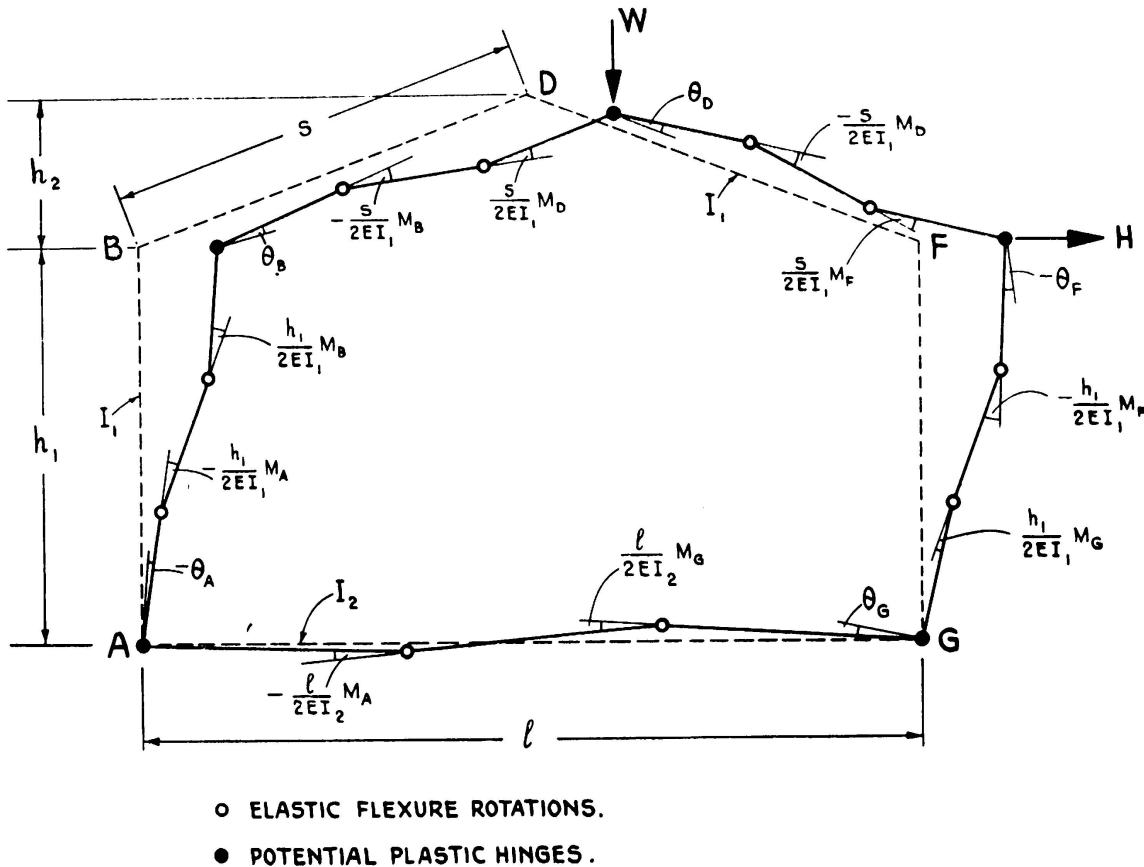

FIG. 2

occur in the expressions for the elastic flexure rotations. The bending moments at A, B etc. are denoted by M_A, M_B , etc., moments being accounted positive when they produce tension on the inside of the frame. Potential plastic hinge positions are at the five joints, and arbitrary rotations θ_A, θ_B , etc. are ascribed to these sections. These rotations are accounted positive when they produce deformation convex to the inside of the frame. The symbols $E I_1$ and $E I_2$ denote the flexural rigidities of the frame and base beam respectively, l is the span, h_1 the height to eaves, h_2 the height from eaves to apex, and s is the length of a rafter.

The requirements of frame continuity lead to three equations, as shown in Fig. 3. Taking $l = 192$ inches, $h_1 = 96$ inches, $h_2 = 37.2$ inches, $s = 102.9$ inches, $E I_1 = 5.73 \times 10^5$ tons inches and $E I_2 =$

$= 34.0 \times 10^5$ tons inches, and expressing the bending moments in tons inches, the equations become

$$0.645 M_A + M_B + 1.035 M_D + M_F + 0.645 M_G + 5.76 \times 10^5 (\theta_A + \theta_B + \theta_D + \theta_F + \theta_G) = 0 \quad (1)$$

$$0.649 M_A + M_B - M_F - 0.649 M_G + 6.96 \times 10^3 (\theta_A + \theta_B - \theta_F - \theta_G) = 0 \quad (2)$$

$$1.525 M_A + M_B + 0.278 M_D + M_F + 1.525 M_G + 4.64 \times 10^3 (3.58 \theta_A + \theta_B + \theta_F + 3.58 \theta_G) = 0 \quad (3)$$

In addition to these equations, there are two equations of equilibrium relating the bending moments to the applied loads. These may be obtained

FLEXURAL EQUATIONS (3)

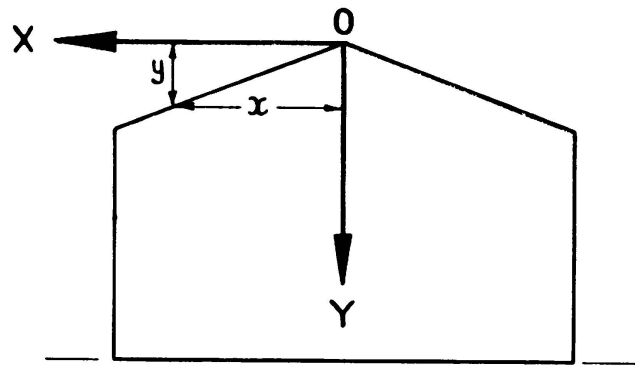

$$\sum \theta = 0 \quad (1)$$

$$\sum x\theta = 0 \quad (2)$$

$$\sum y\theta = 0 \quad (3)$$

FIG. 3

by considering the virtual work equations for two independent mechanisms, as shown in Fig. 4. When numerical values for dimensions are inserted, it is found that

$$-M_A + M_B - M_F + M_G = 96 H \quad (4)$$

$$-M_B + 2 M_D - 1.775 M_F + 0.775 M_G = 96 W + 74.4 H \quad (5)$$

The above five equations are sufficient to determine all the moments and rotations at any given values of W and H .

At each joint in the frame, there is either no plastic hinge and the members are elastic, that is

$$\theta = 0 \quad \text{and} \quad -M_p < M < M_p$$

or full plasticity occurs, in which case,

$$\text{if } \theta > 0, \text{ then } M = M_p \text{ and}$$

$$\text{if } \theta < 0, \text{ then } M = -M_p.$$

Hence, whatever the loads, there are five unknown numerical quantities. When performing an analysis, the assumption has to be made regarding

EQUILIBRIUM EQUATIONS (2)

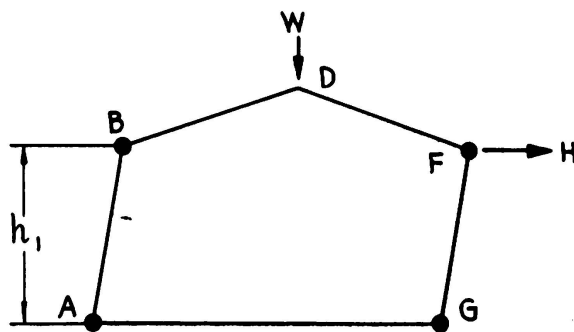

$$-M_A + M_B - M_F + M_G = Hh_1$$

(4)

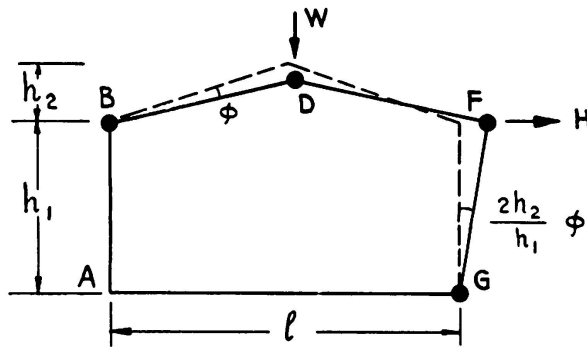

$$-M_B + 2M_D - \left(\frac{h_1 + 2h_2}{h_1}\right) M_F + \frac{2h_2}{h_1} M_G = \frac{Wl}{2} + 2Hh_2$$

(5)

FIG. 4

which joints have become fully plastic. The correct assumptions will lead to a solution in which all the above inequalities are satisfied. It is evident that a moment in excess of M_p denotes a hinge position where none has been assumed, while a hinge rotation of the wrong sign denotes that a hinge has been inserted where the frame is actually still elastic. The correct solution may thus be obtained by trial and error, or alternatively by tracing the formation of the hinges as the loads are increased.

The solutions of equations (1) to (5) for the pitched roof frame of Baker and Eickhoff are summarised in Table I for each load at which a new plastic hinge just forms. The theoretical and experimental load deflection relations are compared in Fig. 5, the loads at which the various sections first become plastic being indicated. The theoretical deflections are less than the actual values, due presumably to

- 1) the incomplete rigidity of the joints, and
- 2) the spreading of the plastic zones either side of the fully plastic sections.

The calculated deflections at the point of collapse are in agreement with the authors' values. It is interesting to note that, whereas the

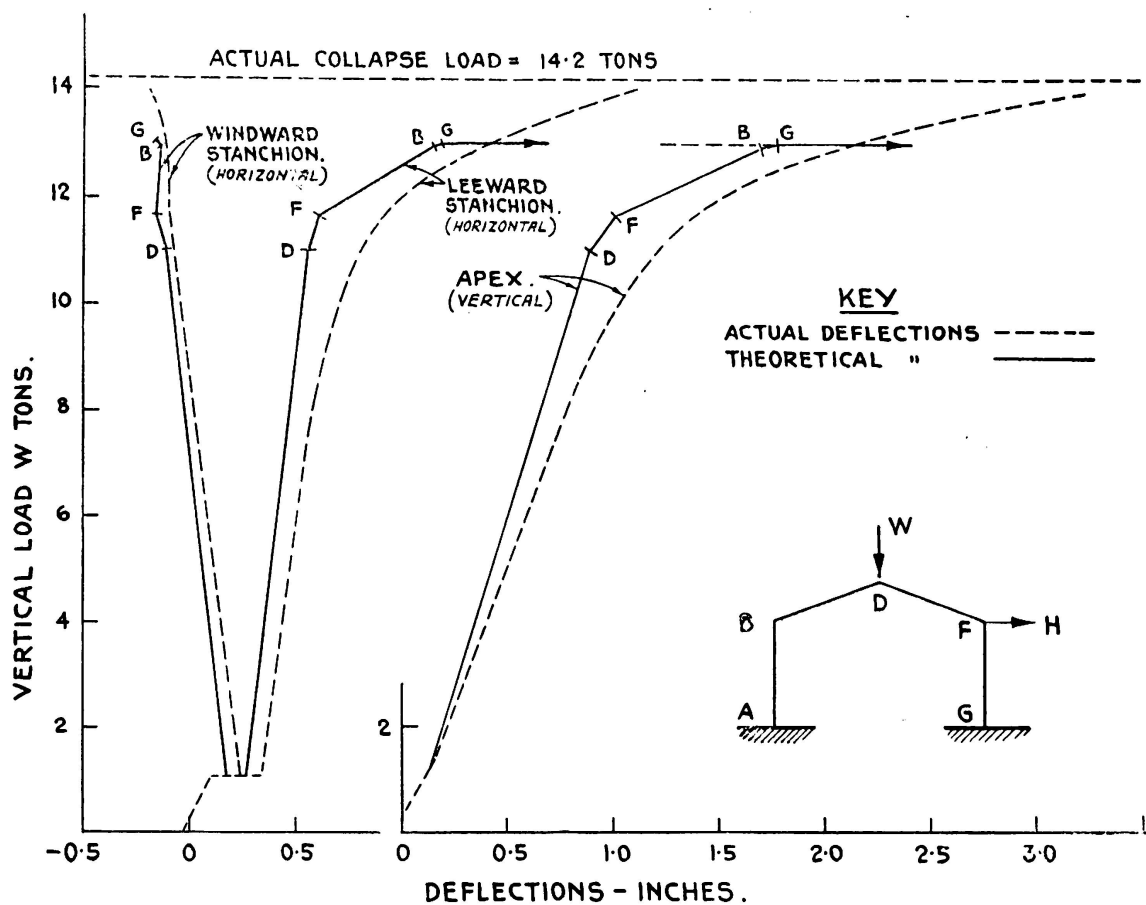

FIG. 5. Experimental and theoretical deflections of portal frame

order in which the resin cracks were observed was F, B, D, G, the theoretical order for the formation of the plastic hinges was D, F, B, G. The late recording of yield at D may have been due to the difficulties of observation (see Fig. 4 of authors' paper), and it is probable that yield did occur first at that section.

TABLE I

Summary of elastic-plastic analysis for pitched portal frames

Horizontal Load H (tons)	1.70	1.70	1.70	1.70	1.70	
Vertical Load V (tons)	0	11.02	11.66	12.93	12.95	
Positions of Plastic Hinges	-	D	D,F	D, F, B,	D, F, B, G	
Bending Moments (Tons Inches)	M _A	-43.5	56.7	69.0	81.0	83.8
	M _B	21.0	-164.2	-182.9	-247.0	-247.0
	M _D	13.9	247.0	247.0	247.0	247.0
	M _F	-43.2	-228.4	-247.0	-247.0	-247.0
	M _G	55.5	155.7	168.0	244.0	247.0
Hinge Rotations (Radians $\times 10^{-3}$)	θ_A	0	0	0	0	0
	θ_B	0	0	0	0	-0.92
	θ_D	0	0	3.74	20.12	21.38
	θ_F	0	0	0	-15.14	-16.14
	θ_G	0	0	0	0	0
Vertical Deflection at D (inches)	0.049	0.857	0.983	1.678	1.736	
Horizontal Deflection at B (inches)	0.206	-0.107	-0.156	-0.140	-0.162	
Horizontal Deflection at F (inches)	0.243	0.556	0.605	1.161	1.185	

REFERENCES

10. STEWART, R. W. — *Analysis of Continuous Structures by Traversing the Elastic Curves*. Trans. Amer. Soc. Civ. Engrs. 1936. Vol. 101, p. 105.

S U M M A R Y

The elastic traverse method of structural analysis is adapted to the calculation of deflections in rigid-jointed elastic-plastic structures at all stages up to plastic collapse. Theoretical results are obtained for the portal frame described by Baker and Eickhoff, and are compared with the experimental values.

ZUSAMMENFASSUNG

Die elastische Methode der Baustatik wird auf die Berechnung der Durchbiegungen von elastisch-plastischen Konstruktionen mit biegesteifen Stößen auf allen Stufen bis zum plastischen Bruchzustand angewendet. Die theoretischen Ergebnisse für einen Portalrahmen werden verglichen mit den experimentellen Werten.

R E S U M O

Aplica-se o método de cálculo elástico à determinação das flechas de estruturas elasto-plásticas com nós rígidos em todos os estados de equilíbrio até à rotura plástica. Comparam-se os resultados teóricos obtidos para o pórtico descrito por Baker e Eickhoff com os valores experimentais correspondentes.

R É S U M É

Les auteurs appliquent la méthode de calcul élastique à la détermination des flèches de charpentes elasto-plastiques à noeuds rigides dans tous les stades d'équilibre jusqu'à la rupture plastique. Ils comparent les résultats théoriques obtenus pour le portique décrit par Baker et Eickhoff avec les valeurs expérimentales correspondantes.