

Zeitschrift: IABSE congress report = Rapport du congrès AIPC = IVBH
Kongressbericht

Band: 5 (1956)

Rubrik: Free discussion

Nutzungsbedingungen

Die ETH-Bibliothek ist die Anbieterin der digitalisierten Zeitschriften. Sie besitzt keine Urheberrechte an den Zeitschriften und ist nicht verantwortlich für deren Inhalte. Die Rechte liegen in der Regel bei den Herausgebern beziehungsweise den externen Rechteinhabern. [Siehe Rechtliche Hinweise.](#)

Conditions d'utilisation

L'ETH Library est le fournisseur des revues numérisées. Elle ne détient aucun droit d'auteur sur les revues et n'est pas responsable de leur contenu. En règle générale, les droits sont détenus par les éditeurs ou les détenteurs de droits externes. [Voir Informations légales.](#)

Terms of use

The ETH Library is the provider of the digitised journals. It does not own any copyrights to the journals and is not responsible for their content. The rights usually lie with the publishers or the external rights holders. [See Legal notice.](#)

Download PDF: 19.11.2024

ETH-Bibliothek Zürich, E-Periodica, <https://www.e-periodica.ch>

Discussão livre

Discussion libre

Free Discussion

Freie Diskussion

Leere Seite
Blank page
Page vide

IV 1

Sea boring tower

Bohrturm im Meer

Torre para sondagens marítimas

Tour pour sondages à la mer

E. Mc. MINN

H. SHIRLEY SMITH

O. B. E., M. I. C. E., B. Sc.

London

The first Sea Boring Tower for coal ever constructed was commissioned by the National Coal Board and designed by Messrs. Maunsell, Posford & Pavry, to prove new coal seams by test borings, first in the Firth of Forth and then around the coasts of Britain. The main Contractors were The Cleveland Bridge & Engineering Co. Ltd. of Darlington, who supplied and fabricated the structural steelwork, with the exception of the tubular portion, and carried out the whole of the erection of the Tower and also the marine operations, including towing it out and lowering it to the bed of the estuary. The tubular steelwork of the 125 ft. high tower was designed and supplied by Tubewrights Ltd.

The tower is built on a cruciform base consisting of two all-welded steel box girders each 7 ft. deep, 3 ft. wide and 165 ft. long. These girders are temporarily connected below two all-welded pontoons from which they can be lowered by means of electric winches when the tower has been floated out to its position for boring. During floating out operations the pontoons are locked in position on either side of the tower by tubular steel booms.

At the top of the tower there are two octagonally-shaped decks 86 ft. wide. The 54 ft. high drilling rig which is operated by the Foraky Boring and Shaft Sinking Co. stands on the upper working deck which is also equipped with a workshop, pumphouse, engine room and 2-ton mobile crane. Round the perimeter of the lower deck are located the cabins, mess rooms and bath rooms, in prefabricated hutments capable of accommodating 25 men; in the interior are housed the generators and pumping and distillation plants.

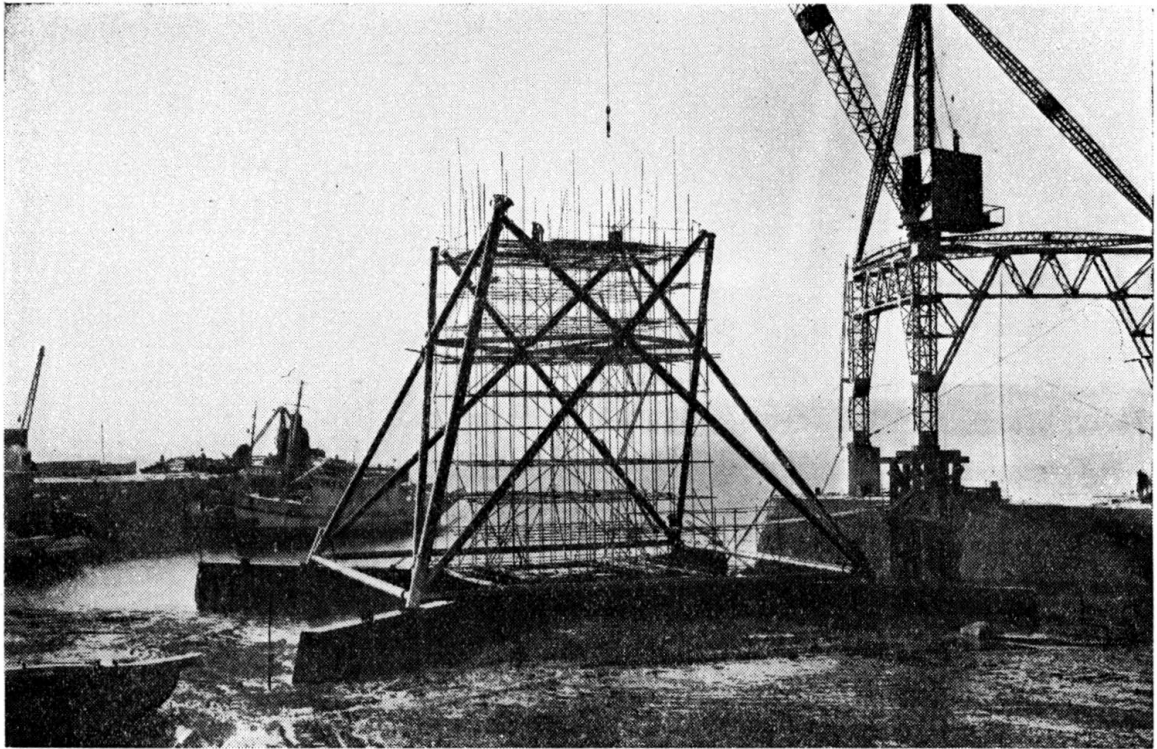

FIG. 1. Tubular steelwork being assembled, by 15-ton derrick, on cruciform base girders in St. David's Harbour

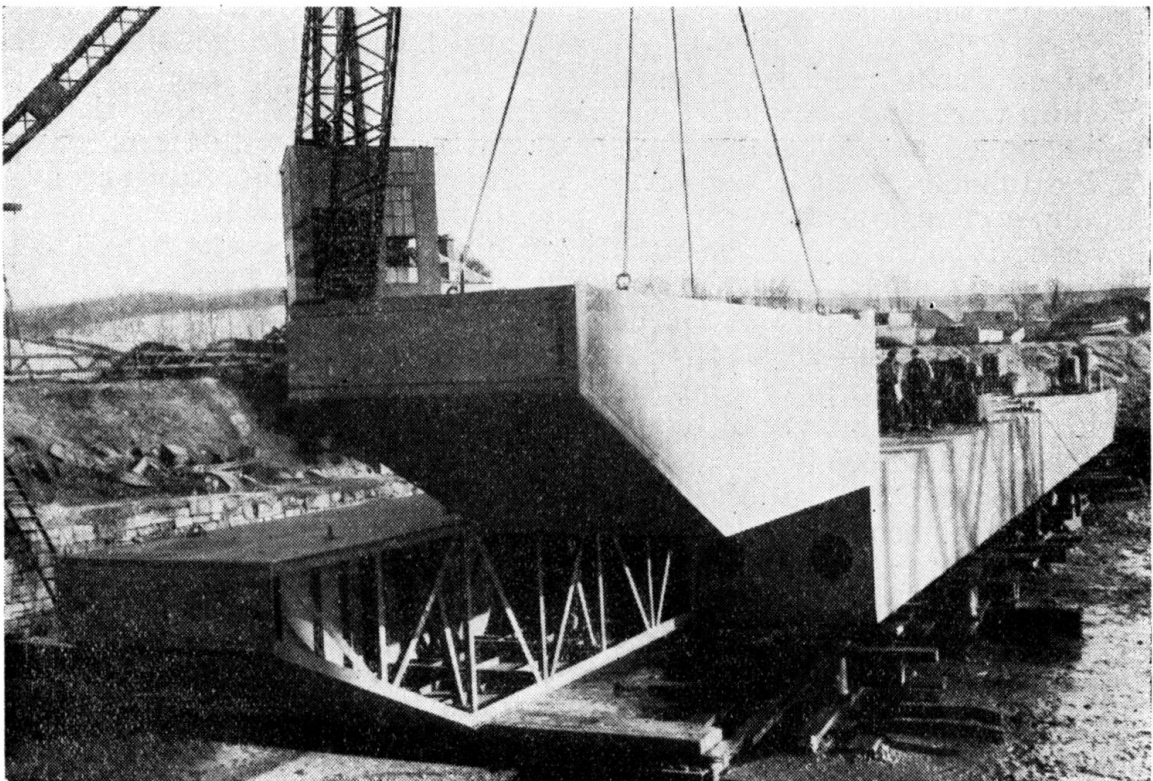

FIG. 2. Assembly of all-welded steel pontoons

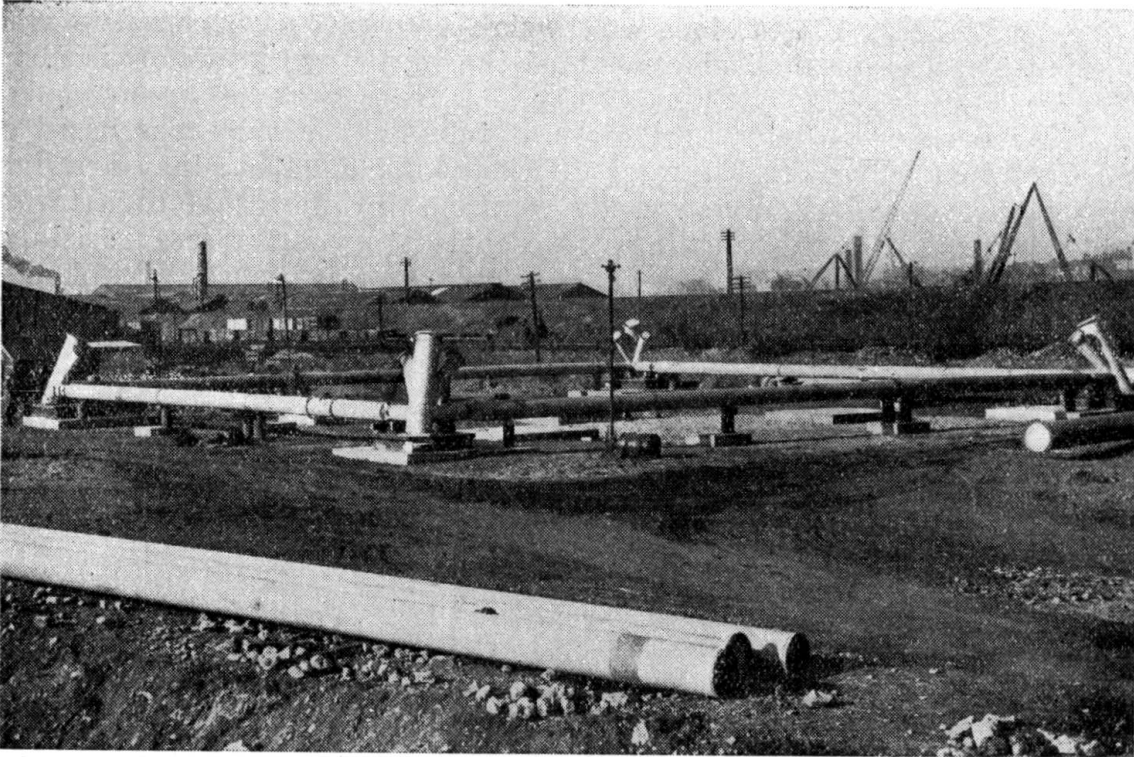

FIG. 3. Base unit of Tower erected at Messrs. Tubewrights' trial assembly site

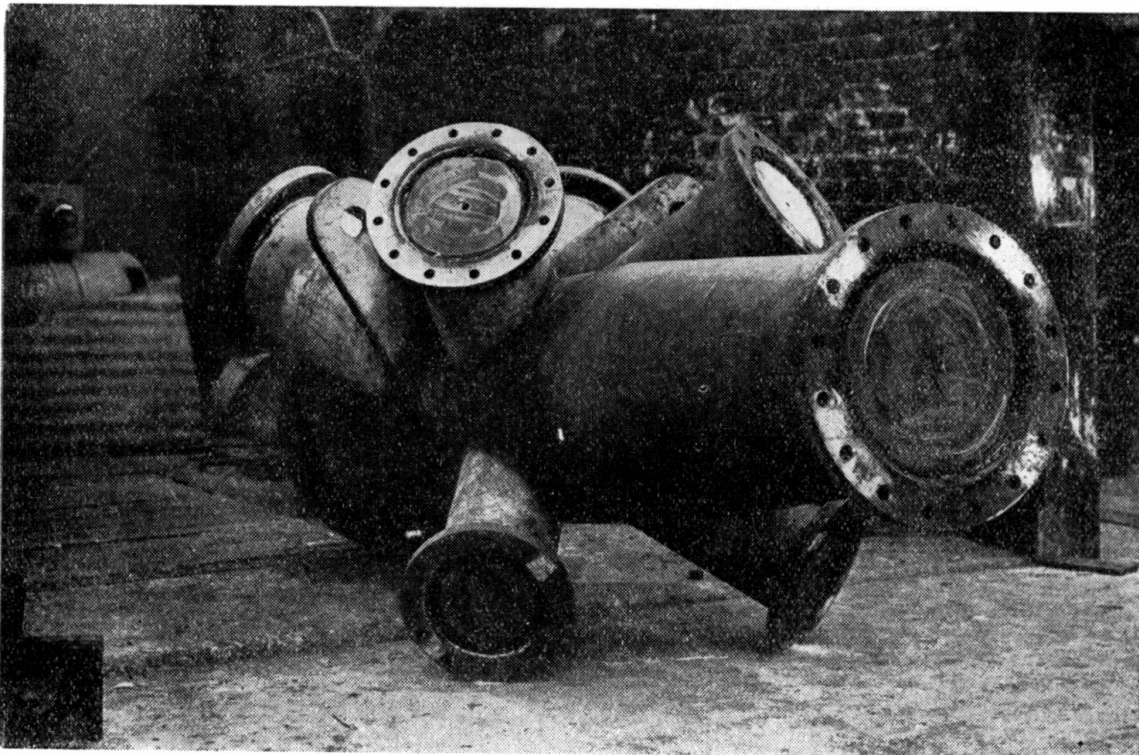

FIG. 4. Junction piece ready for completion of welding on blanking-off plates

The two all-welded pontoons used to transport the tower are $17\frac{1}{2}$ ft. wide, 7 ft. deep, 175 ft. long and weigh 180 tons each complete with equipment. The total displacement of the tower and pontoons is about 950 tons.

The decision to build the tower of tubular steelwork was based on the fact that tubes are the most efficient kind of strut; they are light in weight, strong, rigid and easily connected by means of high torque bolts through flanged couplings. Moreover, they offer less resistance than rolled steel sections to wave and wind forces; they can be blanked off for protection inside and the cylindrical outer surface lends itself

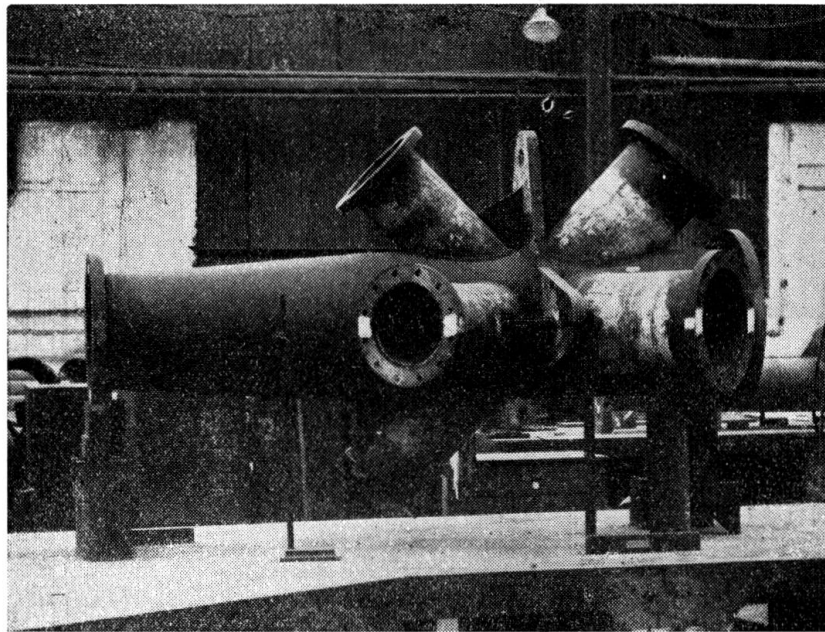

FIG. 5. Checking of heel plates after welding on junction piece

to easy maintenance. The main members are 24 ins. in diameter and the branch members 18 and 15 ins; where necessary short tapered sections are employed.

All the tubular members were fabricated and checked by shop assembly in Messrs. Tubewrights' Works. Although some connections had as many as ten tubes of varying diameter intersecting in different directions radially, the fabrication was so accurately carried out that all the 90 pieces fitted exactly and no adjustments whatever were needed during the site assembly. The tower was designed to withstand gales of 80 m. p. h. and waves 30 ft. high.

Work at St. David's Harbour, where the tower was erected, began in August 1954 and was completed in May 1955, when the tower was first floated, towed out and lowered on to its initial site. Before towing

the tower out, compressed air was pumped into the base girders to increase the buoyancy. The unit was towed by three Admiralty tugs with two more in attendance to provide restraint if necessary. At the end of their 12-mile journey the tugs were made fast to temporary

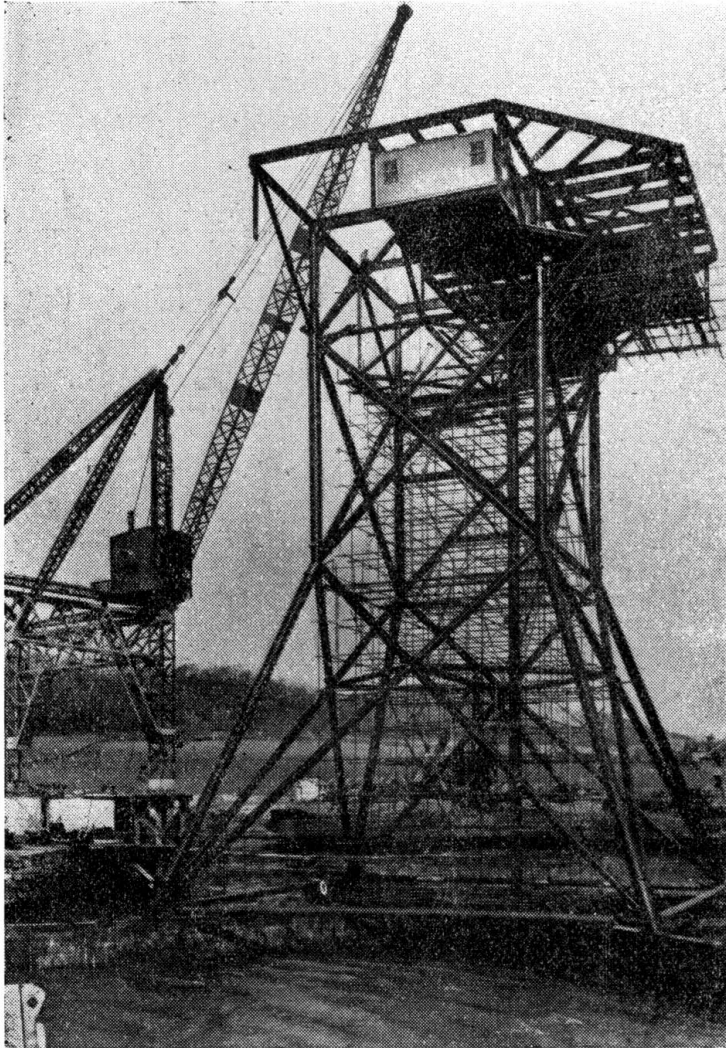

FIG. 6. Assembly of upper decks and accommodation units

moorings and the base girders of the tower were flooded and slowly lowered by means of four pairs of steel wire ropes of 8 inch circumference attached to the four lifting points. This operation was carried out by two 45-H. P. electrically driven winches on each pontoon. The tower was successfully lowered 12 fathoms to the bed of the estuary which had been checked for level in advance by means of echo soundings. The lowering ropes were disconnected and the pontoons returned to harbour.

The tower was then only three-quarters of a degree off vertical and drilling operations were commenced.

A year later, after completion of its first series of borings made to a depth of 3,000 ft. which disclosed the existence of five workable

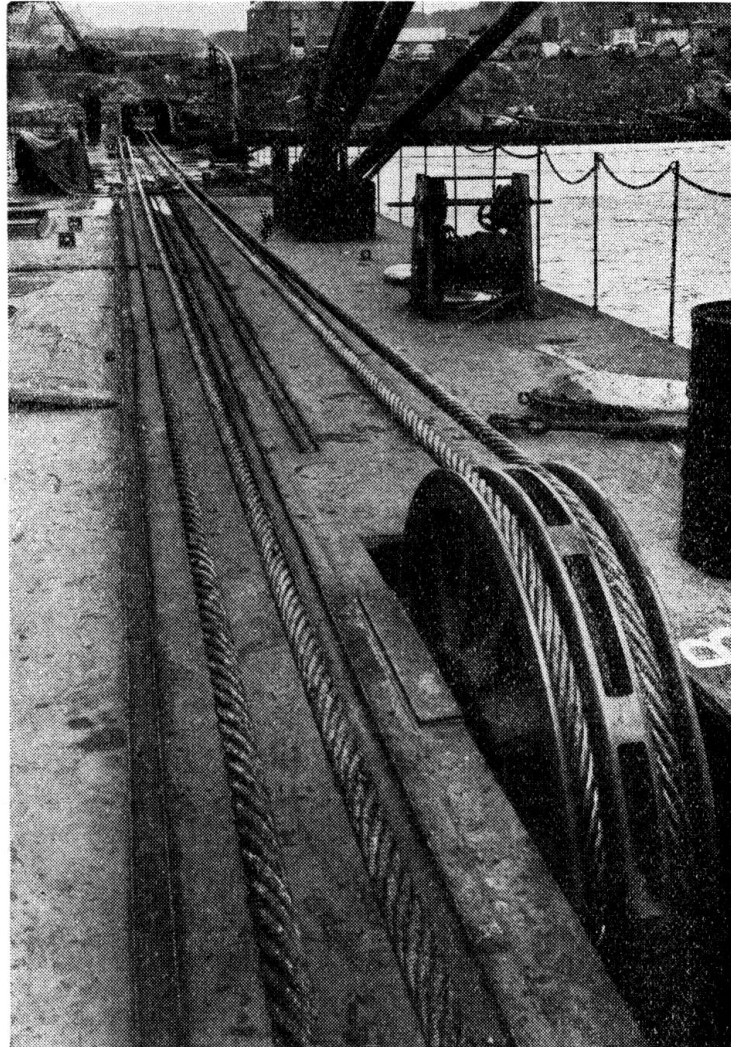

FIG. 7. 8-inch circumference lifting ropes and 5-ft. diameter sheaves on pontoon

seams, estimated to yield 40,000,000 tons of coal, the tower was uplifted by means of the same pontoons and winches which had been used to lower it. No difficulty was experienced in this operation and the tower was raised, moved to its new location and lowered again within a period of ten hours.

Apart from the drilling rig and the mobile crane, the whole of the power used for the services and operations is by electricity generated on

the tower. The three generators are driven by three 3-cylinder diesel engines which run at 500 r. p. m. and each develops 100 H. P. Connected in parallel, the generators give a total output of 150 kW. Fresh water for drinking and cooking is obtained by means of a vapour compressor

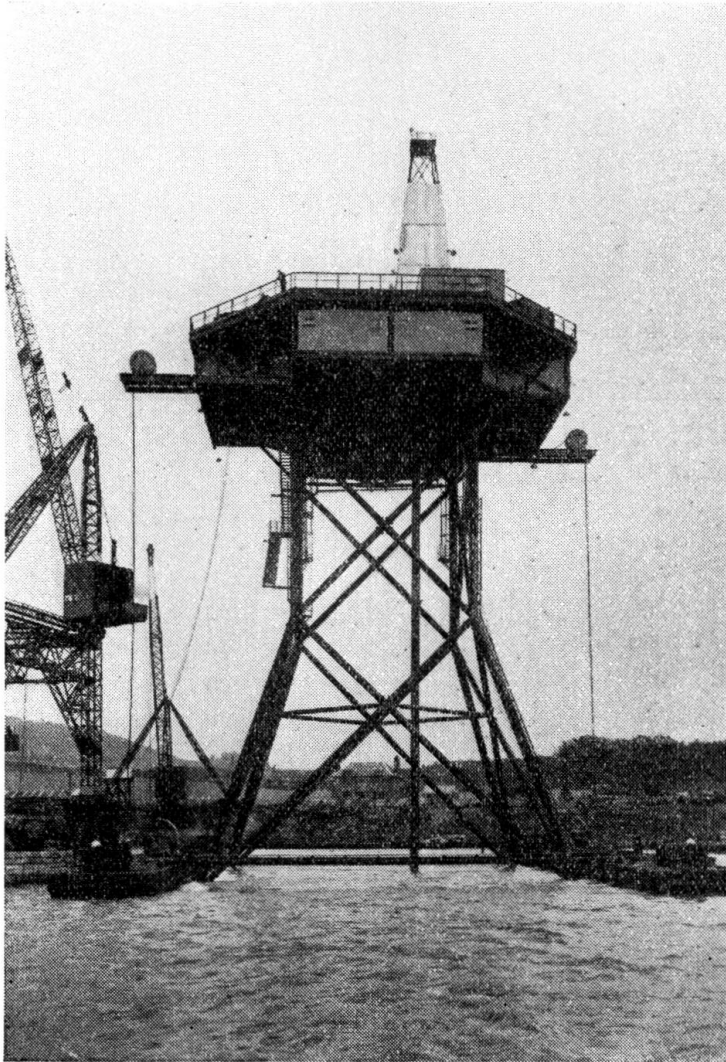

FIG. 8. Tower complete and ready for floating

unit which can produce 40 gallons of fresh water per hour from 70 gallons of salt water.

A radio telephone which operates at two frequencies and has a radius of ten miles is installed to maintain communication with the shore. The cost of the tower together with all its fittings, machinery and pontoons was of the order of £250,000 exclusive of the cost of boring.

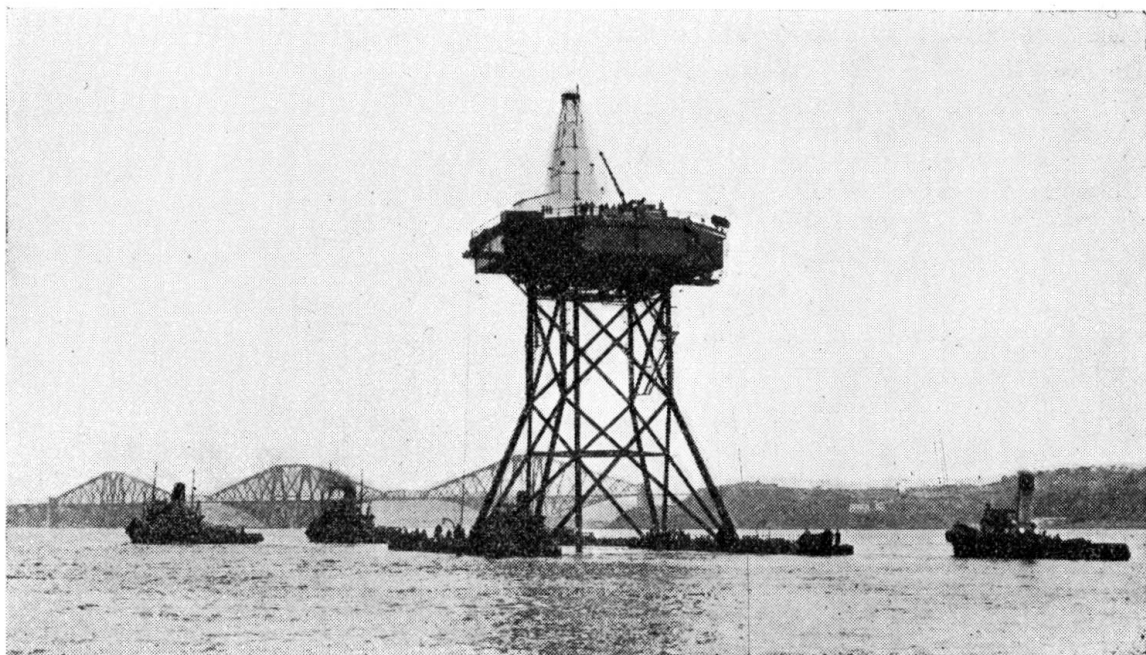

FIG. 9. Tower being towed out to its first drilling site



FIG. 10. Tower grounded in its first bering position in the Firth of Forth

SUMMARY

The authors describe the construction of the first sea boring tower ever built to prove new coal seams by test borings round the coasts of Britain. The tower was made of tubular steelwork connected by high torque bolts and was designed to be floated out and lowered to the sea bed for each series of borings.

ZUSAMMENFASSUNG

Die Verfasser beschreiben den Bau des ersten je gebauten Bohrturmes im Meer zur Erforschung neuer Kohlenflöze durch Probebohrungen an den Küsten Grossbritanniens. Der Turm wurde in Stahlrokonstruktion errichtet, wobei die Stahlrohre durch Drehzapfen miteinander verbunden wurden. Er wurde so entworfen, dass er auf einem Floss an Ort und Stelle gebracht und für jede Bohrung auf den Meeresgrund abgesetzt wurde.

RESUMO

Os autores descrevem a construção da primeira torre de sondagens marítimas destinada a prospectar jazigos de carvão por meio de furos de ensaio ao largo da costa britânica. A torre é constituída por uma estrutura tubular de aço, sendo as ligações asseguradas por parafusos especiais, sujeitos a um elevado binário à montagem, e foi projectada para ser rebocada até ao local e mergulhada até ao fundo para cada série de sondagens.

RÉSUMÉ

Les auteurs décrivent la construction de la première tour de sondages à la mer pour la prospection de gisements de charbon au moyen de forages d'essai, au large des côtes britanniques. Cette tour se compose essentiellement d'une structure en tubes d'acier liés au moyen de boulons à grand couple de serrage et a été étudiée pour être remorquée sur place et descendue au fond pour chaque série de sondages.

Leere Seite
Blank page
Page vide

IV 2

Design of light weight steel structures

Discussion

Zur Bemessung von Leichtbauten aus Stahl

Diskussion

Dimensionamento de estruturas ligeiras de aço

Discussão

Dimensionnement de charpentes légères en acier

Discussion

PROF. GEORGE WINTER

Cornell University

Ithaca

The writer is gratified that his 1948 tests on post-buckling effective width continue to be of interest to the profession. He is intrigued by, but cannot entirely agree with Professor Stüssi's re-evaluation of these tests.

It is quite true that an ideally plane plate, ideally supported and loaded and, in the case of steel, possessing a straight stress strain curve up to the yield point, should not buckle before its theoretical elastic critical stress σ_{cr} is reached, provided that stress is smaller than the yield point σ_{yp} . Furthermore, it was shown by the early tests of L. Schuman and G. Back in 1930 [1] that compressed plates do not fail at σ_{cr} but develop postbuckling strength. Th. v. Karman's semi-empirical formula of 1932, which is identical with Prof. Stüssi's Eq. 3, expresses these facts in terms of an equivalent width b_e and reads

$$\frac{b_e}{b} = \sqrt{\frac{\sigma_{cr}}{\sigma_{yp}}} \quad (a)$$

The sense of this equation can be understood as follows: A narrow, edgesupported, longitudinally compressed steel plate of thickness t with $\sigma_{cr} > \sigma_{yp}$ will fail by simple yielding at σ_{yp} . If t is kept constant and the width increased, the force F required to fail the plate increases proportional to the width b , but σ_{cr} correspondingly decreases until it becomes

equal to σ_{yp} . For this particular width b' the ideal plate will simultaneously buckle and yield ($\sigma_{cr} = \sigma_{yp}$). If the width is further increased, the force necessary to fail the plate remains constant and independent of b . In fact, from Eq. (a) and since $\sigma_{cr} = K (t/b)^2$

$$F = \sigma_{yp} t b_e = t^2 \sqrt{K \sigma_{yp}} = f(b)$$

or

$$b_e = t \sqrt{\frac{K}{\sigma_{yp}}} = f(b)$$

where K is a known constant which depends on the material, and edge conditions of the plate.

Tests by E. E. Sechler in 1933 [2] as well as the writer's tests in 1946 [3] and 1948 [4] have shown that this picture is oversimplified in two respects: (1) Real, rather than ideal, plates develop buckling waves at stresses below σ_{cr} and, therefore, are not fully effective ($b_e < b$) even though $\sigma_{cr} \geq \sigma_{yp}$, and (2) the effective width b_e for plates of width larger than b' does not remain constant but keeps increasing with increasing b' approaching the Karman value as an asymptote. The reason for the premature buckling, (1) above, is two-fold: (a) Real plates possess initial imperfections such as lack of flatness and/or eccentricity of loading which, as in columns, produce premature waving; this influence has been investigated by Hu, Lundquist and Batdorf [5] and was found to be sizeable, as is seen from Fig. 1. (b) While for steel E is assumed to be constant up to σ_{yp} and b_e is computed on this basis, in actuality residual stresses introduced by the sheet rolling process and by coldforming of sections produce a lowering of the effective proportional limit and therefore a decrease in the effective modulus for stresses larger than this proportional limit. This, in turn, reduces σ_{cr} and b_e . Since both these effects are irregular and accidental, they produce an irregular downward scattering. On the other hand, compression plates which are not isolated but are parts of structural sections, such as those tested by the writer, have some rotational restraint along their edges and for this reason their effective width tends to be larger than the usual expression for b_e for hinged edge support.

In view of the complexity of this situation, and the necessity of furnishing the light gage steel construction industry with a relatively simple and reliable design formula, the writer has developed his purposely conservative equation for b_e , based on his 1946 and 1948 tests as well as on those of Sechler. As early as 1949 [6] he gave a graphical presentation of these results whose form, except for the denominator 1.9 in the abscissas, is identical with that now given in Prof. Stüssi's figure. It is reproduced here unchanged as Fig. 1. This figure contains not only the 45 points of the writer's 1948 publication which have been used by Prof. Stüssi, but also the 26 points of his 1946 paper. It is seen that the v. Karman expression, represented by the inclined straight line and the horizontal line with ordinate 1.0, is close to an upper limit of the test results; the points which lie above that line are due to sizeable edge restraints of larger magnitude than is found in many shapes

currently in use. On the other hand, the writer's curve is seen to be close to a lower limit of the test points, as is appropriate for a design determination which must be safe even for minimum edge restraint. Also shown is one calculated curve for an initial distortion of the plate equal to one-tenth of the plate thickness, i. e. of very small amount. It is seen that, according to Hu, Lundquist and Batdorf, even such a small amount reduces the equivalent width b_e noticeably. (These authors assumed the shape of initial distortion to be affine to that of the buckling surface; this will not usually be the case, which reduces the effect of initial distortion. On the other hand, in light gage steel constructions initial distortions of the order of $t/2$ and more are not uncommon, compared to $t/10$ for the curve on Fig. 1).

The largest difference between test results and the writer's equation on the one hand, and v. Karman's (and Prof. Stüssi's) expression on the other, occurs in the region where the actual stress in the plate is about

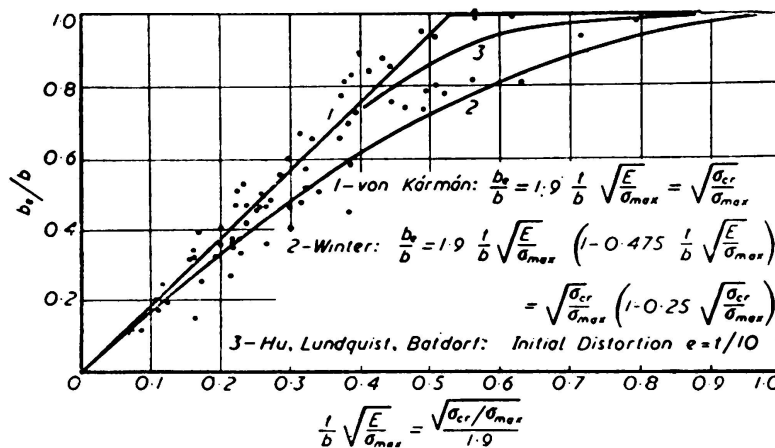

FIG. 1

equal to σ_{cr} . While Eq. (a) indicates that $b_e = b$ if $\sigma_{cr} = \sigma_{yp}$, the tests definitely show that for such plates $b_e < b$ even though the actual plate stress is equal to or even smaller than σ_{cr} . This factor is more pronounced in the writer's 1946 tests with their relatively low b/t ratios i. e. relatively high σ_{cr} , than in his 1948 tests with their larger b/t and therefore much lower σ_{cr} . The fact that Prof. Stüssi analyzed only these latter tests may have mislead him somewhat.

It is not maintained that the writer's generalized expression

$$\frac{b_e}{b} = \sqrt{\frac{\sigma_{cr}}{\sigma_{max}}} \left(1 - 0.25 \sqrt{\frac{\sigma_{cr}}{\sigma_{max}}}\right) \tag{b}$$

which holds not only for the yield point but for any plate stress σ_{max} provided $\sigma_{cr}/4 \leq \sigma_{max} \leq \sigma_{yp}$, is in any way theoretically rigorous. On the contrary, its aim is to represent reasonably well and somewhat conservatively the behavior of real compression plates which are part of real, light-gage, cold-formed steel members with all the random irregularities

which this implies. It might be added that essentially this same expression has been officially in use in the U. S. A. light gage steel industry for about ten years, and that very numerous tests have been carried out by various companies to compare the performance (strength as well as deflections) of their own products with that predicted by this formula, with uniformly satisfactory results.

It should be stated at the same time that, even though the writer's formula is sometimes used in the aircraft industry, it was not originally meant to apply to non-ferrous metals with their lower E, their different stress-strain curve and residual stress properties and their artificially defined yield stress (Prof. Stüssi's σ_F). All these result in an effect of deviations from ideal conditions which is different from that which obtains in light-gage steel members as tested by the writer and reflected in his formula.

1. L. SCHUMAN and G. BACK—*Strength of Rectangular Flat Plates under Edge Compression*. Nat. Adv. Comm. for Aeronautics, Report No 356, 1930.
2. E. E. SECHLER—*The Ultimate Strength of Thin Flat Sheet in Compression*. Guggenheim Aeronaut. Labr., Calif. Inst. of Techn., Publ. No. 27, 1933.
3. GEO. WINTER—*Strength of Thin Compression Flanges*. Trans. ASCE, vol. 112, p. 527, 1947, also Proc. ASCE vol. 72, No. 2, p. 199, 1946.
4. GEO. WINTER—*Performance of Thin Steel Compression Flanges*. 3rd Congress IABSE, Prelim. Publ., p. 137, Liège, 1948.
5. P. C. HU, E. E. LUNDQUIST, S. B. BATDORF—*Effect of Small Deviations from Flatness on Effective Width and Buckling of Plates in Compression*. Nat. Adv. Comm. for Aeronautics, Techn. Note No. 1124, 1946.
6. GEO. WINTER—*Performance of Compression Plates as Parts of Structural Members*, Research, Engineering Structures Supplement (Colston Papers, vol. II) p. 179, London, 1949.

SUMMARY

While v. Karman's semi-empirical post-buckling equation, which is identical with Prof. Stüssi's, is well justified for «ideal» conditions, compression plates which are parts of «real» steel structures show two types of imperfections: deviations from flatness and residual stresses caused by cold-forming which are equivalent to a lowered proportional limit. These reduce the post-buckling strength. On the basis not only of his 1948 tests but also of his 1946 tests and those of Sechler it is shown that the writer's formula for effective width, which has been in wide use in the U. S. A. for over ten years, represents conservatively and more realistically the behaviour of real, light-gage steel structures.

ZUSAMMENFASSUNG

Während v. Karmans Gleichung für überkritisches Beulen, welche mit derjenigen Prof. Stüssi identisch ist, gut gerechtfertigt ist für «ideale» Platten, so zeigen Druckplatten, welche Teile von wirklichen Stahlleichtbauten sind, zwei Arten von Unvollkommenheiten: Abweichung von der Ebenheit und Eigenspannungen die zu einer Erniedrigung der Proportionalitätsgrenze führen. Beide vermindern die überkritische Beulfestigkeit. An Hand nicht nur seiner 1948 Versuche, sondern auch derer

von 1946, sowie auch derjenigen von Sechler, ist gezeigt, dass des Verfassers Gleichung für die wirksame Breite, welche in den Vereinigten Staaten seit zehn Jahren weite Verwendung findet, das Verhalten wirklicher Stahleichtbauten mehr konservativ und realistisch darstellt.

RESUMO

Ao passo que a utilização da equação semi-empírica de von Karman referente à encurvadura, e que é aliás idêntica à do Prof. Stüssi, se justifica em casos «ideais» de aplicação, o mesmo não acontece com placas comprimidas fazendo parte de estruturas de aço «reais» que apresentam imperfeições de dois tipos: empenos e tensões residuais provenientes da laminagem a frio que equivalem a um abaixamento do limite de proporcionalidade. Estas imperfeições reduzem a resistência da placa encurvada. Baseando-se não só nos ensaios que efectuou em 1948 e 1946, mas também nos de Sechler, o autor mostra que a sua fórmula de determinação da largura efectiva, já largamente utilizada nos E. U. A. há mais de dez anos, representa de maneira mais conservadora e realista o comportamento das estruturas de aço de pequena espessura.

RÉSUMÉ

Tandis que l'emploi de l'équation semi-empirique de von Karman, valable pour le stade post-flambage, et qui est d'ailleurs identique à celle du Prof. Stüssi, est justifié dans les cas «idéaux» d'application, il n'en est pas de même dans le cas de plaques comprimées faisant partie de charpentes «réelles» qui présentent deux types d'imperfections: des gauchissements et des contraintes résiduelles provenant du laminage à froid et qui équivalent à une diminution de la limite de proportionnalité. Ces imperfections réduisent la résistance de la plaque après le flambage. En se fondant, non seulement sur les essais qu'il a effectué en 1948 mais aussi sur ceux de 1946 et ceux de Sechler, l'auteur montre que sa formule de détermination de la largeur effective, couramment utilisée aux E. U. A. depuis plus de dix ans, représente d'une façon plus conservatrice et plus réaliste le comportement des charpentes en acier de faible épaisseur.

Leere Seite
Blank page
Page vide

IV 3

Maintenance of steel structures

Discussion

Unterhalt von Stahlbauten

Diskussion

Conservação das construções metálicas

Discussão

Entretien des charpentes métalliques

Discussion

P. S. A. BERRIDGE

M. B. E., M. I. C. E.

London

Mr. BERRIDGE remarked that he could not agree with the author's contention that loose rivets could be tightened by welding round the heads. The number of tests, four, was inadequate to form the basis for so far-reaching a claim contrary to the principles of both riveting and welding. The heat from the welding was bound to lengthen the shank of a rivet and so reduce the friction between the faying surfaces of the parts joined. The clamping effect of the rivet caused by contraction of the shank on cooling immediately after driving was of primary importance in the transfer of shear across a joint; and, if there was a loss of this clamping effect as would be indicated by looseness, no amount of welding round the head was ever likely to restore the high degree of friction required to keep the parts from slipping under the application of a shearing force.

Mr. BERRIDGE showed slides (not reproduced) indicating how by simple modifications the maintenance of the girderwork of steam locomotive turntables built some 50 to 60 years ago for a railway in India had been greatly simplified and the future life of the steelwork extended. The rails had been lifted on steel packings; the solid plate deck between the girders had been replaced with an open grill; the outside deck plating had been kept clear of the girder flanges, and the edge angles which used to contain water on the plating had been inverted. These modifica-

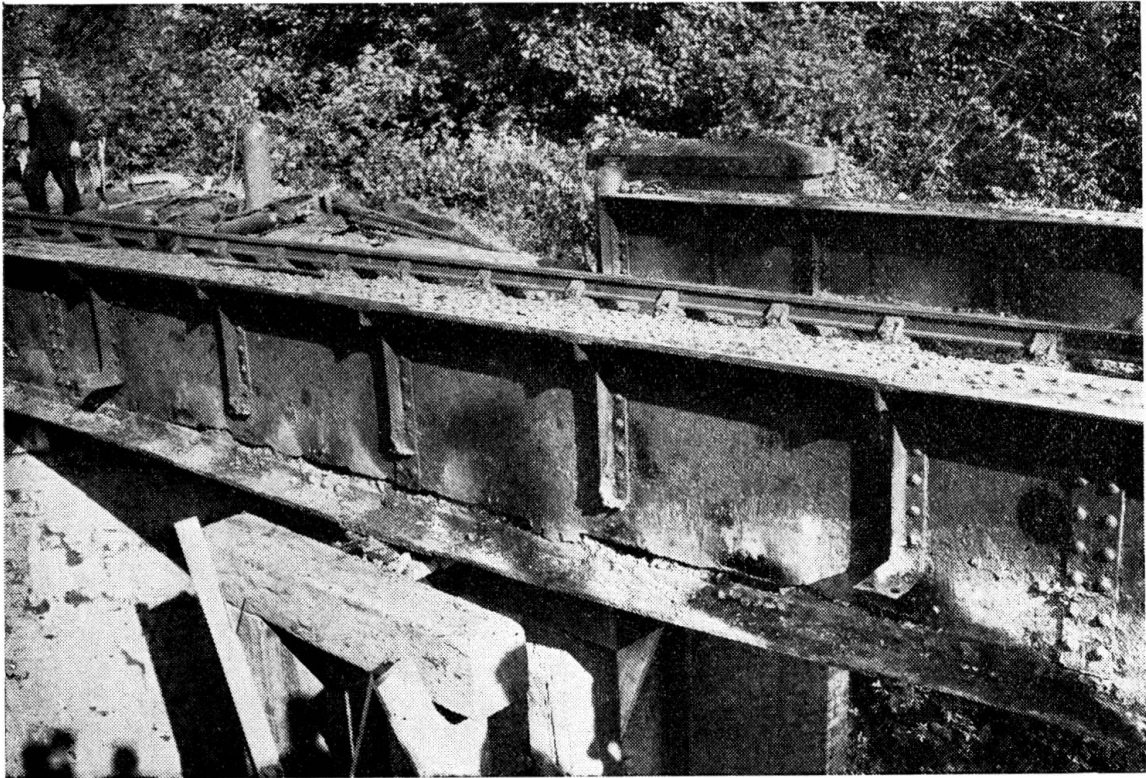

FIG. 1. The failure of a plate girder caused by corrosion fatigue of the mild steel web which had been obscured by concrete haunching. The decking on the nearside of the girder had been removed before this photograph was taken

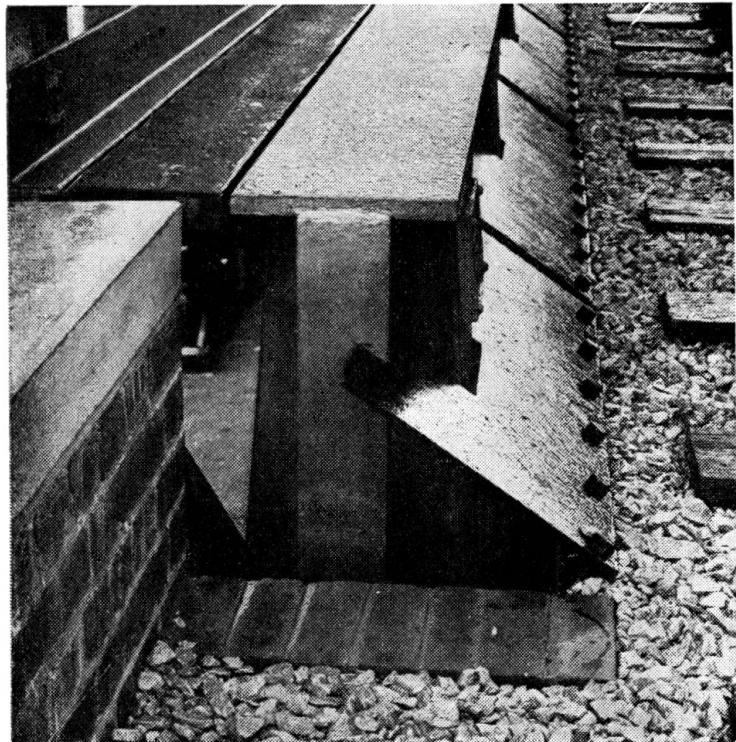
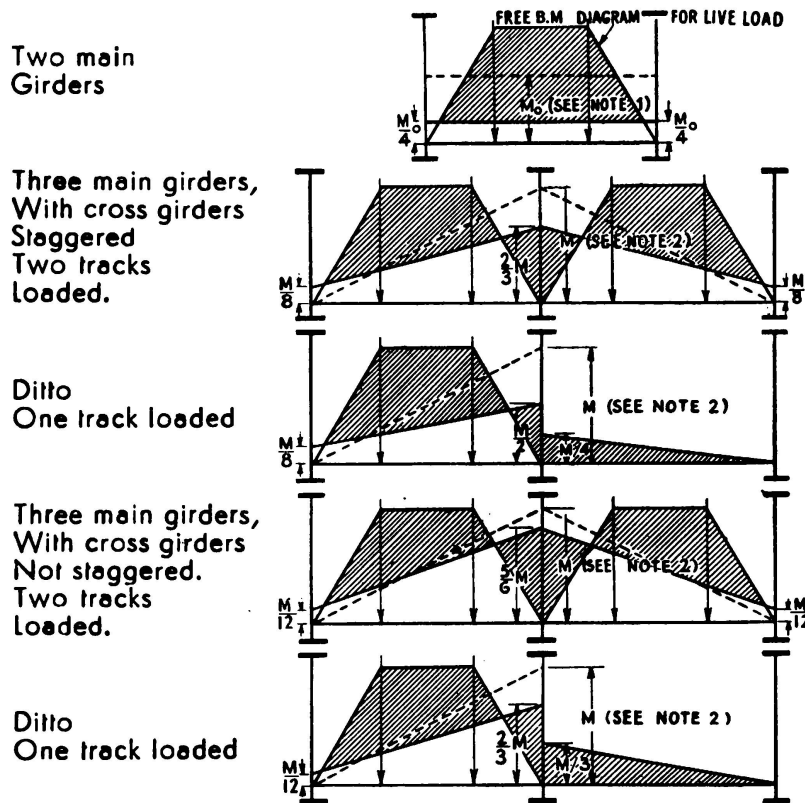

FIG. 2. The end of a welded plate girder showing how, by the removal of the bolted weather plates, full access is given to the joints between the deck units and the main girders

tions had made all parts fully accessible for painting and had, by allowing free circulation of air between the girders, removed a condition which had previously been very favourable to the propagation of rust.

Turning to the importance of accessibility for the proper maintenance of railway girder bridges, Mr BERRIDGE showed a picture (Fig. 1) of a centre girder of a double track half-through type plate girder span which through corrosion fatigue had developed a crack in the web plate



NOTES:—1. For bridges with two main girders, and when gross girder is symmetrically loaded, M_0 = average height of free B. M. diagram.
 2. For bridges with three main girders, M = end moment for full fixity at centre girder. (When loading is symmetrically placed on either or both cross girders, M = 1.5 times the average height of the free B. M. diagram).

FIG. 3. Diagram indicating the end fixing moments on cross girders in half-through type spans

at a point just above the bottom flange angles. The crack had extended over a length of 19 feet in a 30-foot span. The primary cause had been the masking of the girder by concrete haunching placed against the web with the object of reducing maintenance work. Damp had got down between the concrete and the steel web plate with the result that corrosion had set in where it was wholly obscured from view. The decking was of transverse steel troughing resting on the bottom flanges of the girders

and the web stiffeners stopped on the top of the troughing so that there was in fact no connection between these stiffeners and the bottom flange of the girder. Alternations of loading by the passage of trains, first on one track, and then on the other, had led to high concentrations of stress on the web plate at a point immediately above the flange where moisture was trapped behind the concrete. To guard against such a failure it was imperative that the all-important connections between decking and main girders should be wholly accessible for inspection and painting; no concrete should be placed against steelwork unless it was absolutely certain that no moisture could get down between the concrete and the steel. Showing a slide (Fig. 2) he indicated how bolted joints between deck units and the main girders of a bridge carrying a ballasted sleeper track could be made fully accessible for maintenance. On the subject of the connections between cross girders, deck units, etc. and main girders in half-through type spans, Mr BERRIDGE showed a diagram (Fig. 3) indicating the bending moments caused by the end fixity of the deck members. In the past so many bridges had been built on the assumption that cross girders were simple beams unrestrained at the ends. Such an assumption was quite wrong when, as generally happened, some degree of fixity became inevitable in designing the connection between a cross girder and the side of a plate girder. In the joint just visible below the weather plates (Fig. 2) the moment stresses due to end fixity were taken by high strength bolts connecting the deck units to the sloping flanges of web stiffeners on the main girders.

SUMMARY

The author said that loose rivets could not be tightened by welding round the heads. Such process was contrary to good practice.

Stressing the importance of accessibility, the author instanced (Fig. 1) a double track half-through type plate girder bridge where concrete haunching against the web of the middle girder had prevented the detection of a serious corrosion fatigue fracture of the web plate.

Improvements in the connections of deck units to main girders were shown (Fig. 2); attention was focused on the importance of designing such joints to carry the stresses induced by the end fixing moments inevitable wherever there is end restraint (Fig. 3).

ZUSAMMENFASSUNG

Der Verfasser ist der Auffassung, dass lose Nieten nicht durch Anschweißen der Nietköpfe befestigt werden könnten. Dieses Vorgehen widerspricht einer guten Praxis.

Als Beispiel für die Bedeutung guter Zugänglichkeit führt der Verfasser einen Vollwandträger für eine zweigleisige Brücke mit einer in Trägermitte liegenden Geleisewanne in Beton an. Der an den Steg des mittleren Trägers anstossende Beton hatte die Entdeckung eines ernsthaften Ermüdungsbruches infolge Korrosion verhindert (Fig. 1).

Es wurden Verbesserungen gezeigt bei den Verbindungen zwischen Deckenplatten und Hauptträgern (Fig. 2); besondere Aufmerksamkeit wurde der Bedeutung des Entwurfes von Verbindungen geschenkt, die die Beanspruchungen durch Endeinspannungsmomente, die unvermeidlich auftreten, wo immer das Endauflager an der freien Beweglichkeit gehindert ist, aufzunehmen haben (Fig. 3).

RESUMO

O autor indica que os rebites frouxos não se podem voltar a apertar soldando as cabeças, indo este processo contra boa técnica.

Insistindo na importância da acessibilidade, o autor cita o exemplo (Fig. 1) de uma ponte de via dupla com vigas semi-contínuas de alma cheia, em que a acumulação de betão contra a alma da viga central impediu a verificação de uma fractura importante da alma devida à corrosão.

O autor mostra como se pode melhorar a ligação do tabuleiro às vigas principais (Fig. 2) e chama a atenção para a necessidade de projectar estas ligações de modo a que possam suportar as tensões produzidas pelos momentos devidos à imobilização das extremidades, inevitáveis quando existe uma limitação do movimento das mesmas.

RÉSUMÉ

L'auteur indique que les rivets desserrés ne peuvent être réparés par la soudure des têtes, ce procédé étant contraire à la bonne pratique.

En insistant sur l'importance de l'accessibilité, l'auteur cite l'exemple (Fig. 1) d'un pont à double voie, à poutres semi-continues à âme pleine, dans lequel l'accumulation de béton contre l'âme de la poutre médiane a empêché de constater l'existence d'une fracture importante de l'âme due la corrosion.

L'auteur montre comment il est possible d'améliorer la liaison du tablier aux poutres-maîtresses (Fig. 2); il fait remarquer qu'il est nécessaire de calculer ces liaisons de manière à ce qu'elles puissent supporter les contraintes produites par les moments dûs à l'immobilité des extrémités, inévitables chaque fois qu'il existe une limitation du mouvement de ces extrémités.

Leere Seite
Blank page
Page vide

IV 4

Calcul des âmes des poutres en alliages légers

Discussion

The design of the webplates of light alloy plate girders

Discussion

Die Berechnung der Stehbleche von Leichtmetallträgern

Diskussion

Cálculo das almas das vigas de ligas leves

Discussão

CH. MASSONNET

Professeur à l'Université de Liège

Liège

Nous voudrions tout d'abord complimenter M. ROCKEY pour le soin avec lequel il a réalisé ses essais, soin qui a pour conséquence une dispersion remarquablement faible des charges critiques expérimentales, qui ressort des figures 2 et 3 de son mémoire.

1. Nécessité d'un raidissage de l'âme des poutres à âme pleine

Nous sommes en général d'accord avec les opinions émises par M. ROCKEY. Le seul point sur lequel nous croyons devoir faire quelques réserves est l'affirmation faite à la page 610 de son mémoire selon laquelle le rapport de la charge de service d'une âme raidie à sa charge critique dépend plus de considérations esthétiques que de conditions de tension. En attachant à cette affirmation un sens trop absolu, on serait amené à prétendre que le danger de voilement n'existe pas et que l'on peut se passer de raidisseurs; ou tout au moins, que la sécurité est assurée quand on a disposé sur la poutre un certain nombre de raidisseurs verticaux destinés à former, avec les semelles et l'âme plissée diagonalement, un «treillis Wagner». Ces opinions sont fausses et la preuve en est que, par un raidissage horizontal convenable, nous avons pu, dans nos expériences, relever de plus de vingt pour cent la charge ultime de nos poutres d'essai ⁽¹⁾.

⁽¹⁾ Voir à ce sujet: Ch. Massonnet: Essais de voilement sur poutres à âme raidie — Mém. A. I. P. C., vol. XIV, 1954, pp. 125-186.

En réalité, l'âme voilée exerce sur la semelle comprimée de la poutre (fig. 1) des tensions verticales qui peuvent hâter considérablement le flambement de cette semelle dans le plan de l'âme.

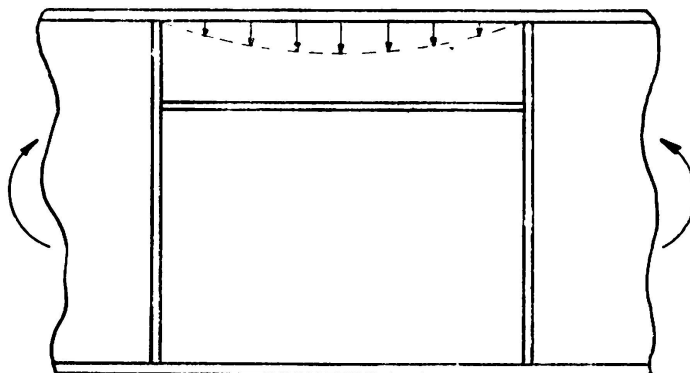

FIG. 1

Par un raidissage horizontal convenable de la partie comprimée de l'âme, la croissance de ces tensions est retardée à un point tel que la semelle ne périt qu'au moment où elle est entièrement plastifiée.

2. Nécessité de donner à la semelle comprimée une grande rigidité

Le raisonnement précédent montre que, pour réaliser la poutre la plus rationnelle, il faut, non seulement raidir son âme, mais encore veiller à donner à la semelle comprimée une grande stabilité propre. Ce résultat peut être atteint par le profil de la figure 2a, dont les essais sur poutres

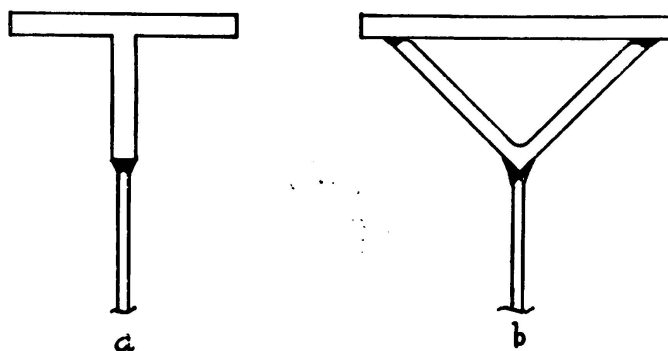

FIG. 2

soudées de MACKEY et BROTON ont montré tout l'intérêt, et mieux encore par le profil figure 2b, dont l'idée est due au professeur DÖRNEN. Ces deux formes de membrure ont une importante vertu supplémentaire, qui est de réaliser un encastrement quasi-parfait des panneaux d'âme.

Notons, à ce propos, que, dans les poutres rivées de M. ROCKEY, les cornières âme-semelle réalisaient un encastrement considérable des pan-

neaux d'âme, comme dans le type de poutre expérimenté par MACKEY et BROTON. Dans nos propres essais, au contraire, le soutien réalisé par les semelles était beaucoup plus faible.

L'évolution des formes constructives signalée ci-dessus démontre aussi l'impérieuse nécessité où l'on est de disposer d'un ensemble complet de valeurs numériques théoriques des tensions critiques de plaques encastrees sur leurs bords, raidies ou non. Nous indiquons d'autre part⁽²⁾ le principe d'une méthode théorique qui permettra d'obtenir de telles valeurs avec l'assistance d'une machine calculatrice électronique pour l'exécution des calculs numériques.

Par ailleurs, notons que la Commission Belge pour l'Etude de la Construction Métallique (C. E. C. M.) a inscrit à son programme des essais sur poutres soudées type Dörnen, qui doivent être exécutés prochainement.

3. Possibilités de transposer les résultats obtenus par M. ROCKEY aux poutres en acier

A) Résultats concernant le dimensionnement de l'âme

Il importe de souligner la différence, à notre avis essentielle, entre les essais de M. ROCKEY et les nôtres. Ses essais sont exécutés sur un alliage d'aluminium dont le rapport: limite élastique (R_e) sur module d'élasticité (E) vaut $\frac{23,6}{7000} = 3,4 \cdot 10^{-3}$. Pour l'acier 37, sur lequel nous avons expérimenté, le même rapport vaut $\frac{R_e}{E} = \frac{24}{21.000} = 1,14 \cdot 10^{-3}$, c'est-à-dire le tiers seulement de la valeur précédente.

Cet écart a d'autant plus d'importance que la limite d'étirage R_e de l'acier A 37 est accompagnée de déformations plastiques considérables provoquant nécessairement la ruine de la pièce, tandis que la limite élastique de l'alliage d'aluminium est une limite conventionnelle à 0,2 %, cet alliage ne possédant pas de palier marqué de plasticité.

Or, on a

$$\sigma_{cr} = k \frac{\pi^2 D}{b^2 e} = k \frac{\pi^2 E}{12 (1 - \eta^2)} \left(\frac{a}{b}\right)^2$$

D'où

$$\frac{R_e}{\sigma_{cr}} = \frac{12 (1 - \eta^2)}{k \pi^2} \left(\frac{b}{e}\right)^2 \frac{R_e}{E} = \frac{1,1}{k} \left(\frac{b}{e}\right)^2 \frac{R_e}{E}$$

Il est clair, dès lors, que toutes choses égales d'ailleurs, le domaine post-critique élastique est beaucoup plus étendu dans les poutres en alliage l'aluminium que dans celles en acier A. 37. C'est la raison pour laquelle M. ROCKEY obtient pour le rapport $\frac{P_{critique}}{P_{ultime}}$ des valeurs comprises entre 4 et 8, tandis que dans nos expériences, ce rapport était généralement compris entre 2 et 4.

(2) Contribution au thème IIb: Théorie générale du voilement des plaques rectangulaires encastrees ou appuyées sur leurs bords et renforcées par des raidisseurs parallèles aux bords résistant à la flexion et à la torsion.

Ces considérations expliquent qu'il est nécessaire, dans les poutres à âme pleine en alliage d'aluminium, de travailler en service dans le domaine postcritique, comme le préconise M. ROCKEY, qui propose un coefficient de sécurité au voilement inférieur à l'unité ($1/1,5 = 0,667$).

Nous avons proposé, au Congrès de Cambridge de l'A. I. P. C., d'adopter comme coefficients de sécurité 1,15 vis-à-vis du voilement par flexion et 1,35 vis-à-vis du voilement par cisaillement. Nous avons indiqué ultérieurement que l'on pouvait descendre sans inconvénient jusqu'à l'unité. Même en adoptant cette dernière valeur, le rapport des sécurités vaut environ 2 parce que M. ROCKEY base ses tensions critiques sur l'hypothèse d'un demi-encastrement tandis que nous adoptons les valeurs de TIMOSHENKO relatives à une plaque simplement appuyée sur ses bords

$$\text{En effet } \frac{s \text{ Massonnet}}{s \text{ Rockey}} \text{ vaut } \frac{1}{0,667} \times \frac{32,75}{23,9} = 1,96 \approx 2.$$

Cependant, les élancements b/e des tôles mises en œuvre sont pratiquement les mêmes dans les deux cas, vu l'effet du faible module E de l'aluminium. La discussion qui précède conduit à une conclusion importante, à savoir que toutes choses égales d'ailleurs, le coefficient de sécurité devrait varier dans le sens opposé au rapport R_e/E ; en particulier, il pourrait être choisi moindre dans le cas de l'acier A. 52 (pour lequel $R_e/E = 1,71 \cdot 10^{-3}$) que pour l'acier A. 37, ce qui permettrait de valoriser davantage les aciers à haute limite élastique dans la construction des poutres à âme pleine.

Cependant, nous ne croyons pas qu'il soit ni intéressant ni prudent de descendre en dessous de la valeur $s = 1$ pour les constructions en acier A. 37.

B) Résultats concernant le dimensionnement des raidisseurs

En ce qui concerne le dimensionnement des raidisseurs, les résultats obtenus par M. ROCKEY sont en quelque sorte complémentaires des nôtres, parce qu'il étudie le comportement des raidisseurs verticaux, tandis que nous avons à peu près exclusivement porté notre attention sur les raidisseurs horizontaux.

Néanmoins, les valeurs expérimentales que nous avons obtenues pour la rigidité relative optimum γ ⁽³⁾ sont nettement supérieures à celles obtenues par M. ROCKEY. Cette différence considérable provient, à notre avis, de trois causes bien distinctes :

- a) nous avons imposé à nos raidisseurs l'obligation de rester rectilignes jusqu'à la ruine de la poutre, ce qui semble plus sévère que la condition imposée par M. ROCKEY et, en général, par les ingénieurs britanniques, concernant le rôle que doivent jouer les raidisseurs dans le stade de ruine.

⁽³⁾ γ est le γ_1 de M. Rockey et la «Mindeststeifigkeit» des auteurs allemands.

- b) les valeurs théoriques de γ sont déterminés dans l'hypothèse d'une plaque appuyée sur ses quatre bords; les conditions d'appui réelles étaient nettement plus proches de l'encastrement parfait dans les essais britanniques que dans les nôtres, ce qui peut avoir pour effet de diminuer la valeur de γ .
- c) enfin, les raidisseurs expérimentés étaient de formes très différentes (cornières rivées avec une aile parallèle à l'âme chez M. ROCKEY; plats soudés normaux à l'âme chez nous). Le type de raidisseur employé par M. ROCKEY n'est peut-être pas très économique, parce qu'il a un faible rayon d'inertie, mais il réalise un certain encastrement de l'âme sur ses bords verticaux et possède une stabilité propre supérieure à celle d'un plat saillant de faible épaisseur.

Vu la discussion qui précède, il paraît dangereux de transposer à l'acier, sans examen approfondi, les valeurs de γ obtenues sur l'alliage d'aluminium.

R É S U M É

Les résultats obtenus sur des poutres à âme mince en alliage d'aluminium ne peuvent pas être appliqués sans précautions à des poutres en acier doux, parce que le rapport R_e/E est beaucoup plus grand dans le cas de l'alliage d'aluminium. Il serait raisonnable d'adopter des coefficients de sécurité au voilement différents pour des matériaux différents. Ces coefficients devraient être d'autant plus faibles que R_e/E est plus grand.

Par ailleurs, il importe, pour obtenir une charge de ruine de la poutre aussi grande que possible, de donner à la semelle comprimée une grande stabilité propre, ce qui conduit à des poutres à semelles tubulaires type Dörnen.

S U M M A R Y

Ratio R_e/E being much greater for light alloys, the results obtained from tests on thin webplate, light alloy girders, cannot be extended without further caution to mild steel girders. It would seem reasonable to admit different buckling safety factors for different metals. The greater the ratio R_e/E , the smaller the safety factor should be.

To increase the girder's collapse load, the flange submitted to compression should have a good self-stability; this leads to tubular flanged girders of the Dörnen type.

ZUSAMMENFASSUNG

Die Resultate, die man für Träger mit dünnem Steg aus Aluminium erhält, dürfen nicht ohne weiteres auf Träger aus normalem Flussstahl angewendet werden, weil das Verhältnis R_e/E für die Aluminiumlegierung viel grösser ist. Es wäre vernünftig gegen das Beulen verschiedener Materialien, verschiedene Sicherheitskoeffizienten einzuführen. Diese Koeffizienten sollen umso kleiner sein, je grösser R_e/E ist.

Anderseits ist es wichtig, um für den Balken eine möglichst grosse Bruchlast zu erhalten, dem Druckflansch eine grosse Eigenstabilität zu geben, was zu Balken mit röhrenartigen Flanschen, Typ Dörnen, führt.

RESUMO

Os resultados obtidos com vigas de alma delgada de ligas de alumínio, não se podem aplicar, sem precaução, a vigas de aço macio, visto a relação R_e/E ser muito maior no caso das referidas ligas. Parece razoável adoptar factores distintos de segurança à encurvatura para materiais diferentes. Esses factores devem ser menores, quanto maior for a relação R_e/E .

Por outro lado, para aumentar a carga de rotura de uma viga, convém aumentar a estabilidade própria do banzo comprimido o que conduz a vigas de banzo tubular, do tipo Dörnen.

IV 5

The design of the webplates of light alloy plate girders

Reply to the discussion

Die Berechnung der Stehbleche von Leichtmetallträgern

Antwort auf die Diskussion

Cálculo das almas das vigas de ligas leves

Resposta à discussão

Calcul des âmes des poutres en alliages légers

Réponse à la discussion

K. C. ROCKEY

Swansea

Dr. Rockey thanks Professor Massonnet for his kind remarks and for presenting his valuable communication.

The author is particularly glad that Professor Massonnet has pointed out that providing all other things are equal, a smaller factor of safety with respect to web buckling should be used with high strength aluminium alloy girders than with steel girders, because of the greater reserve of strength in the post-buckled range which is obtained with the former. It was in order to utilise more fully this reserve in the load carrying capacity of the webs of light alloy girders, that the authors recommended that the webplates should be designed to operate in the post-buckled range. When loaded beyond its buckling load, a webplate develops a wavy surface and it is possible that with certain designs, objections, based on aesthetic considerations would be made with respect to the appearance of this wavy surface before the maximum stress in the webplate had reached the maximum permissible stress. In other words, when designing members to operate in the postbuckled range, both aesthetic and strength requirements have to be considered and it is possible that conditions will arise when the former requirement is the controlling one.

The author assures Professor Massonnet that it was not his intention to convey the impression that the effects of web buckling can be disregarded. In fact, the decision to allow webplates to operate in the post-

-buckled range means that it is necessary to understand more fully the effects of web buckling upon the behaviour of the flange members and the stiffeners.

In this connection, one problem which has hitherto not received a great deal of attention is that of the influence of flange rigidity upon the post-buckled behaviour of the webplate. At the present time, many girders are being designed with flanges which have a low flexural rigidity about an axis (xx) perpendicular to the webplate, see Fig. 1. These flange members are not capable of effectively carrying the lateral loads which are imposed upon them by the slightly buckled webplate. The author

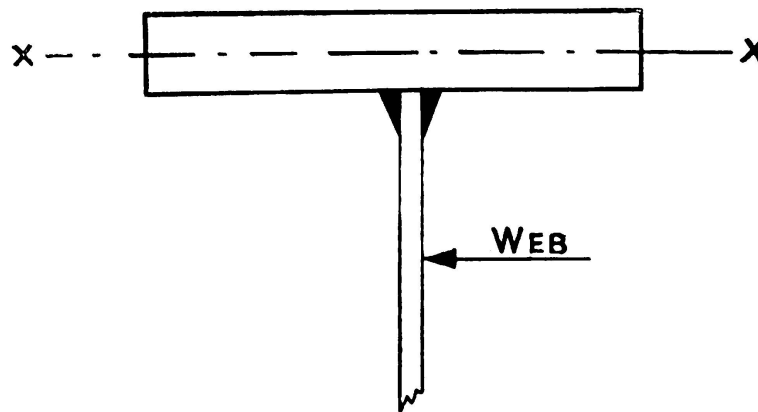

FIG. 1

was therefore very interested to learn that Professor Massonnet has found that by the use of effective horizontal stiffeners he has been able to increase the failing load of such flange members. The author agrees with Professor Massonnet that it is necessary to use flanges which have a greater flexural rigidity about the xx axis. The experimental work which Professor Massonnet is going to conduct on girders of the Doren type, see his figure 2b, will therefore be a most valuable contribution, and the results of this work will be awaited with interest.

The problem of designing the flange-stiffener combination of plate girders so that an efficient structure is obtained has been studied by the author and his research team at Swansea. The author first became aware of the need of such an investigation some years ago while testing welded steel girders [1]. It was noted that if the flanges possessed a low flexural rigidity about their xx axis, see Fig. 1, they deflected considerably once the buckling load of the panel was exceeded. Since then some 30 girders have been tested to determine the effects of flange rigidity upon the post-buckled behaviour of webplates subjected to shear and to a combination of shear and bending. From this work, curves have been obtained which provide values of the lateral deflection of the webplate in terms of the effective flexural rigidity of the flanges and the ratio applied load W /buckling load W_{cr} .

This work [2], as yet unpublished in full, has shown that if the flange flexibility of the flanges as represented by the parameter I/b^3t , where

- I = flexural rigidity of the flanges about an axis xx through their centroid, see Fig. 1;
- b = Spacing of vertical stiffeners;
- t = Thickness of webplate;

is reduced below a given value the webplate will develop excessively large deflections and it is recommended that girders should be designed so that the value of the parameter I/b^3t shall not fall below the values given in equation 1.

$$\frac{I}{b^3t} = 0.00035 \left[\frac{W}{W_{cr}} - 1 \right] \quad (1)$$

(but not less than 0.00035).

With respect to the design of intermediate vertical stiffeners, the empirical relationships between the size and spacing of vertical stiffeners and the buckling stress of the webplate which are given in the author's paper, see equations 1 to 5, were obtained from elastic tests and these relationships can therefore be used for either steel or aluminium construction. The value γ_L will ensure that the stiffeners are straight when the webplate buckles. From the tests on aluminium girders, it has been found that providing flange failure is prevented, little gain in ultimate strength is obtained by employing stiffeners having a flexural rigidity greater than EI_L . However, the author would agree that if the requirement that the stiffener is to remain straight up to failure, as laid down by Professor Massonnet, is to be achieved, then it would be necessary to employ stiffeners having a flexural rigidity greater than EI_L .

Professor Massonnet has referred to the difference in requirements with respect to post-buckled behaviour of stiffener webplates made by various authorities. The requirements he imposes are more severe than those required in the United Kingdom and he will no doubt be interested to learn that in the United Kingdom it is proposed [3] to permit the use of slightly buckled webs in steel plate girders.

Professor Massonnet has referred to the fact that the first series of tests conducted at Swansea have dealt with webplates stiffened only by vertical stiffeners, whereas he has concentrated more on the behaviour of horizontal stiffeners. Since preparing his paper, the author has commenced investigations to examine the behaviour of webplates stiffened by both horizontal and vertical stiffeners. This work is well advanced, and it is hoped that it will enable a design procedure, utilising both horizontal and vertical stiffeners, to be developed for aluminium girders.

REFERENCES

1. K. C. ROCKEY — *Stability problems associated with the design of plate girder webs.* (Civ. Eng., London, vol. 47, p. 821 (Oct. 1952); p. 918 (Nov. 1952), vol. 48, p. 66 (Jan. 1953).
2. Discussion of Structural papers Nos. 48 and 49. Proceedings of the Institution of Civil Engineers, part III, vol. 5, August 1956, No. 2, p. 490-493.
3. Draft Copy B. S. 153 — *Girder Bridges.*

SUMMARY

The significance of plate buckling is discussed and the factors affecting the choice of design stresses are examined. Attention is drawn to the influence of flange rigidity upon the post-buckled behaviour of webplates subjected to shear, and an empirical rule is presented which recommends the minimum flexural rigidity which flanges should possess. The influence of the rigidity of vertical stiffeners upon the ultimate strength of webplates is also discussed.

ZUSAMMENFASSUNG

Die Bedeutung des Beulens von Platten wird diskutiert und die Faktoren, welche die Wahl der zulässigen Spannungen bestimmen, werden untersucht. Die Aufmerksamkeit wird auf den Einfluss der Flanschsteifigkeit auf das Verhalten der ausgebeulten, Schubbeanspruchung unterworfenen Stehbleche gelenkt, und es wird eine empirische Regel zur Bestimmung der minimal erforderlichen Biegesteifigkeit der Flanschen angegeben. Der Einfluss der Steifigkeit der vertikalen Aussteifungen auf den Bruchwiderstand der Stehbleche wird ebenfalls diskutiert.

RESUMO

O autor discute o significado da encurvadura de uma placa e examina os factores que influem na escolha das tensões admissíveis. Chama a atenção para a influência da rigidez dos banzos sobre o comportamento das almas submetidas ao corte, depois de encurvadas e indica uma fórmula empírica que permite determinar o valor mínimo da rigidez de flexão dos referidos banzos. O autor também discute a influência da rigidez dos reforços verticais sobre a carga de rotura das almas das vigas.

RÉSUMÉ

L'auteur discute la signification du voilement des plaques et examine les facteurs qui affectent le choix des contraintes admissibles. Il attire l'attention sur l'influence de la rigidité des semelles sur le comportement des âmes soumises à l'effort tranchant après voilement et présente une formule empirique donnant la rigidité à la flexion minimum que doivent avoir ces semelles. Il discute encore de l'influence des raidisseurs verticaux sur la charge de rupture des âmes.