

IIIc. Various welding methods for the execution of welded steel construction

Objektyp: **Group**

Zeitschrift: **IABSE congress report = Rapport du congrès AIPC = IVBH
Kongressbericht**

Band (Jahr): **5 (1956)**

PDF erstellt am: **08.08.2024**

Nutzungsbedingungen

Die ETH-Bibliothek ist Anbieterin der digitalisierten Zeitschriften. Sie besitzt keine Urheberrechte an den Inhalten der Zeitschriften. Die Rechte liegen in der Regel bei den Herausgebern.

Die auf der Plattform e-periodica veröffentlichten Dokumente stehen für nicht-kommerzielle Zwecke in Lehre und Forschung sowie für die private Nutzung frei zur Verfügung. Einzelne Dateien oder Ausdrucke aus diesem Angebot können zusammen mit diesen Nutzungsbedingungen und den korrekten Herkunftsbezeichnungen weitergegeben werden.

Das Veröffentlichen von Bildern in Print- und Online-Publikationen ist nur mit vorheriger Genehmigung der Rechteinhaber erlaubt. Die systematische Speicherung von Teilen des elektronischen Angebots auf anderen Servern bedarf ebenfalls des schriftlichen Einverständnisses der Rechteinhaber.

Haftungsausschluss

Alle Angaben erfolgen ohne Gewähr für Vollständigkeit oder Richtigkeit. Es wird keine Haftung übernommen für Schäden durch die Verwendung von Informationen aus diesem Online-Angebot oder durch das Fehlen von Informationen. Dies gilt auch für Inhalte Dritter, die über dieses Angebot zugänglich sind.

IIIc1

Some aspects of the fabrication of welded structures

Einige Betrachtungen zur Herstellung geschweisster Bauwerke

Alguns aspectos da execução das estruturas soldadas

Quelques aspects de la construction des charpents soudées

J. D. THOMPSON

D. C. C. DIXON

The Cleveland Bridge & Engineering Co. Ltd.

Darlington

I. Introduction and scope of paper.

The paper will examine part of the present field of knowledge in workshops (and erection technique as it affects the shop) in order to show in what direction development may most profitably be directed. It will also indicate some of the lines along which development is already proceeding. Particular reference will be made to the superiority of automatic and semi-automatic welding and it will be shown that, given adequate organisation and supervision, methods of using machines can be devised to suit the small number off which form the main bulk of jobbing work.

The paper is intended only to deal with the normal run of jobbing work in a structural works handling a very wide variety of welded construction. It will not refer to weldments involving welding to Lloyd's Class 1 Standard, nor deal with work involving very large numbers of repetition items, since automatic set-up can almost invariably be adopted where the number-off justifies it. It is not proposed to discuss on what structures the use of welding is technically sound.

Owing to the requirements of the Association to achieve brevity, many important aspects have had to be omitted from the Paper as originally written.

II. *Discussions on design and cost.*

Most of those Engineers who are or have been engaged in the fabrication of welded structural steelwork started with many preconceived ideas based on experience in the fabrication of rivetted steelwork. The remainder, since welding is a comparatively new technique, started with no experience at all. Development has therefore frequently been hindered by prejudice on the one hand and ignorance on the other. Only now is it becoming possible to obtain a general and balanced view of the advantages and disadvantages, the possibilities and the limitations of welding in structures.

Economies in weight of steelwork can be made in almost all structures if they are welded instead of rivetted. For individual members the main savings are as follows:—

Plate Girders 16 %
Box Girders and Box Columns 15 %

In many cases, particularly where site welding is employed, not only these savings may be achieved but also others due to the further degrees of redundancy which may easily be incorporated into the design of complete structures. This applies to a greater degree where frames are designed by the plastic theory and not by the elastic. For portal frames with a span of 50 feet and a constant roof slope of $\tan^{-1} 1/2$ the percentage savings over an elastically designed portal can be as much as 27 %.

There is, therefore, no question that economies in weight can be made by the use of welding in structural steelwork. It is frequently asked however, whether this saving in weight is not offset by the increased cost per ton of fabrication and erection. There is an assumption implicit in this question that the cost per ton of welded steelwork is greater than that for rivetted. It is one of the purposes of this paper to demonstrate that for specified steelwork details, fabricated by specified methods, welding can and does produce a cheaper rate per ton. A rate per ton is made up of the cost of materials, the labour content, the overheads (generally expressed as a percentage of the labour content), and the profit (expressed as a percentage of the whole). For a fixed cost of materials the labour content therefore establishes the rate per ton. Since box and H Sections form the majority of members used in the design of structures it is in the labour content required in their fabrication that the greatest interest arises. For welded steelwork there is an additional charge due to the cost of electrodes but to counterbalance it there is a saving in overheads due to the speed with which welded steelwork may pass through the shops. This is due to drilling and rivetting being replaced by the single process of welding. For the figures given below the best techniques of fabrication for rivetted work developed over the last century were used, and, in the case of the welded members the suggested methods outlined in the succeeding sections of this paper. In Figs. 1, 2, 3, 4 are shown sections of girders which have commonly had to be fabricated over the past few years, both by welding and

rivetting. The figures include for the fabrication of end connections and for the facing of the ends of a proportion of the members. All figures given are in man hours per ton (2,240 lbs.).

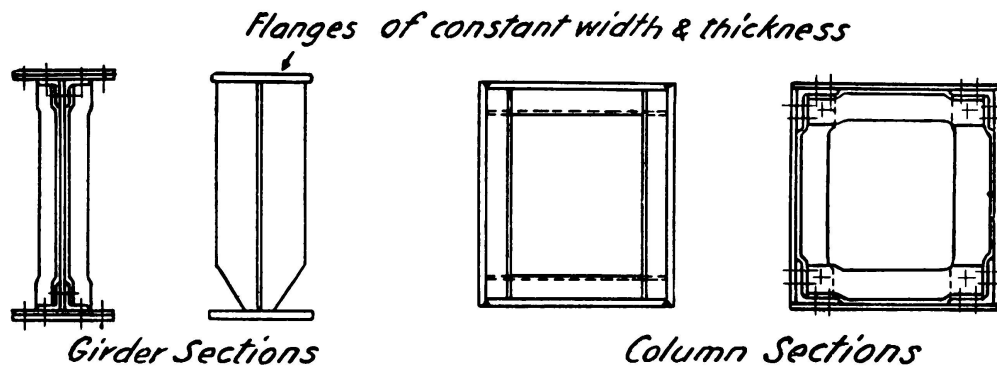

FIGS. 1, 2, 3 e 4

| | Total | Plane or Gas Cut (?) | Mark & Drill | Plating | Rivet & Chip | Weld | Other (1) |
|---|-------|----------------------|--------------|---------|--------------|------|-----------|
| 1 | 47.89 | 1.47 | 8.45 | 9.09 | 4.09 | — | 24.79 |
| 2 | 40.42 | .88 | 1.09 | 6.96 | 1.62 | 9.61 | 20.26 |
| 3 | 50.18 | 2.43 | 3.67 | 6.06 | 1.12 | 9.46 | 27.44 |
| 4 | 50.60 | 1.98 | 9.11 | 10.55 | 5.97 | .49 | 22.5 |

NOTES:

(1) «Other» includes all other trades not otherwise detailed, also labour in handling, crane drivers, etc.

(2) «Plane» and «Gas Cut» are shown under the same heading as either process may be used for welding.

There is a considerable difference in the prices quoted for the erection of welded steelwork, whether the connections are rivetted, bolted or welded. Site rivetting is invariably more expensive than site bolting due to the time necessary where connections are above ground level in scaffolding, fixing cover plates and in landing the piece and bolting up the cover plates. Figs. 5 & 6 show a rivetted connection between rivetted box stanchions and a bolted connection between welded box stanchions. The comparative man hours were 54 for the rivetted connection against 12 for the bolted connection.

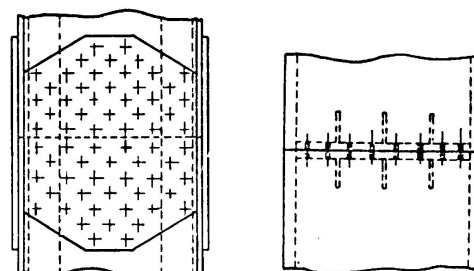

FIGS. 5 e 6

Where site connections are welded, the prices quoted for the erection of similar buildings vary greatly. This largely arises from the fact that there are neither standard details nor methods of making the connections and laying the welds. Even where the extra degrees of redundancy due to rigid all welded construction at site result in savings in weight, and where the individual pieces fabricated in the shops are the largest practicable, it is still rarely as yet that economy is shown over site bolting.

III. *Methods of fabrication.*

Factors determining future development.

Existing knowledge suggests certain premises on which the future development of methods of fabrication should lie.

- (i) Appendix A shows an analysis by operations of the man hours required for various types of welded fabrication. The relative proportion of the figures rather than the figures themselves is important. The following deductions may be drawn —
 - (a) The figure for «labour» is for all trades not under the other headings and includes for all handling, crane drivers etc. and is invariably between 20 % and 25 % of the total. A saving in any other figure will therefore probably involve a saving also under this heading.
 - (b) 15-20 % only of the man hours required is needed for the actual process of welding. Of these perhaps half are required for tack welding which in the U. K. is generally performed by the welder. In the case of the lower figures the welding was performed by an automatic machine which demonstrates the savings made by means of this machine.
 - (c) The largest figure is for platers and their helpers. Since a tack welder must be present during a part of the assembly period it is clear that this heading offers the greatest scope for economies.
- (ii) Box and H Sections are those most commonly fabricated. They have in common —
 - (a) That both are long in comparison with their cross section
 - (b) That both can be welded using automatic machines
 - (c) Their number suggests line production methods should be employed.
- (iii) The development of Universal manipulators and speedy methods of assembly indicate that weldments within the capacity of of manipulators can be fabricated cheaply, especially where repetition can be achieved.

- (iv) Essential to the efficient development of welded work are a shop layout where the stockyard and preparation bays can feed any of the assembly bays with equal facility and that the preparation of materials is of the highest accuracy since accurate preparation is the key to good quality welded work.

Plating and Assembly.

It was indicated in the previous section that the greatest scope for economy in man hours was in the process of plating and assembly.

Since it is generally desirable at present to drill such holes as may be required after welding because of the difficulty of estimating accurately any shrinkage that may occur, the handling and positioning of plates is made more difficult because, for example, shackles cannot be fixed nor can drifts be employed. Further, some force may be required to achieve the good fit up frequently essential for machine welding. These problems are common to almost all weldments whether they are assembled on the floor or in a rig. There are three methods of surmounting them which are worthy of mention.

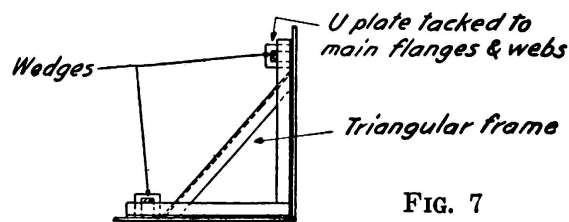

FIG. 7

- (i) Temporary studs may be affixed using a stud welder. They are subsequently chipped off and the plate ground flat. Studs are also extremely useful for light connections such as those required for wall ties or handrailing, and where the alternative detail may be to drill, insert the bolt and tack weld on the inside. The advantage is emphasised where enclosed sections such as box columns are concerned. A development of the principle

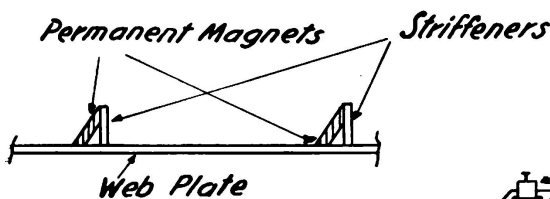

FIG. 8

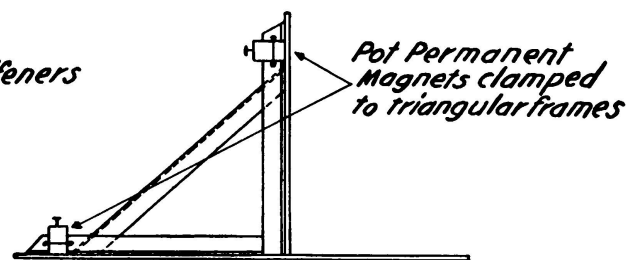

FIG. 9

of using studs for assembly purposes is shown in Fig. 7 which illustrates a method of facilitating the assembly of the side plates of a box girder.

- (ii) Permanent magnets are available in several sizes and shapes which have great power in relation to their weight. Examples of their use are shown in Figures 8 and 9.

Figure 8 shows the positioning of stiffeners on the web of (say) an H girder where the main fillet welds are to be laid by hand. The plater can advance down the length of a long web placing the stiffeners at a high rate and the welder can follow behind with no waste of time due to waiting.

Figure 9 shows a diaphragm of a box girder positioned vertically before the side plates are assembled, the diaphragm thus acts as an aid to this process. The magnets shown in Figure 9 are $4\frac{1}{2}$ " cube and exert a pull of 450 lbs. with an air gap of .005".

(iii) Toggles have two outstanding qualities in the assembly of welded steelwork —

- (a) they exert a considerable force over a short distance
- (b) if the lever is taken so far that the mechanism just passes «dead centre», then steel being clamped will be locked in position.

Despite the most careful rolling, plates, especially when large, are not always so flat that when plated the fit up is good enough for welding. Figures 10 and 11 show toggles being used to perfect the fit up on box

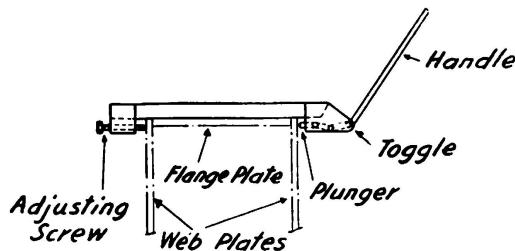

FIG. 10

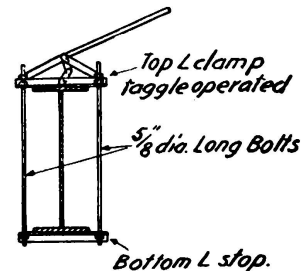

FIG. 11

girders and plate girders. In both cases the mechanisms are slid along the girders in steps of approximately two feet and as the mechanism locks, a welder places a small tack. Each step therefore only occupies a few seconds.

Manipulation.

There are three primary reasons why manipulation of weldments is advisable.

- (1) Automatic welding can only be carried out in the downhand and horizontal/vertical positions and with a little further trouble in the horizontal position
- (2) Downhand welding is cheaper to effect and, as recent research has shown, gives a better quality weld than those laid in any other position with the exception of vertical.

- (3) Even with the simplified details possible with welded steelwork there are inevitably a considerable number of fittings that must be placed on girders and stanchions subsequent to the main assembly. These are naturally easier to position on a horizontal surface than one which is sloping, vertical or overhead.

For weldments requiring rotation about two or these axes, the economical shape is that which has approximately equal dimensions in each plane. Should the weldment have dimensions in one or two planes greatly exceeding the other then the size of manipulator required will be uneconomic and easily movable stagings will be required off which the operators may work.

For weldments requiring rotation about one axis only, the economic shape is that which has one large dimension and is small in the other two. A second large dimension will either demand a pit or the elevation above shop floor level of the manipulators.

All other things being equal it is therefore good practice in the shops to split fabrications into sub-assemblies conforming to one of these two classes prior to the final assembly of welding them together.

An example is in the assembly of box girders. It is a matter of opinion whether it is quicker to assemble on a gantry or in a manipulator, but there is no doubt about its use for operations required after the main seams are welded. The processes then necessary are —

- (i) On each of three faces mark the centre line and both ends for facing.
- (ii) On all four sides mark the cleat positions, place the cleats and tack weld them.
- (iii) Make a rough check of the cleat positions by a chargehand plater or a templatemaker against any gross errors.
- (iv) Fully weld the cleats on four sides.
- (v) Make a final and accurate check of all marking and of the cleat positions.

These operations require men of several trades to perform operations which cannot be carried out concurrently. A minimum of eleven turns are required for each box.

There is room for improvement in the normal methods of marking such a girder, mechanical or optical methods present difficulties which have not to the authors' knowledge yet been overcome.

Employment of Automatic Welding Machines.

There appear to be widely differing opinions as to whether an assembled and tack-welded fabrication should be taken to a rig incorporating an automatic welding machine or whether the automatic welding machine should be taken to the fabrication. Figure 12 shows a rig which includes two automatic welding heads and is suitable for either H or

box sections. The welding heads can travel both longitudinally and laterally.

Two automatic welding machines can be employed to lay two fillet welds on an H girder simultaneously. The machines are mounted on straight channels thus proceeding in a straight line.

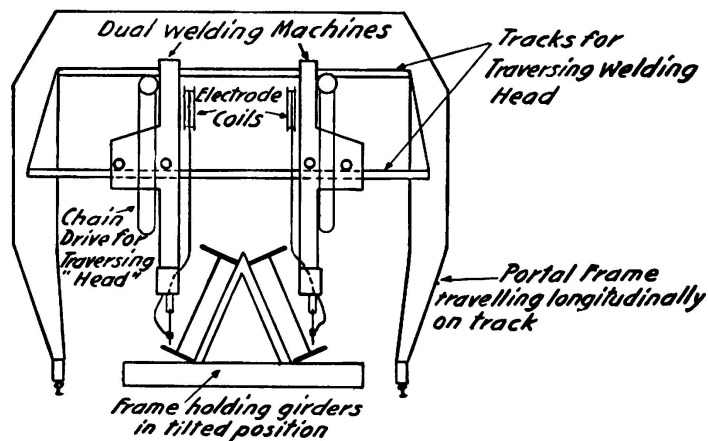

FIG. 12

The latter course is initially cheaper, appears more economic than the former, and certainly provides more flexibility in the shops.

The use of automatic machines has so far only been considered in relation to the main welds on long sections. It is shown in the next section that it is economic to use automatic methods for other and shorter runs. For this purpose where the fabrication is easily moved and mani-

pulated, it may well be advisable to have machines mounted on permanent rigs so that the machine may move over the work. Where the fabrication is too large for easy handling an easily portable set as described in the next section, will probably be advantageous.

Rate of Throughput.

For those who wish to increase their output by adding to their floor area, there is a saying in England that they should instead increase their speed of throughput. Welded steelwork both in its design and fabrication lends itself to such an increase. There seems, for example, to be no reason why H girders, unless of considerable size, should ever take more than 36 working hours to pass through the assembly and welding bays.

Importance of Production Control.

The authors have made some study of the weldmetal operators lay per hour in various works and in various countries. They have come to the conclusion that where the work is laid out ready for the welder so that there is no external cause of delay, very much the same amount will be laid per hour by willing workers in almost all cases. It therefore seems that the figures obtained vary with the efficiency of the management concerned in organising the work. The problem is aggravated for the management by the fact that if a weld is long then it will pay to use an automatic machine welder and the production welding by the hand operator will therefore be in shortlengths. These lengths will become the shorter as the techniques of setting-up and running automatic machines are advanced. Moreover the cleats and fittings for major fabrication will

be many and largely similar, and to keep a suitable supply for all engaged on assembly, will be difficult. It has been shown that men of several trades will be required successively (and often more than once) for operations on the same fabrication. It is therefore emphasised that techniques are of little value if the Progress and Production Control Departments are not extremely efficient.

IV. *Welding processes.*

The development of arc welding from the early days of bare wire electrodes, has resulted in three main methods of welding in use at the present time, namely, hand welding with shielded arc electrodes, semi-automatic welding using either submerged arc or shielded arc, and fully-automatic machine welding, sub-divided into the same two categories.

In this paper it is not proposed to deal with gas shielded arcs, a process which is as yet not fully developed, and at the present time is prohibitive in cost, due to the use of Argon gas, nor with the self-adjusting arc process, which similarly is not yet sufficiently developed for practical use.

There seems little doubt that in the majority of fabricating works, in this country at any rate, hand welding is the basic method. It is the author's opinion however that the correct line of development is the increasing use of automatic or semi-automatic methods for ever smaller runs of weld, and that machines must be produced which are easily portable, so that the machine can be taken to the job rather than the job to the machine. This is in most cases current practice, due to the great weight and mass of equipment which characterises automatic machines.

The introduction of high tensile steel, and the difficulties encountered in welding low alloy steels, have led to the development of the low hydrogen or lime-ferritic coated electrode, with the aim of overcoming cracking in the heat affected zone immediately alongside the laid weld. Recent research however tends towards the view that such cracking is the result of too rapid cooling in the critical heat range (400° F to 200° F) and that control over the cooling rate rather than the use of special electrodes is the answer to the problem. At least one major bridge in high tensile steel is being welded with ordinary rutile coated electrodes, with close control over the arc energy input. It is intended that such heat should be introduced that the cooling rate through the critical zone is slowed down sufficiently to give freedom from cracking. There seems however little doubt that under normal welding conditions, the low hydrogen electrode does give the better weld and greater freedom from cracking, where pre-heating or other forms of cooling control are not employed.

In the authors' opinion the use of automatic welding confers advantages which far outweigh the additional cost of initial purchase of equipment. With automatic methods there is considerable freedom from dependence on operator skill, and provided that suitable methods of supervision are employed, the weld as laid can almost be guaranteed in quality. The

chief disadvantage of automatic welding has hitherto been the immobility of the equipment. Massive transformers and heavy cables have largely restricted the use of automatic welding to long runs on standardised productions, and many works, rightly or wrongly, consider that the expense of rigging up with automatics on a number of «one off» jobs is unjustified. The authors believe that the quality of automatic work is such that even where economic gain is negligible, its employment is desirable, and they have therefore specified its use whenever possible. Automatic fillet and butt welding is consequently now standard practice on almost all classes of work. Although considerable experiment has already taken place, it has not yet been found possible to fillet weld satisfactorily with open arc automatics. Fillet welding by submerged arc is carried out normally on production line work, using either one machine or two machines simultaneously on both sides of girders.

To overcome the disadvantage of lack of mobility with both open and submerged arc fully automatic machines, the authors have developed a semi-automatic machine, on lines which they believe to be quite original. The makers supply a generator and a relay for feeding coiled electrode wire, (both these items are portable) and an electrode holder consisting of a cone-shaped canister for holding flux powder through which the electrode wire is automatically fed as soon as contact is made. The outfit is intended for the laying of submerged arc weld by manual operation. By attaching this holder to a well-known make of «straight-line» oxy-cutting machine, the electrode holder taking the place of the cutting head, an automatic machine is obtained which is completely portable (the welding end, i. e. the part to be handled by the operator, weighs only 28 lb. when full of flux powder and ready to work). By the use of this machine it has been found economic to machine weld runs as short as 3-ft. The whole apparatus is readily transferred from shop to shop, and is not much more difficult to move about than the average rivetting hammer.

Experiments with submerged arc automatic welding in a horizontal position are being undertaken as time permits in the authors' works. At the present time they have not reached a point where any final conclusions may be drawn. Successful welds have been laid in this position using single and double arcs, but to date it has not been found possible to guarantee the shape of the finished bead, many of which exhibit a «pear» shape. Penetration has been good, and if means can be found to control the shape of the bead, this method will be introduced generally, thereby eliminating a considerable amount of handling of large pieces in the shop.

The authors believe that future development along the lines just mentioned, will show increasing reduction in cost consistent with quality of finished work.

V. *Materials.*

The scope of this paper does not include the welding of special steels such as high carbon or high alloy steels, which require special techniques. In ordinary construction work steels to B. S. S. 15 for mild

steel and B. S. S. 968 for high tensile steel are normally encountered. New types of steel for use when designing for tension stresses of some magnitude (e. g. N. D. 1 and N. D. 2 steels) are now coming into production in England. These steels have had to be introduced due to the demand for greater notch ductility, which ordinary mill steels are unable to guarantee. Steels to similar specifications are being rolled on the Continent, but suffer also from the disadvantages mentioned in the next paragraph.

The general requirements for a weldable steel are a high degree of notch ductility, freedom from undesirable quantities of impurities likely to gas absorption during welding, or formation of manganese or iron sulphides, and a consistently high quality of rolling. More and more Authorities are to-day calling for notch ductility tests, either Izod or Charpy, or both, on steels over certain specified thickness, or where such steel is subject to tension. Since there is no physical quantity by which the notch ductility of a steel may be measured, nor any mathematical relation between values obtained from impact tests and notch ductility, Impact Test values can only be a guide to notch ductility and are therefore arbitrary and widely varying. It is essential therefore that the present programme of research should be intensified in order to produce a satisfactory answer to this problem. A specification must be quickly found that will not only remove doubts as to the reliability of welded steelwork, but also relieve the Steelwork fabricator of the many stringent tests now required, which do not achieve their object.

VI. Problems arising from use of welding.

(1) Fatigue.

Despite a great deal of research, there is at present no knowledge of the actual mechanism of failure due to fatigue. The extent of this is illustrated by the fact that should a bar be subjected to a certain set of alternating stresses, the number of reversals before failure can only be predicted to the extent that the lower number is a ninth of the upper. It is only known that certain features of design and specification are likely to accelerate failure. Regions of relatively high stress due to the change of form due to design requirements are the most common example of such a feature. Shafts, for instance, sharply shouldered, practically always fail at the shoulder, and it has been proved that increased life can be obtained by grooving immediately behind the shoulder.

The same method is used by manufacturers of rivet snaps to relieve the sharp diversion of lines of stress which occur at the neck of the snap.

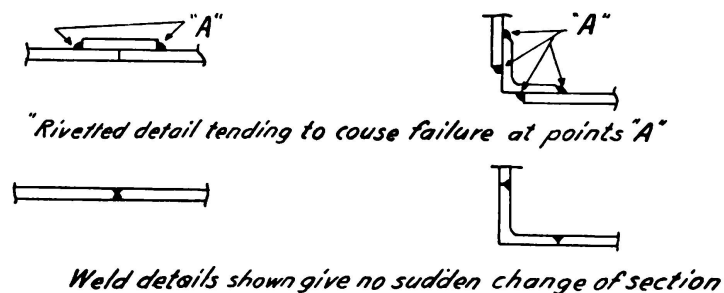

FIG. 13

Similar sudden alterations of section in structural work have similar effects, and designers brought up in the rivetted school who apply «rivetted» details to welded work, fall frequently into this fault. Examples are shown in Figure 13.

(2) *Distortion and contraction.*

One of the greatest disadvantages of welded work as against rivetted work is the difficulty of maintaining correct shape and line, and of keeping key dimensions true. It is generally true to say of rivetted construction that as long as a girder is allowed to cool out true it will retain that shape irrespective of what is later done to it. With welding, the concentrations of heat are such that serious distortion can and does take place, and, unless considerable care is exercised, the finished article may well be so distorted as to be unusable in its completed structure without extensive correction and straightening.

The first essential for distortion-free work is careful preparation, and accurate fitting of component parts while they are being assembled and tacked. If a girder or a box is tacked together «in wind» it will very largely retain this «wind» whatever is later done to it. Jigs for assembly need not be elaborate, indeed the simpler the better, for production purposes. Furthermore, complicated jigs, in addition to taking time to fill, will tend to restrain, and it is the authors' belief that correct methods of fabrication are those in which the member is free to move all the time.

The second essential is that the heat input should be balanced in such a manner that distortion is minimised.

It has been established in practice that automatic welding causes much less distortion than hand welding, and that girders which have to have their flanges «pre-set» for hand techniques, require no such operation for automatic work (Figure 14). Small amounts of distortion, as the $1/64$ " quoted, being ignored.

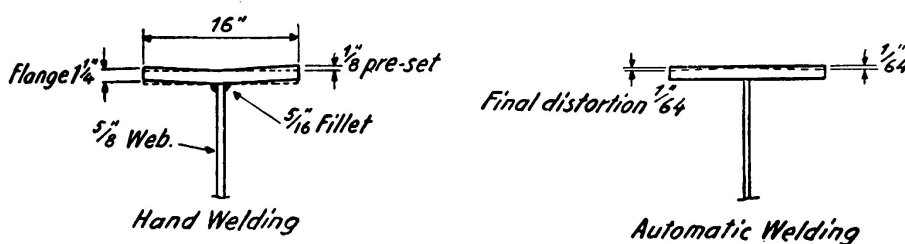

FIG. 14

In certain cases, distortion of flanges may be overcome by the use of «strong-backs» (Figure 15) or by the method of setting quick release toggle jacks between flanges while welding is in progress (Figure 16).

Contraction in length is another serious problem to be faced. In the authors' Works, attempt is being made to set out a contraction chart,

taking account of the various factors which affect it, the most important of which are —

- (1) Sequence of welding
- (2) Number of stiffeners and/or diaphragms
- (3) Method of welding (hand or automatic).

The amount of contraction, although it can seldom be exactly forecast, can by long experience be sufficiently accurately predicted as to enable the fabricator to hole webs, flanges, stiffeners etc. before welding. For instance, in a girder which is auto-welded webs to flanges first, and subsequently stiffened, contraction would be in the region of $1/32''$ per $10'0''$. For a girder stiffened and then flange welded by hand, corres-

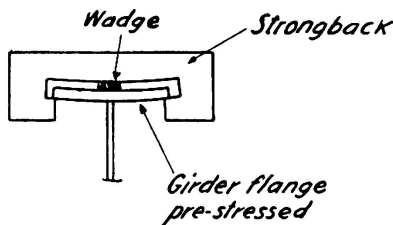

FIG. 15

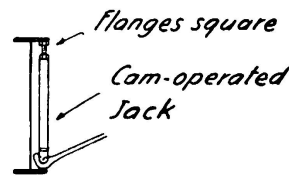

FIG. 16

ponding contraction could amount to $5/32''$ per $10'0''$. The gap allowed when butt welding flange or web plates should always be ignored when calculating the final welded length of plate.

In general, it may be laid down as a guide that weldments should be allowed to follow freely their tendency to distort or contract, and that due allowance for all these tendencies must be made when laying down the welding sequences to be followed and preparation methods to be used.

(3) *Residual stresses.*

There is any amount of evidence to show that whatever welding procedure is used, it is not possible to reduce the residual stresses below the yield point of the metal at local points adjacent to the welds. It seems reasonable to say that the object of good welding sequences is not so much to reduce the residual stresses but to reduce the demands made in fabrication on the ductility of the metal as it cools down. Evidence indicates that more serious effects are strain ageing and work hardening. It is recognised that microfissuring in weld metal is more prevalent than used to be the belief. There seems to be no doubt that with the presence of strain aged material, with fissures in the weld, and with the potential effect of the residual stresses, all the conditions exist for initiation of a fracture.

Following correspondence with certain Authorities as to the amount of residual stress caused by welding in stiffeners to girders which had previously been flange welded, it was decided to approach the British Welding Research Association with a view to carrying out a series of experiments. These experiments were carried out during the Summer of 1954, and would seem to indicate that the prior welding of flanges to webs, and subsequent stiffening, caused no more residual stress than the then more orthodox method of stiffening the web first and then welding the flanges in the normal «step back» way. From the results obtained it seems that in any case residual stresses were small compared with the normal superimposed load and that in some instances (notably tension flanges) residual compressive stress is of actual benefit in that it must be overcome before the flange is subject to tension.

Given satisfactory control over the actual operation of welding (and this means the minimum use of hand welding) and control over the sequence in which welds are laid, residual stress in most cases will not run disturbingly high, and it appears that a girder, restrained while welding, will generally carry higher residual stress than one in which free play has been allowed while welding and which had cooled straight and true when adequate precautions had been taken to obtain correct heat distribution.

The general effect of residual stress in girderwork is small unless the girder is subject to repeated loading, and until this condition occurs, residual stress has almost no effect on the ultimate strength of the structure.

The value of stress relief by heat treatment or other means is of doubtful value. Experiments have shown that little or no stress relief is obtained by shock or blows to a girder, nor do normalising furnaces seem likely to achieve the desired results, as in certain instances cracking of welds has been noticed after heat has been applied.

(4) *Porosity.*

The presence of holes in welded work has been a cause for disquiet among welding engineers for many years. The affinity of steel for hydrogen when it is heated above certain critical temperatures is well known, and it is this dissolved hydrogen which causes porosity when it segregates in cooling. The phenomenon is frequently met when butt welding flanges of excessive thickness by hand, and indeed it seems safe to say that flanges over 1½" in thickness almost always show some sign of porosity. It was assumed, at one time, and the opinion is still now held, that multitudinous runs of metal were the answer to porosity, one run refining the one previously laid, but actual experiment on butt welding of 2" thick flanges has shown that in laying 33 runs across a butt, and never allowing the area to cool off, hydrogen was present to such a degree that test specimens fractured after bending through 20°, revealing a mass of «fish eyes» at the fracture. To allow the hydrogen to escape, cooling must be much further retarded, and under actual shop conditions, by pre-heating the butts mentioned above,

highly satisfactory welds were made and test pieces were bent flat over on themselves without fracture. Subsequent sectioning through the weld revealed very few included bubbles of gas.

Porosity of a similar nature has long been a bugbear of automatic welding. In the authors' Works, accurate observations of porosity have been made over a period of years. The presence of moisture has little observed effect and good welds have made after a bucket of water has been emptied over the weldment under test. Mill scale when fresh seems to cause no blow-holing. The chief enemy of sound welds seems to be rust. Wire brushing is not sufficient to ensure rust removal, even when done by machine. Grinding is satisfactory when the steel is new. When, however, pitting is present, even in the slightest degree, the only completely satisfactory method is to sand-blast both surfaces to be welded. Observations made early in the authors' experience showed that patches of porosity often occurred immediately over tack welds. It was thought at the time that slag inclusions in the tack might have been the cause. Subsequent experiment proved however that slag was not the culprit. When tacks were freshly made no porosity resulted from auto. welding. When tacks were allowed to stand for a few days in damp atmosphere, the resultant rust developing almost invariably caused porosity.

Heat input per inch of weld laid has a considerable bearing on the presence of gas in the completed weld and the greater energy used normally when auto. welding would seem to give a finished weld of a more homogeneous nature, than that obtained by hand welding. Butt welding by automatic methods gives a comparatively hydrogen-free weld without pre-heating, while hand welding on a similar joint would almost certainly require pre-heat. The main disadvantage of the automatic process on short welds of this nature is high cost.

(5) *Pre-Heating.*

The use of pre-heat, on the normal run of welded work in a shop, is somewhat of a luxury, and the amount of benefit derived is questionable except in certain specified instances. Reference has already been made to the butt welding by hand of thick plates; the other instance is the welding of special steels. It is not within the scope of this paper to deal with special steels (high carbon, alloy and kindred types) but the welding of commercial «High Tensile» steels containing up to .25 carbon, is now becoming a fairly common proposition.

The British Welding Research Association has conducted fairly lengthy experiments in this direction and valuable data has been derived from them. The Controlled Thermal Severity Tests have made it plain within what limits hard zone cracking will take place with both rutile and the so-called «low hydrogen» electrodes, and in addition what energy must be used to obtain a heat input sufficient to overcome this tendency to cracking. Actual experiments on preheating to slow down cooling in the critical 400°/200° C range are now taking place with both hand and automatic welding procedures particularly when welding box members with flanges of considerable thickness in winter conditions in

England. It is hoped that these experiments will allow limits to be laid down for the minimum temperature, metal thickness etc. which will govern the use of pre-heating.

VII. *Inspection and testing.*

Where first class welding techniques are employed, a high proportion of the faults found are due to parent metal which is either imperfect or has a lack of homogeneity. The authors feel that far more attention should be paid to this matter.

VIII. *Labour problems.*

(1) *Operator Fatigue.*

One of the greatest advantages that automatic welding confers is the elimination of operator fatigue. Although it is true that recent developments in what may be termed «semi-automatic» machines have tended to reduce fatigue in operators, the fact remains that only when using fully automatic methods is the welder as reliable after 8 hours' working as he was when the shift began.

Operator fatigue resulting in inferior and faulty work can normally be minimised by

- (a) Easy positioning of work to avoid vertical and overhead welding (i. e. use of manipulators).
- (b) Use of electrodes which suit the individual (different operators give vastly different performances with the same electrode).
- (c) Good lighting of the work.
- (d) Good shop conditions, i. e. ample working space, good ventilation, provision of tackle which simplifies assembly and lifting.
- (e) The avoidance of excessive overtime working.

It is obvious that the elimination of operator fatigue is an important function of Management, both as an incentive to higher production as well as a guarantee of better-class work.

(2) *Fume Disposal.*

Point (d) above brings forward the question of fume disposal. This is a point which is often overlooked by Management, and is something which, in the authors' opinion, is responsible for a lot of the absenteeism because of which welding operators come in for so much criticism. The use of «smog masks» can do something to help, but by far the best thing is to remove the fumes before they can cause the damage. A main method of fume disposal is the use of exhaust fans, particularly where

men have work in confined spaces, especially where «low hydrogen» electrodes, giving excessive amounts of fumes, are employed.

Design of workshops, incorporating efficient systems of roof ventilation, can also play a large part in the health and efficiency of workers. The use of exhaust fans in the roof has not, in the authors' experience, been very successful, and it is recommended that natural draught be used as far as possible for this purpose. It is of interest that the movable «slat» type of ventilator which is capable of being opened to any desired degree, seems very successful in this connection.

(3) *Skill required in Operatives.*

Increasing use of fully automatic methods, the production of the «semi-automatic» machine, using either open or submerged arc and the use of «contact» electrodes, all combine to reduce the amount of skill required from operatives. In the case of fully automatic welding, once he is given the speed, current and flux powder grade, the operator is more or less reduced to a machine-minder, and skill has little or no result on the finished weld. Similar remarks apply to the semi-automatic machines, though not to such an extent, and a certain amount of skill is easily acquired, and in case of emergency «dilutees» could well deal with this work.

It is in manual welding that a high degree of skill is required of the welder. Even the use of contact electrodes can never entirely do away with the skilled man for certain specialised types of work, in particular those cases where cast steel of various types has to be welded to structural work, and where pre-heating is essential to the production of highly ductile joints, thereby precluding or making difficult the use of automatics. It is therefore in the best interest of all works to retain a hardcore of highly skilled welders who are able to perform some or all of these tasks.

It is recommended that works should institute their own tests for operatives, and apply these at the time of engagement of men, and also periodically throughout their employment. It is not thought that these tests per se are of any value, but the fact that they are being taken tends to keep men on their toes, and generally maintains a higher standard than would otherwise be the case.

(4) *Training of Supervisors.*

It is the authors' opinion that the training of supervisors be most efficiently carried out in the works, on the shop floor, under actual conditions of production. This training should obviously be supplemented by technical education on the theory lying behind the practice. It is considered essential to give these men their practical training whilst still very young, and then, if they prove their ability in the practical field, to pursue the theoretical side without delay whilst they are likely to assimilate it quickly. There is no substitute for hard, practical training, and if these supervisors do not get it before they are say 25 years of age, it is doubtful whether they will ever get it. Shop practice must be second

nature, and theory must be modified to suit practical limitations. New ways must constantly be found to give effect to the new techniques in welding, and it is the intelligent man with the shop training who is the most fitted to dress theory in the trappings of the hard facts of production practice. The ideal training for a welding supervisor is not less than 5 years on the shop floor, being given the necessary chances to organise and give orders to men who know their work, followed by a year or two at theory and design. A further period on the shop floor (preferably with a different Company, or at least a different Shop), will result in a first-class Supervisor capable of handling almost any class of work.

Men selected for supervisors posts should normally be trained to the job from their earliest days. Only in rare cases does the «workman», and he must be of exceptional ability, prove himself capable of rising above «operator level».

APPENDIX «A»

Man hours per ton

| Description | Total | Labour | Crop or Saw Guilhotine Plane Gas Cut | Template | Mark & Drill | Smith, Chip, Paint, Fit- ting Shop Joiners | Plate including helpers | Weld |
|--|-------|--------|---|----------|-----------------|---|-------------------------------|----------|
| Steam Generating Station excluding bunkers ... | 42.81 | 8.8 | 2.54 | 1.94 (1) | 2.53 | 5.4 | 14.5 | 7.1 |
| 53'0" Span All Welded Plate Girder Bridge ... | 51.10 | 8.1 | 7.21 | 0.64 | 1.44 | 16.81 (2) | 9.1 | 7.3 |
| Heavy Twin Plate Gir- ders with varying flan- ge thicknesses... .. | 54.86 | 12.95 | 7.50 | 0.39 | — | 2.62 | 15.0 | 16.4 (3) |

NOTES:

- (1) Includes for final checking of all dimensions after fabrication by template-maker.
 (2) Includes 10.14 man/hours in the Fitting Shop in the fabrication of the bearings.
 (3) Includes for pre-heating of flanges for making butt welds.

SUMMARY

Some of the main problems facing fabricators of welded structural steelwork are considered and certain methods of overcoming them are suggested.

It is shown that the many types of structure in design for welding can offer savings in weight of steel employed, and further, that the cost per ton for welded construction is not inevitably higher, and, in fact, in many cases this cost is actually less.

It is suggested that the main method of reducing cost lies in the extended use of automatic welding machines, and consequently in the

improvement in methods of setting up for welding and in the manipulation of weldments. The use of automatic machines also assures a more constant quality of weld metal, and invariably obviates any difficulties of heat in-put where the welding of high tensile steels is concerned. It is emphasised that new tests are required to measure notch ductility in parent metal, and that homogeneity in this parent metal is of great importance.

ZUSAMMENFASSUNG

Der Beitrag enthält die Darstellung einiger der Hauptprobleme, denen der Hersteller geschweisster Stahltragwerke gegenübersteht, zusammen mit den Vorschlägen von gewissen Methoden zu deren Ueberwindung.

Es zeigt sich, dass die vielen zum Schweißen vorgeschlagenen Bauwerksarten Ersparnisse im benötigten Stahlgewicht bieten können und weiter, dass die Kosten pro Tonne geschweisster Konstruktion nicht unbedingt höher, sondern in verschiedenen Fällen tatsächlich niedriger sein können.

Die beste Methode zur Kostenverringering liegt nach der Meinung der Verfasser in einer ausgedehnten Verwendung von automatischen Schweißapparaten und im Zusammenhang damit in der Verbesserung in bezug auf Handhabung der Schweißeinrichtungen und Bereitstellung der zu schweißenden Werkstücke. Die Verwendung automatischer Maschinen sichert eine konstantere Schweißmetallqualität und diese Unveränderlichkeit räumt jegliche Schwierigkeiten mit Hitzeeinschlüssen aus dem Wege, was das Schweißen hochwertiger Stähle anbetrifft. Nachdrücklich wird auf die Notwendigkeit neuer Versuche zur Messung der Kerbschlagzähigkeit im Schweißmetall hingewiesen, wobei die Homogenität dieses Schweißmetalls von grosser Bedeutung ist.

RESUMO

O autores consideram alguns dos problemas principais que constructores de estruturas soldadas têm de encarar e propõem alguns meios de os resolver.

Mostram que os vários tipos de estruturas projectadas para a construção soldada podem trazer economias sensíveis de material e ainda que o custo por tonelada de um conjunto soldado, além de não ser inevitavelmente mais elevado, pode de facto, em muitos casos, ser francamente menor.

Os autores são de opinião de que o método mais efectivo para reduzir os preços de custo reside no emprego generalizado de dispositivos de soldadura automática e, portanto, na melhoria dos métodos de posicionamento das peças a soldar e de manipulação dos conjuntos soldados. O emprego dos dispositivos automáticos assegura também uma qualidade mais constante do cordão e resolve invariavelmente os problemas de

aquecimento na soldadura de aços de alta resistência. Insiste-se na necessidade de novos ensaios para determinar a ductilidade do metal de base e frisa-se que a homogeneidade do referido metal de base é de grande importância.

R É S U M É

Les auteurs considèrent quelques uns des principaux problèmes qui se posent aux constructeurs de charpentes métalliques et proposent un certain nombre de moyens pour les résoudre.

Ils montrent que les nombreux types de structures projetés pour la construction soudée peuvent présenter une économie d'acier sensible et que, de plus, non seulement le prix de revient par tonne de construction soudée n'est pas inévitablement plus élevé mais aussi que dans certains cas ce prix peut être considérablement plus faible.

Les auteurs pensent que la méthode la plus effective de réduire les prix de revient consiste à généraliser l'emploi de dispositifs de soudure automatique, et par conséquent à améliorer les méthodes de mise en position des pièces à souder et de manipulation des ensembles soudés. L'emploi de dispositifs automatiques assure également une qualité plus constante du cordon de soudure et résoud invariablement les problèmes d'échauffement dans la soudure des aciers à haute résistance. Ils insistent sur la nécessité de disposer de nouveaux essais pour la détermination de la ductilité du matériau de base et sur l'importance capitale de l'homogénéité de ce matériau.

III c 2

Verschiedene Schweissverfahren bei der Ausführung geschweisster Stahlbauten

Diversos processos de soldadura utilizados em construção metálica

Différents procédés de soudure employés en construction métallique

Welding methods for the execution of welded steel structures

DR. CURT F. KOLLBRUNNER

Direktor der A. G. Conrad Zschokke

Zürich

I. *Einleitung.*

In den letzten Jahren hat die Lichtbogenschweissung überzeugende Fortschritte gemacht. Hand in Hand damit wurden die Qualitätsansprüche von den Stahlkonstruktionswerkstätten weiter gesteigert, so dass heute grosse Einsparungen an Gewicht und Arbeitszeit erzielt werden.

Die Prüfung der Schweissnähte erfolgt auch heute noch meist durch das bewährte Röntgen. Dabei ist es unerlässlich, dass jede gute Stahlkonstruktionswerkstätte ihre eigenen Röntgenapparaturen besitzen muss, damit die Schweisser stets überwacht werden können. Nur stichprobenweise alle paar Monate durchgeführte Kontrollen genügen nicht. Für den in der Schweiz nur *angelernten* Beruf des Schweissers (gibt es doch immer noch keine offizielle Lehrzeit für diesen Beruf) dienen diese Röntgenaufnahmen als gutes Unterrichtsmaterial zur Weiterbildung und Vervollkommnung.

II. *Handschweissung.*

1. *Schweissfehler.*

Die häufigsten Fehler bei der Handschweissung sind Poren, Schlackeneinschlüsse, Einbrandkerben, Wurzelfehler und Risse.

Poren ⁽¹⁾ entstehen meist bei Verwendung von feuchten Elektroden, bei zu langem Lichtbogen, zu hoher Stromstärke oder wenn die zu schweis-

⁽¹⁾ B. LAUTERBURG: Der Einfluss von Poren in geschweissten Stossnähten. Mitteilung der T. K. V. S. B., Nr. 11, Verlag V. S. B., Zürich, 1955.

senden Nähte nicht genügend metallisch blank sind. Heute weiss man, dass zur Vermeidung von Porenestern die Elektrode beim Zünden nicht sofort in der Schweissrichtung weiter zu führen ist, sondern dass kurz am Einsatzpunkt verweilt werden muss, bevor die Elektrode nach kleiner Rückwärtsbewegung über die Ansatzstelle in der Schweissrichtung weiter geführt werden soll. Man weiss auch, dass der Schweissprozess nicht durch senkrechtes Heben der Elektrode von der Naht abgebrochen werden darf, sondern dass die Elektrode über die Naht bei Verkürzung des Lichtbogens schnell hinwegstreichen soll und dann erst langsam abgehoben wird, oder indem man die Elektrode über die bereits aufgetragene Raupe ein Stück zurückführt. Ausserdem kennt man heute für jeden Elektrodendurchmesser und jede Schweissnaht die maximale Stromstärke, die nicht überschritten werden soll.

Schlackeneinschlüsse entstehen hauptsächlich, wenn der Schweisser die Schlacke durch Bürstenreinigung, Ausschleifung oder Nachmeisselung nicht genügend von der unteren Naht entfernt. (Schlackenzeilen).

Einbrandkerben treten meist auf, wenn nicht mit zweckentsprechenden Elektroden, guter Elektrodenführung oder mit zu hoher Stromstärke geschweisst wird. (Senkrecht oder Ueberkopfschweissen). Hauptsächlich bei dynamisch beanspruchten Bauteilen sind Einbrandkerben viel gefährlicher als Poren und Schlackeneinschlüsse.

Wurzelfehler entstehen durch unvollständiges Durchschweissen der Wurzelzone. Sie treten auf, wenn der Spalt in der Wurzel zu klein ist, wenn mit zu dicken Elektroden geschweisst wird oder wenn die Ausmeisselung nicht sachgemäss erfolgte.

Risse sind unter allen Schweissfehlern die gefährlichsten. Man weiss, dass Risse infolge von Wurzelfehlern, Schlackeneinschlüssen, Poren und Lunkern entstehen können. Gute Stahlkonstruktionswerkstätten stellen daher einen genauen Schweissplan auf, d. h. einen Plan, der angibt, in welcher Reihenfolge geschweisst werden muss, damit die Schweissspannungen möglichst klein gehalten werden können. (Nachmeisselung gefährdeter Stellen!) Meist liegt der Grund für die Rissebildung im Werkstoff selbst, (Kohlenstoff, Schwefel, Phosphor), oft aber auch in der falschen Wahl der Elektroden. Nach den heutigen praktischen Erfahrungen sollen unlegierte Stähle mit höheren Gehalten an Kohlenstoff (0,25 %), Schwefel (0,05 %) und Phosphor (0,05 %) sicherheitshalber mit basischen Elektroden geschweisst werden⁽²⁾. Die richtige Wahl der Elektroden ist heute keine Geheimwissenschaft mehr; der freundschaftliche Austausch der gemachten Erfahrungen nimmt immer mehr zu.

Diese oben aufgezählten häufigsten Schweissfehler können heute, bei enger Zusammenarbeit zwischen Stahlbaukonstrukteur, Betriebsleiter, Schweissmeister und Schweisser vermieden oder auf alle Fälle auf ein ungefährliches Minimum reduziert werden. Dazu gehört jedoch nicht nur eine im Konstruktionsbureau entwickelte sachgemässe Schweisskonstruktion, sondern auch eine gründliche Materialkenntnis, die Kenntnis und Wahl der günstigsten Elektroden, eine Vorschrift für die beste Schweiss-

⁽²⁾ C. HÖRNEGREN: Die häufigsten Schweissfehler beim Lichtbogenschweissen. ESAB — Revue Nr. 3, 1954, (Hausberichte der Elektriska Svetsningsaktiebolaget, Göteborg).

folge⁽³⁾ und eine langjährige Handfertigkeit der Schweisser die immer wieder zu überprüfen ist.

2. Schweissverfahren.

Währenddem früher mit wenigen Ausnahmen *saure* Elektroden verwendet wurden, ist man heute in der Schweiz bei Schweissungen mit hohen Beanspruchungen immer mehr zur Verwendung von *basischen* Elektroden übergegangen. Basische Elektroden sind «wasserstoffarm» oder «wasserstoffkontrolliert». Wenn man bedenkt, dass der vom Schweissgut aufgenommene Wasserstoffgehalt ausschlaggebend dafür ist, ob in der Uebergangszone oder im Schweissgut Risse entstehen oder nicht, so leuchtet es ein, dass die basischen Elektroden zur Vermeidung dieses gefährlichsten Schweissfehlers besser als saure Elektroden⁽⁴⁾ sind. Die Gründe zur vermehrten Verwendung von basischen Elektroden liegen in erster Linie in der Erhöhung der Beanspruchungen, in der Wahl von Stahlsorten höherer Güte und in der verlangten Sicherheit der Konstruktionen. Zudem hat die Entwicklung der Elektroden in den letzten Jahren gewaltige Fortschritte gemacht. Basische Elektroden waren früher mit ganz wenigen Ausnahmen nur am Gleichstrom verschweisbar. Die Stahlkonstruktionswerkstätten bevorzugten jedoch den Wechselstrom. Als Stromquellen werden Transformatoren verwendet. (Kleinere Anschaffungskosten gegenüber Schweissumformern, weniger Unterhaltskosten, da keine rotierenden Teile, bedeutend kleinere Blaswirkungen in den Ecken). Für Betriebe mit Transformatoren war somit fast vollumfänglich nur die Verschweissung mit sauren Elektroden einwandfrei möglich. Zudem musste ein Schweisser bei der Verwendung von basischen Elektroden über eine sehr grosse Fertigkeit verfügen, um mit dem zähflüssigen basischen Material einwandfreie Schweissnähte zu erstellen. Heute ist die Situation ganz anders. Die neuen basischen Elektroden können grösstenteils sowohl an Wechselstrom wie an Gleichstrom verschweisst werden; zudem erfordern sie heute keine spezielle Fertigkeit mehr vom Schweisser. Für Senkrecht — und Ueberkopf — Nähte sind sie den sauren Elektroden weit überlegen. Schweissgut und Schlacke sind vom Schweisser leichter zu beherrschen. Die Erfahrung zeigt, dass niedergeschmolzenes Schweissgut bei basischen Elektroden bedeutend weniger nichtmetallische Einschlüsse aufweist als dasjenige saurer Elektroden.

In den führenden Stahlkonstruktionswerkstätten werden daher alle dynamisch beanspruchten Konstruktionsteile wie auch die Zugnähte, wenn nicht ganz, so doch in den Grundläufen mit basischen Elektroden geschweisst. Rissbildungen sind dabei sehr selten und können ganz vermieden werden. Sind im zu verschweisenden Grundwerkstoff Seigerungen oder ist der Kohlenstoff —, Schwefel — oder Phosphorgehalt hoch, so können mit basischen Elektroden trotzdem brauchbare Nahtgüten erreicht werden.

(³) F. STÜSSI und C. F. KOLLBRUNNER: Schrumpfspannungen und Dauerfestigkeit geschweisster Trägerstösse. Mitteilungen über Forschung und Konstruktion im Stahlbau. Heft Nr. 4 Leemann, Zürich, 1946. (Siehe auch Mitteilungen aus dem Institut für Baustatik an der E. T. H., Heft Nr. 18).

(⁴) K. L. ZEYEN: Ueber neue Erkenntnisse und neuzeitliche Entwicklungen bei Schweisselektroden sowie deren betriebliche Bewährung. Sonderdruck aus «Technische Mitteilungen», Heft 2, 1955.

Vielfach geht man auch zur sogenannten gemischten Schweissung über, d. h. man verwendet bei ein und derselben Schweissnaht basische und saure Elektroden. So werden z. B. bei einer Stumpfnahht eines 20 mm Bleches die Wurzellage und die folgenden Lagen mit basischen Elektroden geschweisst, während für die Decklage saure Elektroden verwendet werden. Röntgen Untersuchungen haben gezeigt, dass bei richtiger Elektrodenwahl weder Poren noch andere Schweissfehler in der Naht auftreten. Die Festigkeitseigenschaften, welche durch eine solche Nahtausführung erzielt werden, sind bedeutend besser als bei Schweissnähten, die nur mit sauren Elektroden erstellt wurden. Die Unterschiede treten sehr deutlich bei tiefen Temperaturen (-25°C) zu Tage. (Kerbschlagprobe).

Man fragt sich nun, warum denn solche Nähte nicht überhaupt nur mit ein und demselben basischen Elektrodentyp hergestellt werden. Dies vor allem aus den folgenden zwei Gründen:

1. Auch heute noch weisen die mit basischen Elektroden geschweissten Deckläufe eine rauhere Oberfläche auf als wenn sie mit sauren Elektroden geschweisst werden. Dadurch nimmt die Festigkeit ab.
2. Die Abschmelzleistungen der basischen Elektroden sind geringer als diejenigen der sauren Typen; zudem erfordert die Schlackenentfernung mehr Zeit. Ausserdem müssen basische Elektroden in absolut trockenem Zustande verschweisst werden, damit keine Poren entstehen. (Trocknungseinrichtungen). Diese Faktoren verteuern die basische Schweissung.

Durch die gemischte Schweissung wird dieser Verteuerung entgegengetreten. Neuerdings ist dies in noch vermehrtem Masse möglich, da die Decklagen mit *Hochleistungs-Elektroden*, die eine sehr gute Ausbeute aufweisen, ausgeführt werden können.

Voraussetzung für gemischte Schweissungen ist, dass das Schweissgut aller dabei verwendeten Elektroden sich miteinander «verträgt». Diesbezüglich werden zur Zeit grossangelegte Versuche in der Schweiz durchgeführt.

Die Preise der Stumpfschweissungen hängen noch stark von der Bearbeitung der Nahtwurzel ab. (Ausmeisselung, Ausschleifung, Aushobelung). Mit den *Tiefeinbrandelektroden* können diese teilweise stark lärmzeugenden Arbeiten grösstenteils vermieden werden. (Darüber sollten jedoch noch mehr Versuche durchgeführt werden).

III. Automatschweissung.

Wenn auch die Automatschweissung die Handschweissung nie verdrängen kann, hat sie sich doch in den letzten Jahren in grösseren Betrieben stark ausgebreitet. In den nächsten fünf Jahren wird sie in der Schweiz an Arbeitsvolumen sicher der Handschweissung ebenbürtig.

Oft wird die erste Lage von Hand mit einer basischen Elektrode geschweisst, währenddem alle weiteren Lagen automatisch aufgetragen werden. Dabei werden bei richtiger Wahl von Draht und Pulver sehr

gute Resultate erhalten. Ein Ausmeisseln oder Ausschleifen der Wurzel ist nicht nötig; zudem ist bei Mehrlagenschweissungen kein Wert mehr auf eine einwandfreie Schlackenentfernung zu legen. Durch das mit hohem Strom erzeugte grosse Schmelzbad und die grosse Einbrandtiefe werden die Schlacken von der vorherigen Schweisslage an die Oberfläche gespült.

IV. *Innere Vergütung.*

Ich verweise auf das Heft Nr. 9 der Mitteilungen der T. K. V. S. B. (5).

ZUSAMMENFASSUNG

Da basische Elektroden bessere Güteverhältnisse der Schweissnähte ergeben, als saure Elektroden, somit eine erhöhte Sicherheit gegen Spröd — und Trennbruch erzielt wird und ausserdem bei Stählen mit höheren Kohlenstoffgehalten noch rissfest und bei Stählen mit höheren Schwefelgehalten noch porenfrei gearbeitet werden kann, werden in der Schweiz jetzt bedeutend mehr basische als saure Elektroden verwendet und zwar hauptsächlich für hoch beanspruchte Bauteile. Meist wird die gemischte Schweissung (innen basisch, aussen sauer) bevorzugt.

RESUMO

Na Suíça, a técnica moderna de soldadura dá a preferência aos eléctrodos básicos, tanto nas construções submetidas a esforços dinâmicos como nas soldaduras submetidas a esforços de tracção; o emprego desses eléctrodos confere às soldaduras características muito mais favoráveis do que as obtidas com eléctrodos ácidos. Também se emprega bastante a chamada soldadura mixta, em que se utilizam na mesma soldadura, eléctrodos básicos para os cordões interiores e eléctrodos ácidos para o cordão exterior.

Como é natural, este tipo de soldadura só pode ser utilizado quando o metal de adição de ambos os tipos de eléctrodos é compatível. Estão a realizar-se na Suíça importantes ensaios a este respeito.

A soldadura automática está tomando uma importância crescente na Suíça.

RÉSUMÉ

En Suisse, la technique moderne de soudure donne la préférence aux électrodes basiques tant pour les constructions soumises à des efforts dynamiques, que pour les soudures sollicitées à la traction, l'emploi de

(5) E. BRANDENBERGER, H. PREIS, H. E. TUCHSCHMID, C. F. KOLLBRUNNER: Untersuchungen zur Frage der inneren Vergütung von Mehrlagen — Schweissungen. Mitteilungen der T. K. V. S. B., Nr. 9. Verlag V. S. B. (Verband Schweiz. Brückenbau- und Stahlhochbau-Unternehmungen), Zürich, 1954.

ces électrodes conduisant à des caractéristiques de soudure bien plus favorables que celles obtenues avec des électrodes acides. Souvent on adopte la soudure dite mixte, en employant pour une même soudure, des électrodes basiques pour les cordons intérieurs et des électrodes acides pour la dernière passe. Naturellement cette soudure mixte n'est applicable que si les matériaux d'apport des électrodes employées sont compatibles. Des essais importants à ce sujet sont en cours d'exécution en Suisse.

La soudure automatique prend chaque fois plus d'importance en Suisse.

S U M M A R Y

In Switzerland, the modern welding technique gives the preference to basic electrodes for steel constructions submitted to dynamic efforts as well as for welded seams under tensile stress; this kind of electrodes confers much better characteristics to the seam welds than those obtained by the use of acid electrodes. Quite often, the so called mixed welding is adopted, where in the same welding seam, basic electrodes are used for the inner layers while acid electrodes are used for the cover weld.

The welding material of both electrodes should naturally be «compatible». Important tests on this subject are now being carried out in Switzerland.

The automatic welding is gaining importance in Switzerland.