

Zeitschrift: IABSE congress report = Rapport du congrès AIPC = IVBH
Kongressbericht

Band: 5 (1956)

Artikel: Maintenance of steel structures

Autor: Palmer, M.F.

DOI: <https://doi.org/10.5169/seals-6004>

Nutzungsbedingungen

Die ETH-Bibliothek ist die Anbieterin der digitalisierten Zeitschriften. Sie besitzt keine Urheberrechte an den Zeitschriften und ist nicht verantwortlich für deren Inhalte. Die Rechte liegen in der Regel bei den Herausgebern beziehungsweise den externen Rechteinhabern. [Siehe Rechtliche Hinweise.](#)

Conditions d'utilisation

L'ETH Library est le fournisseur des revues numérisées. Elle ne détient aucun droit d'auteur sur les revues et n'est pas responsable de leur contenu. En règle générale, les droits sont détenus par les éditeurs ou les détenteurs de droits externes. [Voir Informations légales.](#)

Terms of use

The ETH Library is the provider of the digitised journals. It does not own any copyrights to the journals and is not responsible for their content. The rights usually lie with the publishers or the external rights holders. [See Legal notice.](#)

Download PDF: 15.10.2024

ETH-Bibliothek Zürich, E-Periodica, <https://www.e-periodica.ch>

IVd2

Maintenance of steel structures

Unterhalt von Stahlbauten

Conservação das construções metálicas

Entretien des charpentes métalliques

M. F. PALMER

M. I. C. E., M. I Struct. E.

Bromley

Introduction.

The changeover from the use of iron in structures to mild steel was taking place towards the end of the last century. There are examples to-day of painted iron bridges over a hundred years old, and steel bridges approaching seventy-five years of age in which, for the most part, the metal is in an excellent state of preservation. This proves that paint, once it has properly adhered to a steel surface, is an excellent protection against weather.

The paper mentions details which have proved faulty in existing structures, and suggests methods of repair. It indicates trends of present-day design, and outlines methods of preparatory treatments which are available for steel protection.

Repairs to Tower Bridge

Tower Bridge was opened to traffic in 1898, and is a steel structure. During the last two or three years, the bridge has been very closely examined, repaired and repainted [1].

Where the steelwork of the bridge has been accessible for maintenance, its condition is good, and there has been very little corrosion of the steel. There are, however, a few places in the bridge which have not been accessible since it was built.

At the start of the last war, as a safety precaution, the heavy cast iron ornamentations were removed from the overhead girders of the opening span, and this revealed corrosion which had taken place in the webs of the mild steel outer channels forming the bottom boom of the

lattice girders. These channels were repaired by burning out sections of the web 12" long and 4" deep and butt welding in new plates, working along the boom until the total length of repair was sufficient to replace the corroded area.

Other places needing attention were the four outer corners of the opening span near the pivots of the bascules. The space between the bascules and the fixed steelwork at these points was only about 9 inches wide, and as a consequence, the steel surfaces which shadowed each other had not been painted since the bridge was erected. It was possible to see, however, that considerable corrosion had taken place on some of the web plates where water had run down from the road surface; also that some of the rivet heads had practically corroded away, while others had conical heads of various sizes.

To strengthen the girders, a system of web laticing was added as shown in Fig. 1, thus making the web plates more or less superfluous at these points. Manholes were then constructed as shown. By placing these manholes in suitable positions and rotating the bascules it was found possible to gain access to all parts which were previously inaccessible. When the manholes were not in use, cover plates were screwed on, in order to reduce draughts.

Rivets with badly corroded heads were cut out and replaced with high tensile steel turned and fitted bolts, the holes being reamed out to suit. In all cases, the working space was very confined, and replacing with rivets was not a practical proposition.

During the progress of the work, an investigation was made into the feasibility of welding round corroded rivet heads so as to avoid the work involved in cutting out the rivets and replacing with bolts. Test pieces were prepared as shown in Fig. 2.

Test piece (a) was a $2\frac{3}{4}" \times \frac{1}{2}"$ flat drilled centrally with a $\frac{15}{16}"$ diameter hole and filled with a $\frac{7}{8}"$ diameter rivet.

Test piece (b) was similar, except that the head of the rivet was ground to simulate a corroded head such as existed on the bridge. This head was then welded round as shown.

Test piece (c) was made with the object of testing whether the rivets were liable to pull out when tested in double shear.

Two test pieces of each type were tested. The results were as follows:

<i>Test Piece (a).</i>	No. 1 Tons	No. 2 Tons	Average Tons
Actual load to cause yield	25.14	25.83	25.48
Actual load to cause failure	31.40	30.74	31.07
 <i>Test Piece (b).</i>	 No. 1 Tons	 No. 2 Tons	 Average Tons
Actual load to cause yield	26.12	25.60	25.86
Actual load to cause failure	38.55	38.21	38.38

In the first test (b), the piece fractured across the parent metal at the hole and round the throat of the weld on one side of the hole. In the second test, the piece fractured across the parent metal at the hole and through the weld.

Test Piece (c).

Actual load to cause failure by double shear of both the rivets

No. 1 Tons	No. 2 Tons	Average Tons
60.23	63.80	62.01

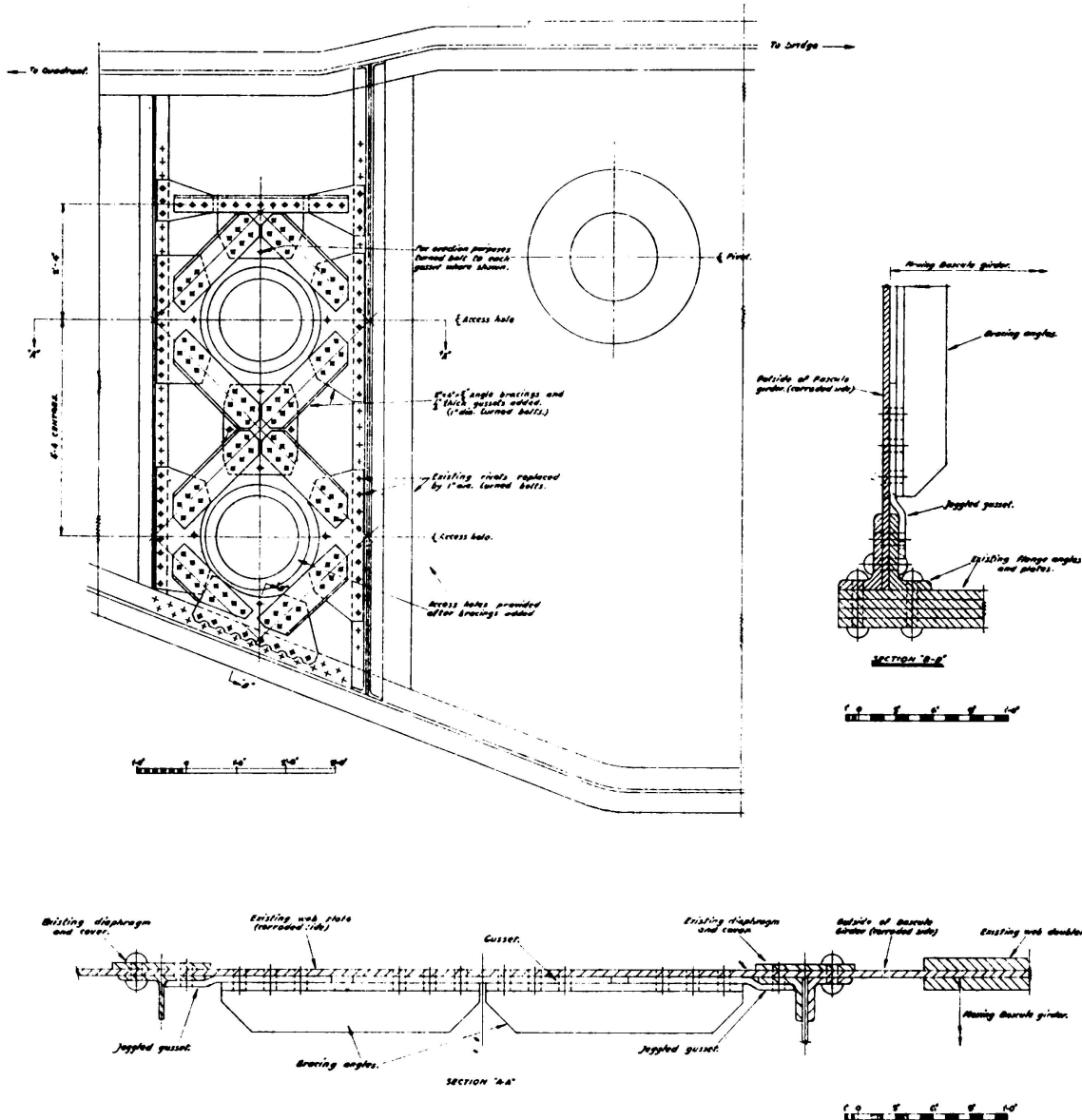

FIG. 1. Tower Bridge repairs. Arrangement of new steelwork for repair of corroded webs of moving bascule girders

By comparing test pieces (a) and (b), it will be seen that in repairing the rivet heads by welding round them, the ultimate strength of the plate at the weakest cross section, was increased by the value of the added weld metal. In this test, the increase was $38.38 - 31.07 = 7.31$ tons or 23%. This is a very valuable addition, especially as the web will have also corroded at this point.

The results given by test piece (c) show that after repair, the rivets were capable of taking their original shear load.

This method of repair was not used to a large extent on Tower Bridge because the working spaces proved to be too confined for welding, but it provides a cheaper way of making good than by cutting out corroded rivets and replacing with new rivets or fitted bolts. Where the original

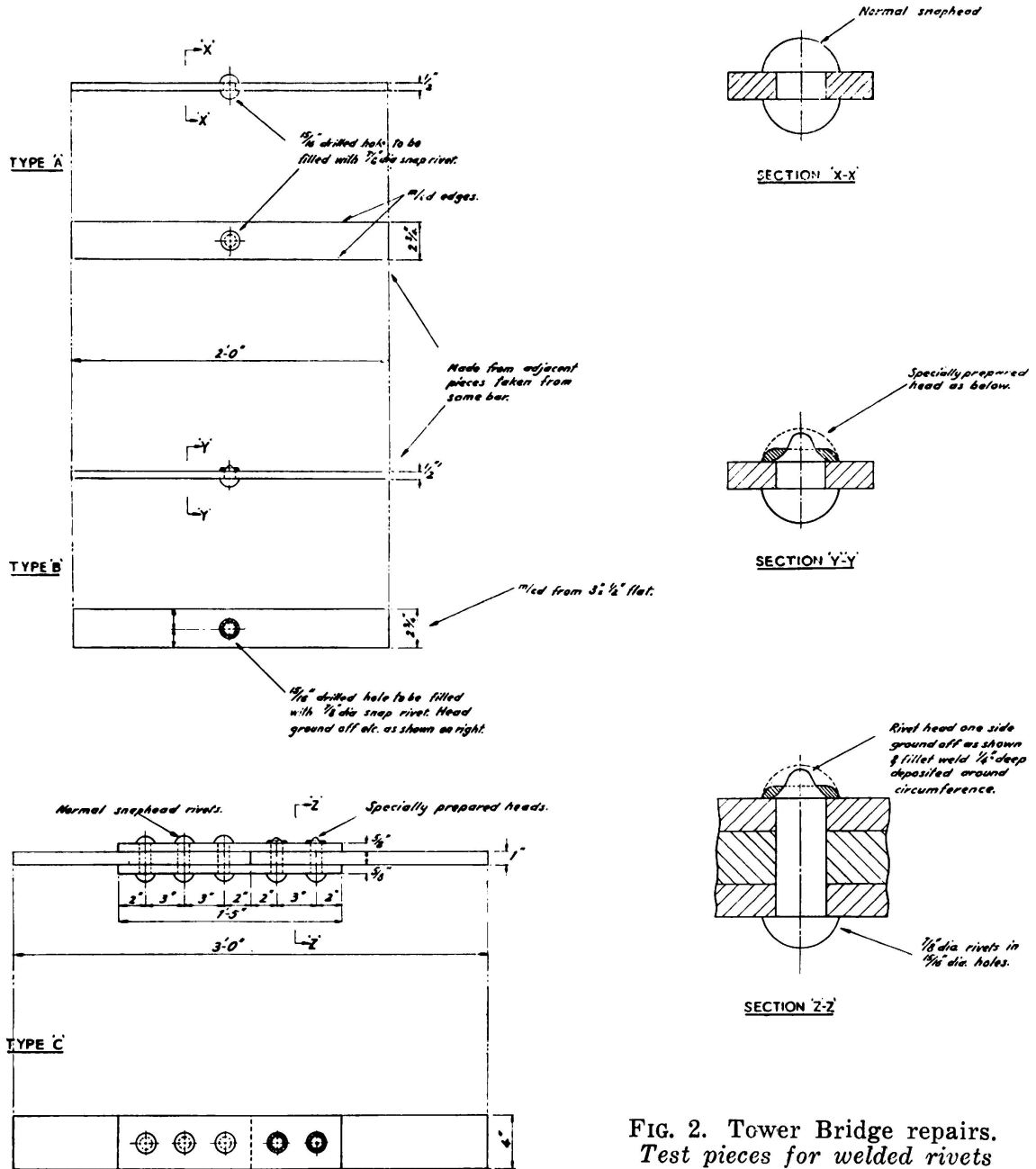

FIG. 2. Tower Bridge repairs.
Test pieces for welded rivets

rivet holes were punched and not reamed out after the parts were brought together, as was so often the case, it has been found impossible to drive out the rivets after the heads have been cut off. In such cases, they have had to be drilled out, which is an expensive process.

It is important to wire brush rusty surfaces prior to welding, since the absorption of an undue amount of rust into the weld metal could result in cracks in the welds which might propagate into the parent metal.

Faults in structures, and some remedies.

Where costly repairs to structures have been necessary, the causes can usually be traced to a lack of appreciation of the necessity for reasonable access to all parts for maintenance purposes, or to the existence of pockets capable of holding dirt and moisture. In bridges, parapet walls have been built so close to plate girders as to make the webs at the supports inaccessible on one side. In many cases, the girders sit on wide piers or abutments, making the bottom flanges of the

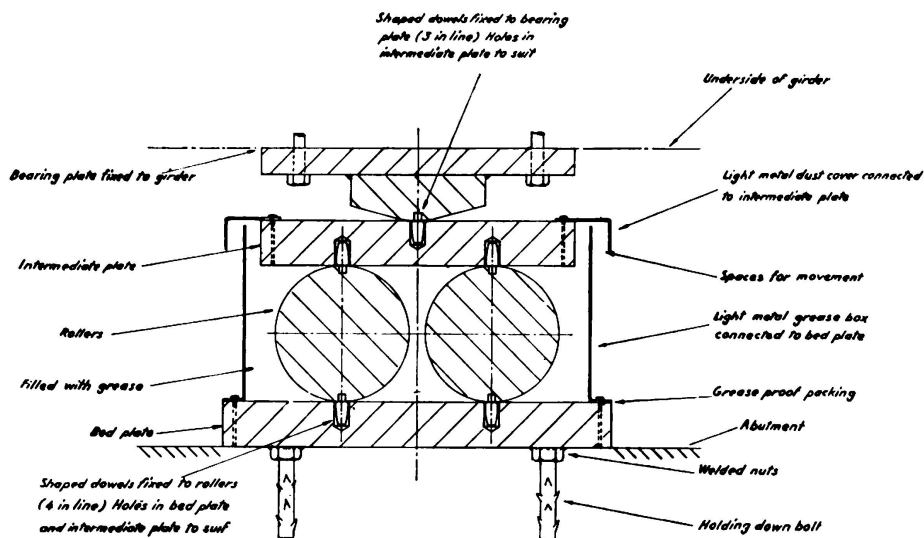

FIG. 3. Expansion bearings

girders inaccessible at the ends for the width of the pier. Bottom booms of lattice girders were sometimes in the form of a trough, thus collecting dirt and moisture; longitudinal timbers carrying tracks were laid in recesses in steel plated decks, and timbers were bolted to the top flanges of main girders and cross girders; all these and similar details have proved to be points of severe corrosion.

Modern practice leaves the ends of the girders clear of obstructions, and in some cases, bearings are set on pedestals in order to give room for access to the bearings and to tops of piers and abutments. Timber is now seldom used for decks of bridges.

Other common faults disclosed by the passage of time are the placing of rivets too far in from the edges of multiple flange plates and the spacing of rivets too far apart in the outer rows. This allows moisture to penetrate between the plates, resulting in rust forming between the surfaces and forcing the plates apart. Where this has happened, little can be done except to clean out the rust for as great a depth as possible, paint the surfaces with red lead and fill in the space with a suitable mastic. In railway bridges, cross girders has been designed as simply supported at their ends, but when detailed, have been partially fixed by means of end cleats. This results in the failure of the cleats in course of time through high stresses and fatigue.

In some cases, roller expansion bearings have not been easily accessible and have become completely corroded, and, in effect, fixed. It is now common practice to encase such bearings in grease boxes having dust covers, which ensures that no further attention is required for a number of years. This is exemplified by Rochester Bridge, which was reconstructed in 1912. The expansion bearings were left exposed, but in 1930, owing to the troubles from dust and dirt, they were completely encased and packed with grease. No further attention has been necessary, and the bearings are working well. Fig. 3 gives an example of a simple enclosed bearing.

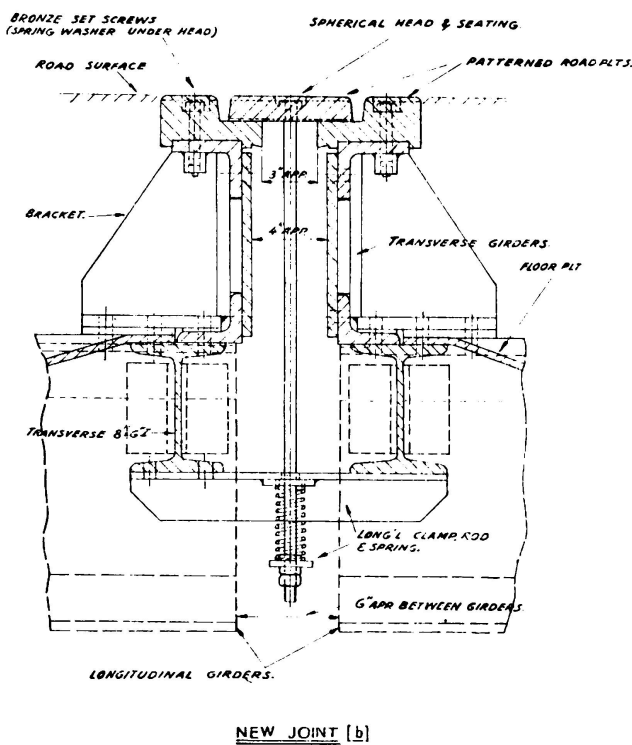
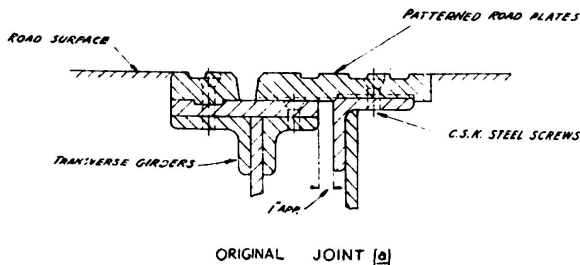

FIG. 4. Rochester bridge. Section Through expansion joints

Expansion joints in decks of road bridges require careful consideration. Fig. 4 (a) shows a detail of one of the original joints on Rochester Bridge. The overhanging plates which were held down by countersunk screws were continually working loose. Owing to a slight movement of one of the abutments over a period of years, the expansion gap was gradually reduced and it became necessary to renew the joint. The detail shown in Fig. 4 (b) was adopted. It will be seen that the plate bridging the gap is loose, apart from being held down by springs which are adjustable from the underside of the bridge. This reconstructed joint has been in existence now for a few years and has proved successful.

In external crane gantry structures, a source of weakness has proved to be the inadequate fixing of the crane rails. Rain water penetrates between the top of the crane girders and the bottoms of the rails and a layer of rust is formed. This rust is broken under the action of the crane wheels, and the process is repeated. In course of time a longitudinal trough is worn in the top of the girders, causing a thinning of the top flanges. The bottom of the rail also thins from corrosion and is weakened. Unfortunately, continuous welding of rails to girders produces difficulties which are not easily overcome. Due to the high carbon content of the rails, cracks are liable to occur in the welds and may propagate into the girder itself. One solution is to fasten the rails by high tensile bolts

placed closely enough to make a watertight joint, the bolts being fitted with lock washers. This method also allows easy replacement of the rails when this becomes necessary. It will be necessary to use clips for the smaller sizes of bridge rails. Joints in rails, if badly made, are a source of wear on the crane and the gantry and are noisy. The author favours skew cut joints with the rails tightly butted.

Tendencies of modern design.

Welded construction contributes greatly to ease of maintenance and presents plain surfaces for cleaning and painting.

Details of two unusual welded plate girder railway bridges have recently been published, [2] having all-welded steel plate decks. One bridge has ten spans and a walkway span placed side by side and sealed by welding so as to form a completely watertight deck, Very little steelwork in the form of the upper parts of the girders is exposed above the deck for maintenance, whilst under the deck, maintenance should be light due to absence of water. The other bridge is in three spans carrying a single track, and in this case, the plated deck stops short of the webs of the girders so as to enable the girders to be completely painted. This bridge is curved in plan to suit the radius of ten chains of the track it carries.

In road and rail bridges of lattice girder design, the recent practice of forming the top and bottom booms and internal members of welded construction, and using bolts or rivets at intersections only, has much to commend it from a maintenance point of view. All-welded lattice girders for footbridges having top and bottom booms and internal lacings of single members, are in effect monolithic frames and are easily maintained.

Protection of steelwork.

The most important consideration is the preparation to be carried out on the steel surfaces prior to painting. This may take the form of wire brushing, pickling, flame cleaning or grit blasting.

In all cases, the longer the steel has been allowed to «weather», the easier will be the removal of the mill scale. It will often be advisable to omit the coats of shop paint to allow extra time for «weathering». Site painting should be carried out only in the summer months where this is practicable.

One shop coat of paint is not worth applying, owing to the short time in which it fails. This remark also applies to the coat of cement wash which is sometimes called for where steelwork is to be buried in concrete.

Descriptions of the more usual methods of preparing and protecting structural steelwork are given in the remainder of this paper.

Wire Brushing.

The simplest method of preparation is hand cleaning using a wire brush in conjunction with hand scraping or hand chipping. This is

intended to remove only loose mill scale, rust and old paint. There have been endeavours recently [3] to set standards to which this should be carried out, such as the cleaning obtained by vigorously hand brushing a test area with a new, commercially acceptable, wire brush at a rate of two square feet per minute.

Grit Blasting.

A similar attempt has been made to classify blast cleaning prior to painting according to the results required. Three graduations of finish are given.

Blast cleaning to «white» metal, such as is necessary for metal spraying.

Commercial blast cleaning of a lower standard, but satisfactory for most practical purposes. This is defined as the finish given by dry blasting under specified conditions at the rate of 3 square feet per minute.

Brush-off blast cleaning, considered adequate for mildly corrosive conditions, and is the finish obtained by blasting at the rate of 8 square feet per minute.

Dry blasted surfaces should be brushed or vacuum cleaned before coating, and the initial coating should be applied within a few hours of blasting, i. e., before any fresh rusting is visible.

Grit blasting is carried out either by an air blast or mechanical impeller. The process used must depend on the type of work to be treated and the quantity. At the present time, the air blast is the most universal, and is the only method for dealing with fabricated parts for bridges and similar structures and for normal quantities of any kind. Where large quantities of steel bars are to be treated and the workmanship amounts to no more than drilling, an automatic machine of the impeller type has been used.

A variation of the air blast method is Vacu-Blast — a process whereby the grit is collected by vacuum before it is able to disperse, which saves the operator wearing a mask. The process can be carried out in the fabricating shops, and the plant, being portable, can be taken to the job. This is particularly advantageous in the case of heavy girders. By means of special brushes it is possible to grit blast sections such as angles. In downhand positions, which would apply to most work carried out in the shops, the speed of operation is reasonable, but for vertical and overhead positions, the tubes are rather heavy and result in some slowing down, due to fatigue of the operator.

Cold Phosphating.

This treatment came to the fore during the last war, and its use has grown considerably. A chemical rust remover is used and thoroughly brushed in. After allowing time for the action to take place, it is wiped off and the phosphate treatment applied with a brush. This is allowed to dry until a grey deposit forms, when the surface is ready for painting. For external work, it is important that the phosphate coat is not exposed

to rain or dew, which would dilute it. Should this happen, a further coat is applied.

Flame Cleaning.

The basis of the system is the passing of an intense oxy-acetylene flame over the surface, which has the effect of forcing off some of the scale, due to difference in the expansion of the scale and the parent metal. The burner consumes about equal quantities of oxygen and acetylene, and several passes of the flame may be necessary if the majority of the mill scale is to be removed. The surface of the steel is vigorously brushed when heated and the priming coat of paint applied while the surface is still warm.

Flame cleaning is more efficient in removing mill scale if the new steel has had some time in which to weather. A minimum period for weathering would appear to be about three months.

On existing structures, old paint can be removed by this method, but in doing so, smoke and fumes are involved. In fresh air this is not objectionable, but in enclosed spaces, provision would have to be made to conduct these products away. These remarks apply with particular force if the paint coat contains lead.

Pickling.

To remove mill scale by pickling, steel bars or plates are immersed in a tank containing acid for two or three days. They are then removed and transferred to another tank for washing. The process is more suitable for plates for shipbuilding and tank making than for structural engineering, where members (flange plates, etc.) up to 60 ft. long are used. These would involve very large tanks. Furthermore, the quantities of similar sized plates are large for ship and tank construction, whereas, plates and sections for the structural trade are generally much more miscellaneous.

The mill scale having been removed, the steel surface will be more liable to rusting, and it is therefore necessary that fabrication should take place as quickly as practicable. Light rusting, however, would not be detrimental and could be removed by a rust remover prior to phosphating or by hand wire brushing immediately before painting.

Painting.

According to Dr. Hudson [3], no important structure should go into service carrying a paint film less than 5 mils thick (say three or four coats). In re-painting existing structures, sound adherent paint should be allowed to remain, the bad areas patch cleaned and brought up with enough coats of rust inhibiting priming paint to build up to a satisfactory level before giving the whole structure overall coats. Exposed areas should be feathered. Whilst paint may adhere to galvanised surfaces which have weathered, where there is any doubt, i. e., where a side of a building has been

sheltered by an existing building or an overhang, the surface should be treated by phosphating or other treatment before painting. Zinc dust primers are useful paints on galvanised surfaces where rust has begun to appear. Painting should not be applied when the temperature is below 40° F., or in rain, snow, fog or mist or when the relative humidity of the air exceeds 85 %, or to cold steel which is at a temperature of 35° F or more than 5° below air temperature. When steel is painted in hot weather, precautions must be taken to ensure a specified thickness of paint is obtained.

Metal spraying.

The spraying of structures with zinc and aluminium has been carried out for a number of years, and several examples exist to show the benefits obtained.

Careful preparation of the surface to be sprayed is essential; it is necessary to have a sand or shot blasted finish down to white metal, all mill scale having been removed. The surface, which must be sprayed before oxydisation takes place, forms a mechanical key for the metal coating. The metal, which is applied by means of a flame pistol, can be of any desired thickness, depending on the number of coats applied. The usual thickness is 0.003" per coat, but it is not usual to apply more than two coats. The thickness can be checked by a suitable comparator.

The metal coatings are fairly easily scratched, but if the metal is zinc, the steel is protected by the sacrificial action of the zinc. Aluminium has also been shown to protect steel sacrificially, but to a lesser extent than zinc. Very little heat is applied to the article, and distortion is negligible.

The first coat of paint must be chosen so as to be compatible with the metal coating. Lead based paints were thought at one time to be unsuitable, but this is not borne out by experience.

An example of metal spraying is the Menai Suspension Bridge, North Wales. This bridge was reconstructed in 1940 [4] and the new mild steel links forming the suspension chains were zinc sprayed on site by the Schori powder process in two coats to a thickness of .005". This was followed almost immediately by a priming coat of red lead paint. Three further coats of paint were given. According to latest reports, although this bridge stands in an exposed marine atmosphere, the original painting on the links remains intact after fifteen years, and is still in excellent condition. With the exception of the outside faces, which were repainted because of a change in the colour scheme, no additional coats of paint have been applied, and there is no sign of rusting. On the other hand, the deck steelwork, which was not zinc sprayed, has already had at least five additional coats of paint.

From this experience, it would seem that for any structure which is well-designed and metal sprayed, minimum metal thicknesses to allow for subsequent corrosion as called for in some specifications could be deleted.

Galvanizing.

When a structure is to be galvanized, members should be so designed that acid is not trapped and the spelter can run freely away when the article is lifted out of the bath. The pieces to be galvanized should be monolithic, i. e., in the form of a single bar, or a continuously welded member which is in effect acid-tight. The steel must be clean, and free from paint, oil or grease, otherwise the pickling will not be complete. White spirit is a useful medium for removing oil and grease. The galvanizing of members which have been built up by riveting at the usual structural pitch is not generally satisfactory since acid is liable to be trapped between the riveted surfaces and cause trouble at a later date.

Splatter around welds should be scraped off, and all slag removed from welds, otherwise the galvanizing will be faulty. Where the welds are made in other than very short runs, the slag is fairly easily removed by chipping using light pneumatic chippers, but this should be thoroughly done, especially at the boundaries of the welds.

When a complicated article has to be welded and the welds are short, slag inclusions will be more difficult to remove by chipping. Grit blasting may then have to be adopted.

The distortion suffered by an article during galvanizing depends on its shape, construction and stiffness. Members of box form are unlikely to be much affected, but mild steel channels and even joists when fairly long may assume a curvature and need straightening after galvanizing.

Conclusions of protection.

In enclosed buildings, the steelwork will be well protected by the ordinary coats of paint, provided the steel was well wire brushed and cleaned before the priming coat was applied, and that all painting was carried out under good conditions.

On the other hand we have steelwork in factories where processes which give off smoke or fumes are carried on day and night, and prevent maintenance from taking place except when the factories are shut down. These cases justify the best pre-treatment and painting systems.

Most structures will fall between these extremes, and each case will need special consideration to arrive at the most economical protective treatment.

ACKNOWLEDGMENTS AND REFERENCES

1. The author thanks Messrs. Mott, Hay & Anderson, Consulting Engineers, for permission to describe these repairs.
2. M. F. PALMER — *Fabrication and Erection of Steel Plate Girder Railway Bridges*. The Structural Engineer, December, 1954.
3. DR. J. C. HUDSON — *Steel Structures Painting Council. Specifications for Cleaning and Painting Steel Structures*. Critical Abstract, British Iron & Steel Research Association, May, 1953.
4. G. A. MAUNSELL — *Menai Bridge Reconstruction*. Journal of Institution of Civil Engineers. January, 1946.

S U M M A R Y

Particulars are given of a method used to repair corroded web plates and of the extra strength imparted to a member by welding round corroded rivet heads. Some details which have proved faulty in older structures are mentioned, and trends of modern design intended to avoid these are stated.

The protection of steelwork is discussed, including methods of removing mill scale in varying degrees according to the result required, and subsequent treatments prior to final painting.

ZUSAMMENFASSUNG

Es werden Besonderheiten einer Methode zur Instandstellung korrodierter Stehbleche gezeigt, sowie die spezielle Haltbarkeit, welche bei einer Konstruktion dadurch erreicht wurde, dass man korrodierte Nietköpfe rund herum schweisste. Einige Einzelheiten, welche sich in älteren Konstruktionen als fehlerhaft erwiesen haben, werden erwähnt und Richtlinien für moderne Entwürfe aufgestellt, um diese Fehler zu vermeiden.

Die Schutzmassnahmen für Stahlbauten werden behandelt, insbesondere Methoden zur ganzen oder teilweisen Entfernung der Walzhaut je nach dem verlangten Ergebnis, sowie weitere Behandlungen vor dem endgültigen Anstrich.

R E S U M O

Descreve-se em pormenor um processo empregado para a reparação de almas de vigas atacadas pela ferrugem e indicam-se elementos relativos à resistência suplementar introduzida numa viga pela soldadura das cabeças corroídas dos rebites. Mencionam-se também alguns elementos defeituosos das estruturas mais antigas e as medidas que se tomaram em projectos modernos para evitar a repetição desses defeitos.

Discute-se ainda a protecção das estruturas metálicas bem como os vários métodos empregados para remover a película de laminagem em função do grau de limpeza desejado e os diversos tratamentos usados antes da pintura final.

R É S U M É

L'auteur décrit en détail un procédé de réparation des âmes de poutres attaquées par la rouille et donne des renseignements concernant la résistance supplémentaire introduite dans une poutre par la soudure des têtes de rivets rouillées. Il décrit également certains éléments défectueux d'ouvrages anciens et les mesures prises dans les projets modernes pour éviter la répétition de ces défauts.

La contribution comprend encore une discussion de la protection des ouvrages métalliques ainsi que des divers moyens employés pour nettoyer la calamine selon le degré de propreté désiré et des différents traitements préparatoires avant la peinture finale.