

Zeitschrift: IABSE congress report = Rapport du congrès AIPC = IVBH
Kongressbericht

Band: 6 (1960)

Artikel: Development of continuity in precast prestressed construction

Autor: McHenry, Douglas / Mattock, Alan H.

DOI: <https://doi.org/10.5169/seals-7067>

Nutzungsbedingungen

Die ETH-Bibliothek ist die Anbieterin der digitalisierten Zeitschriften. Sie besitzt keine Urheberrechte an den Zeitschriften und ist nicht verantwortlich für deren Inhalte. Die Rechte liegen in der Regel bei den Herausgebern beziehungsweise den externen Rechteinhabern. [Siehe Rechtliche Hinweise.](#)

Conditions d'utilisation

L'ETH Library est le fournisseur des revues numérisées. Elle ne détient aucun droit d'auteur sur les revues et n'est pas responsable de leur contenu. En règle générale, les droits sont détenus par les éditeurs ou les détenteurs de droits externes. [Voir Informations légales.](#)

Terms of use

The ETH Library is the provider of the digitised journals. It does not own any copyrights to the journals and is not responsible for their content. The rights usually lie with the publishers or the external rights holders. [See Legal notice.](#)

Download PDF: 18.10.2024

ETH-Bibliothek Zürich, E-Periodica, <https://www.e-periodica.ch>

Val

Development of Continuity in Precast Prestressed Construction

Développements dans la réalisation de la continuité dans des ouvrages préfabriqués en béton précontraint

Herstellung der Durchlaufwirkung in vorfabrizierten, vorgespannten Bauwerken

DOUGLAS McHENRY

ALAN H. MATTOCK

Director of Development and Senior Development Engineer, respectively, Portland Cement Association Laboratories, 5420 Old Orchard Road, Skokie, Illinois, USA.

Continuity in Precast Bridge Construction

The precast prestressed concrete girder combined with a cast-in-place deck slab has been used extensively in highway bridge construction in recent years. The majority of these bridges have consisted of a series of simple spans. Since continuity between adjacent spans leads to well-recognized advantages, a study was made of various methods of creating continuity in precast prestressed concrete bridges. Several forms of continuity connection were considered [1], and it was decided to investigate in detail that form of connection in which continuity is created for live loads only by the embedment of deformed rein-

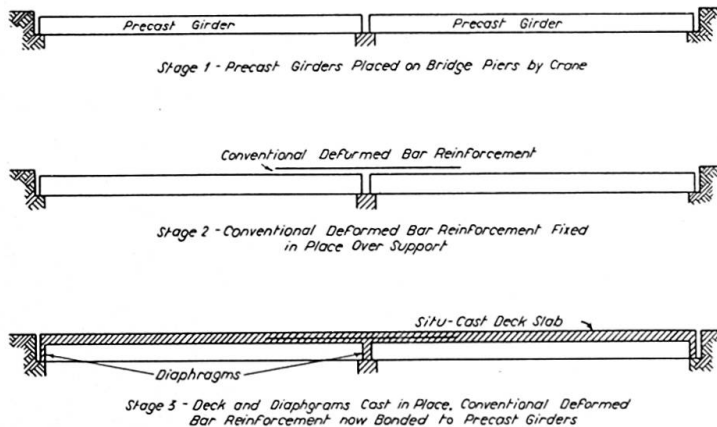

Fig. 1. Sequence of Construction of Continuous Precast Bridge.

forcing bars longitudinally in the cast-in-place deck slab over the interior supporting piers.

The sequence of construction when this form of continuity connection is used is set out in Fig. 1. The precast prestressed girders are placed on the bridge piers with the ends of girders in adjacent spans about six inches apart. The formwork for the deck slab and diaphragms is then erected, being supported by the precast girders. Conventional deformed reinforcing bars are next placed longitudinally in the deck slab over the intermediate piers. The transverse diaphragms, which enclose the ends of the girders and fill the space between them, are then concreted, together with the deck slab.

Experimental Program

The type of continuous construction described above combines precast, cast-in-place, prestressed, and normally reinforced concrete. The use of such a combination gives rise to several questions regarding the properties of structural concrete not covered by previous tests. A program of experimental work was therefore drawn up in nine stages to seek answers to these questions.

1. Girder Continuity

The first stage of the program was to check the behavior and strength of this type of connection when subject to static loading. As a case of extreme severity, a connection between girders without end blocks and without deflected strands was considered. In this case the precompression of the bottom flange at the ends of the girders is a maximum. The influence of prestress in the

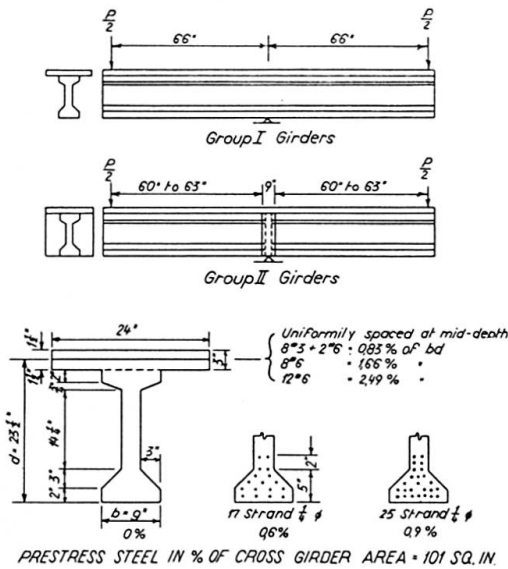

Fig. 2. Cross-Sections and Loading Arrangements of Test Specimens in Stage I.

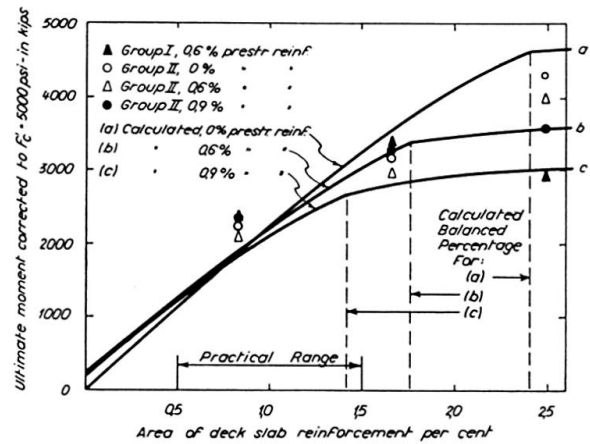

Fig. 3. Ultimate Moments for Groups I and II.

precast girders on the behavior of the connection would, therefore, be at a maximum.

In this first stage of the experimental program specimens were tested of the type shown in Fig. 2. The girders were supported at the mid-point and loaded at the two ends so as to produce negative bending. Loading was continued until failure occurred. The deck slabs contained various amounts of bar reinforcement, and three levels of prestress were used in the girders. The results of both groups of tests are shown in Fig. 3, where they are compared with the calculated relationships between ultimate strength of connection and the amount of continuity reinforcement in the deck slab. In these tests the amount of normal reinforcing bars in the deck, expressed as a percentage of (depth of girder \times width of bottom flange), was 0.83, 1.66, or 2.49%. The initial precompression of the bottom flange of the precast girders was 0, 2100, or 3200 psi. The ultimate strength of each connection measured in the tests was compared with the ultimate strength calculated neglecting any influence of precompression of the bottom flange of the precast member, and also with the strength calculated taking this precompression into account. It was concluded that, for the practical range of continuity reinforcement of from 0.5 to 1.5%, the influence of precompression of the bottom flange may be neglected in the calculation of the ultimate strength of this type of connection.

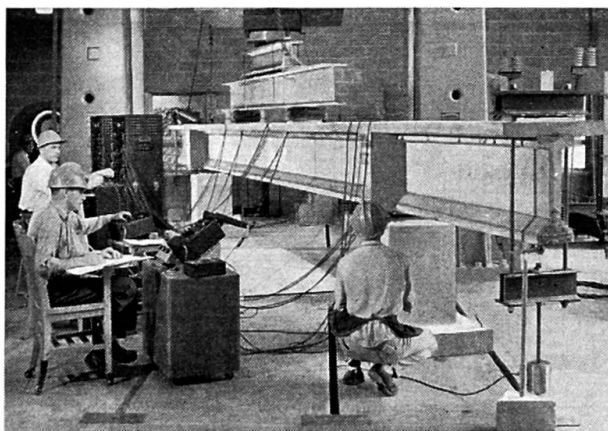

Fig. 4. Test of Continuous Girder from Group III.

Another group of specimens consisted of precast prestressed girders 22 ft. long joined to 6 ft. long precast girder stubs at their ends by deformed reinforcing bars placed in a deck slab cast on top of the precast girders. The 22-ft. spans were loaded at their third-points and loads were applied at the ends of the cantilevers so that no rotation of the ends of the 22-ft. spans occurred. A test is shown in progress in Fig. 4. The specimens behaved according to the elastic theory at service load level, and at ultimate strength redistribution of moments occurred so that ultimate strength as calculated by limit design was attained in all cases. It was therefore concluded that this type of connection

can be designed to behave satisfactorily both at service load level and at ultimate strength.

2. Horizontal Shear Connection

The transfer of horizontal shear between the precast girder and the cast-in-place deck slab is of vital importance in composite construction. The second stage of this experimental program was therefore concerned with the effectiveness of various means of horizontal shear transfer. The means considered as variables in the tests were: adhesive bond, roughness, stirrups, and shear keys.

Pilot tests were first carried out in which a short length of deck slab was pushed off a section of precast girder, as may be seen in Fig. 5. The slab was cast in a horizontal position and the specimen was rotated through 90° before test. The load was applied to the slab in a direction parallel to the joint, the

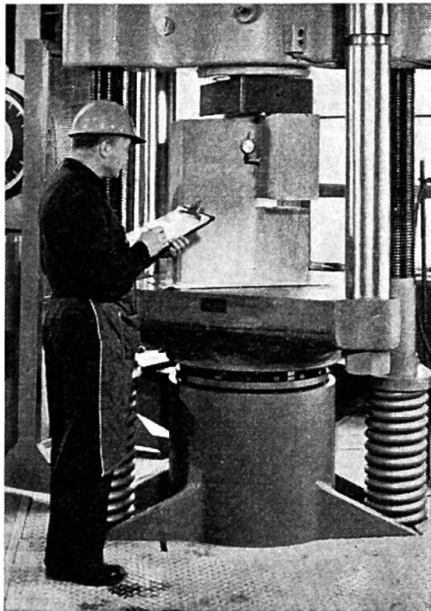

Fig. 5. Horizontal Shear Test using "Push-Off" Specimen.

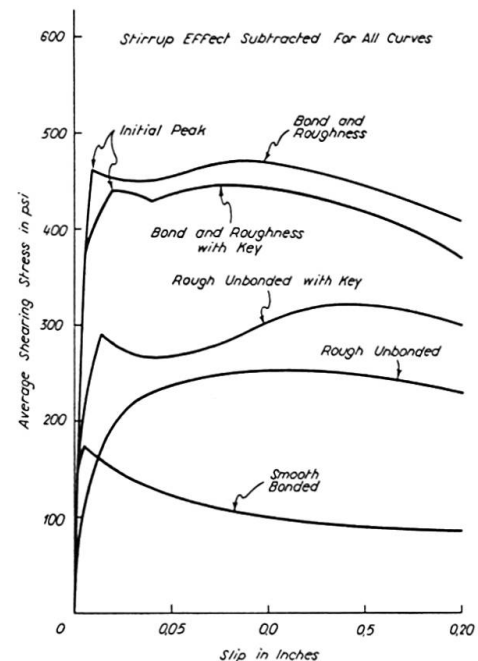

Fig. 6. Typical Shear-Slip Curves for "Push-Off" Tests.

line of action of the load being 1 in. from the contact face of the joint. The slip of the slab relative to the precast girder was measured using 0.0001 in. dial gauges. Typical shear-slip curves obtained in these tests are shown in Fig. 6.

The push-off tests were followed by tests of composite girders in which the slip of the deck slab relative to the precast girder was measured by a series of dial gauges along the length of the girders. The shear-slip curves obtained in the girder tests were found to have the same form as those obtained in the push-off tests, and to be closely related quantitatively.

From a study of the beam deflection curves, it was concluded that true composite action breaks down when the maximum slip reaches a value of about 0.005 inch. The girder tests indicate a maximum horizontal shearing stress for composite action of 500 psi for a rough bonded contact face, and 300 psi for a smooth bonded contact face. These limiting stresses correspond to concrete compressive strengths of 3000 and 5000 psi for the slab and girder respectively.

The tests demonstrated clearly that shear keys used with a rough bonded contact surface do not increase the strength of the connection. The slip required to develop the strength of the shear keys cannot occur until the bond between the precast and situ-cast concrete has been broken. On the other hand, stirrup reinforcement used in conjunction with a rough bonded contact surface was found to increase the limiting shear stress. For the half-inch diameter stirrups used, the increase in shearing stress was approximately 175 psi for each per cent of stirrup reinforcement crossing the contact surface.

The stage of the test program is described in detail in PCA Development Department Bulletin No. D 35, "Horizontal Shear Connections" [2].

3. Bridge Design Studies

At this stage, a tentative design was prepared for a two-span continuous highway bridge to carry the AASHO standard H 20-S 16 loading. This structure is shown in outline in Fig. 7. The design of the continuity connection,

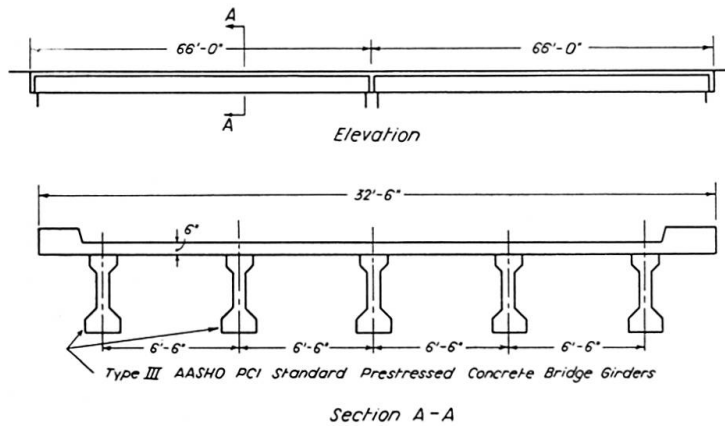

Fig. 7. Design Study Bridge.

and of the horizontal shear connection, were based on data obtained in the first two stages of this experimental program. As far as was possible, all other phases of the design were carried out in conformity with the American Association of State Highway Officials' "Specifications for Highway Bridges", or in accordance with the recommendations of the ACI-ASCE Committee on Prestressed Concrete. A two-span bridge was chosen for this study in order that it could be reproduced at half-scale on the test floor at a later stage in the

experimental program. However, certain problems were considered which are inherent in the application of this form of construction to bridges of more than two spans. These design studies brought out the need for additional test data, and further stages of the experimental program were planned. This phase of the investigation, together with stages 4, 7, and 8 of the experimental program, is described in detail in PCA Development Department Bulletin D 43 [3].

4. Flexural Strength

It was decided next to extend the work carried out in the first stage of the investigation by testing a half-scale model of a single continuous girder. The member tested represented one girder and its portion of deck slab taken from the bridge design studied in stage three. The girder was loaded by hydraulic rams in a manner designed to simulate the distribution of loads in the H 20-S 16 equivalent lane loading. The loads were arranged so as to result in the most severe bending moment conditions at the center support section of the girder. The connection behaved in a satisfactory manner, and full redistribution of bending moments was achieved in the girder at ultimate strength. The variation of center support moment with applied load throughout the test is shown in Fig. 8. The maximum load sustained by the girder was approximately seven

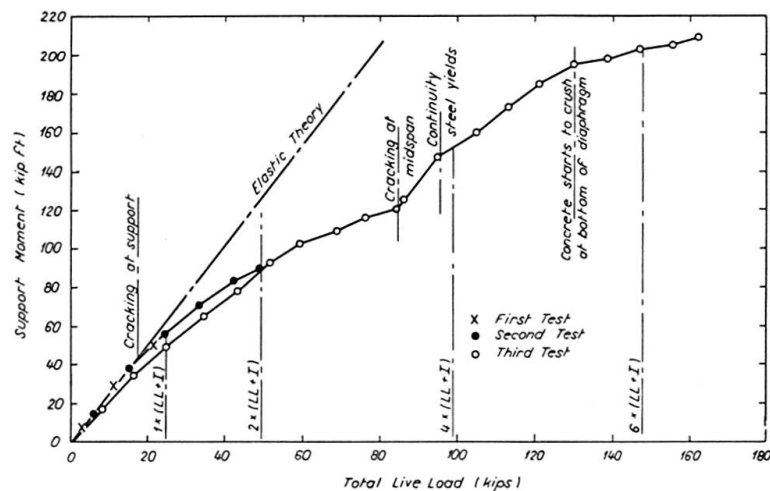

Fig. 8. Test of Continuous Composite Prestressed Bridge Girder, Variation of Center Support Moment with Increase in Load.

times the design load, plus the self-weight of the girder. It appears that substantial economies could arise from the development of a form of limit analysis suitable for use in bridge design, and also if some tension were permissible at the bottom face of a prestressed girder under design load. Further research is necessary on both these subjects before recommendations could be made which would cover all eventualities.

5. Shearing Strength

In the region of the continuity connection the girders were designed for flexure as reinforced concrete members, so the question arose as to how this same region of the girders should be designed for shear. Half-scale composite girders were loaded by a group of point loads to simulate the distribution of wheel loads of the standard H 20-S 16 design vehicle. The girders tested were single-span girders with a tied-down cantilever at one end. By suitably varying the tie-down force at the end of the cantilever independently from the vehicle loads, it was possible to simulate in the single span the conditions which would exist in one span of a two-span continuous girder, when subject to the same external loads in each span. A typical test is shown in progress in Fig. 9. The

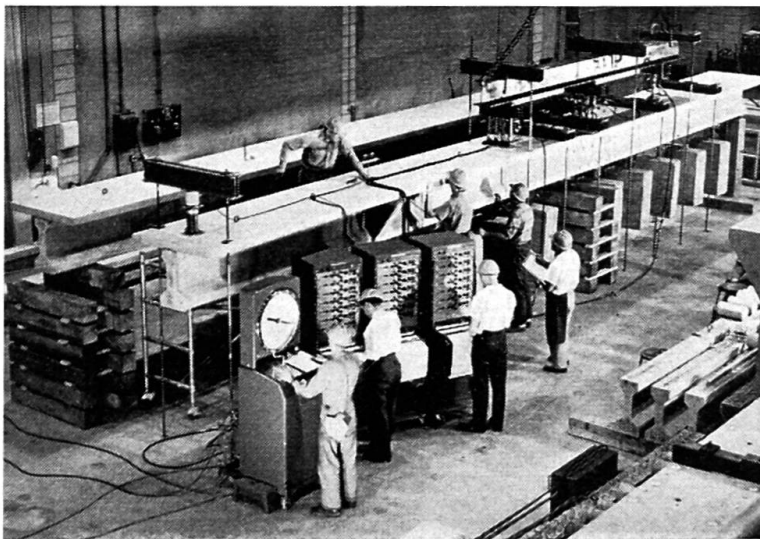

Fig. 9. Shear Test of Composite Prestressed Girder.

blocks seen hanging from the girder were used in many of the tests so that the dead-load stresses would be the same in the half-scale model as in the full-scale prototype. The variables considered in the shear tests were the amount of web reinforcement and the location of the applied loads.

Results from tests of 16 girders indicate that the presence of prestress in the precast member has a beneficial influence on the ultimate shear strength of the composite continuous girder. Flexural cracks due to negative bending at the support did not appear to accelerate the formation of the diagonal tension cracks which subsequently led to failure of the girders. This stage of the program is fully described in PCA Development Department Bulletin D 45, "Shear Tests of Continuous Girders" [4].

6. Creep and Shrinkage Studies

Two 66-ft. long continuous girders, similar to the one tested to destruction in stage (4), were subjected for approximately two years to sustained loading

which simulated dead load of the prototype. One of the girders was provided with a connection designed to resist reverse moments at the center support. Extensive measurements were made of support reactions, girder deflections, and steel and concrete strains. Periodically the continuity behavior of the girders was checked by loading them and measuring the support reactions.

At the end of two years the girders were loaded to destruction in the manner described in stage (4). The ultimate strength of the girders was not affected adversely by the creep and shrinkage effects, but from the observations made it was concluded that to ensure fully continuous behavior at service loads after an extended period of time means should be provided to resist reverse moments set up at the interior support sections due to creep deformation of the precast prestressed girders. This can be readily accomplished by the use of suitable details.

7. Repeated Loading

Earlier work in this experimental program demonstrated the capacity of this type of connection to resist static loads. This work was supplemented by a study of the behavior of a typical connection when subject to repeated loading. The specimens used simulated at half-scale that part of a girder which extends 20-ft. either side of the center support, as taken from the design study bridge. In these tests, the only variable considered was the maximum value of the pulsating load. The specimens were supported at the diaphragm, and loaded at their ends by Amsler pulsating load rams, as may be seen in Fig. 10. The connection was designed to have a static ultimate flexural strength 2.5 times the service load moment.

The number of applications of load necessary to cause failure for various values of the upper load limit are shown in Fig. 11. In all cases the lower load

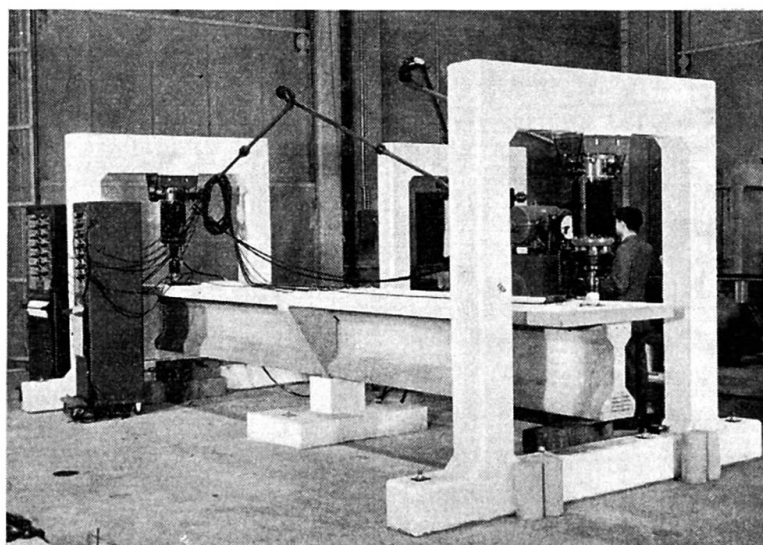

Fig. 10. Repeated Load Test of Connection between two Precast-Prestressed Girder Stubs.

limit was 0.28 times the service load moment. The failures were in every case due to fatigue failure of the continuity reinforcement. The bottom flanges of the girders remained sound despite the very high compressive stresses. It appears from these tests that repeated loading at service load level should not adversely affect the performance of this type of connection.

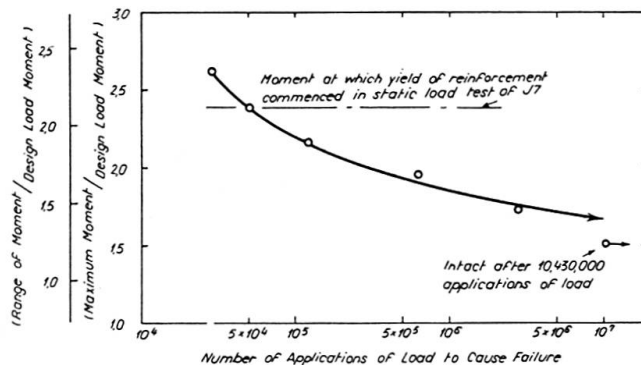

Fig. 11. Repeated Load Tests of Continuity Connection, Variation of Ultimate Moment with Number of Load Applications.

8. Reverse Bending

Continuous bridges of more than two spans, when subject to certain distributions of load, can develop positive moments at interior girder support sections. It has also been seen that positive moments can result from the effects of creep of the precast girders. Dynamic and static tests were therefore made on connections designed to resist this moment. A joint utilizing reinforcing bars embedded in the bottom flanges at the ends of the girders and welded to structural steel angle sections was found to be capable of developing the yield strength of the reinforcing bars and to have a satisfactory behavior as regards cracking.

9. Bridge Test

The final stage in this experimental program was a test of a complete half-scale model of the bridge considered in the design study. The testing of the bridge was carried out in two stages. Firstly, tests were carried out at service load level to check the continuity behavior of the structure, and also to investigate the extent of transverse distribution of concentrated loads applied to the bridge deck. A typical test is shown in Fig. 12. The 20,000-lb. dead weight loading block was placed at fifty locations on the bridge deck resting on a 12-in. square pad. Extensive measurements were made of deflections, strains, and reactions for each location of load. This type of test was carried out for three conditions of the deck slab: a) in its initial uncracked condition, b) after transverse cracks had been produced in the deck in the region of the center support, and c) after longitudinal cracks had been formed

in the deck slab between all girders. The distribution of deflections in the last test series, when the loading block was placed at midspan over various girders, is compared in Fig. 13 with the distribution of deflections calculated using the GUYON-MASSONNET [5, 6, 7] theory. It is seen that there is good agreement between the experimental points and the theoretical curve taking into account the torsional stiffness of the bridge members. The degrees of continuity measured in these three series of tests were 92.3%, 86.8%, and 91.2% of the

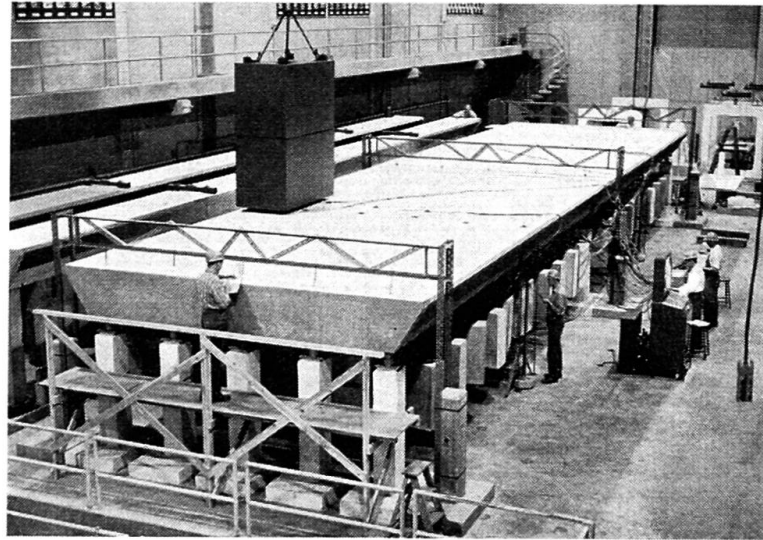

Fig. 12. Influence Surface Test of Half-Scale Highway Bridge.

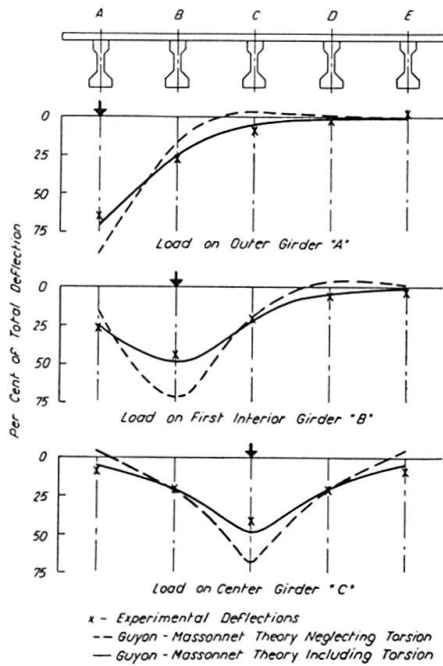

Fig. 13. Concentrated Load Tests — Series 3. Lateral Distribution of Deflections — Load at Midspan.

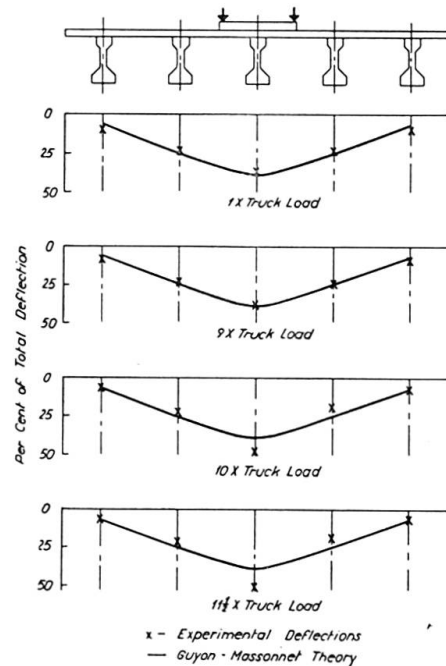

Fig. 14. Final Test, Lateral Distribution of Deflections.

theoretical continuity assuming constant stiffness of the structure over its entire length.

The second stage in the testing of the bridge involved a series of overload tests, culminating in a test to destruction by applying a group of four point loads centrally in one span. The grouping of loads used in this test was intended to simulate the grouping of loads in the equivalent military vehicle loading used in bridges on the Interstate Highway System. This loading system was chosen so that the lateral distribution of heavy loads could be examined, not to check the overall load factor for the structure. In these tests also, extensive measurements were made of strains, deflections, and reactions. The distribution of deflections for various levels of loading in the final test are shown in Fig. 14. The measured deflections are compared with the distribution of deflections calculated using the GUYON-MASSONNET theory including the effect of torsional stiffness. Excellent agreement was observed until the load reached 10 times the equivalent vehicle load, at which time a diagonal tension crack appeared in the slab around the loading heads. Further increase in load led to punching shear failure of the deck slab, which in turn resulted in a local failure of the precast girder below the punched-through zone, at a load of 11.5 times the equivalent vehicle load.

Concluding Remarks, Bridge Project

The soundness has been demonstrated, by extensive experimental investigation of that form of bridge construction in which continuity is created between precast prestressed girders by placing deformed bar reinforcement longitudinally in the deck slab across the intermediate piers. Results obtained during the tests are being studied to the end that design criteria may be evolved for the various aspects of the design of such a structure. The test program, and the conclusions drawn from it, are being reported in a series of Portland Cement Association Development Department Bulletins. The title of the series is, "Precast-Prestressed Concrete Bridges". Parts 1, 2, 3, and 4 have been published as Bulletins D 34 [1], D 35 [2], D 43 [3], and D 45 [4]. Other parts will be published in the near future.

Application to Building Construction

Continuous construction is fully as desirable in building construction as in bridge construction. A project has been initiated, therefore, to examine the applicability of this type of continuity connection to a construction consisting of precast prestressed double-tee members combined with a cast-in-place topping.

The first specimens tested consist of two short double-tee members joined together by a cast-in-place diaphragm around their abutting ends, and with

conventional deformed reinforcing bars over the joint in the cast-in-place topping. These specimens were supported under the diaphragm, and were loaded at each end. Specimens so far tested indicate that the conclusions drawn from the tests of the connections of I-shaped girders are equally applicable to connection between the double-tee type of member.

The continuity behavior of this form of construction at various levels of loading is also being investigated using specimens consisting of two 27-ft. spans continuous with 6-ft. tied down cantilevers at each of the outer ends. Conditions in the 27-ft. spans simulate those existing in the center two spans of a six span continuous system loaded over the two center spans only. Testing of these specimens is only now commencing. The variables to be investigated are the design support moment for a given total load to be carried by the system, and use of various degrees of prestress in the double-tee members. In all cases the continuous members will be designed to give a constant over-all load factor, by the adjustment of the midspan design moment according to the principles of limit design.

Application of this type of connection to building construction results in sounder and more economic structures than those made from precast concrete members which do not utilize continuity.

References

1. KAAR, P. H., KRIZ, L. B., and HOGNESTAD, E., "Precast-Prestressed Concrete Bridges, Part 1 — Pilot Tests of Continuous Girders". Portland Cement Association, Development Department Bulletin D 34.
2. HANSON, N. W., "Precast-Prestressed Concrete Bridges, Part 2 — Horizontal Shear Connections". Portland Cement Association, Development Department Bulletin D 35.
3. MATTOCK, A. H., and KAAR, P. H., "Precast-Prestressed Concrete Bridges, Part 3 — Further Tests of Continuous Girders". Portland Cement Association, Development Department Bulletin D 43.
4. MATTOCK, A. H., and KAAR, P. H., "Precast-Prestressed Concrete Bridges, Part 4 — Shear Tests of Continuous Girders". Portland Cement Association, Development Department Bulletin D 45.
5. GUYON, Y., «Calcul des ponts larges à poutres multiples solidarisées par des entretoises». Annales des Ponts et Chaussées. Paris 1946, September-October, pp. 553—612.
6. MASSONNET, C., «Méthode de calcul des ponts à poutres multiples tenant compte de leur résistance à la torsion». Publications, International Association for Bridge and Structural Engineering, Zurich 1950, Vol. 10, pp. 147—182.
7. MASSONNET, C., «Compléments à la méthode de calcul des ponts à poutres multiples». Offset Delporte, Mons.

Note: Since preparation of this paper was completed the following additional Bulletins have been published, which describe the final phases of the investigation.

8. MATTOCK, A. H., "Precast-Prestressed Concrete Bridges, Part 5 — Creep and Shrinkage Studies". Portland Cement Association, Development Department Bulletin D 46.
9. MATTOCK, A. H., and KAAR, P. H., "Precast-Prestressed Concrete Bridges, Part 6 — Test of a Half-Scale Highway Bridge Continuous Over Two Spans". Portland Cement Association, Development Department Bulletin D 51.

Summary

The Research and Development Laboratories of the Portland Cement Association have conducted a comprehensive laboratory investigation of a simple method of developing continuity for live loads in precast prestressed concrete bridge construction. The type of bridge selected for study includes precast I-shaped girders, pretensioned with straight 7-wire strands without the use of end blocks. Continuity from span to span is obtained by the use of diaphragms at the girder ends together with a situ-cast deck slab which contains deformed bar reinforcement to carry the moments at intermediate supports. Tests of individual girder-slab members included studies of continuity performance, horizontal shear, diagonal tension, flexural strength, creep and shrinkage effects, fatigue effects, and reverse bending. Finally, a complete two-span, two-lane bridge was constructed at half scale in the laboratory and was tested to failure.

The findings of the bridge project have constituted a starting point for application of the same principles to building construction. A similar laboratory study of rather broad scope is now under way to investigate composite construction and continuity in the assembling of precast prestressed building elements.

Résumé

Le Laboratoire de Recherche et Développement de l'Association des Ciments Portland a entrepris de vastes recherches ayant pour but de trouver une méthode simple permettant de réaliser la continuité, pour les charges utiles, dans des ponts constitués d'éléments préfabriqués et précontraints. Ces recherches ont porté sur un type de pont comprenant des poutres en forme de I, précontraintes par des câbles comportant sept fils rectilignes sans tête d'ancrage. De travée en travée, la continuité est obtenue à l'aide de diaphragmes disposés aux extrémités des poutres et par une dalle de tablier, coulée sur place et munie de fers d'armature profilés servant à la reprise du moment de flexion au droit des appuis intermédiaires. Les essais sur des «poutres-dalles» isolées comprenaient des recherches sur la continuité, les efforts rasants, les tensions principales, la résistance à la flexion, le retrait et le fluage, la résistance à la fatigue et l'influence d'une flexion de signe inverse. Finalement, un pont entier à deux travées et deux voies, exécuté à l'échelle 1 : 2, fut sollicité jusqu'à la rupture, en laboratoire.

Les résultats obtenus ont constitué le point de départ pour l'application des mêmes principes à la construction des bâtiments. Des recherches similaires de grande envergure sont actuellement entreprises afin d'étudier la réalisation de la liaison avec des éléments coulés sur place et de la continuité dans les assemblages entre éléments de bâtiments précontraints et préfabriqués.

Zusammenfassung

Das Forschungslaboratorium des Portland-Zementkonzerns hat umfassende Untersuchungen in seinen Laboratorien ausgeführt, um eine einfache Methode zur Herstellung der Durchlaufwirkung für die Nutzlast in vorfabrizierten, vorgespannten Konstruktionen zu entwickeln. Untersucht wurde ein Brückentyp, dessen I-förmige Hauptträger mit 7-drahtigen Litzen ohne Ankerköpfe vorgespannt waren. Zur Herstellung der Durchlaufwirkung dienten an den Trägerenden angeordnete Scheiben sowie eine mit normalen Betoneisen bewehrte Ortsbetonfahrbahn, deren Armierung die Momente über den Zwischenstützen aufzunehmen hatte. Die an den einzelnen Plattenbalken, bestehend aus Hauptträger und Ortsbetonfahrbahn, ausgeführten Versuche umfaßten die Untersuchungen über die Güte der Durchlaufwirkung, die horizontale Scherbeanspruchung, die Hauptspannungen, die Biegefestigkeit, das Schwinden und Kriechen, die Ermüdungsfestigkeit und den Einfluß positiver Momente über den Stützen. Schlußendlich wurde eine vollständige zweifeldrige, zweispurige Brücke im halben Maßstab im Labor aufgebaut und bis zum Bruch untersucht.

Die aus diesen Versuchen gezogenen Folgerungen erlaubten, die gleichen Konstruktionsgrundsätze auf Hochbauten anzuwenden. Eine umfangreiche entsprechende Untersuchung wird nun unternommen, um die Verbundwirkung mit Ortsbetonelementen und die Durchlaufwirkung in den Anschlüssen von vorfabrizierten, vorgespannten Hochbauelementen zu ermitteln.