

Plenary session 2: Structural contribution to natural disaster reduction

Objekttyp: **Group**

Zeitschrift: **IABSE congress report = Rapport du congrès AIPC = IVBH
Kongressbericht**

Band (Jahr): **14 (1992)**

PDF erstellt am: **12.07.2024**

Nutzungsbedingungen

Die ETH-Bibliothek ist Anbieterin der digitalisierten Zeitschriften. Sie besitzt keine Urheberrechte an den Inhalten der Zeitschriften. Die Rechte liegen in der Regel bei den Herausgebern.

Die auf der Plattform e-periodica veröffentlichten Dokumente stehen für nicht-kommerzielle Zwecke in Lehre und Forschung sowie für die private Nutzung frei zur Verfügung. Einzelne Dateien oder Ausdrucke aus diesem Angebot können zusammen mit diesen Nutzungsbedingungen und den korrekten Herkunftsbezeichnungen weitergegeben werden.

Das Veröffentlichen von Bildern in Print- und Online-Publikationen ist nur mit vorheriger Genehmigung der Rechteinhaber erlaubt. Die systematische Speicherung von Teilen des elektronischen Angebots auf anderen Servern bedarf ebenfalls des schriftlichen Einverständnisses der Rechteinhaber.

Haftungsausschluss

Alle Angaben erfolgen ohne Gewähr für Vollständigkeit oder Richtigkeit. Es wird keine Haftung übernommen für Schäden durch die Verwendung von Informationen aus diesem Online-Angebot oder durch das Fehlen von Informationen. Dies gilt auch für Inhalte Dritter, die über dieses Angebot zugänglich sind.



Plenary Session 2

Structural Contribution to Natural Disaster Reduction

Contribution du génie civil à la réduction des catastrophes naturelles

Beitrag des Bauwesens zur Verminderung von Naturkatastrophen

Organizer: Johan Blaauwendraad,
The Netherlands

Chairman — S.S. Chakrabarti
India

Leere Seite
Blank page
Page vide

Natural Disaster Reduction through Structural Quality

Réduction des catastrophes naturelles grâce à une meilleure qualité des structures

Verringerung von Naturgefahren durch bessere Bauqualität

Alan G. DAVENPORT
Professor
Univ. of Western Ontario
London, ON, Canada



Alan G. Davenport attained his B.A. and M.A. in Mechanical Sciences from Cambridge Univ. England, in 1954 and 1958 respectively, his M.A.Sc. in Civil Eng. from the Univ. of Toronto in 1957, and Ph.D. in Civil Eng. from the Univ. of Bristol in 1961. Appointed to the Eng. Faculty of the Univ. of Western Ontario, London, ON in 1961, he is now a Professor and founding Director of the Boundary Layer Wind Tunnel Laboratory since its establishment in 1965. He is currently Chairman of the Canadian Committee for the International Decade for Natural Disaster Reduction. Author of some 200 papers and recipient of a number of awards.

SUMMARY

The paper discusses the role the structural engineer can play in reducing natural disasters. The paper examines the strategies for disaster reduction and the obstacles that must be faced. The paper suggests that the control of quality must be a high priority in hazard resistant construction and suggests ways how this might be improved.

RÉSUMÉ

Cet article présente le rôle que peut jouer l'ingénieur civil dans la réduction des catastrophes naturelles et il examine les stratégies à envisager et les obstacles à surmonter pour y parvenir. Il envisage de donner un rôle prioritaire au contrôle de la qualité des constructions devant résister aux risques envisagés et il suggère des moyens pour l'atteindre.

ZUSAMMENFASSUNG

Es wird die Frage nach dem Beitrag des konstruktiv tätigen Bauingenieurs bei der Linderung von Naturkatastrophen aufgeworfen, nach Strategien des Vorgehens und zu erwartenden Hindernissen. Der Verfasser vertritt die These, dass der Qualitätssicherung beim Bau widerstandsfähiger Tragwerke hohe Priorität zukommen muss, und schlägt Wege zu deren Verbesserung vor.



THE PROSPECTS OF NATURAL DISASTER REDUCTION THROUGH IMPROVEMENTS OF STRUCTURAL QUALITY

1.0 INTRODUCTION

Over the past 20 years the costs of natural disasters have escalated significantly. The number of catastrophes, as defined by the reinsurance industry, has nearly quadrupled. The World Bank has similar estimates for the increase in the costs of post-disaster reconstruction. The losses to smaller nations are often well in excess of their GNP and their development is seriously impeded.

It is these concerns and the needless waste involved which has inspired the declaration of the 1990's as the International Decade for Natural Disaster Reduction. The goal of the Decade is to reduce the losses of life and property from disasters due to various natural hazards including earthquakes, wind storms, tsunamis, floods, landslides, volcanic eruptions, wild fires, grasshopper and locust infestation.

Natural disasters are not a new problem and in fact are as old as the hills. Human history and mythology is steeped in the dread of catastrophes as far back as biblical times. At some times in our history, peoples' responses have been fatalistic and disasters regarded as "Acts of God". In some quarters this is still the case. But fortunately this is not the only view. While the natural events themselves may be inevitable and will continue, the disasters which result must be regarded largely as "Acts of Mankind" or more exactly, the failure of mankind to take prudent action when collectively in possession of the knowledge to do so. We are, indeed, "masters of our destiny".

In our progress to civilization, the concern for natural disasters and the development of counter-measures has been a powerful and persistent incentive. In fact it has been contended that the capacity to deal with natural disasters has been and is a critical measure of the advancement of our civilization. To come through a severe natural disaster is a test of the technical capacity to mitigate the disaster, the social capacity to take appropriate humanitarian action as a community, and the political capacity to prepare for the emergency and maintain law and order at a time when there is panic and confusion.

These capacities are still a critical test of our own civilization. It is appropriate that it was the United Nations that passed the international resolution expressing our collective international intent to reduce natural disasters. It is not the intent, however, that the United Nations will take on the task by itself. It could not, the task is too great.

The task must be accomplished first through individual countries developing a national plan of action, and the internal institutions for emergency preparedness and disaster planning; second, through collective bilateral and multilateral



action, and third through the involvement of various sectors of society which have a stake in the outcome and ability to influence events. This last group includes the engineering profession, scientists, and technologist; the financial community, involving investors and insurers; as well as industry, and many important non-governmental organizations involved with emergency preparedness,

It is important to find where the weaknesses are in the way that we do things at present, find out what more can be done, and make changes. This is the challenge.

At present, the increasing threat of natural disasters, in spite of our increased knowledge is ominous. It is due to several causes. First, the increase in population and increase in size and numbers of large cities. This increases the "target area" for the disasters to strike. Second, because of the increasing scarcity of land, settlement is occurring on land such as coastal regions and floodplains, which are more vulnerable to natural disasters; and third because of the increasing cost and complexity of the infra-structure of modern life.

We are steadily becoming more vulnerable. The nature of the vulnerability is different in different countries. In India and Bangladesh, threatened by cyclones in the Bay of Bengal, there is the tragic threat to human life and the destruction of a fragile economy. In Tokyo or San Francisco, threatened by major earthquakes, there is not only a threat to life but also a different kind of danger from the economic shock wave which may follow as the insurance companies sell stocks to pay claims reaching, perhaps, many tens of billions of dollars.

Civil engineers, and in particular structural engineers, have a vitally important contribution to make in reducing these natural disasters. The evidence is that a major cause of earthquake and windstorm disasters is structural failure; the other major cause being inundation by the storm surge accompanying tropical cyclones, coastal erosion and river flooding. The skills and knowledge of civil engineers are key to the prevention of both these causes of disaster. Their skills are needed in the prevention of these disasters and reconstruction after the disaster has struck

There are indications that much more can be done.

This paper first discusses the general approaches to disaster mitigation and the role played by civil engineers. We illustrate the evolution of a natural disaster by considering the structural damage due to recent hurricanes in the Caribbean. We conclude with some suggestions for tasks for structural engineers to consider.



2.0 DISASTER MITIGATION: THE MAIN LINES OF DEFENCE

To appreciate the potential civil engineering role, it is worth considering the three main lines of defence in mitigating disasters - prevention, reduction of the impact, and recovery.

TABLE 1. MEASURES FOR DISASTER MITIGATION

***** major, ** significant, * minor**

<u>First Line of Defence: Prevention</u>	<u>Civil Engineering Involvement</u>
Hazard risk assessment	*** Estimation of extreme winds, seismicity and floods;
Planning	** definition of hazard prone areas;
Prevention	*** design of hazard resistant construction; inspection and maintenance; geotechnical site evaluation of slopes; shore protection and flood prediction.
<u>Second Line of Defence: Reduction of Impact</u>	
Emergency preparedness	
Warnings	* Flood, landslide warnings;
Dissemination	
Evacuation	
Shelter	* Evaluation of safety and design of shelters;
Search and Rescue	
<u>Third Line of Defence: Recovery</u>	
Relief (food, medical and other aid)	
Post-disaster assistance	** Re-establishing utilities; evaluation of damaged buildings and other facilities;
Reconstruction	*** Redesign, restoration and rehabilitation of damaged buildings and other facilities

The first line of defence is prevention. This involves assessing of the risk of the hazard occurring; planning and siting of settlements so that the effect of the



hazard is minimized; and construction of buildings, structures, and protective works (sea walls, dykes, etc.) which are hazard resistant.

The second line of defence is reducing the impact of the hazard. This includes the development of warning systems, the dissemination of the warnings to the public, evacuation and shelter, as well as search and rescue.

The third of defence is recovery. This embraces relief operations, post disaster assistance and ultimately reconstruction.

Clearly, the measures higher in the disaster-recovery cycle have greater leverage in reducing the potential disaster. However the humanitarian response following a disaster is such that more resources are usually given to measures lower down the list. The purpose of the International Decade for Natural Disaster Reduction is to reverse this trend, by putting greater emphasis on prevention, without jeopardizing relief and reconstruction.

Civil engineers and structural engineers have an important role in most phases of these defences but particularly in the prevention phase and the reconstruction. Table 1 indicates the degree of involvement.

3.0 HURRICANE GILBERT

The transformation of a natural hazard into a natural disaster is apparent from the following example of hurricane Gilbert. This storm was described as the "hurricane of the century" and was the most severe storm to strike Jamaica since Hurricane Charlie in 1954. The losses were over \$2.2 B, in excess of the annual GDP of the island.

Sustained wind speeds at 10 m height near the coast were estimated to be about 40 m/s with gusts up to about 60 m/s, similar to the "design speeds" in the codes for Jamaica. All regions of the island were affected. The influence of terrain roughness and topography would have modified these approach wind speeds at the coast where they would be higher on hill crests and lower in the lee of hills.

The damage (and its consequences) can be summarized as follows.

Roughly 130,000 or 25% of the houses suffered significant damage. These ranged from simple "chattel" houses, housing estates built through government agencies, and the larger more expensive houses particularly those on the hill crests surrounding Kingston. Without roofs, water damage from the torrential rains crippled the capacity of families to recover. Damage was mainly to roofing.



Significant damage was reported to ten hospitals. This left the community without the facilities to treat those injured in the storm, and they faced afterwards the replacement of the structure, supplies and costly medical equipment.

Schools, and churches and other buildings designated and used as refuges, were badly damaged even when people were sheltering in them. 500 of the 580 schools in the island were damaged or destroyed.

Other essential structures destroyed included communication towers and buildings. Early in the storm, the roof of the main international telephone exchange was damaged, the switching equipment drenched, and communications overseas were cut off. This confused reporting of conditions and delayed the despatch of relief and supplies.

Internally, communications were cut by the failure of the 300 ft. tower on St. Catherine's Peak carrying the main microwave repeaters for the island. Towers at the police headquarters in Kingston, and the military base at Newcastle were destroyed interfering with the essential military and police communications. Towers at most radio and television stations on the island were also damaged, preventing broadcast of warnings and bulletins.

The Mona Campus of the University of the West Indies lost roofs from the Administration buildings, the Law school, the Performing Arts Centre and the student residence. The losses included the Law and various library collections, valuable research results and a long delay in the academic year.

Utilities, such as power and water were interrupted for many days - weeks inland. Although the main high voltage distribution network on the island, carried on steel towers survived intact, 50% of the wooden utility poles were destroyed both by wind and fallen trees and branches. Water supply was interrupted in many regions, in one instance due to the collapse of a roof over a reservoir.

There was extensive damage to industrial buildings throughout the island. Principally these were older buildings but there were numerous examples of newer buildings as well. The loss of these structures had a direct impact on the productivity of the economy and jeopardised the income of the workers.

The tourist industry, the island's largest foreign currency earner, was seriously affected. Photographs in the foreign press of hotels without their roofs caused vacationers to switch their bookings.

Although damage to larger office buildings in down town Kingston was relatively light, there was extensive glass breakage, and water damage was consequently serious. One insurance company lost the records on its policyholders.



Losses to agriculture contributed significantly to the measure of the disaster. As well as very heavy crop damage - to bananas, citrus, sugar, coffee and coconut palms, there was widespread damage to storage sheds, and chicken houses (the occupants of which were decimated). Jamaicans who were accustomed to being self reliant for food, were suddenly dependent on imports.

The heavy rainfall which accompanied the storm washed out roads and bridges and once again compromised the efforts at relief and slowed down recovery.

The following conclusions can be made on the disaster due to hurricane Gilbert.

- The disaster was primarily due to the failure of buildings and disruptions in its aftermath.
- The intensity of the storm itself closely matched the design wind considered in the standards prepared for use in Jamaica (CUBIC and Jamaican Building Code). If buildings had been designed to withstand these winds with the appropriate safety factors, and built accordingly, very little damage might have occurred.
- The marginal costs of building to these standards would have been nominal.
- Most of the building failures appeared to be the result of inadequate quality control.
- There was evidently a lack of guidance and appropriate standards for roofing. This applied in particular to the thicknesses and fasteners needed for aluminium and galvanized steel sheet, and the use of adequate attachment of the rafters to the walls.

On the positive side there were examples of the proper functioning of well built structures.

- Most block masonry walls were reinforced. This prevented wall collapse even after the roof had gone and reduced fatalities. The practice was learnt in part over 50 years ago following a severe earthquake.
- "Hurricane straps" used to hold down the roof rafters to walls worked well when used.
- Traditional style, steep hipped roofs, with short eaves, planting beneath the sheeting performed noticeably better than flat, gabled roofs, with lattice and corrugated sheeting.



- A significant number of pre-engineered metal buildings erected throughout the island performed without significant damage. They were designed and built to the standards; the trades erecting the buildings were trained and inspection was thorough.

Other important factors which help the recovery included:

- excellent advanced weather warnings, giving time to bring in supplies and board up windows;
- relatively high insurance coverage (about 99% reinsured in hard currency) allowing early financing of repairs and;
- generous supply of foreign aid and funds for reconstruction.

The capability of buildings and structures to survive is also a key determinant in the severity of a earthquake disaster. This latter was illustrated in two earthquakes of comparable intensity at the site - Armenia and Loma Prieta. The loss of life, which was tens of thousands in the former case versus a little more than a hundred in the latter, reflected the general use of modern building codes in the design of structures in San Francisco.

The paramount question is how hazard resistant construction can be achieved more widely?

4.0 SOME OBSTACLES

To consider the obstacles to hazard resistant construction it is necessary to recognize that the construction process is awkward and often involves a number of people with separate responsibilities and influence on the outcome. They include the owner who will take responsibility for the use and maintenance of the structure once it is designed and built; the investor (owner, government, bank or aid agency) who wishes to see a return on his investment; the insurer, who protects the investor by insuring the structure against natural disaster; the design professional who contracts with the owner to design the structure; the contractor who builds it; the materials suppliers; and finally a government regulatory body that sets standards, prescribes a code of practice and inspects the construction for compliance with the code.

In most countries the "construction industry" tends to have a loosely knit, fragmented structure, particularly in developing countries.

Skills and trades are sometimes migrant, poorly trained and inexperienced in some "newer" technologies. Experienced job site superintendents are hard to find,



preferring to "retire" to more regular occupations instead of the "roller-coaster" of the construction industry cycles. Unlike the manufacturing industry, construction deals mostly with "one off" products, and instead of the controlled environment of a factory, contends with variable site and weather conditions.

Bidding practices are competitive and financial risks are high. There are incentives to cut corners and disincentives to careful inspection of workmanship.

Regulatory practices concerning disaster resistant construction have important deficiencies in most jurisdictions. In developing countries codes and standards pose problems. Often they are hard to get, reflect conditions in countries which are quite remote, and are unenforced. Loading and materials standards are sometimes mismatched. "New" technologies (roofing materials, for example, introduced for economic reasons to replace "traditional" approaches) are sometimes marketed without adequate technical information.

Many countries in which disasters occur are poorer countries. Owners may be very short of funds and resources and may not be particularly concerned about a threat which last occurred a generation ago. This short term perspective also prevails amongst more sophisticated owners and investors. There are hopeful signs that this is changing.

In many communities the perception of disasters is accompanied by a fatalism which inhibits special efforts to confront the hazard; there may be gaps in understanding about what can be done.

When funds are stretched to the limit, maintenance becomes a low priority. A recent practice in some UNDP construction projects to incorporate a special maintenance fund in the initial capital grant may be a useful approach. At the same time there has been a reluctance for aid agencies to interfere in decisions which are considered to be prerogative of the country receiving the aid. Their influence on hazard resistance has similarly been restrained.

While the owner and investor protect their investment through insurance, local insurance companies usually reinsure the bulk of their disaster coverage overseas. This spreads the risk of these infrequent events and provides for hard currency payments when and if the losses arise. Because of this indirect relationship between the insured party and the reinsurer, the latter has very little direct knowledge of any structure or its hazard resistance. The local insurer, carrying a small fraction of the risk, tends to lump the risk with other hazards such as fire.

Historically the insurance industry has had a strong influence on the standards of marine safety, with shipping and off-shore oil construction. However the influence of insurance in improving the disaster resistance of on-shore construction has been slight. Proposals for premium incentives for disaster rated construction are



however now under study. This is timely in view of recent bad disaster insurance experience (a fivefold increase in the number of "catastrophic" events in the past twenty years) and the reluctance of reinsurance companies to provide coverage.

5.0 WHAT STRUCTURAL ENGINEERS CAN DO?

The following are a number of actions which the structural engineering profession is particularly well qualified to take.

5.1 Risk Assessment

- a. Develop regional risk maps. Risk mapping should give the magnitude of key structural loads such as earthquake peak ground acceleration and maximum wind speed (or velocity pressure), for specific levels of annual risk. Such procedures are now established for most important structural loads. In some cases the basic meteorological or other geophysical data may be lacking. In these cases synthetic methods may be assumed to estimate the data that is lacking. One example of the latter is the "Monte Carlo" simulation of hurricane winds.
- b. Develop maps of local site hazards and allow for these hazards in assessing the loads. These include soft soils which selectively amplify certain frequency bands in the earthquake shock spectrum at bedrock; land subject to flooding; and topography which causes "speed-up" of the wind, near hill crests.
- c. In particular 'balanced risk' approaches to safety for strategically important structures such as hospitals, major bridges, etc. should be encouraged. In this the risk levels of the design loads are chosen so that the marginal costs of increasing the resistance of the structure are balanced by the decrease in the expected costs of failure.

5.2 Siting and planning

Use this information on hazard risks in the siting of structures and settlements. The information of risks should if possible be integrated into the assessment of insurance risks.



5.3 Hazard Resistant Construction

A major reason for the failure to achieve adequate hazard resistant construction has been found to be inadequate quality control in the construction process. Hazard resistant construction should therefore be thought of as part of the overall approach to quality control in the industry. The steps that should be taken to assist in achieving this are:

- a. Within selected jurisdictions, investigate the quality control measures available to the construction industry together with a critique of their effectiveness. The study should address such issues as materials supply and distribution, design and specification processes, construction, training, regulation and inspection. These questions should be asked at the level of the housing owner/builder, design and/or construction by national companies and international companies. The enquiry should evaluate the influence on the quality of construction of insurance, financial institutions, aid agencies, government, industry as well as the public.
- b. As a result of this investigation recommendations for action should be developed which will improve hazard resistance as part of a total quality approach to construction. The following interlocking objectives should be part of this broader approach to hazard resistance:
 - to improve the awareness of industry, the public and government of the value of hazard resistant construction and its proper maintenance;
 - to improve the performance of new and existing structures providing essential services during a disaster; and
 - to improve the job quality in construction; and
 - to improve the productivity and profitability of the construction industry.
- c. Increase the awareness of the importance of hazard resistant construction in key sectors of society which can influence the quality of the construction process. Within the scope of these objectives, several initiatives might be productive.
 - Make the aid agencies, banking and insurance industries aware of the importance of hazard resistance and study ways for their direct involvement in the quality assurance process;
 - Make various industries - the tourist and manufacturing industries in particular - aware of the cost-benefit advantage of hazard resistant construction so that they will act as pace setters in encouraging other sectors to follow.



- Make government aware of the importance of ensuring the serviceability of essential service buildings and structures during and after the disaster. Ensure that such buildings reflect a "balanced risk" approach to safety in which the safety factor reflects the uncertainties and the strategic importance of the building.
 - Consider the appointment of a "hazard resistance auditor" to verify and assist with hazard resistant construction. This person would be available to government in certifying public buildings for hazard resistance, the insurance companies and to individual investors.
- d. A number of technical issues deserve detailed study. The following is a selection:
- Adaptation of traditional designs which functioned well to current techniques. One example is the use of hip roofs. These roofs are traditional in some areas and can carry over 50% more wind load than a gable roof with the same amount of material.
 - The strengthening of old buildings through the use of "strong materials" and other means.
 - The development of procedures and criteria for the assessment of the hazard resistance of existing buildings and structures, including the certification of disaster shelters.
 - Incentive mechanisms for use by the insurance industry to raise the hazard resistance of construction.
 - Approaches for industry to include disaster resistance of buildings as part of the overall plant safety.
 - The development of user friendly codes and standards which foster the use of both new and traditional methods.
 - Establishment of better plans for reconstruction which avoid the repetition of previous defects.
 - Expansion of the engineering study of collective disasters, involving many structures, as opposed to the more usual concern for individual structures.

To achieve a significant reduction in natural disasters in accordance with the IDNDR, civil engineers should be prepared to take a leadership role particularly in improving hazard resistant construction as well as the protection against floods and landslides.

A Total Quality Control approach should be taken to the construction industry in order to improve the effectiveness of the industry and the delivery of hazard resistant construction.

River Training Works on Indian Bridges

Ouvrages de régulation des rivières à proximité des ponts en Inde

Flussregulierung zur Sicherung indischer Brücken

Ninan KOSHI

Add. Dir. Gen. (Bridges)
Ministry of Surface Transp.
New Delhi, India



Ninan Koshi, born 1936, B.Sc (Eng.) from Kerala University with 33 years of experience in the highway sector; presently working as Additional Director General (Bridges) in the Ministry of Surface Transport (Roads Wing), New Delhi – as Head of Bridges Directorate; Secretary, Indian Roads Congress & Chairman, Indian National Group of IABSE. He was also Chairman Organising Committee of 14th IABSE Congress.

SUMMARY

India's mightiest rivers have unusually large widths with meandering tendencies and absence of stable banks, posing enormous problems in siting of bridges across them and protecting the approaches from river attack. A solution has been found by constricting the width of flow of the river by providing artificial earthen banks suitably armoured. The paper discusses various aspects of planning, design and construction of these river training works along with some case studies.

RESUME

Les fleuves de l'Inde sont souvent imposants et extrêmement larges. En l'absence de rives stables, ils auraient tendance à quitter leurs lits. Il en résulte des problèmes énormes pour l'implantation de ponts et pour leur protection. Une solution consiste à contrôler la largeur du courant en réalisant des rives artificielles en terre, efficacement renforcées. L'article traite divers aspects de la conception, du projet et de la construction de ces ouvrages de régulation des rivières, à l'aide de quelques exemples.

ZUSAMMENFASSUNG

Wegen ihrer ungewöhnlichen Breite und Neigung zum Mäandrieren ausserhalb fester Ufer stellen die mächtigen, indischen Ströme enorme Probleme bei der Wahl von Brückenstandorten und dem Schutz der Zufahrten. Eine Lösung wurde in künstlichen, bewehrten Dämmen gefunden, die den Flusslauf eingrenzen. Der Beitrag behandelt einige Aspekte aus Planung, Entwurf und Bau solcher Regulierungsbauwerke anhand von Fallbeispielen.



1. INTRODUCTION

1.1 The geographical disposition of the Indian sub-continent is unique. It is bounded by the high mountains of Himalayas in the North and the peninsula region in the South. It has staggeringly diverse geographical features in terms of terrain, soil and climatic conditions and consequently there are wide variations in the behaviour of its rivers also. While in the southern part of India, known as Deccan Plateau, the rivers have carved deep channels through predominantly rocky strata and stable banks, the rivers in the northern part of the country known as Indo-Gangetic plain flow through deep alluvial deposits and have undefined and unstable banks in most regions. Also, these rivers have meandering behaviour, swinging several kilometres from one side to the other, over the years. The maximum width over which the river meanders during high floods is known as the 'khadir' width of the river. An unique example of such meandering behaviour is that of Kosi river which has shifted its course by about 112 Kms. between the years 1736 to 1964. In this movement, about 7700 sq. km. of land in India and approximately 1300 sq. km. in Nepal have been laid waste as a result of sand deposition. For such rivers in the Indo-Gangetic plain, where the width of 'khadir' is much more than the active channel, bridges would have to be constructed across the full 'khadir' width as otherwise there is a danger of these being outflanked. The cost of such long bridges would be prohibitive and, therefore, it becomes necessary to constrict the width of the river by training it.

1.2 In the early days, Indian engineers used the method of providing retired embankments or a series of spurs along the banks on the upstream of the bridge site to train the alluvial rivers. These, however, did not prove to be effective because the spurs attracted eddies and got damaged in high floods, entailing high maintenance cost. An improvement on the system of providing spurs was tried by provision of a pair of long parabolic earth embankments with a comb of spurs running out at right angles. This also proved to be inadequate and expensive for maintenance. Further improvement in river training work was made by constricting the width of the river by providing a pair of embankments, called guide bunds, so that the river flow could be made axial through the bridge. The provision of guide bunds in lieu of spurs proved to be successful and was a landmark in the field of river control and training for construction of bridges. Since then construction of bridges across alluvial rivers in India are accompanied with river control and training measures by providing guide bunds as developed by Bell and improved upon by Spring. The system has proved to be technically sound and cost effective

2. GUIDE BUNDS

2.1 Guide bunds may be defined as artificial earthen embankments constructed in the river bed whose main functions are firstly to train the river and induce it to flow axially



through the constricted width of the bridge and secondly to protect the approach embankments from river attack. Guidelines for fixing the salient features and configuration of the guide bund system (Figure 1) required for efficient training of the river have been established and are as follows:

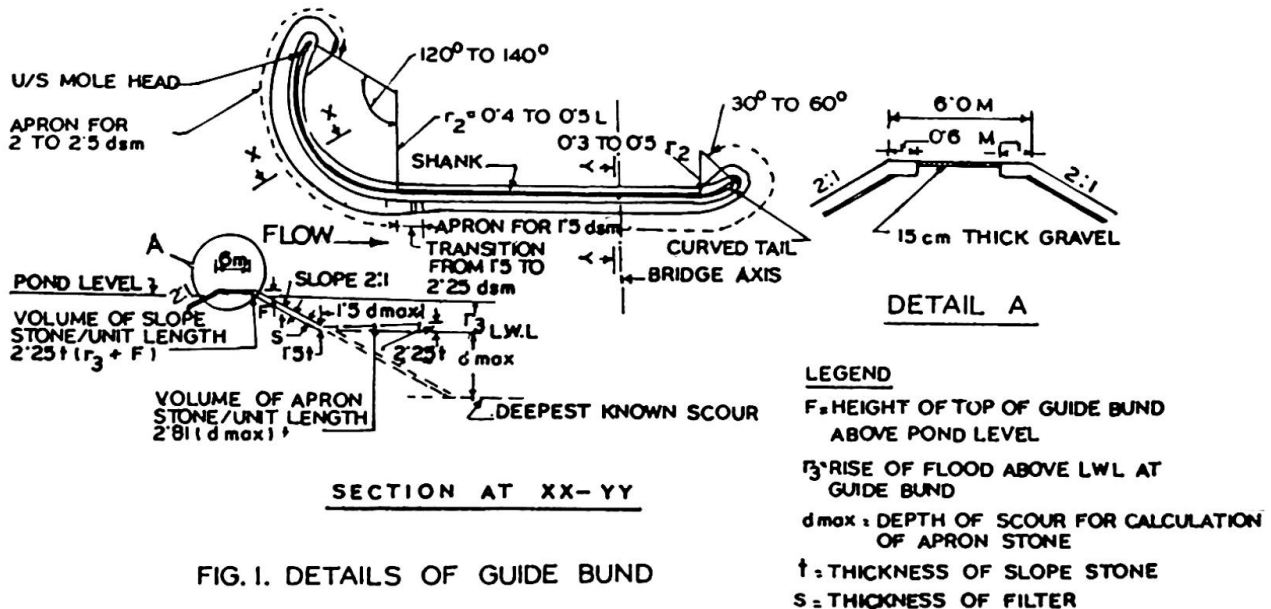

FIG.1. DETAILS OF GUIDE BUND

2.2 Constriction of width of river: This is decided on the basis of stable channel flow condition, known as regime flow condition, which can carry the maximum discharge of the river. Lacey made observations on several alluvial rivers in India and suggested that the regime width at the highest flood level depends on the discharge and the angle of internal friction of the bed material. He gave an empirical formula for regime width W as:

$$W = C \sqrt{Q}$$

Where W = Regime width in metres

Q = maximum discharge in m^3/sec .

C = A constant, usually taken as 4.8 for regime channels but varying from 4.5 to 6.3 depending upon local conditions of channel flow.

This formula has been found to give quite satisfactory results.

The clear waterway at HFL (High Flood Level) between the guide bunds is fixed as at least equal to Lacey's regime width (W). The constriction ratio may be defined as Total khadir width at bridge site divided by the Regime width or actual waterway provided.

The total length of the bridge (L) is fixed as clear waterway plus the obstructions due to piers.

2.3 Length of Guide Bunds on upstream (u/s) side: The length of guide bunds has to be fixed from two important considerations,



namely, the maximum obliquity of the current and permissible limit of embayment of the main channel of the river near the approach embankment behind the guide bund (Figure 2). It is generally fixed on the basis of the radius of the sharpest loop, which the river is capable of taking as shown by the data of the acute loops formed by the river in the past.

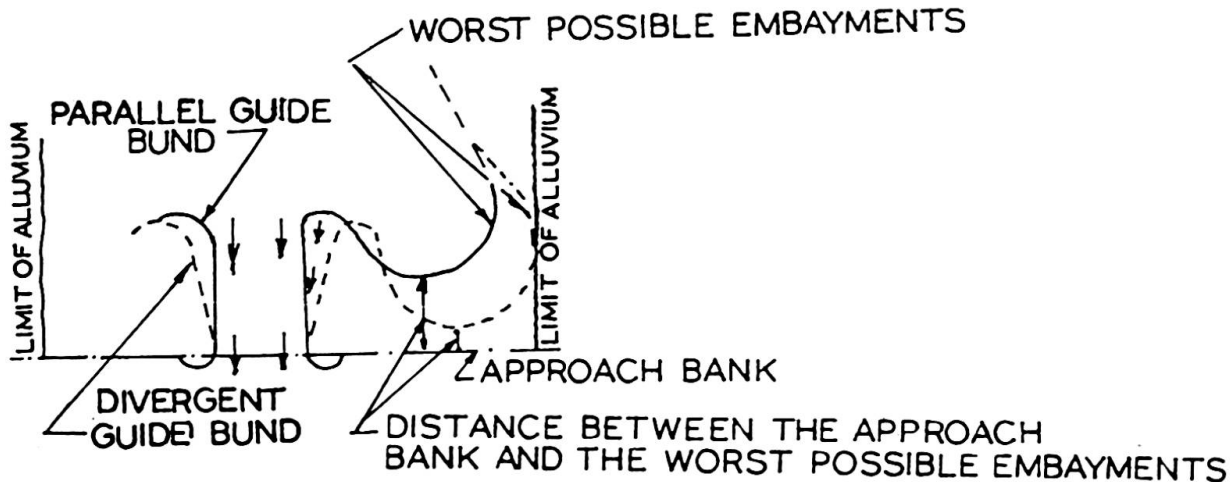

FIG. 2. EMBAYMENT

If survey plans do not indicate the presence of the sharpest loops it may be derived from a mathematical model. After having determined the radius of the sharpest loop the single or double loops are laid out on a survey plan showing the alignment of the approach embankment and high banks. It is ensured that the distance between the anticipated sharpest loop and approach embankment is not less than $L/3$ where L is the length of the bridge. The upstream length of the guide bund is usually kept as $1.0L$ to $1.5L$. Guide bunds are generally effective in protecting the approach banks beyond the abutments on either side for a length upto 3 times the length of the guide bunds. Where the constriction is large and the length of the approach banks are greater than three times the length of guide bunds, additional training/protective measures are required to be taken.

2.4 Length of Guide Bund on downstream (d/s) side: On the downstream side of the bridge, the river tries to fan out to regain its natural width. Here the function of the guide bund is to ensure that the river does not attack the approach embankment in the process of regaining its normal width. A length of $0.2L$ for the downstream portion of the bund is generally found to be satisfactory.

2.5 Radius and angle of sweep of u/s curved mole head

The radius of curvature of upstream mole head should be such as not to cause intense eddies which may be formed due to constriction of flow. The greater the radius and flatter the curve the less is the possibility of eddy formation. This, however, increases the cost. For proper functioning of the guide bund, radius of upstream mole head is generally kept as 0.4 to 0.5 times the length of the bridge (L). It is usually kept between 150 m. to 600 m. The angle of sweep of the upstream mole head is generally between 120° to 140° .



2.6 Radius and angle of sweep of d/s curved tail: Radius of curvature is generally kept as 0.3 to 0.5 times the radius of upstream mole head. Angle of sweep varies from 30° to 60°.

2.7 Top Width: The top width is generally kept as 6 m. to permit passage of vehicles for carriage of materials and inspection.

2.8 Free Board: The free board is measured from the pond level behind the guide bund after taking into account the afflux, kinetic energy head and water slope. The minimum free board is generally kept as 1.5 m to 1.8m.

2.9 Side Slope: Side slope of guide bund is generally determined from consideration of stability of the embankment and hydraulic gradient. Generally a side slope of 2(H):1(V) is considered appropriate for predominantly cohesionless materials.

2.10 Slope Protection: The river side slope is protected against erosion by pitching with stones/concrete slabs. The pitching is extended upto the top of the guide bund and tucked in for a width of atleast 0.6m at the top.

2.11 Rear Slopes of Guide Bunds: Rear slopes are also protected against wave splash by provision of 0.3-0.6 m thick cover of clayey or silty earth and turfing. Where moderate to heavy wave action is expected, stone pitching is laid upto a height of 1 m above the rear pond level.

2.12 Pitching on the river side: For the design of pitching on the river side, the factors to be taken into consideration are size/weight of the individual stone, its shape and gradation and thickness and type of filter underneath. The predominant flow characteristic which affects the stability of the pitching is velocity along the guide bund. Other factors like obliquity of flow, eddy action and waves are indeterminate and may be accounted for by providing adequate margin of safety.

2.12.1 The size of stones required on the sloping face of the guide bunds to withstand erosive action of flow may be mathematically worked out from the following equation:

$$d = Kv^2$$

Where

K=a constant, usually taken as 0.0282 for a slope of 2:1 and 0.0216 for a slope of 3:1

d=mean diameter of stone in metres

v=mean design velocity in metre/sec.

However, no stone weighing less than 40 kg. is used in order to prevent stones being carried away by river current. Where the required size of stones are not economically available, cement concrete blocks or stones in wire crates are used.

2.12.2 The thickness of pitching (t) in metres is determined from the following formula:

$$t = 0.06Q^{1/3}$$

t=0.06Q

Where Q= design discharge in m³/sec.



The thickness of stone pitching is subject to an upper limit of 1.0 m and a lower limit of 0.3 m.

2.12.3 Quarry stone is preferable to round boulders as the latter roll off easily. Angular stones are preferred as they fit into each other and have good inter-locking characteristics.

2.12.4 The stones for pitching are hand placed with the principal bedding plane normal to the slope. The pattern of laying is such that the joints are broken and voids are kept to a minimum by packing with spalls.

2.13 Filter: Filter is provided just below the stone pitching and generally consists of gravel, stone over burnt brick ballast or coarse sand. Provision of filter is necessary to prevent the escape of underlying base material of embankment through the voids of stone pitching/cement concrete blocks as well as to allow free movement of water without creating any uplift head on the pitching when subjected to attack of flowing water and wave action. In order to achieve this requirement, the following criteria are adopted to fix the size of filter material:

$$\frac{D_{15}(\text{Filter})}{D_{85}(\text{Base})} < 5$$

$$4 < \frac{D_{15}(\text{Filter})}{D_{15}(\text{Base})} < 20$$

$$\frac{D_{50}(\text{Filter})}{D_{50}(\text{Base})} < 25$$

Where D 15 is the size of that sieve which allows 15 percent by weight of the filter material to pass through it, D 50 and D 85 have similar meaning. The filter is compacted firmly. The thickness of filter is generally of the order of 150 to 200 mm.

2.14 Launching Apron

Launching apron is provided to protect the bund from the scouring action of the river. It is formed as a flexible pitching of the river bed, generally placed at low water level (LWL) in continuation of the slope pitching. The stone in the apron is designed to launch along the slope of the expected scour hole so as to provide a strong layer that may prevent further scouring of river bed material and undermining of the guide bund. The apron, when fully launched, is assumed to take a slope of 2(H):1(V) in case of loose boulders or stones and 1.5(H):1(V) in the case of cement concrete blocks or stones in wire crates. The size and shape of apron and the size of stone depends upon the depth of expected scour.

The extent of scour at different portions of the guide bund are adopted as under:

<u>Location</u>	<u>Maximum scour depth to be adopted</u>
Upstream curved mole head of guide bund	2 to 2.5 dsm
Straight reach of guide bund including tail of the downstream of guide bund.	1.5 dsm



where, d_{sm} is the mean depth of scour measured below highest flood level (HFL) .

2.14.1 Width of launching apron generally kept as equal to $1.5 d_{max}$ where d_{max} is the maximum anticipated scour depth in metres below low water level. The thickness of launching apron at inner and outer ends are kept as $1.5 t$ and $2.25 t$ respectively as shown in Figure 1, where t is the thickness of slope pitching.

2.14.2 It may be mentioned that an apron may fail to provide protection to the guide bund if the river bed contains high percentage of silt or clay or where the angle of repose of the bed material is steeper than that of stone as in such a case the apron may not launch properly.

2.15 General considerations

2.15.1 Usually guide bunds are constructed in pairs to guide the river flow between them. Their relative disposition could be parallel, divergent or convergent, depending on river behaviour at the location. (Fig.3)

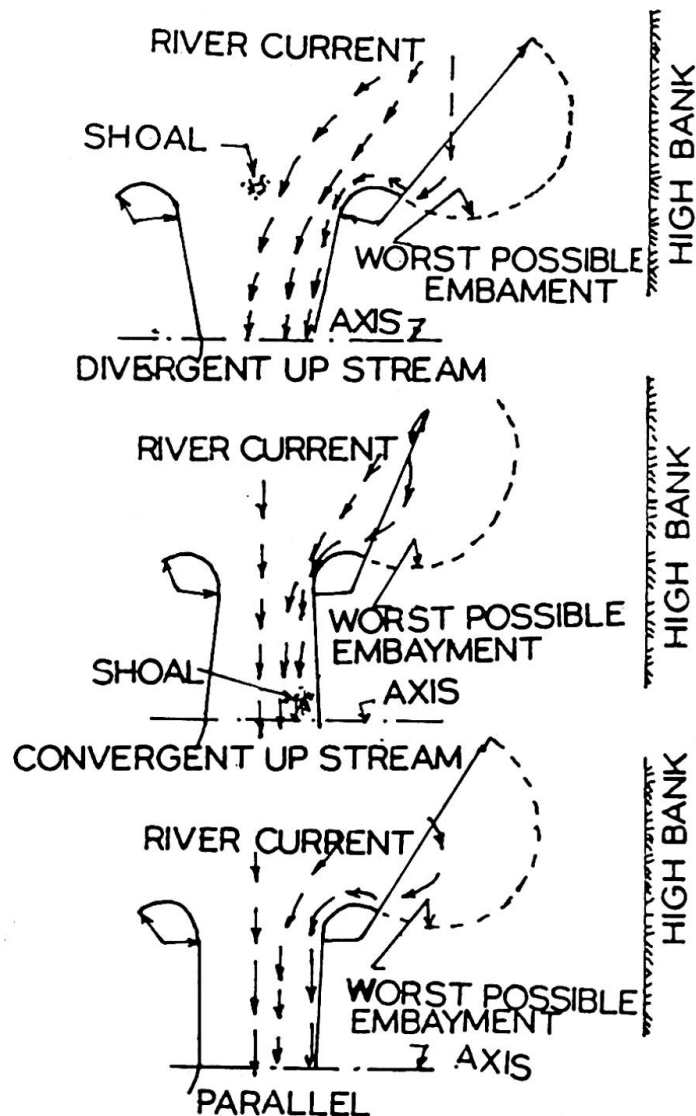

FIG. 3. DIFFERENT FORMS GUIDE BUNDS



2.15.2 Parallel guide bunds with suitable curved heads have been found to give uniform flow from the head of the guide bund to the axis of the bridge and so these are generally preferred.

2.15.3 Divergent guide bunds exercise an attracting influence on flow and they are used where the river has formed a loop and the approaching flow is oblique. However, they have a tendency of shoal formation at centre due to larger waterway between the downstream curved heads. They require a longer length in comparison to parallel guide bunds for the same degree of protection to approach embankment.

2.15.4 Convergent guide bunds have a disadvantage of excessive attack and heavy scour at the head and shoaling all along the shank rendering the end bays inactive. These are to be avoided as far as possible.

2.15.5 At certain locations, it may be possible to obtain a firm and stable bank on one side. In such cases only one guide bund on the other side needs to be provided. Obviously the cost of river training is reduced in such cases. This factor influences site selection of bridges, wherein the possibility of having a firm and stable bank in the vicinity of the site is a definite advantage.

2.15.6 Actual siting of a guide bund, however, requires a great deal of understanding of river behaviour. For this, river flow data is required to be studied to find out the most stable section in which the river has been flowing over a number of years. Based on physical site survey and the hydraulic behaviour of the river and the guidelines for the design, as mentioned above, a tentative design of guide bunds and their locations are fixed. Invariably, these are then tested in a model for their performance. We have a number of institutions, where facility for model testing on river behaviour is available. The flow pattern through the guide bund at different stages of discharge is studied in the model. It may be mentioned that in alluvial rivers, directions of river flow may sometime change at lower stages of discharge due to formation of shoals etc. but at design discharge level, flow may be parallel to the guide bund.

2.15.7 The configuration of the bund or the location may have to be slightly modified during model tests so that the flow is more or less axial and uniform between the guide bunds at all stages of discharge. The final configuration as confirmed from the model tests is adopted for execution.

3. CASE STUDIES:

3.1 Brahmaputra bridge near Tezpur

3.1.1 Planning & Design: Bridging Brahmaputra river, one of the major rivers of India has remained a real challenge to engineers especially on account of its hydrology and braided flow pattern. The river has defined banks only in its upper reaches i.e. in Tibet. Once it enters India it flows as a moving ocean from May to October, having flood plain width of 14 to 18 Kms. at most locations. The river carrying an annual runoff of 3,81,000,000,000 cum. also has a high silt load of approximately 0.102% transporting nearly 400 million tons of silt every year, causing wide ranging changes in the flow pattern.

Near Tezpur the river has a khadir width of approximately 5 kms. but the flood spill water extends far beyond this. The river is controlled on the north by Bhomoraguri hill and has a major tributary meeting it about 5 Kms. upstream on the north. These features have resulted in migration of the river to the south and there has been an active channel on the south side during the floods. Considering the facts that (a) any development in south channel may cause severe erosion of the south marginal bund and the river might outflank the bridge (b) large width may result in formation of shoals/islands at the bridge axis, and (c) development of concentration of flow in some bays may cause excessive scour, it was decided to construct a major guide bund on the south side. (Refer Fig. 4)

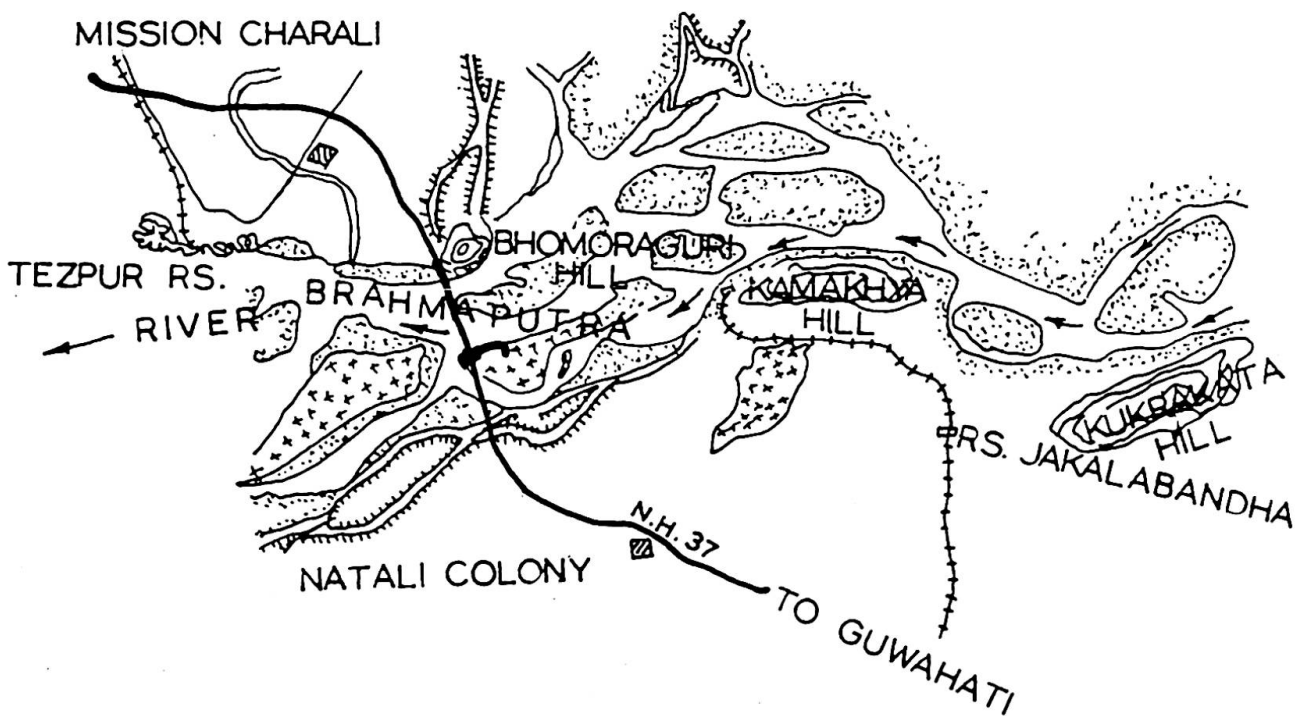

FIG. 4. LOCATION PLAN OF TEZPUR BRIDGE



This guide bund being the first on river Brahmaputra needed extensive studies for understanding its impact over the existing marginal bunds, road approach to the bridge and concentration of discharge, if any, for design of bridge foundations and most important of all, its impact over river flow condition with special reference to Tezpur town on the downstream.

Hydraulic model studies were carried out by U.P. Irrigation Research Institute, Roorkee. For the model studies, about 25 Km on upstream side and 10 Km on downstream side were surveyed in detail in respect of river cross sections, presence of firm points etc. Initially seven proposals with different alternatives of location, length and angle of guide bund were tested in the model and subsequently during the currency of work, additional model studies were required to be carried out due to changes in the river geometry.

Technical features of guide bund as constructed are as detailed below:(Also ref. Figure 5)

Discharge:	92,278m ³ /Sec.
Max. Velocity:	4 m/Sec.
Type	Elliptical with $\frac{x^2}{(1200)^2} + \frac{y^2}{(560)^2} = 1$ equation
Length	2000 m
Max. Scour depth below LWL	
(a) at the u/s shank	36.24 m
(b) at the mole head	52.27 m
Apron Width	
(a) at the u/s shank	54.50 m
(b) at the mole head	78.50 m
Apron material	Man size boulder (40-60 Kg.) placed in GI wire crates.
Apron thickness	Approx 3 m.
Slope pitching	1.5 m thick with 0.3 m of filter medium
Side slopes	River side 1:2.5 rear side 1:3
Top width	9.0 m.

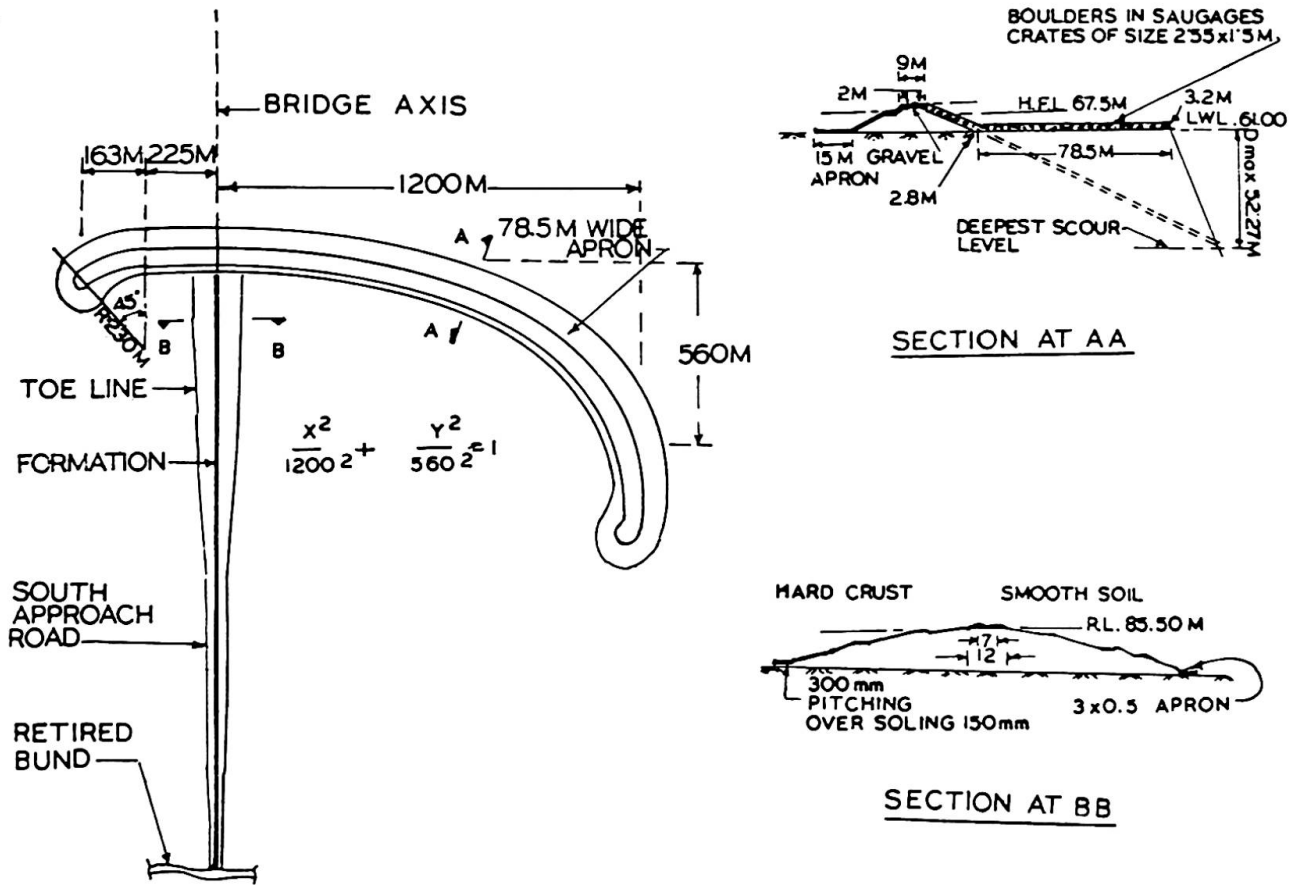

FIG. 5. GUIDE BUND DETAILS OF TEZPUR BRIDGE.

Since the khadir is very wide length of guide bund fixed according to the criteria does not provide enough protection to the approach embankment. It has been observed that the approach embankment is attacked by a single or double loop formation between the khadir edge and the guide bund (Fig. 6). In view of this it was necessary to study the river geometry on the upstream side particularly in the vicinity of the hillock or permanent point in the left bank and also take into account the radius of the worst embayment for deciding the length of guide bund.

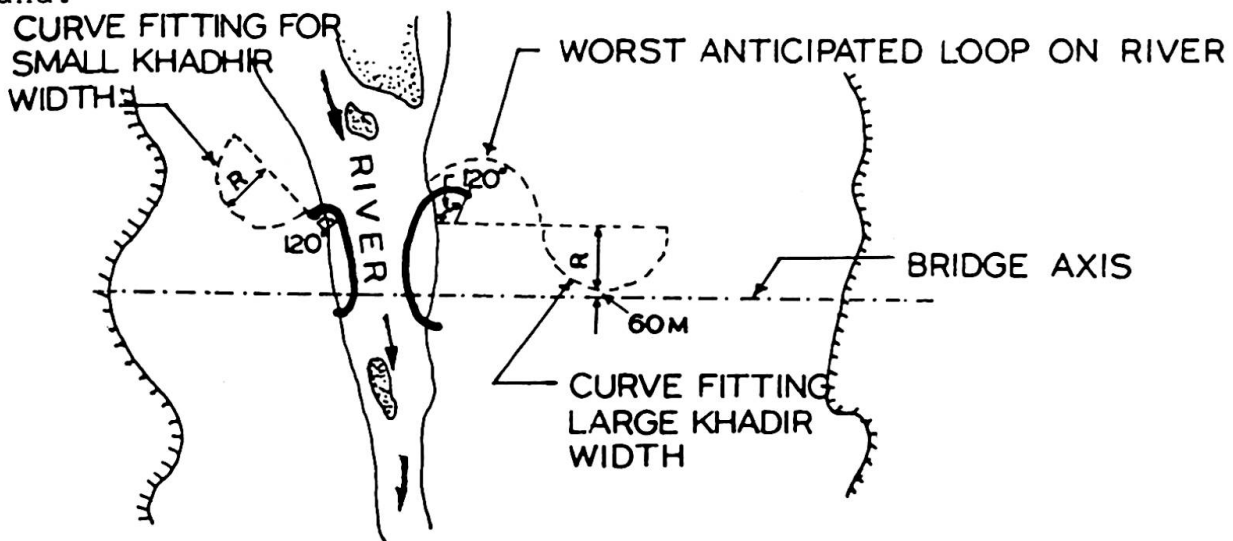

FIG. 6. DESIGN OF GUIDE BUND FROM LOOP CONSIDERATION



The road approach length 1.7 Km lies in the river khadir and has a risk of river forming embayment after leaving the tail end of the guide bund thereby, endangering the approach bank. Therefore, a series of boulder spurs were provided which helped in keeping the river course away from the approach bank.

3.1.2 Construction

Construction of guide bund and approach in river khadir requires detailed planning and construction strategy as the bulk of the work has to be completed in a short time i.e before floods set in. This problem gets further compounded in the case of Brahmaputra river where working period is restricted between November to April. Tezpur guide bund involved execution of about 1.9 million cum. of earthwork and 0.75 million cum. of stone work. Completion upto safe level which is HFL plus free board, required completion of 80% of earthwork and 95% of boulder work in 4½ months. This necessitated very high level of mechanisation. Some of the landmarks of construction were:

- it took 3 years to collect 0.75 million cum of boulders from hill face quarries and just 110 days to lay them in crates, pitching etc.
- average daily progress of earthwork was 12000 cum and of boulders 7000 cum respectively.
- nearly 12 Km of haul roads were developed for movement of earth-moving equipments.

Construction of guide bund became more difficult on account of development of active south channel. A series of river training works like permeable spurs etc. had to be provided to reduce the discharge in this channel. In spite of these works it was required to close the channel in the month of November for carrying across the construction equipment.

Guide bund and approach has been provided with a well designed drainage arrangement and sufficient stock of reserve boulders has been kept at site to meet any emergency. During the monsoon regular patrolling is done to assess any damage and immediate measures are taken to rectify the same. So far behaviour of guide bund, development of embayment etc. has remained in conformity with the model study results and is expected to remain the same in future too.

3.2 Brahmaputra Bridge at Jogighopa

3.2.1 From hydraulic constructions, the river is stable at Jogighopa due to presence of two hills namely Jogighopa on the

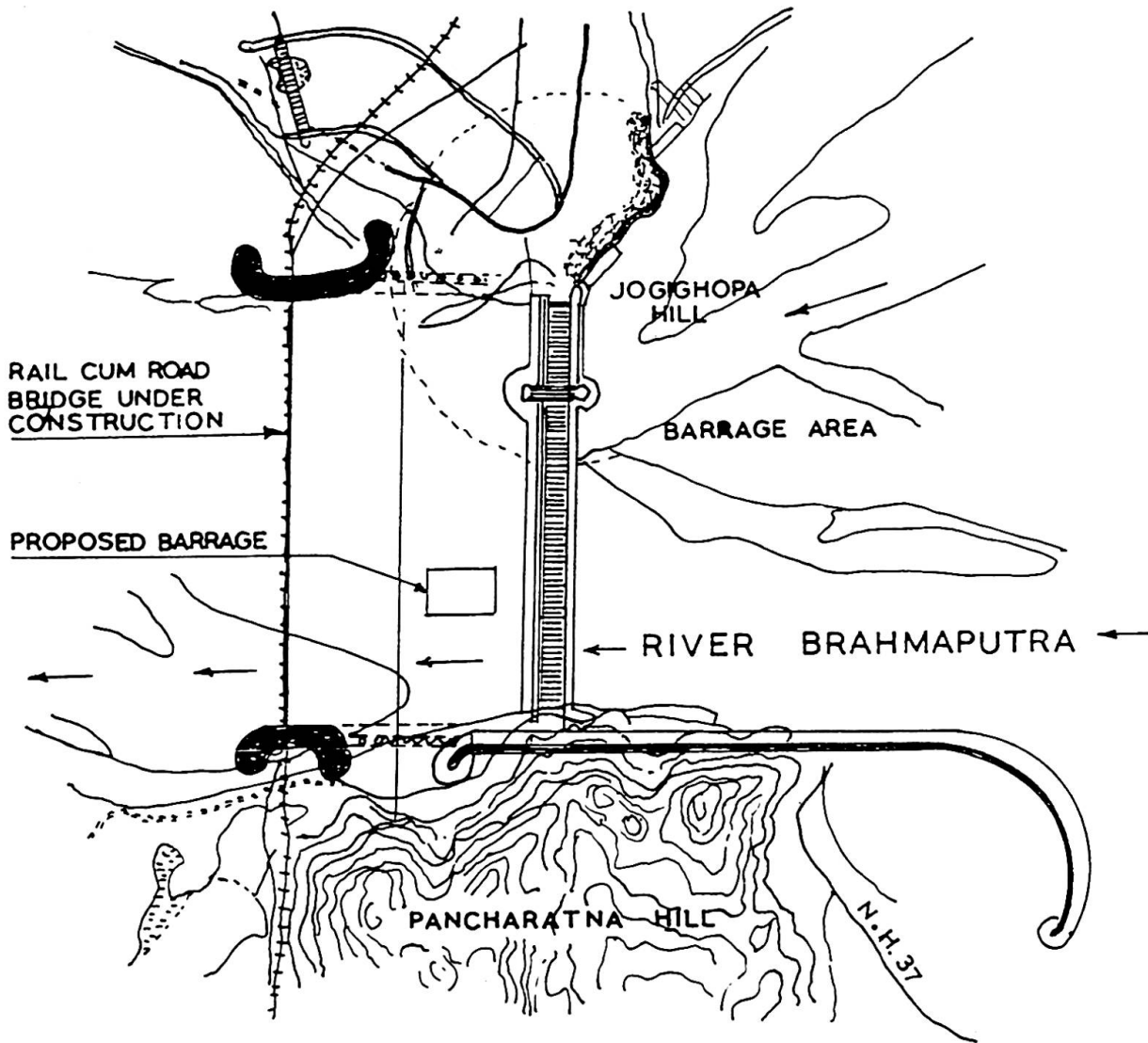

FIG. 7. LOCATION PLAN OF JOGIGHOPA BRIDGE
(UNDER CONSTRUCTION)

north and Pancharatna on the south (figure 7). However, this stability is limited to a very small area between the hill noses where the site of the future barrage is located. Immediately after leaving the nose of the Jogighopa hill the river has a tendency to sway towards the north and horizontal control is necessary for any structure to be constructed on the downstream of the proposed barrage. Jogighopa rail-cum-road bridge is sited at 1350 m downstream of the barrage axis. In between, the proposed barrage and the bridge axis, an inland port is to be developed. Combination of the requirements of these multiple structures namely barrage, port facilities and rail-cum-road bridge needed extensive hydraulic model studies for designing length and shape of river training works. A number of combinations (figure 8) were tried out by the research station, with the following terms of reference

- to confirm the bridge waterway from hydraulic behaviour.



- to have final indication of discharge intensities along the bridge.
- to confirm whether there is any probability of increase in the maximum scour around piers on account of port facilities.

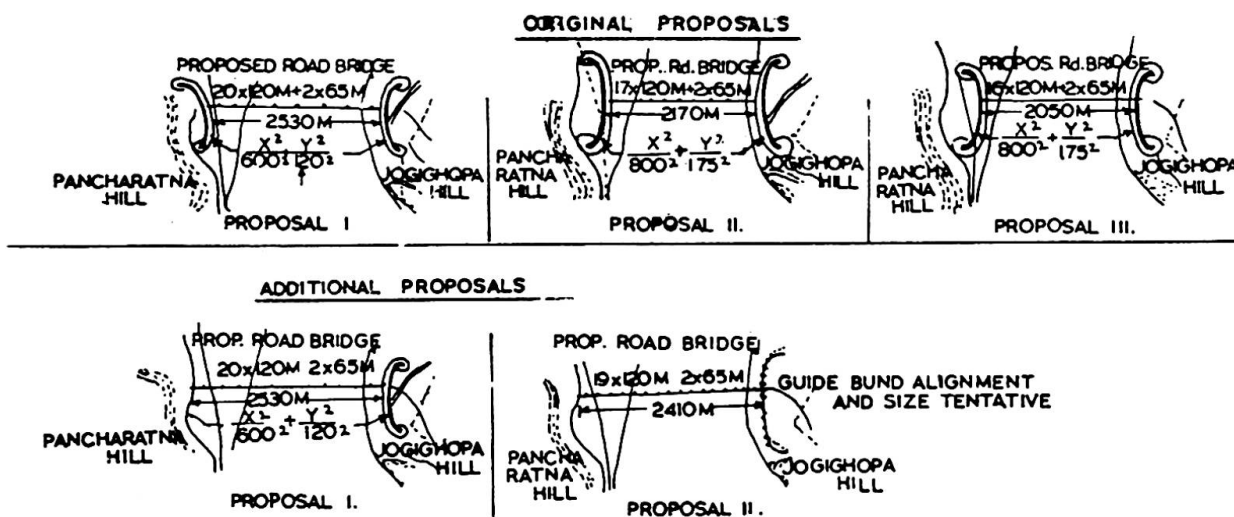

FIG. 8. ALTERNATIVE CONFIGURATIONS OF GUIDE BUNDS FOR JOGIGHOPA BRIDGE.

3.2.2 Model studies indicated that though the river has fairly uniform/stable flow conditions at the location, it is important to provide horizontal control with well designed guide bunds on either side.

3.2.3 Since on the north bank, port facilities are to be developed, a shorter guide bund of 450 m length has been designed. Model studies have also confirmed that due to the two control points, namely, Jogighopa hill and north guide bund in close vicinity, the river does not have any probability of developing full embayment and thus endangering the safety of rail/road approach to the bridge. Both the guide bunds have also been located in line with the planned guide bunds of the barrage so that there is a stable flow condition immediately down stream of barrage. At Jogighopa, south guide bund has been completed in 1990-91 and work on the north guide bund started in Nov. 1991 is expected to be completed by April, 1992. Construction of these bunds is highly mechanised and involved extensive logistic support. Important technical



features of Jogighopa guide bunds are as showing in figure 9.

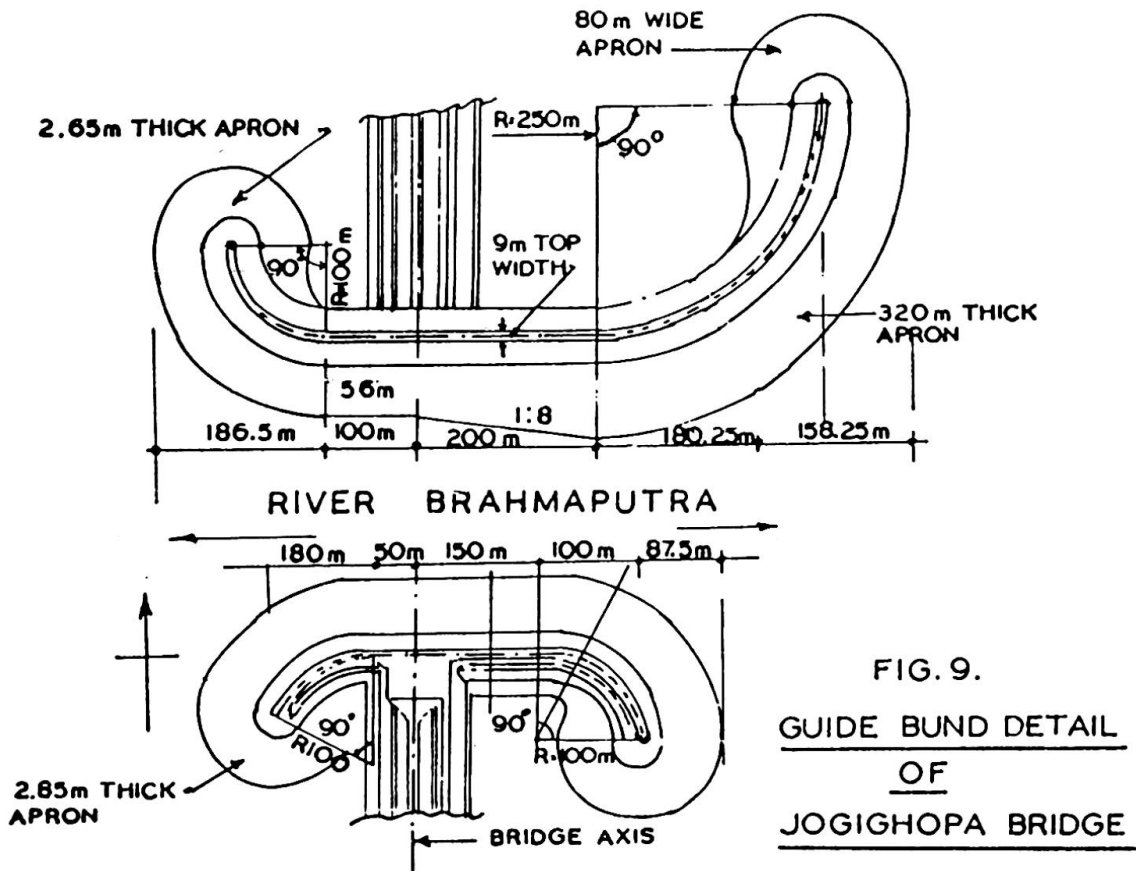

FIG. 9.
GUIDE BUND DETAIL
OF
JOGIGHOPA BRIDGE

3.3 Yamuna bridge at Karnal.

3.3.1 The river Yamuna rises in the Himalayas and flows in a south easterly direction for a distance of about 900 Kms before it joins the river Ganges at Allahabad. A bridge across this river is under construction near Karnal in the State of Haryana. Model studies for the various alternative sites have been carried out before the present site where the khadir width is 2.5 km. was adopted. The design discharge of 16000 cu. m/sec was based on the highest flood discharge of the year 1978 and the overall length of the bridge was kept as 600 m.

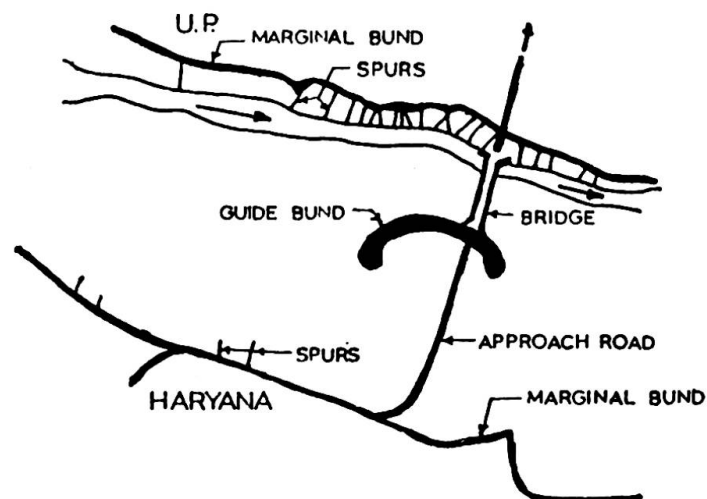

FIG.10. LAYOUT PLAN OF YAMUNA BRIDGE AT KARNAL



3.3.2 It was decided that the marginal embankment and spurs on the left hand side would be raised and strengthened and no guide bund would be provided on that side. On the right hand side an elliptical guide bund with straight lengths of 400 m and 87 m on the upstream and downstream respectively was provided. The radii of curvature and angles of sweep were respectively 215 m and 90° on the upstream side of guide bund and 90 m and 45° on the downstream side. (Fig. 10)

3.3.3 For the past many years the river was flowing with its main channel hugging the left bank. However, during the floods of 1988 when the work on the foundations of the bridge was already in progress, the river suddenly changed course, shifted by more than 1200 m towards the right and started flowing behind the location of the proposed guide bund. The question of increasing the length of the bridge to cover the new channel of the river was then considered, but it was finally decided to train the river and go ahead with the construction of the guide bund at its originally proposed location (refer Fig. 11)

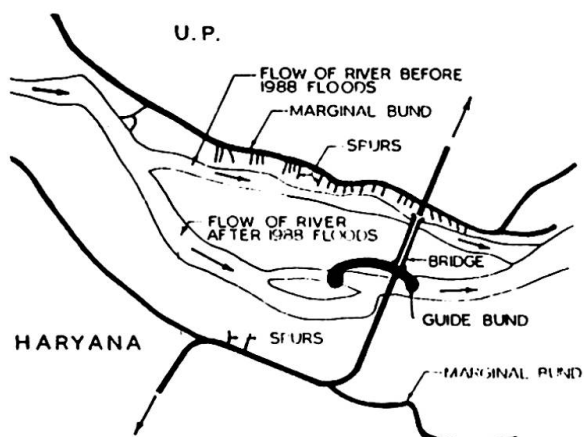

FIG.11. POSITION OF FLOW OF RIVER BEFORE AND AFTER 1988 FLOODS

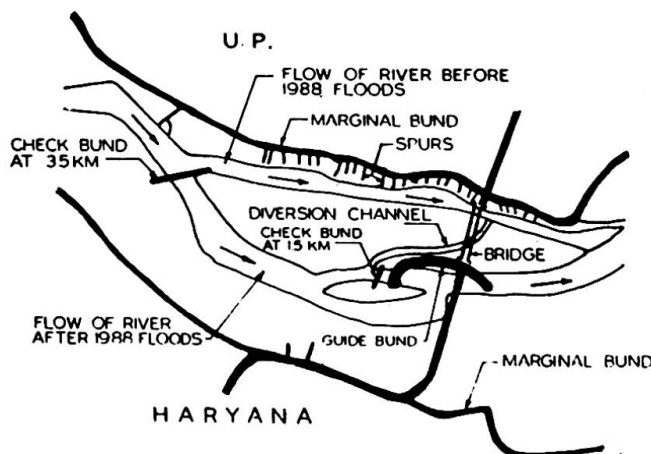

FIG.12 REMEDIAL MEASURES ADOPTED TO DIVERT THE FLOW OF RIVER

3.3.4 During the dry period, a diversion channel was cut in the bed of the river to guide the dry weather flow under the bridge. To achieve this, the flow in the main channel was blocked by construction of a 'check bund' or embankment. The first such 'check bund' constructed about 3.5 Kms. upstream of the bridge site was not successful in diverting the flow and a second check bund about 1.5 Kms. upstream of the bridge site had to be constructed. (refer Fig. 12)

3.3.5 This proved entirely successful in diverting and channelising the flow under the bridge. Thereafter the work of the guide bund and the connecting approach embankment was taken up on a war footing and completed in phases before the advent of the next floods. The behaviour of the river has been well controlled since then and the work on the bridge is now proceeding according to schedule.

Earthquake Hazard Mitigation in New and Existing Structures

Réduction du danger dans les structures exposées aux séismes

Reduzierte Erdbebengefahr bei neuen und alten Tragwerken

Frieder SEIBLE

Prof. of Struct. Eng.
Univ. of California,
San Diego La Jolla, CA, USA

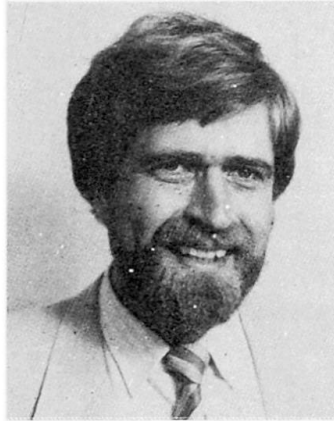

Frieder Seible has been a member of the UCSD faculty for 8 years. He has Civil Engineering Degrees from Germany, Canada and the USA and he is a member of the Seismic Advisory Board for Caltrans. His research interests combine large scale experimental testing and nonlinear analytical modelling of structural concrete systems.

M.J. Nigel PRIESTLEY

Prof. of Struct. Eng.
Univ. of California,
San Diego La Jolla, CA, USA



M.J. Nigel Priestley has received numerous international awards (ACI, PCI) for his earthquake engineering and structural concrete and research contributions. He has been a member of the faculty of the University of Canterbury, Christchurch, New Zealand for eleven years prior to joining UCSD.

SUMMARY

The unpredictable and devastating nature of earthquakes and the socio-economic consequences resulting from the failure of man-made structures emphasize the responsibility of the civil engineering profession with every major seismic event. Failures of civil structural systems in past earthquakes have shown that structural earthquake hazards exist around the world independent of the level of technical, cultural, social or economic development, and that earthquake hazard mitigation is a problem which needs to be addressed globally. Fundamental steps towards a rational and comprehensive structural systems design approach for earthquake hazard mitigation are outlined.

RÉSUMÉ

La nature imprévisible et dévastatrice des tremblements de terre et les conséquences socio-économiques résultant de la défaillance de structures anciennes et nouvelles mettent en relief la responsabilité des ingénieurs civils, chaque fois que se produit un séisme. Les ruptures de systèmes structuraux des bâtiments, survenues au cours de tremblements de terre récents et anciens, ont montré que les dangers dus aux séismes et encourus par les structures existent partout dans le monde, indépendamment du niveau de développement technique, culturel, social ou économique. De plus, la réduction du danger des tremblements de terre est un problème qu'il faut aborder globalement. Cet article esquisse les étapes fondamentales à effectuer vers une méthode rationnelle et globale de calcul des systèmes structuraux dans la réduction du danger aux séismes.

ZUSAMMENFASSUNG

Die Unvorhersagbarkeit und Zerstörungskraft von Erdbeben sowie die sozio-ökonomischen Folgen des Versagens von Menschen errichteter Bauwerke führen mit jedem Erdbeben die Verantwortung des Bauingenieurberufs neu vor Augen. Die Versagensfälle der Vergangenheit haben gezeigt, dass die bauliche Gefährdung weltweit ohne Ansehen des technischen, kulturellen, sozialen oder wirtschaftlichen Entwicklungsstands existiert und entsprechend angegangen werden muss. Der Beitrag umreißt die fundamentalen Schritte zu einem rationalen und umfassenden Entwurfskonzept für Tragwerke mit reduzierter Anfälligkeit auf Erdbeben.



1. INTRODUCTION

Earthquakes around the world have repeatedly demonstrated, and will continue to demonstrate, the vulnerability of man-made structural systems to seismic input. Major earthquakes in recent years such as Mexico 1985, Armenia 1988, Loma Prieta (San Francisco) 1989, Philippines 1990 and Costa Rica 1991 have shown, with their devastating consequences in terms of loss of life, loss and interruption of regional infrastructure and damage to public and private property, that a global need for structural earthquake hazard mitigation exists independent of technical, cultural, social or economic development levels.

The civil and structural engineering challenge and obligation to mitigate seismic structural hazards has to concentrate on two major areas, namely (1) the design of new structural systems and (2) the assessment and retrofit of existing structures to withstand probable earthquakes within defined performance criteria. For new structural design in seismic zones, deformation based performance limit states have to replace force driven conventional design criteria, and performance specifications for individual structures have to reflect not only structural properties but, equally importantly, consequences of partial or complete failure if a meaningful earthquake hazard mitigation is to be achieved. The seismic rehabilitation of existing structural systems has to be based on the latest research findings due to the just recently evolving nature of retrofitting knowledge and basic retrofitting technology, preceded by a realistic seismic performance assessment of the as-built and the retrofitted structures. Both new seismic design and seismic retrofit have to evaluate structural systems and component behavior differently from conventional gravity and live load design principles which are mostly force driven and based on lower bound strength principles. Since the unpredictable earthquake load case typically develops and exceeds the inherent strength of a structural system, seismic design must ensure that (1) the structure can perform inelastically through the formation of defined mechanisms, (2) the mechanisms are of a ductile nature which ensures large inelastic deformations and energy absorption without significant loss of capacity and (3) the safety margin to other non-ductile or brittle mechanisms forming in individual components is clearly established. Only if these deformation and capacity criteria are clearly established and adhered to, can the structure be expected to survive an earthquake which exceeds the structural elastic capacity.

In the following, ideas and principles are summarized which form the basis for a rational comprehensive seismic design approach, and evolving procedures are outlined for the increasingly important seismic retrofit of existing and aging structural systems. Even though the principles presented are equally applicable to building, bridge and lifeline structures, the examples will concentrate on bridge structures damaged during the 1989 Loma Prieta earthquake due to the extensive nature of available as-built structural and research data. A general overview is provided on seismic structural problems followed by a discussion of their mitigation through new design and relevant assessment and retrofit measures for existing structural systems based on the latest research data.

2. SEISMIC STRUCTURAL PROBLEMS

Earthquakes show their devastating nature through damaged and collapsed man-made structural systems which in turn are responsible for loss of life, damage to regional infrastructure, and interruption of associated essential services. The three categories of structures supporting our socioeconomic systems are buildings, bridges and lifelines, and all three are equally affected by major seismic events.

The partial or complete collapse of buildings is typically a major source of earthquake related casualties, and can be attributed to various problem areas ranging from conceptual systems selection and design to the construction, usage and maintenance. Major earthquakes in China and Armenia with heavy building failures suggest problems with the selected structural system, i.e. unreinforced masonry or the structural systems connection detailing of prefabricated reinforced concrete buildings, respectively. Additional system problems frequently encountered in seismic building failures are pounding effects of adjacent structures, soft stories, irregular

geometry with significant stiffness changes in the horizontal and vertical directions, and inadequate footing performance. However, to label certain building systems as inherently unsafe has been proven wrong by the performance of similar systems in other earthquakes and by in-depth structural systems research. It is not an inherent fault with the selected structural system but rather an inadequate understanding of seismic input, seismic structural systems response and appropriate mitigating design principles.

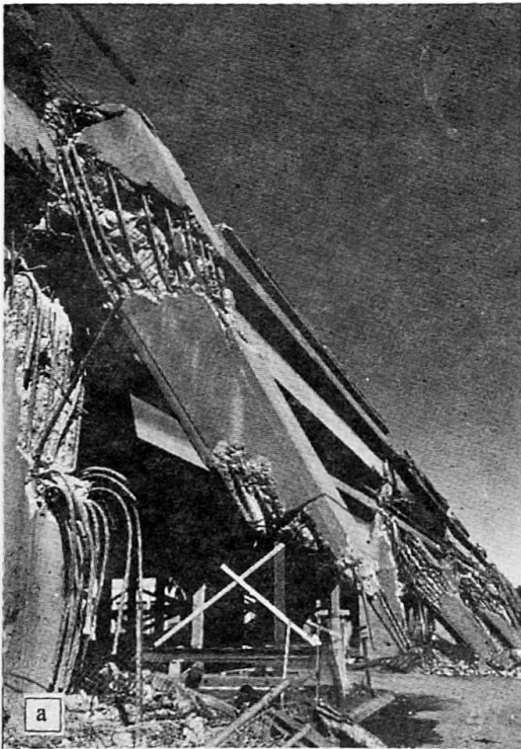

I-880
Oakland, CA
October 1989

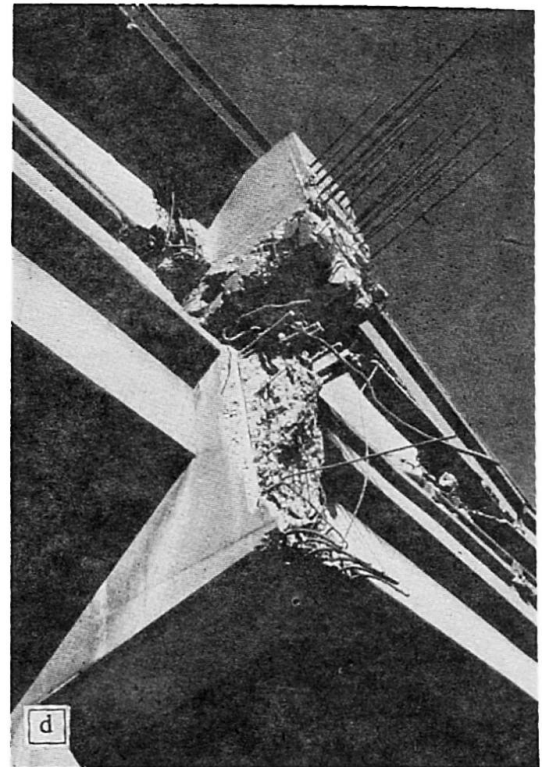

FIG 1. Bridge Damage During the 1989 Loma Prieta Earthquake

Bridge damage and/or collapse is noticed mostly due to its impact on traffic circulation patterns following a major earthquake. Quite often, it is the bridges most needed for post-earthquake search and rescue and relief operations which are collapsed or have to be closed. The duration of closure directly impacts the economic post-earthquake recovery of the affected region. Again, while many seismic bridge problems (see Fig. 1) can be associated with the choice of the structural system, the earthquake hazard also could have been mitigated by appropriate design



and detailing measures. [1]. Primary seismic problems in bridge structures include foundation and footing problems (e.g. liquefaction), expansion joint and seating problems due to lack of seat width and/or force constraint across the joint, inadequate member capacities in flexure and/or shear, lack of redundancy in the structural system to allow alternate load paths, and the detailing of joints between primary structural members such as footing/column connections, column/cap beam and cap beam/superstructure connections.

Loss of lifelines can be devastating both immediately during the seismic event, i.e. rupture of water reservoirs and dams, or following the earthquake in the form of fire danger from ruptured gas lines, disrupted water supplies to extinguish fires and epidemic sanitary and health problems from interrupted fresh and waste water systems.

Since the forces resulting from an earthquake in our manmade structural systems are unpredictable due to the unknown time, duration, epicentral location, magnitude, and dynamic characteristics, it is virtually impossible to design for these forces in a deterministic manner. Also, to design for the probable or most credible force levels elastically to prevent seismic structural damage is in most cases technically difficult and economically and aesthetically prohibitive. Thus, mitigation efforts have to assume that the structure will be loaded beyond the inherent force capacity and that inelastic action and damage will occur. However, this inelastic action can be controlled to occur in a ductile mode with known mechanisms at predetermined locations which still allow the system to deform and dissipate seismic energy without losing its critical function of sustaining gravity loads [2]. As part of a comprehensive seismic hazard mitigation design approach, not only the performance of the structural system but also the hazard in the form of ground motion and soil conditions and the consequences of structural failure in the form of potential loss of life and economic impact have to be evaluated in assessing the seismic risk of our manmade structures. In the following, some of these principles are outlined using bridge design examples, both for new designs and retrofit of existing structures.

3. SEISMIC EARTHQUAKE HAZARD MITIGATION

A comprehensive seismic structural hazard design approach should include the components of (1) Risk Assessment, (2) Equivalent Seismic Load Input, (3) Component Assessment and/or Design (4) Systems Evaluation, (5) Final Design or Retrofit. These components are schematically outlined in Fig. 2.

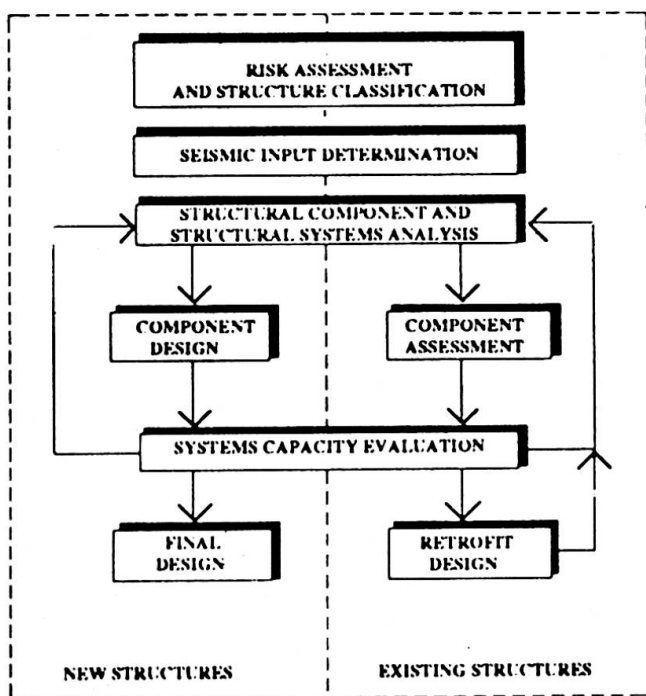

FIG 2. Seismic Design Process

The seismic risk assessment for a structure should involve the three principal components of hazard, structure and consequence. The hazard component reflects the probabilistic seismic input in terms of magnitude, probability of occurrence and soil/geological characteristics of the most probable seismic ground excitation. The structure component should address structural performance characteristics in terms of redundancy, detailing for inelastic action and critical geometry. Finally, the consequence component should address the importance of the structure and provide input on potential for loss of life consequences of failure or closure of the structure under evaluation. These three categories can be combined in a cumulative or multiplicative weighted risk algorithm to determine an estimate of the seismic risk for the structure. As an example of a risk assessment algorithm Fig. 3 shows the component and category tree structure currently used by

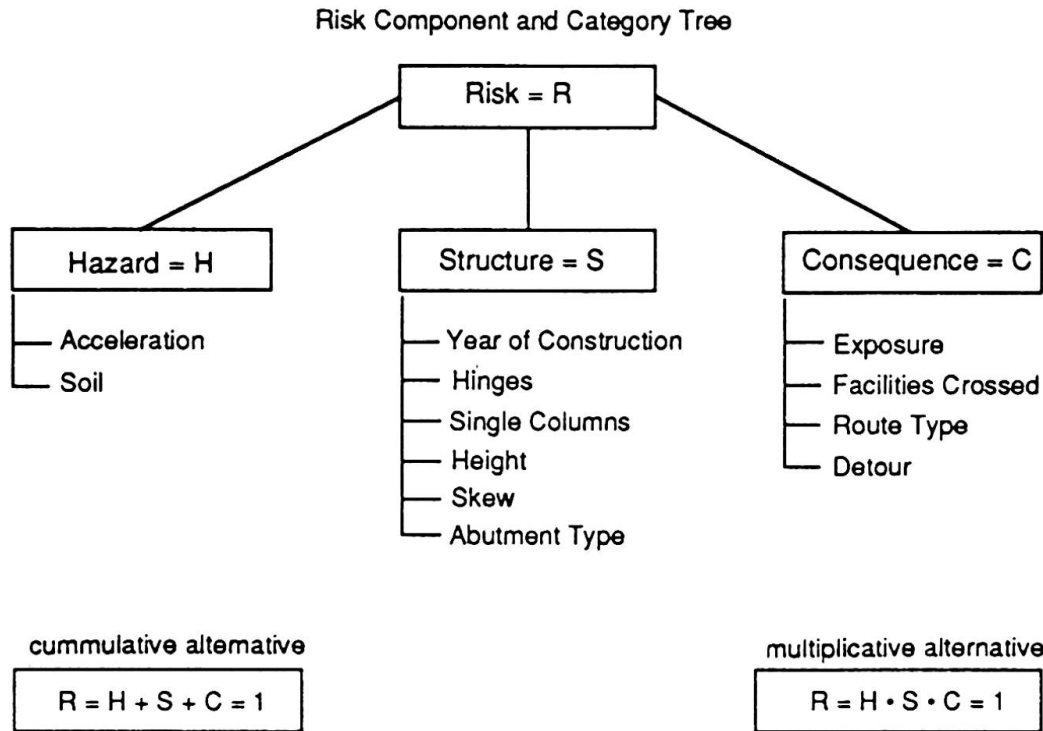

FIG 3. Seismic Risk Assessment Algorithm

California Department of Transportation (Caltrans) to assess the seismic retrofit priorities of over 24,000 bridge structures in California [3]. This risk evaluation can now be used to determine critical design limit states for the structural system and guidelines on how these design limit states should be achieved.

In the design phase of new structures or retrofits, design limit states should address the expected performance level and state of the structure during and after the earthquake, and should be directly tied to the structural importance and risk priority derived above. The essential seismic design limit state for any structural system is the collapse limit state defined as the state of structure at which gravity loads can no longer be supported. All structural systems should be designed to avoid this limit state but depending on the importance or risk level additional, more stringent design limit states should be added. A damage control limit state which prevents collapse but allows repairable damage of various degrees to occur could be formulated based on the importance of the structure and the consequences of a prolonged shutdown. Finally, essential facilities or structures servicing or leading to them should be designed based on serviceability limit states which would allow limited inelastic action resulting in minor damage and in uninterrupted and continued safe operation of the structure. One way to meet descriptive design limit states performance criteria as outlined above is to limit the inelastic structural response of the system since increased inelastic response is directly tied to increased damage levels. For example, inelastic structural response can be quantified by displacement ductility levels of the complete system, as sketched out on Fig. 4, where an idealized bilinear elasto-plastic approximation of the actual load-deformation relationship of the center of mass of the system defines the yield displacement level $\mu = 1$ (at $\Delta = \Delta_y$) and subsequent damage or ductility levels μ ($\Delta = \mu\Delta_y$) as multiples of the yield displacement. For long period structures, the equivalent elastic deformations are approximately equal to the actual (inelastic) deformations which allows a reduction of the equivalent elastic forces to the idealized plastic capacity level, i.e. the elastic force reduction factor $R = \mu$. For shorter period structures an "equal energy" approach can be used to define the relationship between R and μ .



The derived elastic force reduction can now be used to establish an appropriate deterministic load input for the structural system in the form of acceleration response spectra which determine equivalent static seismic loads on the system.

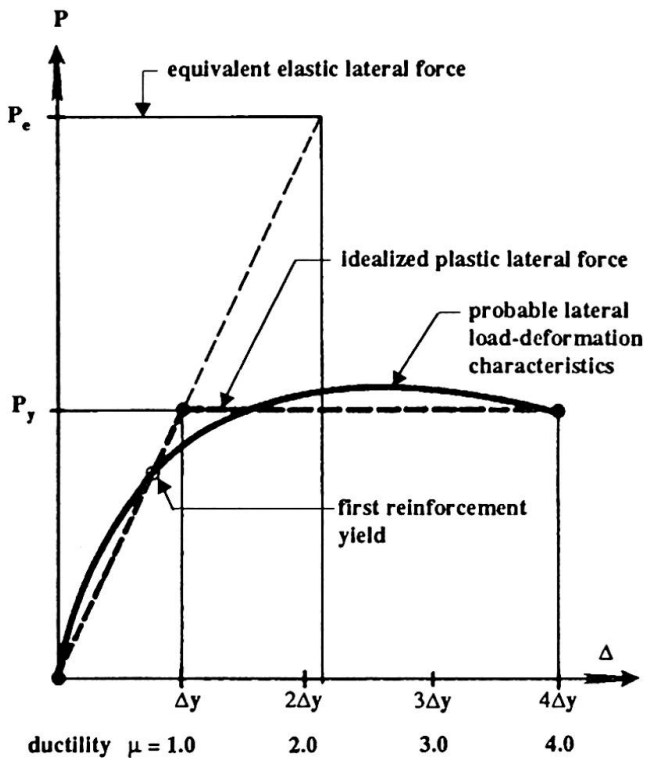

FIG 4. Load Deflection Behavior and Equivalent Elastic Forces

The actual member design for new structures and the assessment of actual member capacities for existing structures requires an evaluation of the most probable capacities of the component, i.e. a best estimate of the actual strength and deformation characteristics. Since in an inelastic design the earthquake will mobilize the inherent strength, a key design consideration has to be the formation of ductile mechanisms (not brittle shear or anchorage failures) which allow the structure to deform inelastically without significant loss of capacity. This design approach requires realistic capacity checks and comparisons of local mechanisms within each element and of adjacent joints, connections and members to ensure a global ductile systems mechanism. This capacity design concept was introduced by Park and Paulay [2] and finds increasing acceptance as one of the most powerful design tools in earthquake hazard mitigation. The same capacity based approach can also be applied to assess the seismic vulnerability of existing structures and to design, if necessary, appropriate retrofit concepts.

Based on this outlined design philosophy, new or existing structural systems can be designed, assessed, and or retrofitted, to allow various levels of inelastic deformation and damage as defined by the specified performance design limit states. An example of this capacity based approach is provided in the following example of a bridge assessment for one of the bridge structures damaged during the 1989 Loma Prieta earthquake.

4. ASSESSMENT OF EXISTING STRUCTURES

The key component in a comprehensive capacity based seismic design approach is the correct assessment of the component and systems behavior under combined gravity and seismic loads. Some of the principles involved in this assessment phase are outlined below in the examples of outrigger bents severely damaged during the 1989 Loma Prieta earthquake.

The realistic assessment of the component capacities and critical mechanisms of an existing bridge structure is based on the following steps:

1. Determine the most probable material properties; For existing concrete structures the actual concrete strength has significantly increased with time over the nominal design strength f'_c and reinforcement typically features higher yield than the specified nominal grade. Unless material tests on the existing structure are performed, assumptions of a 50% increase in concrete strength and a 10% increase in reinforcement yield strength are reasonable, i.e. $f'_c = 1.5 f'_{c,design}$ and $f_y = 1.1 f_{y,design}$.

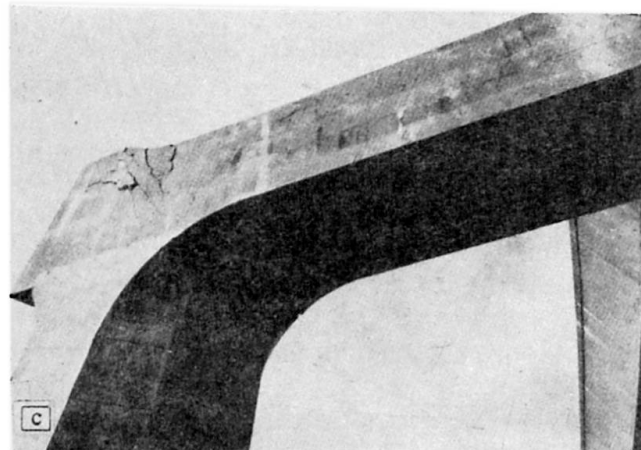
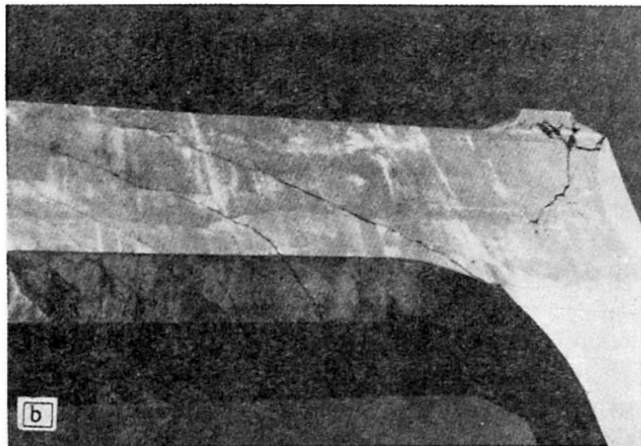
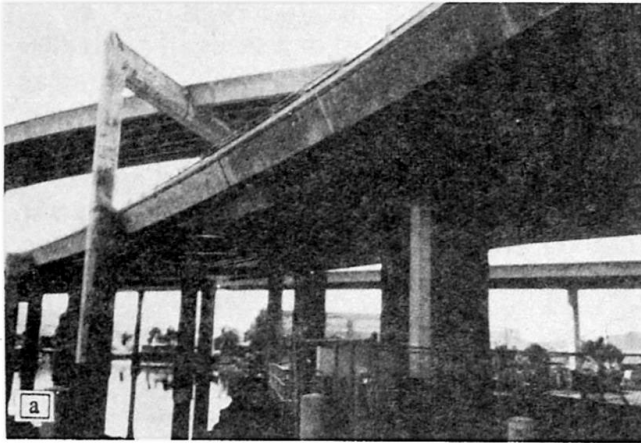

FIG 5. Earthquake Damage, Loma Prieta 89, China Basin Viaduct

2. Flexural capacities for the individual beam and column members are determined using above material properties and section analysis techniques which are based on a realistic concrete stress-strain relationship including axial load, confinement effects, and strain hardening. Flexural member capacities need to be adjusted where inadequate development length of the main reinforcement (see Fig. 1d) or lap splices with insufficient lap length or confinement limit the full capacity development under fully reversed cyclic loads. Detailed guidelines on the proper assessment of reinforcement development were proposed by Priestley [4].
3. The probable member shear capacities are determined, using a model which accounts for degrading concrete contributions with increasing ductility demand, truss action for stirrup reinforcement, and axial load effects from gravity loads or prestress as outlined by Priestley [4].
4. To determine the critical member mechanism, the plastic shear demand V_p of the member is determined based on full flexural plastic hinging and compared with the actual member shear capacity V_n . If $V_n > V_p$ a ductile flexural member failure mechanism can be expected. If $V_p > V_n$ the member might fail in a brittle shear mode prior to reaching its full flexural mechanism.
5. A combined gravity and earthquake (static lateral load) analysis of the complete gravity load support system or bent (beam - column assemblage) is now performed as a stepwise linear elastic event scaling procedure to determine the sequential formation of critical member mechanisms all the way to the critical systems collapse mode.

6. From the final global collapse mechanism, critical lateral load level and corresponding internal forces can now be determined. A check on joint shear in beam-column and column-footing connections and on footing capacities has to be performed with the obtained internal collapse loads based on capacity design principles [2] to ensure that no other degrading or brittle mechanisms develop in connecting or adjacent elements. If these capacity checks show deficiencies in the joints or adjacent members, appropriate systems load and deformation capacity reductions based on the expected level of cyclic degradation, see Priestley [4], have to be made.



7. The derived lateral load and expected deformation capacity for the structural system can now be compared to the required seismic load demand and the associated deformation or ductility design limit state as outlined in Fig. 2 to determine appropriate retrofit measures, as summarized by Priestley and Seible [5].

A general overview of the first outrigger bent on I-280 (China Basin Viaduct, San Francisco) is shown on Fig. 5a and damage patterns encountered during the earthquake are depicted in Figs. 5b and c. The as-built reinforcement details of the bent cap and columns are depicted in Fig. 6 and moment capacities and demands in the cap beam for separate and combined gravity and seismic loading are shown in Fig. 7. Following the outlined procedure, the bridge bent, shown in Figs. 5 to 7, was assessed [1]. Cap beam capacities were found well below corresponding column capacities and were thus critical for the overall seismic assessment. Member shear capacities were found to exceed flexural plastic shears. A unit lateral (seismic) load was applied to the bridge bent model and scaled to levels E_I and E_{II} where combined seismic and gravity loads form sequential mechanisms in the cap beam as shown in Fig. 7.

Lateral response force levels of $\ddot{E} = 0.63 \text{ g}$ and $\ddot{E} = 0.69 \text{ g}$ in the two directions, respectively, were found to cause complete global flexural mechanisms to develop. Particularly under loading to the right, see Figs. 6 and 7, the termination of negative or top reinforcement at a distance of 6.1 m from the column centerline is cause for the onset of a negative moment crack which propagates toward the column in shear aided by the lack of cap beam shear reinforcement in this region, see Fig. 6. A wide flexural-shear crack was observed in this region, as predicted, see Fig. 5c.

Joint shear cracking was calculated for both joints at lateral force levels less than those corresponding to the first flexural hinge formation. Approximate values corresponding to a joint shear stress of $0.33\sqrt{f'_c}$ MPa are $\ddot{E} = 0.45 \text{ g}$; and $\ddot{E} = 0.40 \text{ g}$, respectively. Thus, significant joint shear stress, as seen in Figs. 5b and c, can be expected. While the level of cracking visible in the positive knee joint moment regions of the bent cap beam indicated that the cap did not reach first flexural hinge formation, the shear stresses in the joints were high enough to cause joint failure. Hence the response accelerations appear to have exceeded 0.4 g in each direction. However, since both cap beam and joint mechanisms form at very similar lateral load levels and the distress pattern in the cap beam also reflects the reinforcement inadequacies, no repair or retrofit measure but rather complete replacement of the entire bent was recommended [1].

The second outrigger bent assessment example from the 89 Loma Prieta earthquake was performed for bent #38 on the I-980 southbound connector in Oakland, CA. Reinforcement details and dimensions of the critical knee joint are shown in Fig. 8. Based on capacity checks for both cap beam and columns, as outlined above, and from subsequent sequential failure mechanism analyses [1], the joint shear stress levels in the knee joint at the collapse limit state were found to be in excess of $0.5\sqrt{f'_c}$ and $0.35\sqrt{f'_c}$ [MPa] for closing and opening knee joint moments, respectively. Thus, joint shear damage can be expected prior to the development of any flexural ductile beam or column mechanism as demonstrated by the encountered distress patterns during the Loma Prieta earthquake, depicted in Fig. 9. Since existing beam and column capacities and reinforcement detailing were satisfactory to allow limited ductile performance, repair and retrofitting of the joint was performed by complete removal of the joint concrete, added joint shear reinforcement and an increased joint size.

While the above capacity based assessment examples were performed for existing bridge structures, similar capacity based procedures should also be employed in new structural systems design, see Fig. 2, to ensure ductile structural systems which allow seismic energy dissipation through well defined and appropriately detailed ductile mechanisms.

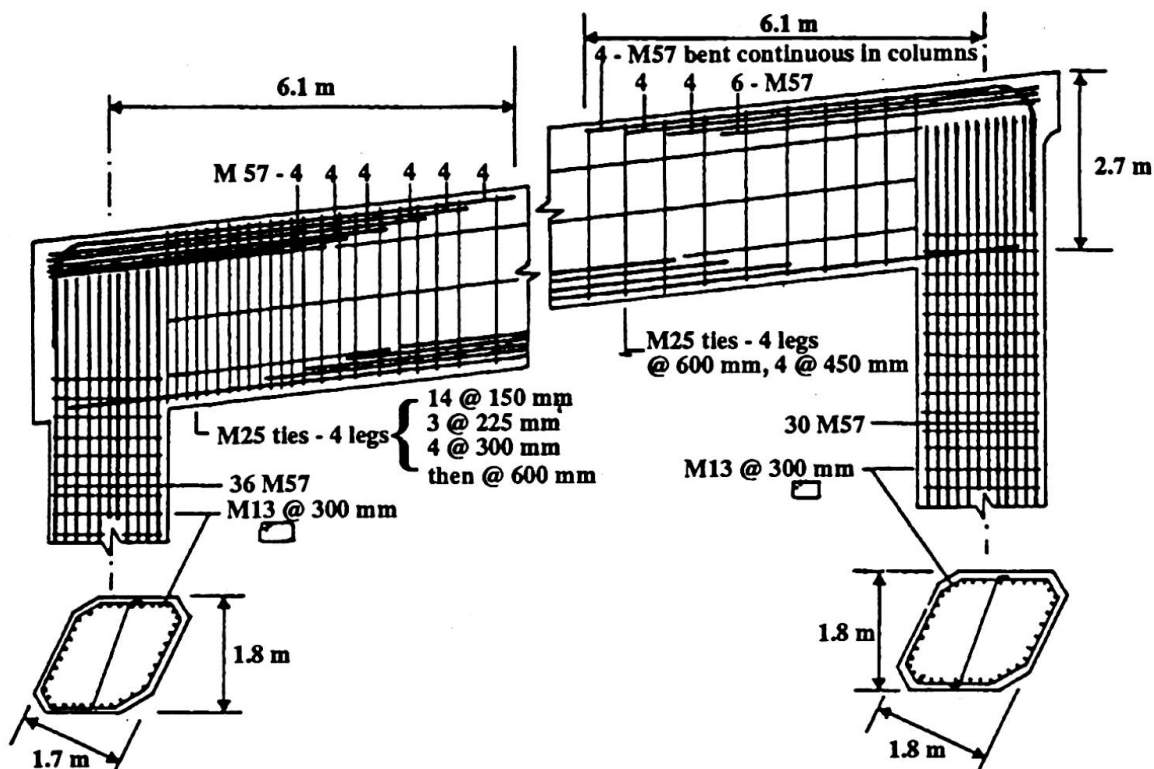

FIG 6. China Basin, Bent N₁-35 Reinforcement

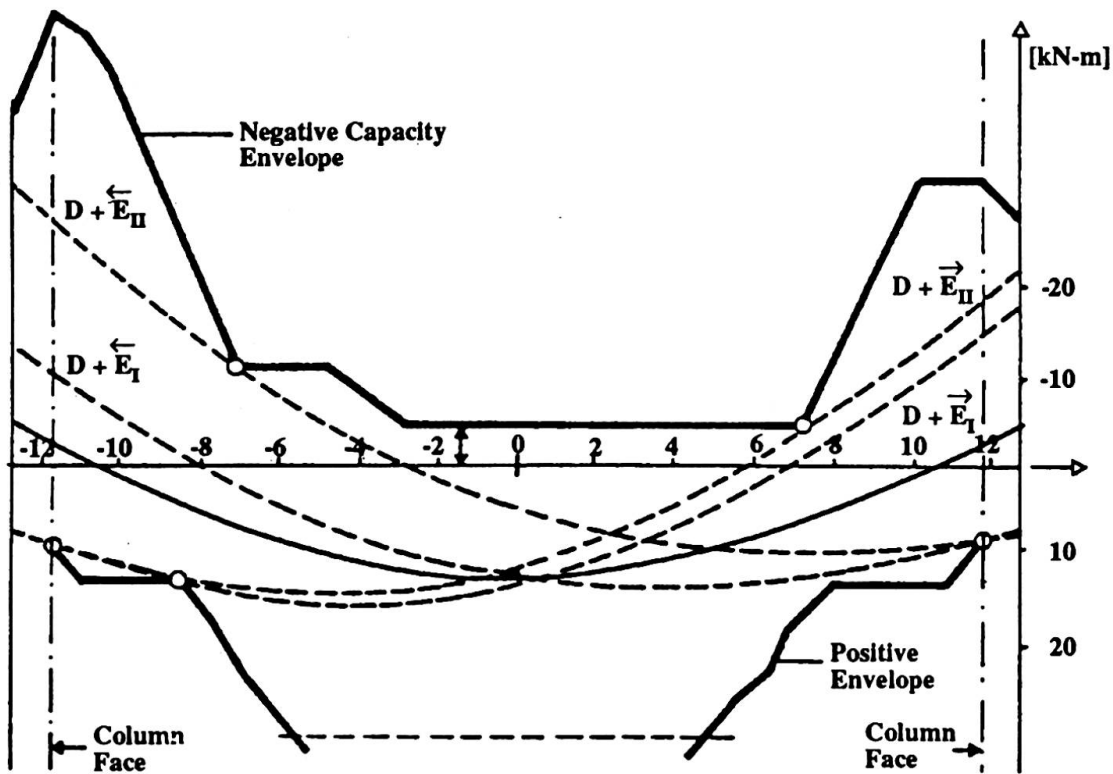

FIG 7. China Basin, Bent N₁-35, Moment Capacities and Demand

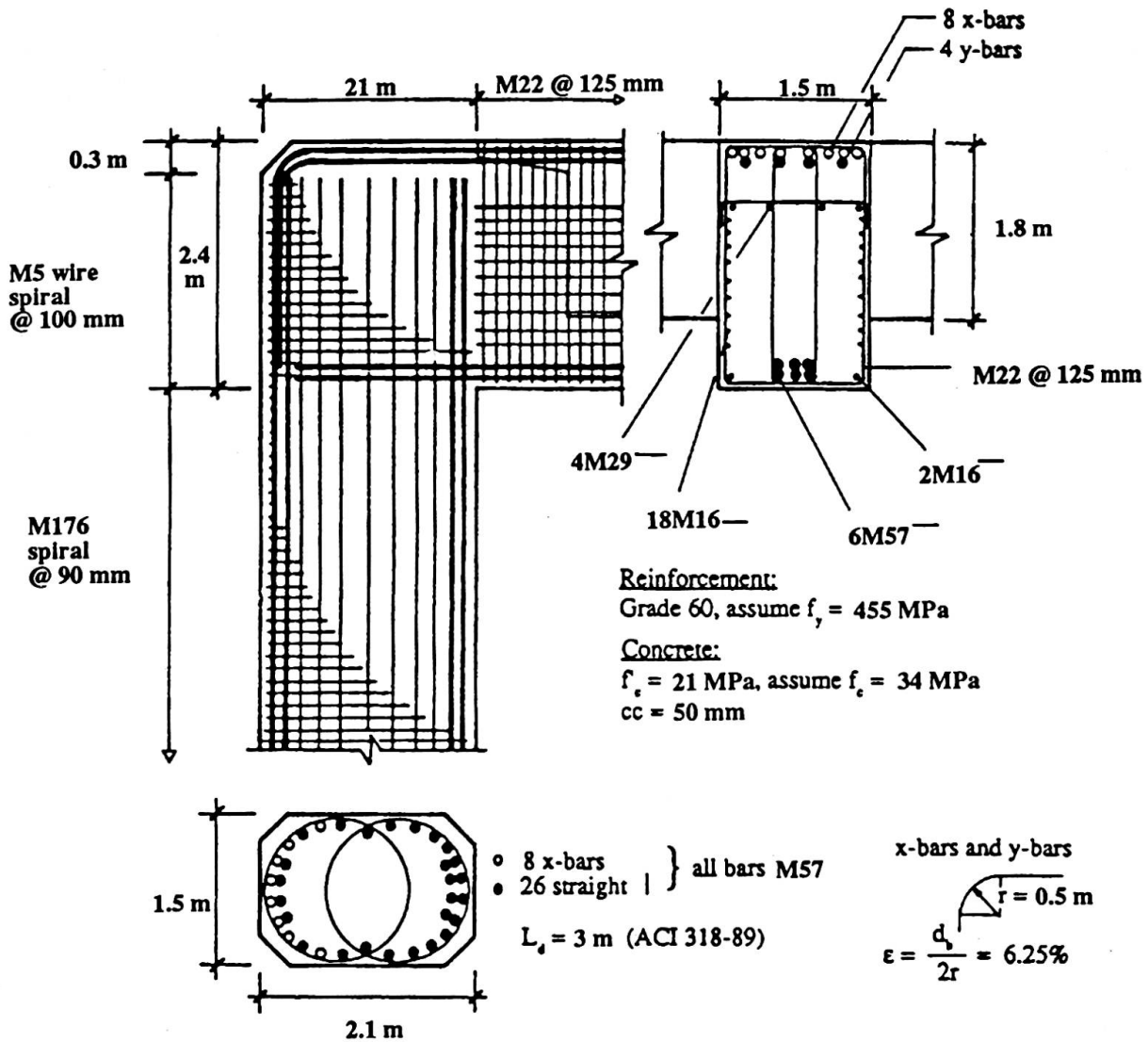

FIG 8. I-980, Bent #38 Reinforcement Details

5. CONCLUSIONS

To mitigate earthquake hazards arising from new or existing structural systems, a comprehensive seismic design and assessment approach is needed which accounts for seismic risk of the structure in terms of importance, consequence of failure, and probability of occurrence of the seismic design event. This seismic risk evaluation needs subsequently to be employed to define expected structural performance levels in the form of descriptive performance design limit states on one hand, and in determining appropriate design guidelines on the other hand. The deterministic portion of the seismic design process should be based on a capacity philosophy where local and global structural failure mechanisms are determined based on realistic or most probable materials and performance characteristics. The goal is to design a retrofit for the development of ductile well confined (flexural) plastic hinge mechanisms which will allow the structure to deform inelastically without significant lateral capacity deterioration. Capacities of adjacent members, connections and joints, have to be designed with sufficient margin to ensure flexural plastic hinge development considering axial load effects, concrete overstrength, confinement effects and actual reinforcement strength including strain hardening. Seismic structural design based on the above principles will allow a comprehensive and rational seismic structural hazard mitigation process.

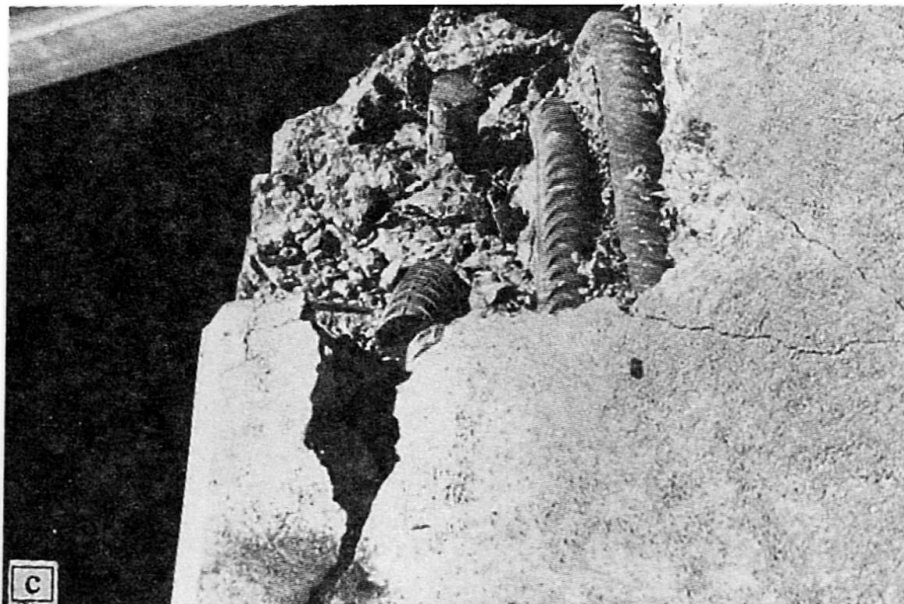
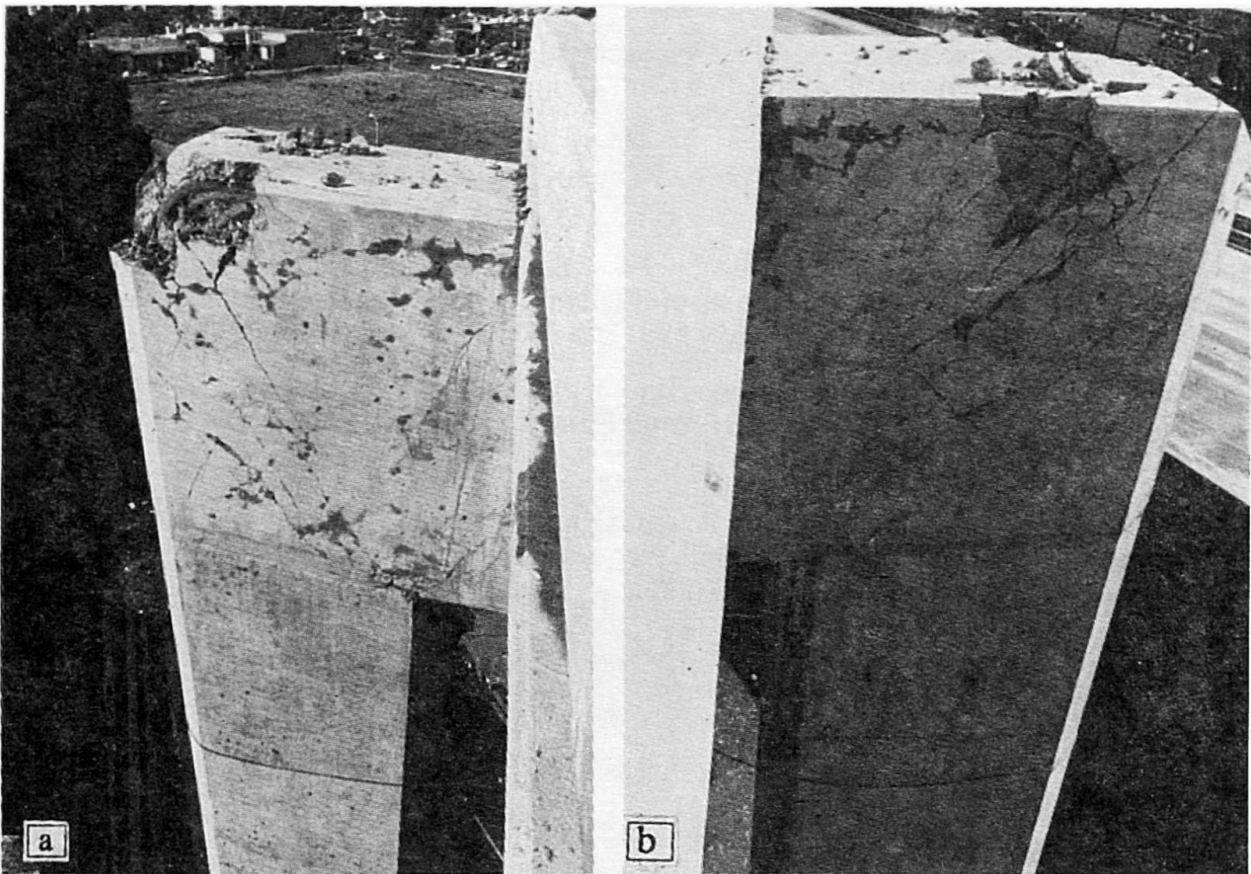

FIG 9. I-980 Oakland, CA, Encountered Damage Patterns



REFERENCES

- [1] PRIESTLEY M.J.N. and SEIBLE F., "Assessment of Bridge Damage During the Loma Prieta Earthquake," University of California, San Diego, Structural Systems Research Project, Report No. SSRP-90/01, March 1990.
- [2] PARK, R. and PAULAY T., "Reinforced Concrete Structures," John Wiley & Sons, New York, 1975, pp. 769.
- [3] MARONEY B. and GATES J., "Seismic Risk Identification and Prioritization in the Caltrans Seismic Retrofit Program," University of California, San Diego, Structural Systems Research Project, Report No. SSRP-91/03. July 1991, pp. 27-54.
- [4] PRIESTLEY M.J.N., "Seismic Assessment of Existing Concrete Bridges," University of California, San Diego, Structural Systems Research Project, Report No. SSRP-91/03, July 1991, pp. 84-149.
- [5] PRIESTLEY M.J.N., and SEIBLE F., "Design of Seismic Retrofit Measures for Concrete Bridges," University of California, San Diego, Structural Systems Research Project, Report No. SSRP-91/03, July 1991, pp. 197-250.