

# Dickwandige Profile in Stahlkonstruktionen

Autor(en): **Bucak, Ómer / Mang, Friedrich**

Objektyp: **Article**

Zeitschrift: **IABSE congress report = Rapport du congrès AIPC = IVBH  
Kongressbericht**

Band (Jahr): **14 (1992)**

PDF erstellt am: **12.07.2024**

Persistenter Link: <https://doi.org/10.5169/seals-13834>

## **Nutzungsbedingungen**

Die ETH-Bibliothek ist Anbieterin der digitalisierten Zeitschriften. Sie besitzt keine Urheberrechte an den Inhalten der Zeitschriften. Die Rechte liegen in der Regel bei den Herausgebern.

Die auf der Plattform e-periodica veröffentlichten Dokumente stehen für nicht-kommerzielle Zwecke in Lehre und Forschung sowie für die private Nutzung frei zur Verfügung. Einzelne Dateien oder Ausdrucke aus diesem Angebot können zusammen mit diesen Nutzungsbedingungen und den korrekten Herkunftsbezeichnungen weitergegeben werden.

Das Veröffentlichen von Bildern in Print- und Online-Publikationen ist nur mit vorheriger Genehmigung der Rechteinhaber erlaubt. Die systematische Speicherung von Teilen des elektronischen Angebots auf anderen Servern bedarf ebenfalls des schriftlichen Einverständnisses der Rechteinhaber.

## **Haftungsausschluss**

Alle Angaben erfolgen ohne Gewähr für Vollständigkeit oder Richtigkeit. Es wird keine Haftung übernommen für Schäden durch die Verwendung von Informationen aus diesem Online-Angebot oder durch das Fehlen von Informationen. Dies gilt auch für Inhalte Dritter, die über dieses Angebot zugänglich sind.

## Dickwandige Profile in Stahlkonstruktionen

Thick-Walled Sections in Steel Structures

Profilés à âme épaisse dans les ouvrages métalliques

### Ómer BUCAK

Dr.-Ing.  
Univ. Karlsruhe  
Karlsruhe, Deutschland



Ómer Bucak, geboren 1947, studierte an der Universität Karlsruhe Bauingenieurwesen, Promotion über das "Ermüdungsverhalten von Hohlprofilknoten". Er arbeitet auf dem Gebiet des Stahl- und Anlagenbaues, des Ermüdungsverhaltens von Stahl und Aluminium als auch deren Verbindungen.

### Friedrich MANG

Prof. Dr.-Ing.  
Univ. Karlsruhe  
Karlsruhe, Deutschland



Friedrich Mang, geboren 1934, promovierte an der Universität (TH) Karlsruhe als Bauingenieur. Er habilitierte auf dem Gebiet "Stahl- und Leichtmetallbau". Er arbeitet auf den Gebieten des Stahl- und Anlagenbaues, der Werkstoffermüdung und deren Verbindungen.

## ZUSAMMENFASSUNG

Der vorliegende Bericht gibt die Ergebnisse der statischen und dynamischen Untersuchungen an dickwandigen Walzprofilen wieder. Die Ergebnisse von Bauteilen mit Stumpfstoßen mit und ohne Schweißfehler sowie solche mit Stegaussteifungen werden mitgeteilt und die Ergebnisse mit denen aus hochfesten Stählen verglichen.

## SUMMARY

This paper describes static and fatigue investigations on butt welded rolled thick-walled sections as well as full-scale tests on specimens with web attachments. Information is given on the results of structural members with and without weld defects and those with web stiffeners and the results are compared with those from high-strength steels.

## RÉSUMÉ

Le présent rapport donne les résultats des recherches statiques et dynamiques sur les profilés laminés à âme épaisse. Les résultats obtenus sur les éléments de structure joint bout à bout avec et sans défauts de soudage, ainsi que ceux se rapportant aux nervures raidies, sont fournis et comparés à ceux obtenus sur les aciers à haute résistance.



### 1. GENERAL

The reason for the application of thick-walled steel sections and predominantly rolled sections is that effective dimensions and bigger cross section areas can be economically produced through large pre-fabrication in the rolling mill. The first rollings in series from wrought iron were carried out in about 1800 to 1820 as rail rollings.

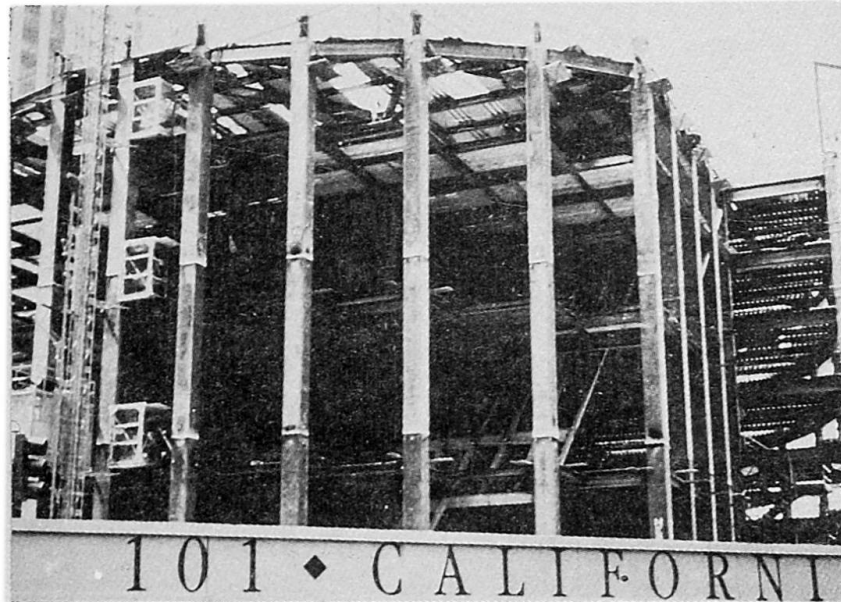

Fig. 1 High-rise building in the USA

The first usable sections regarding steel construction developed as L- sections in 1831. In 1845 welded steel pipes and in 1849 H-sections (double T-sections) had been rolled. Nowadays, large I-sections with flange thicknesses of 125 mm and a total height of 1200 mm can be rolled without any problems. Even for the high-strength qualities such as StE 460, a steel quality can be gained by additional alloy elements. Modern steel production methods such as QST (Quenching and Self-Tempering) qualities of ARBED-Luxembourg facilitate higher yield limits and tensile strengths at lower values for the carbon equivalent.

This is advantageous when welding such thick-walled sections. Up to now, the main field of application was the high building construction (fig. 1). In the last years these sections have been also used as girders subject to bending in high building construction, since the overall height could be saved. The application of large size, especially of thick-walled steel structural members necessitates the knowledge of various material properties determining the bearing behavior. The modern methods in steel production and especially the rolling technology have eliminated or largely limited the disadvantageous characteristics as they have been originally attached to classified rolled sections [1, 2, 3].

### 2. COMPRESSION MEMBERS MADE OF THICK-WALLED ROLLED SECTIONS (COLUMNS)

Main test series

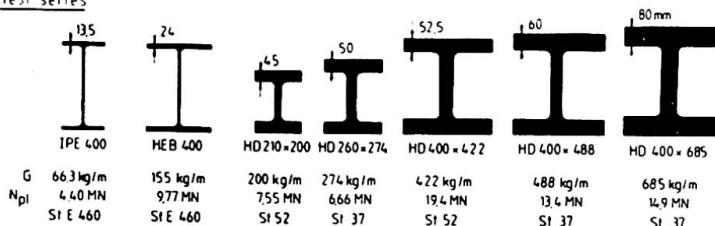

Large size rolled sections have already passed their test for the application as compression members. For the classification in buckling stress curves of Eurocode 3 [1] corresponding investigations have been made in Karlsruhe with the sections (flange thicknesses up to 122 mm) illustrated in fig. 2 [2].

Additional tests

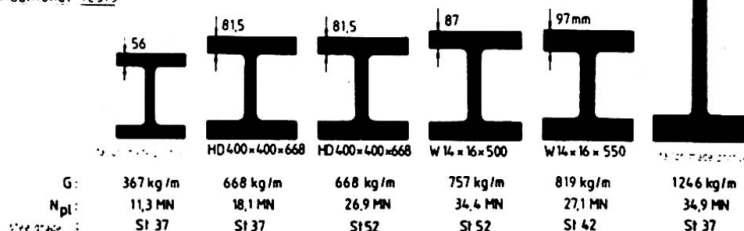

Up to then it was necessary to classify the rolled sections with flange thicknesses of about 40 mm in the European buckling stress curves "d".

Fig. 2 Rolled sections for investigations on buckling made in Karlsruhe

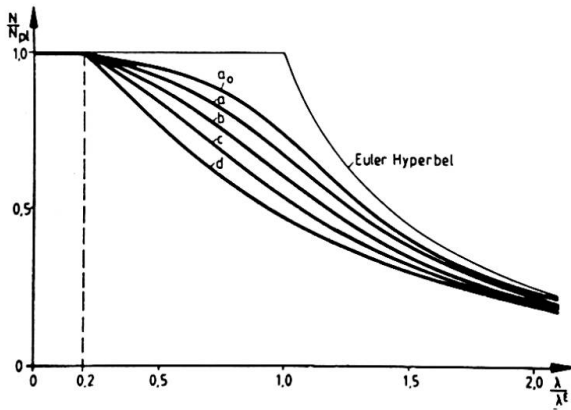

Fig. 3 shows the test specimen with a flange thickness of 97 mm and a length of 8,0 m in the 50 MN-testing machine of the Versuchsanstalt für Stahl, Holz und Steine.

The new classification into the buckling stress curves of Eurocode 3 are shown in fig. 4 with the arrangement that only beginning from a flange thickness of 100 mm a classification in curve d and in the flange thickness range between 40 and 100 mm; curve b and c are important.

cross section	buckling above axis	buckling curve
rolled H-sections		
$t \leq 40 \text{ mm}$	y - y z - z	a ( $a_0$ ) b (a)
 $\frac{h}{b} > 1,2$ $40 \text{ mm} < t < 100 \text{ mm}$	y - y z - z	b (a) c (b)
	$t \leq 100 \text{ mm}$	y - y z - z
$t > 100 \text{ mm}$	y - y z - z	d d

[1] For steel grades StE 460 and StE 690 the more favourable buckling curves given in brackets can be used, but with flange thicknesses smaller than 40 mm.

Fig. 4 Classification of the rolled sections according to Eurocode 3, edition Nov 1989 [1]

In addition to the application as columns or compression members, the use of thick-walled sections can also be useful as bending members or beams or chord members of girders.

Fig. 3 Test specimen with a flange thickness of 97 mm and a length of 8.0 m in the 50 MN-testing machine of the University of Karlsruhe

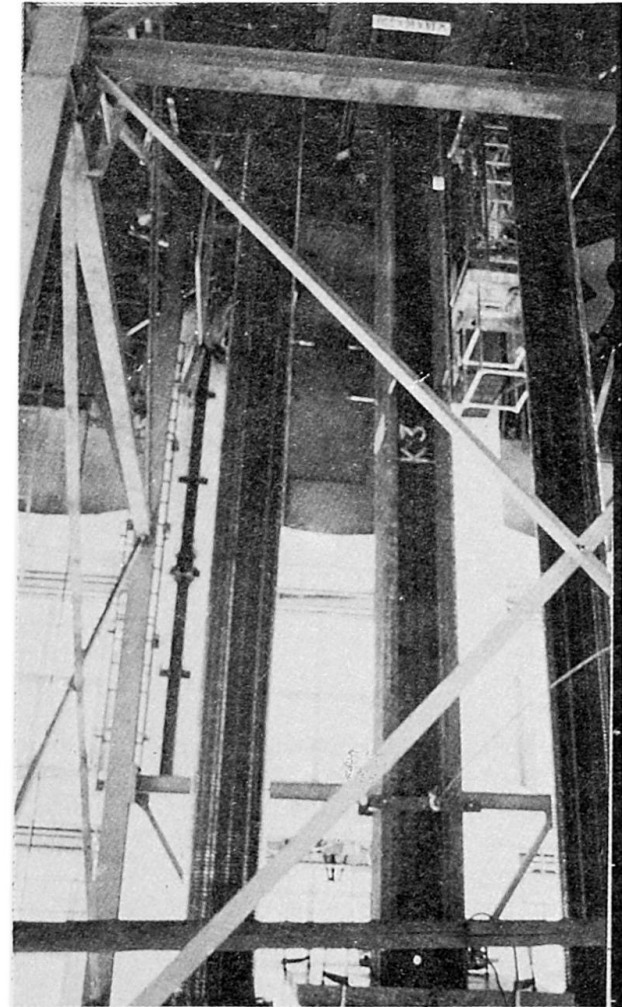

### 3. BEAMS MADE OF THICK-WALLED ROLLED SECTIONS

#### 3.1 Beams with butt welded connections

Since the welding technology has been applied, their application for thick-walled rolling products was regarded as critical, if at all, they were only permitted under limiting conditions. When introducing the old German standard DIN 4100 [4], the reasons for this have been indicated as follows:

- areas of segregation that cannot be excluded, especially in the area of the neck, transition from flange to web
- combination of residual stresses regarding rolling and welding,
- non satisfying possibilities of non-destructive tests.



These restrictions are presently not valid or can rather be excluded, such as for example areas of segregation on rolled section (due to modern fabrication methods).

Siteshop welding lower flange with hole

(Girders are already fixed and cannot be turned)

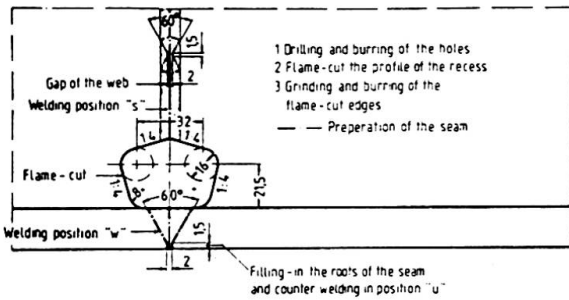

With joints of the site shop, conditions should be avoided in predicaments, if possible. For this reason a welding on one side in the form of V-butt welds for flange welds is realized (figs. 5 and 6).

In contrast to this, X-butt welds can be selected for workshop conditions with the possibility of turning the beam to positions that are favorable for welding. The latter are to be classified as more favorable with regard to welding and require less deposited metal and thus, less time for welding and less heat entry.

Fig. 5 Butt welded connections with holes on beams

Workshop welding lower flange without hole

Siteshop welding lower flange without hole

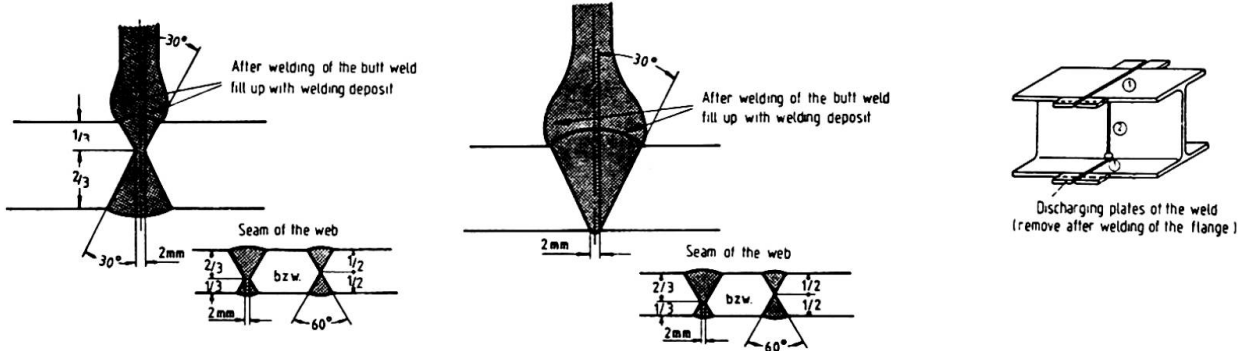
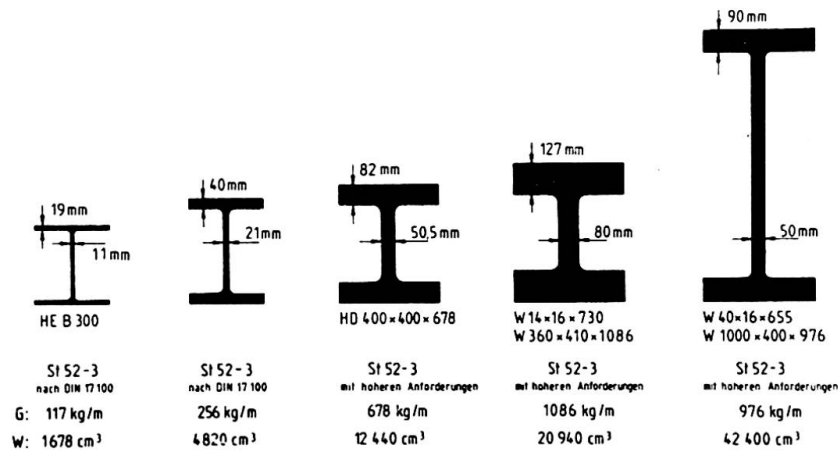

Fig. 6 Butt welded connections without holes on beams

The main test series have been carried out on the hot rolled beams HE300B and HE400M. Figures 10a and 10b show the test results of the fatigue tests separately for both design variants. Data of the test specimens produced under site shop and under workshop conditions have not been distinguished. The results of the fatigue investigations on the sections W920x420x876 with a flange thickness of 82,0 mm were entered into the same diagrams. From this it becomes evident that the test values are in a good accordance with the main test series. Test results on specimens with 80/82 mm flange thickness in QST-quality are marked with the symbols ( ) and specimens with 30 mm flange thickness ( ).



The load bearing behavior of butt welded, thick-walled beams under static and fatigue load has also been investigated in Karlsruhe. Fig. 7 shows the dimensions of the sections in the tests.

Fig. 7 Thick-walled rolled sections for bending tests



Fig. 8 shows the type of fracture after a fatigue test for a butt welded specimen with holes. The fracture starts from the outside area of the tension flange and at the same time from the hole to the web. For the design without hole, the fracture started from the outside of the tension flanges (fig. 9).

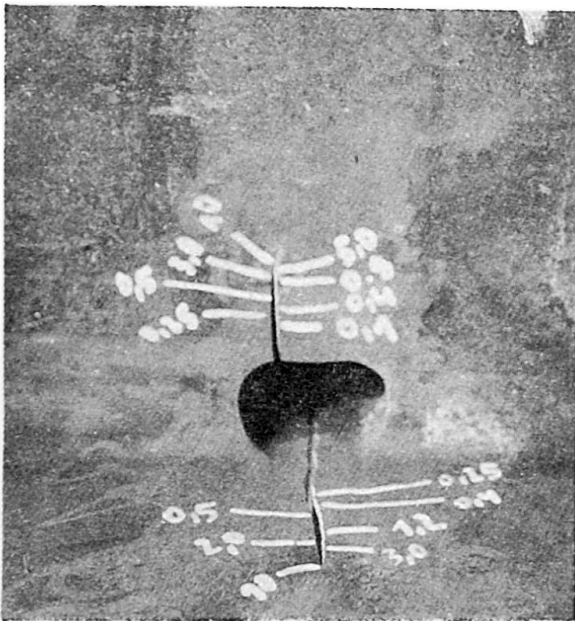

Fig. 8 Fracture of the butt welded specimens with holes



Fig. 9 Fracture of the butt welded specimens without holes

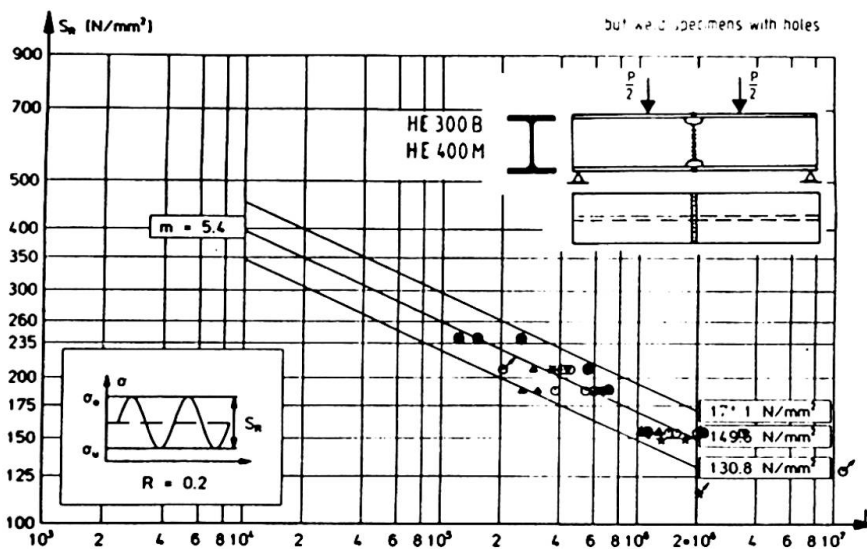

Fig. 10a Results of the fatigue tests on butt welded specimens with I-sections. Test specimens with holes.

The better position of the less notched design without holes can be seen from the categories for assessment. In this connection it has to be pointed out that the butt welds with holes result in better welding conditions and less design risks.

Some specimens showed unacceptable big failures after welding so that they normally cannot be admitted for application. Nevertheless, these specimens have been tested in order to investigate the influence of such lack of fusion on the fatigue behaviour. In figure 11, the results of the investigations are recorded comparatively to the specimens without defects.

It can be seen from this presentation (fig. 11) that the specimens with lack of fusion show bigger differences in the endurance compared to those specimens without weld defects. The slope of the S-N-line for this type of construction is lower and this resulted in the lower difference of the  $\sigma$  between the test results with and without weld defects.

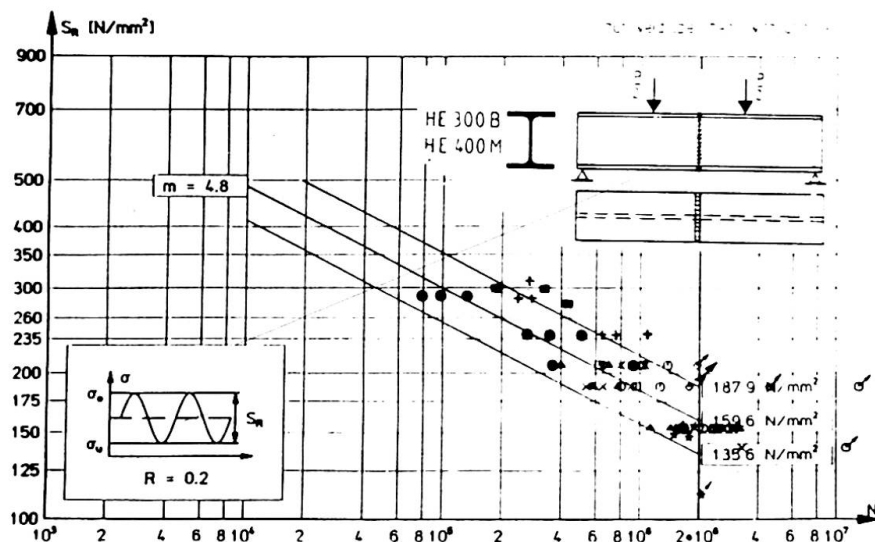

Fig. 10b Results of fatigue tests on butt welded test specimens with I-sections without hole

The fractures and load deformation diagram according to fig. 12 furnished the proof of a good, i.e. usual plastification capacity after a rapidly increased load up to the fracture. The fracture loads for various design variants do not show any significant differences.

By means of fig. 13 it is to be demonstrated that, nevertheless, risks do exist, if welding parameters are not kept carefully and brittle fractures are provoked.

The danger of brittle fracture with a wrong treatment of such thick-walled structural elements resulted in the fast development of new steel grades such as those of the QST-method

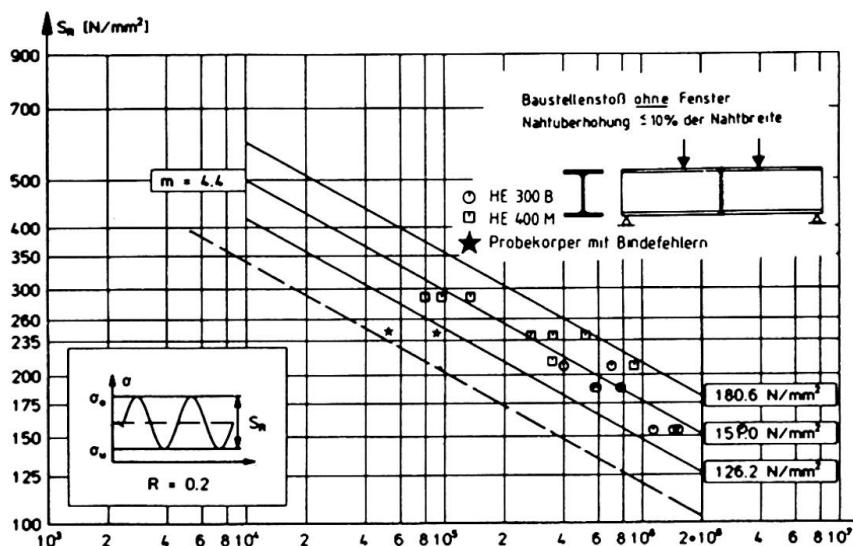

Fig. 11 Influence of lack of fusion on the fatigue strength of large-size structural members. Butt weld without hole.

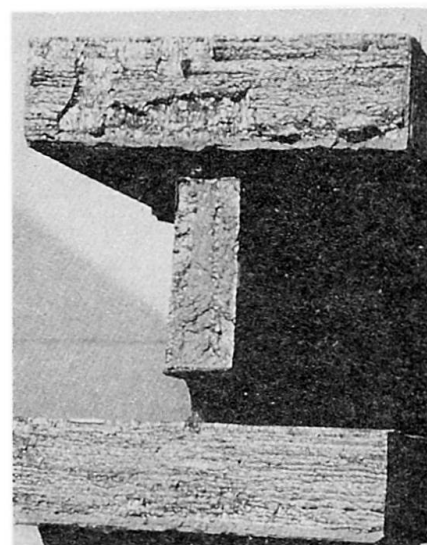

Fig. 13 Fracture and complete cross section

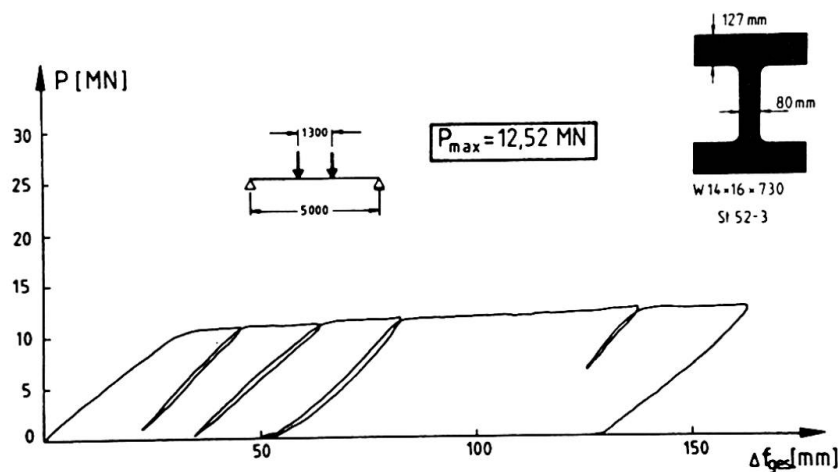

Fig. 12 Load deformation diagram for thick-walled rolled beams

#### 4. CONCLUSIONS

Following the presentation, welding of thick-walled sections can be done without any problems. The developments in the field of metallurgy, rolling methods and the possibilities of processing allowed the application of thick-walled sections in welded structures. Thus, a more favourable production of large-size structures is available.