

Poster

Objektyp: **Group**

Zeitschrift: **IABSE congress report = Rapport du congrès AIPC = IVBH
Kongressbericht**

Band (Jahr): **14 (1992)**

PDF erstellt am: **05.07.2024**

Nutzungsbedingungen

Die ETH-Bibliothek ist Anbieterin der digitalisierten Zeitschriften. Sie besitzt keine Urheberrechte an den Inhalten der Zeitschriften. Die Rechte liegen in der Regel bei den Herausgebern.

Die auf der Plattform e-periodica veröffentlichten Dokumente stehen für nicht-kommerzielle Zwecke in Lehre und Forschung sowie für die private Nutzung frei zur Verfügung. Einzelne Dateien oder Ausdrucke aus diesem Angebot können zusammen mit diesen Nutzungsbedingungen und den korrekten Herkunftsbezeichnungen weitergegeben werden.

Das Veröffentlichen von Bildern in Print- und Online-Publikationen ist nur mit vorheriger Genehmigung der Rechteinhaber erlaubt. Die systematische Speicherung von Teilen des elektronischen Angebots auf anderen Servern bedarf ebenfalls des schriftlichen Einverständnisses der Rechteinhaber.

Haftungsausschluss

Alle Angaben erfolgen ohne Gewähr für Vollständigkeit oder Richtigkeit. Es wird keine Haftung übernommen für Schäden durch die Verwendung von Informationen aus diesem Online-Angebot oder durch das Fehlen von Informationen. Dies gilt auch für Inhalte Dritter, die über dieses Angebot zugänglich sind.



POSTER



Durability Aspects of Cylindrical Roof Construction in Ferrocement

Durabilité de toitures cylindriques en béton armé

Dauerhaftigkeit von Tonnendächern aus Stahlbeton

M.R. SETHIA

Assoc. Prof.
Univ. of Jodhpur
Jodhpur, India

R.C. GUPTA

Lecturer
M.R. Eng. College
Jaipur, India

SUMMARY

Architectural considerations in modern building construction demand curved roof construction in parts of the building. These roofs, when cast by conventional techniques, require costly shuttering and consume more materials and labour. Analysis design and construction technique used for a ferrocement hood roof covering an area of 3.0 m x 4.8 m have been discussed. Considerations for durability of the structure have also been discussed.

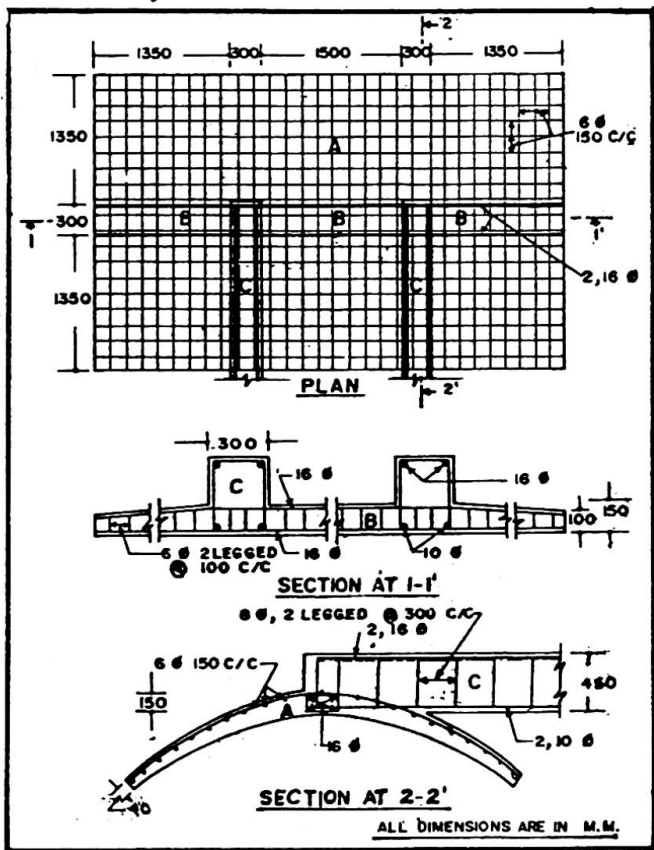

Fig. 1 Geometrical and structural details

1. DESCRIPTION OF STRUCTURE

The geometrical and structural details are shown in Fig. 1. The structural components are : The cylindrical hood roof (A); The central beam (B) and The cantilever beams (C).

2. ANALYSIS AND DESIGN

Components A,B and C the structure have been conventionally analysed for loads as per IS:875-1964[1] to obtain design values of bending moments and shearing forces. The stability of the structure has been ensured as per IS:456-1978[2]. Working stress method of design, as applicable to reinforced concrete, has been used.

3. EXECUTION PROCEDURE

The cantilever beams (C) and the central beam (B) were cast with shuttering. The curved reinforcement bars of the hood shell (A) were embedded into the central hood beam (B) prior

to its casting. The making of the hood shell was taken up after completion of curing of (B) and (C) and removal of formwork. The reinforcement along the length of the shell was tied to the curvilinear reinforcement of the hood shell. Two layers of chicken-mesh, one at the top and the other at the bottom of the



Fig. 2 Front view of hood

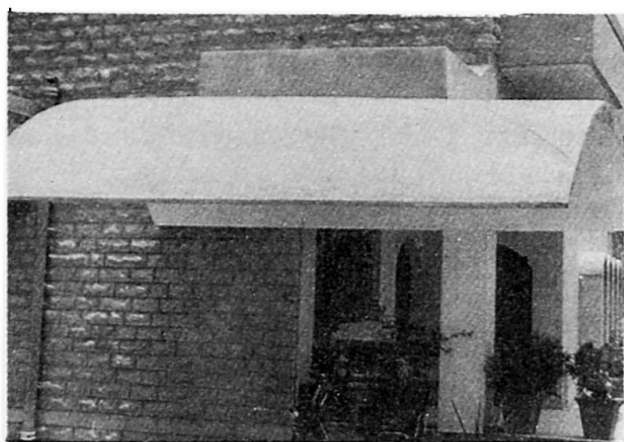

Fig. 3 Side view of hood

reinforcement grid of the shell, were used. Cement-sand mortar, with some coarser particles up to 10 mm size, was splashed on to the bottom surface of the shell in strips of 300 mm width and 50-75 mm thickness along the axis of the shell. Strip formation was commenced on the sides of the central hood beam and terminated at the free edges of the shell. Each strip of 300 mm width on each side of the hood beam was splashed one after the other with an interval of 24 hours to ensure initial hardening and gain of strength. This process was repeated till the formation of full shell. The shell was then finished at the top surface as well as the bottom surface. The finished hood structure is shown in Fig. 2 and 3.

4. DURABILITY CONSIDERATIONS

The successful performance of the ferrocement depends greatly on its durability than on its strength properties. Freezing and thawing; wetting and drying; attack of chemicals, bacteria, wind and water waves; free lime and calcium hydroxide in cement; impurities in aggregates and water; prolonged chemical reactions of concrete ingredients; poor construction practices,

reversal of stress cycles and overloading are the factors effecting durability. Staining; scaling and pitting; wear; dimensional instability, cracking, reduction in strength due to corrosion of steel are the symbols of deterioration and ageing.

The damage to the structure of mortar, which is the main corrosion resistant cover to reinforcement, is retarded in ferrocement construction due to efficient arrest of the cracks by chicken-mesh and also due to the presence of high cement content. Proper design, selection of proper material, control on execution, provision of protective coatings and avoiding overloads are the measures to further ensure the durability of ferrocement construction.

5. CONCLUSION

- The ferrocement technique is useful for innovative applications in modern building construction.
- A greater durability is ensured due to richer concrete mix and efficient arrest of cracks by chicken-mesh.
- Economy in the cost of shuttering, use of materials and labour is inherent with the ferrocement construction.

REFERENCES

1. IS:875-1964, 'Code of Practice for Structural Safety of Buildings: Loading Standards', Indian Standards Institution, New Delhi.
2. IS:456-1978, 'Code of Practice for Plain and Reinforced Concrete', Indian Standards Institution, New Delhi.



Steel-Concrete Composite Arch

Arches mixtes acier-beton

Stahl-Beton-Verbundbogen

Arne JUTILA

Prof.
Helsinki Univ. of Technology
Espoo, Finland

Lauri SALOKANGAS

Civil Eng.
Helsinki Univ. of Technology
Espoo, Finland

Harri YLI-VILLAMO

Civil Eng.
Helsinki Univ. of Technology
Espoo, Finland

1. INTRODUCTION

Steel-concrete composite structures are widely used as beams, slabs and columns in bridge and structural engineering. Still, as far as the authors know, applications or test results of composite arches are not reported so far. Composite arches have many advantages compared to traditional reinforced concrete or steel arches. The steel section can be used as formwork for concrete and no scaffolding is necessary. The compression capacity of concrete is improved by prevented lateral expansion. Finally, through to bond, even without connectors, a composite action is formed which considerably increases the ultimate load carrying capacity of such an arch.

2. LABORATORY TESTS

To examine the strength and behaviour of steel-concrete composite arches two specimens were tested in the Laboratory of Bridge Engineering of Helsinki University of Technology in spring 1990. The span and the rise of the arches were 3.5 m and 0.7 m, respectively. The cross-section was composed of 6 mm thick steel plates welded together to form a 190 mm wide and 126 mm high U-shaped profile which was filled with concrete (Fig. 1). To the bottom plate 80 mm high studs were attached in pairs at an interval of 100 mm. The side walls were connected by 8 mm diameter threaded steel rods with about 180 mm interval. The structure was hinged at the footings and loaded by three equal point loads at the quarter points of the span. The steel grade was Fe 235 and the compression strength of concrete (150 mm cube) was 38.5 N/mm² when tested. Vertical deflection at the rise and steel strains were measured.

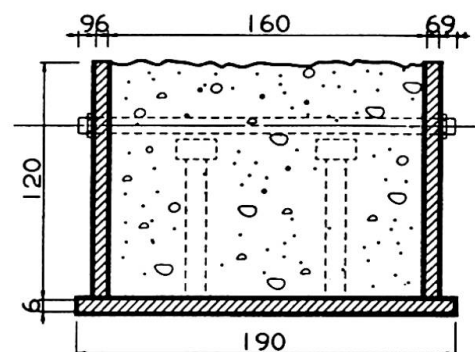
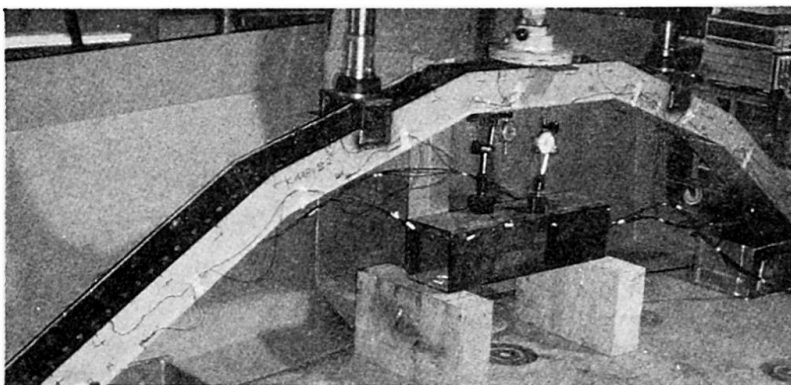

Fig. 1. Loading arrangement and the cross-section of the tested arches.

Test results show a firm behaviour of composite arches to the ultimate load (Fig. 2). The total collapse load of the tested arches was 690 kN and 766 kN, respectively. This means that one arch could easily carry the load of one highway traffic lane. The collapse always occurred near the top section between the horizontal rod stiffeners in such a way that the side walls and the bottom slab of the profile buckled out when concrete was crushed due to compression and shear forces (Fig. 3). A light increase of the deflection and strains was noticed just before the collapse.

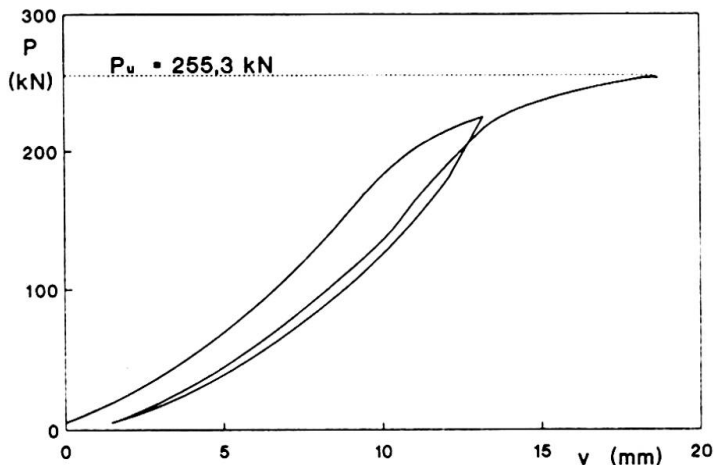

Fig. 2. Mid-span deflection versus load.

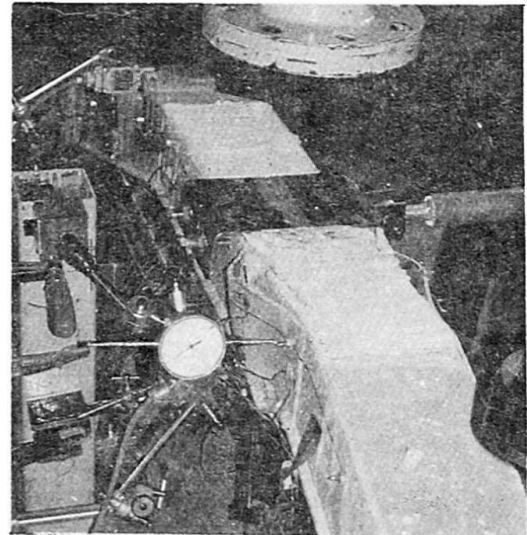

Fig. 3. Typical collapse pattern.

3. APPLICATION

In a recent bridge design competition one proposal, made by a team from the consulting engineering firm Siltatekniikka Oy in Finland, was based on the idea of a composite arch. The span of the arch, which was composed of a steel box filled with concrete, was 260 m (Fig. 4).

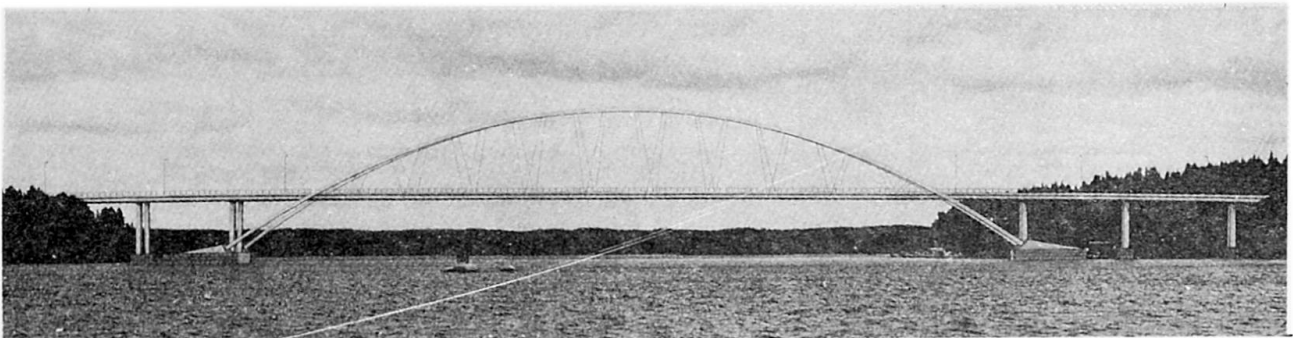

Fig. 4. A proposal for the application of a steel-concrete composite arch.



New Opportunities with Arapree Prestressed Concrete

Béton d'arapree précontraint

Arapree-Spannbeton

Arle GERRITSE
Civil Eng.
Hollandsche Beton Groep
Rijswijk, The Netherlands

Lou HYNA
Civil Eng.
Hollandsche Beton Groep
Rijswijk, The Netherlands

Rolf-Dieter Böttcher
Civil Eng.
AKZO
Wuppertal, Germany

1 Introduction

In recent years extensive research has been carried out into the behaviour of man-made high strength fibres, aiming for structural application in concrete. This paper describes some recent designs and applications of Arapree (ARAmid PREstressing Element) in concrete.

ARAPREE prestressing elements are composed of aramid fibres, embedded in a polymeric matrix, with the following main characteristics: high strength (3000 N/mm^2), non-corrosive, resistant to aggressive environments, excellent fatigue behaviour and insensitive to electro-magnetic currents. The durability of Arapree is even guaranteed in cracked cross-section. For more detailed information, see [1].

2 Applications

2.1 Fish ladder

In The Netherlands a hydro-electro power station has recently been built in the river Meuse. To enable fish to pass the 4,5 m head (difference in water level) a fish ladder was constructed consisting of 24 small weirs. Each weir is composed of vertical driven piles with shutters in between. To allow for optimisation of the water stream over the weirs, the shutters have to be adjustable by hand. They are 35 mm thick and weigh 19 kg. In addition to these elements, the slide near the entrance and the walkway to the control winch are also made of concrete prestressed with Arapree.

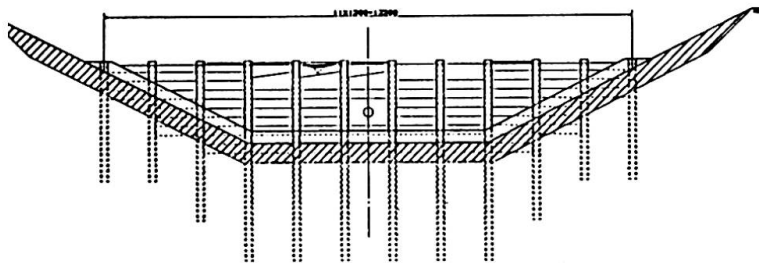

Typical cross-section fish ladder

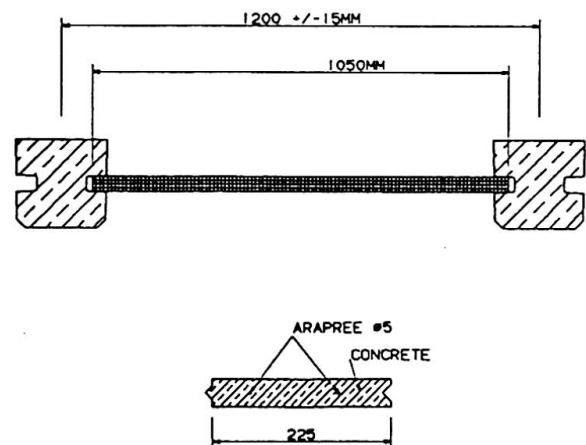

Details

A construction comparable to the weirs is the bank protection. A feasibility study showed that the use of Arapree prestressed concrete elements can be economically more attractive than traditional concepts in steel or wood for a retaining height of 3 m.

2.2 Sun screen

The possibilities of Arapree prestressed concrete require a new way of thinking to utilize the material at its best. A typical example of this is the design of a sun screen for tunnel entrances. Traditionally, these screens are made of aluminum lamellae which are supported by a steel structure. An alternative construction in concrete is not possible due to the large concrete cover. The slightly curved Arapree elements with a rise of 1 m span 12,8 m have a cross-section of 250 mm wide and 90 mm high.

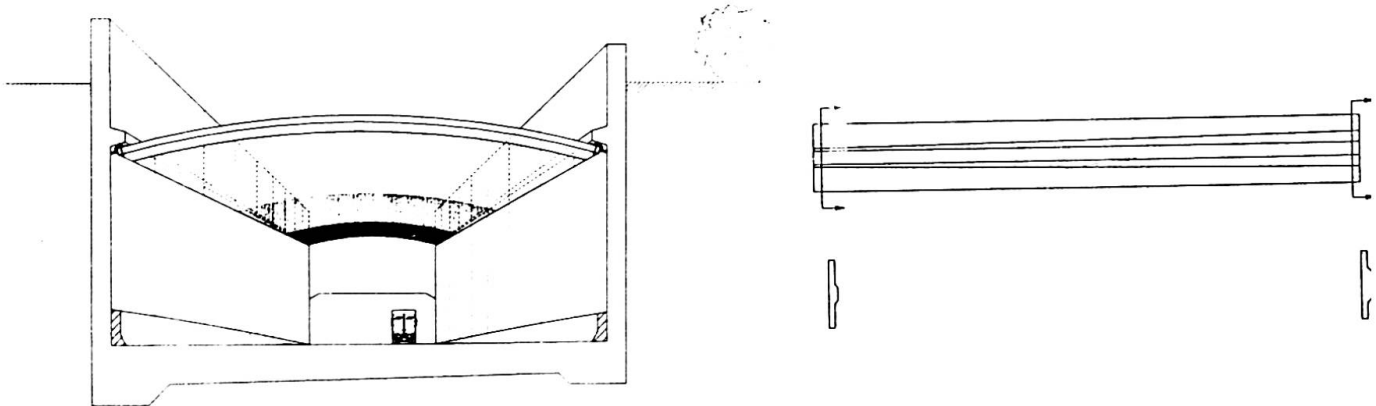

Tunnel entrance

Wall elements

2.3 Wall elements

The eastern entrance of the new tunnel under the river de Noord in the Netherlands is a trough-like structure, founded on concrete foundation piles up to 6.5 m above ground level. To hide these piles from view, a wall of concrete elements along both sides of the entrance is currently under construction. The non-corrosive Arapree made it possible to construct attractive prestressed, light weight elements, in an aggressive environment. The wall elements have a T-shaped cross-section with a width of 500 mm, a flange thickness of 45 mm and a total thickness varying from 125 mm to 65 mm.

2.4 Structural building elements

The demand for handy, slender and durable structural elements is in contradiction with the increasing concrete cover necessary to protect normal reinforcing and prestressing steel in aggressive environments. In this field Arapree solves the problem. For instance prestressed concrete lintels and floor elements with minimal dimensions are architecturally attractive and easy to handle.

3 Conclusion

New prestressing materials like Arapree make it possible to widen the horizon of prestressed concrete. The examples discussed make it clear that by using Arapree, concrete can now economically replace traditional materials such as steel, aluminum and wood. Structures that were not possible before in concrete, now are!

4 References

- [1] Gerritse, A et.al.:
New horizons with Arapree prestressed concrete.
Conference papers: IABSE Congress, New Delhi, March 1-6 1992



Interaktive Computer Graphics in the Analysis of High Rise Buildings

Infographie interactive pour le projet de maisons hautes

Interaktive Computergraphik zur Berechnung von Hochhäusern

B.K. GOYAL

Assist. Dir.
Struct. Eng. Research Centre
Ghaziabad, India

M. SAXENA

Scientist
Struct. Eng. Research Centre
Ghaziabad, India

V.N. JANRODE

Junior Techn. Assist.
Struct. Eng. Research Centre
Ghaziabad, India

1. INTRODUCTION

In recent years there have been major advances in the interactive Analysis and Design of Structures to support the engineering design process. The use of interactive menu driven graphics for defining the structural model, creating numerous input required for analysis, controlling analysis & redesign and interpreting results of analysis distinguishes the interactive analysis & design from conventional analysis and design software[1]. Interactive analysis and design makes sophisticated analysis accessible to practitioners and makes engineering designs creative and innovative. With this in view efforts have been made to develop an interactive graphic pre and post processor for the analysis of high rise building frames. The pre and post processors are menu driven and user friendly. The preprocessor enables the designer to transform a physical model of the structure into a mathematical form in an efficient way. The postprocessor allows the designer to interpret the analysis results and enable to take decision to arrive at efficient and economical design. The number crunching operations such as generation and solution of stiffness matrix, computation of member forces etc. is performed by batch processing. The interactive mode is provided for the processes such as modeling of structure, creating/editing inputs and interpretation of analysis results etc. This enables a sense of creativity to the designer.

2. APPROACH FOR INTERACTIVE ANALYSIS OF HIGH RISE BUILDINGS

A package FRAME3D[2] has been developed by the authors for static and dynamic analysis of 3D high rise buildings with rigid floors as well as for 2D plane frames with or without shear walls. This package was designed to operate in batch mode which requires input in fixed format and results are listed for all structural members. The graphic based interactive modules work as a interface between the designer and main program. With the help of preprocessor data input is simpler and can be checked by the user at every stage minimizing the wastage of man and machine time.. Depending on the Bending Moment and Shear Force diagrams the designer can take quick decision to change the structural member properties.

2.1 Modeling

The menu driven preprocessor module enables the designer to describe the physical model to the computer[3]. This is used to create a structural model and define load conditions for either a static or dynamic analysis. This module makes queries familiar to the user for creating the required input and also avoids data of repetitive nature. A view of typical screen for creating load input is shown in fig. 1. This figure has been plotted on Clacomp 1077 plotter. By using submenus member properties, static and dynamic loads and other parameters are assigned to

the model. The data generated by this module is used directly by the analysis program as input file.

2.2 Analysis

In this main module frames are analyzed using stiffness matrix method. Tridiagonal technique is applied to solve stiffness matrix, requiring minimum core storage[2]. It also computes the member forces and stores results in a file in numerical form.

2.3 Postprocessor

The post processor enables to draw the bending moment, shear force diagram and axial force for the various structural members and load combinations. The bending moment, shear force diagram and deflected shape of the structure can also be plotted on the plotter.

3. CONCLUSION

An interactive graphics menu driven pre and post processor for analysis of high rise buildings have been presented. These modules are developed in FORTRAN 77 on Tektronix 4301 graphic workstation and uses PLOT 10 - IGL graphic library. By using this package a designer can analyze multistorey frames quickly and achieve economical and innovative designs.

ACKNOWLEDGEMENT

This paper is published with the kind permission of the Director, SERC Ghaziabad.

REFERENCES

1. KULKARNI, A.G. and TALPADE, N.V., 'Interactive Integrated CAE Software for RC Framed Buildings, Proceedings 'International Conference on Engineering Software, IIT, Delhi, Narosa Publishers, 1989, pp.49-56.
2. GOYAL, B.K., GUPTA, A.K., AGARWAL, S.K., PREMCHAND and SHARMA, S.P., 'Computer Analysis of Multistoreyed Buildings', International Journal of Structures, Vol.7, No.2, 1987, pp.139-154.
3. CARLOS I. PESQUERA, WILLIAM MCGUIRE and JOHN F. ABEL, 'Interactive Graphical Preprocessing of Three Dimensional Framed Structures', Computers & Structures, Vol.17, No.1,1983, pp.1-12.

No. of Storoyes 2
No. of columns 2

Load Cases Diagram

1. Point Loads
2. Variable Loads
3. Load Combination

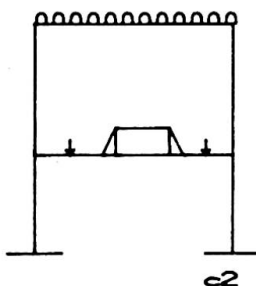



Urea Silos at Hazira, Gujarat

Silos à engrais, Hazira, Gujarat

Düngersiloanlage in Hazira, Gujarat

S.G. JOGLEKAR

Princ. Consult.
STUP Consultants Ltd.
Bombay, India

V.L. DESHPANDE

Joint Princ. Consult.
STUP Consultants Ltd.
Bombay, India

1.0 UREA STORAGE AND HANDLING FACILITIES

The urea handling and storage facility for the gas based fertilizer complex at Hazira, India, is one of the largest constructed in Asia. It consists of a twin horizontal silo having storage capacity of 90,000 tonnes of urea, a 9 storied transfer house structure and approx. 1000 m long conveyor galleries connecting transfer house, silos and bagging plant.

2.0 THE STORAGE SILO

The storage silo consists of twin horizontal silos 195 m x 130 m in plan, which are in the form of two intersecting inverted catenaries joined in the centre with a vertical wall, refer fig. 1. Each catenary has a span of 65.5 m at the springing level and rise of over 33 m. The catenary shape carries the gravity loads like self weight which is the main load in axial compression. The other loads such as load from loading-conveyors at top, wind, seismic and thermal induce bending effects for which the moment of resistance is developed by providing depth of 1.2 m to the folded plate units. These folded plate units having horizontal width of 3.4 m are placed next to each other in a continuous manner to cover the length of 195 m. Thus the same structural unit provides both the longitudinal and transverse spanning system. Each folded plate has inclined webs at 45 Degree which are 70 mm thick while flanges are 100 mm. Extra thickening is provided at the junction of webs and flanges in order to accommodate the main steel which is along the direction of the catenary. A number of longitudinal diaphragms have been provided to ensure the prismatic behaviour of the folded plate.

The loading conveyor at the top is supported on precast inverted portal frames which in turn are connected to the longitudinal stiffening beam connecting the folded plates.

The two end gable walls are independently standing folded plate type of units without top connections to the shell.

2.1 Foundation

Detailed soil investigation indicated a very expansive type of clay in the top layers. Space restriction precluded taking foundation below these layers. It would have also increased the span and the cost of the structure. Therefore the expansive soil was replaced by properly compacted and confined river sand and used as a foundation strata.



The twin arches are supported on the three continuous strip footings. Freyssinet hinges are introduced between the shell and all the three strip footings, which avoids secondary bending effects.

3.0 CONSTRUCTION SCHEME

Fig. 2 shows the precast units of folded plates being placed on the temporary steel arches. A unit of 24 m x 130 m of silo was thus covered by pre-cast units which are connected together by cast-in-situ high-strength concrete which permitted early decentering. The longitudinal and transverse reinforcement projecting from the pre-cast shells was field welded. Field welding of these HYSD bars was a major and tedious job requiring close supervision since the structural continuity depends on this operation. Each such unit was completed in 4 weeks. The supporting arches were then moved forward on rails for casting of next unit of 24 m length.

4.0 OTHER STRUCTURES

Transfer house which is a 9 storied structure with 5000 sq. m builtup area is of cast-in-situ construction. The 1000 m long conveyor galleries are supported on 4 column trestle units over which precast longitudinal beam and flooring and precast portal frame units covering the conveyors on all sides are erected.

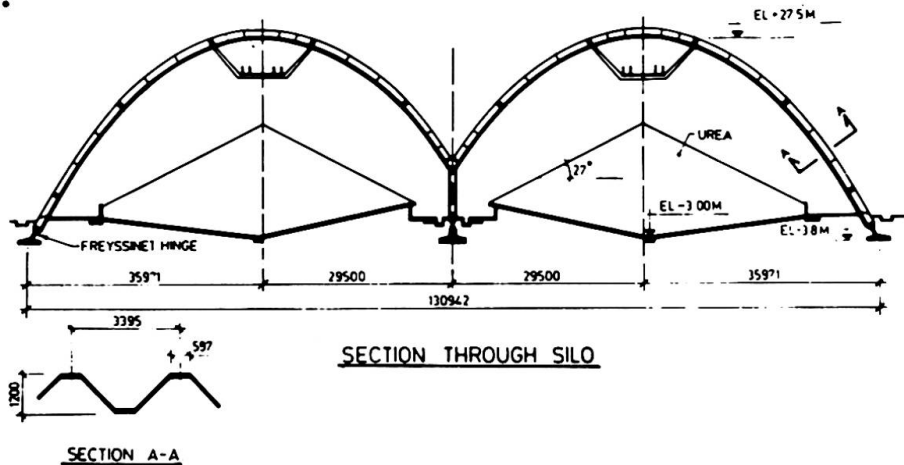

Fig.1 Section through Silo

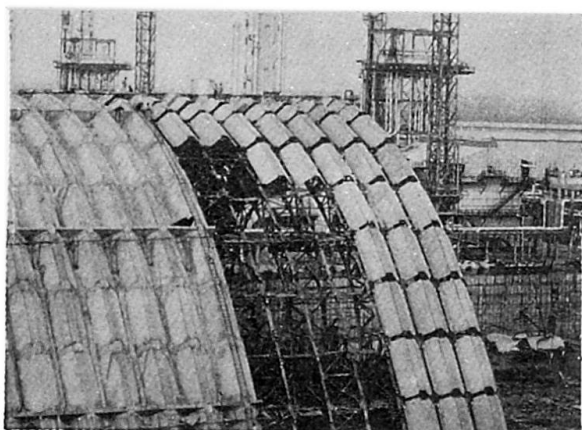

Fig.2 Preparation of a typical 24 m unit for in-situ connection

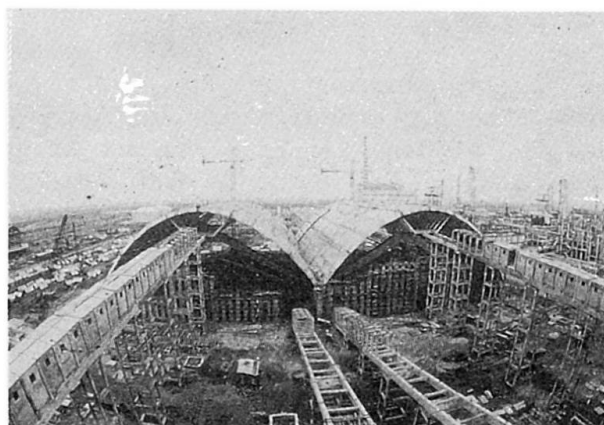

Fig.3 Silos & Conveyor Galleries



Legislative Assembly Hall at Gandhinagar, India

Bâtiment de l'assemblée législative à Gandhinagar, Inde

Parlamentsgebäude in Gandhinagar, Indien

S.G. JOKLEKAR

Princ. Consult.
STUP Consultants Ltd.
Bombay, India

J.S. PADALKAR

Princ. Consult.
STUP Consultants Ltd.
Bombay, India

An architect's daring vision becomes concrete reality in the Legislative Assembly Building at Gandhinagar, Gujarat. This five storied circular building springing above the podium level forms a central core around which the Ministerial and Legislative Offices are built and are connected to the core by number of bridge-links on four sides (Fig.1). Exposed structural forms have been used to achieve the architectural effects. The 42 metre diameter structure is supported on eight numbers of main 'V' shaped columns going to the full 40 m. height of the structure, the central column going upto the 2nd floor supporting assembly floor, and four other columns stopping below the podium level. Viewed from the podium level (Fig.2), the main central column rises from the centre of the foyer into radiating, reinforced concrete, rib-beam pattern, to form a delicate stylised flower (Fig.3). The main assembly floor supported on eight 'V' columns and the central column seats 232 legislators under the central octagonal dome. The eight surrounding galleries provide for the officials, the press and upto 600 visitors (Fig.4). The galleries spanning between 'V' columns are inverted folded plate units following the shape of the gallery in form of inverted two sides of a triangle. Door openings have been cut in this structural shape at the lower end of the gallery at different locations on eight sides. Surrounding space cantilevering from assembly floor beyond 'V' columns forms circulating space for legislators. Similar cantilevering circulating space at 3rd floor level serves the galleries avoiding intermixing of legislators and the visitors.

The octagonal floating dome (Fig. 4) is supported on eight brackets cantilevering from the 'V' columns with gaps on all sides to permit natural lighting, augmenting light from central skylight (Fig. 5). This gap gives a vision of the floating dome. The 'V' columns penetrate beyond the peripheral roof slab and have cantilevered beams extended upto central skylight creating an effect of a dome suspended from these over the assembly hall as seen from the roof level.

The parking, canteen services and maintenance facilities are provided on Ground Floor. The air conditioners for assembly hall are fitted into triangular rooms enclosed within 'V' shape columns at the roof level. The space in the crook of 'V' columns forms ducts for air conditioning. Single source of artificial luminaires fitted on top of the domes illuminates the entire floor and the galleries. Except the acoustic treatment of the dome and a few partition walls most of the surfaces are of structural concrete finish, making a complete fusion of the architecture and structure.

The design and analysis of this complex structural framing was carried out using combination of 3-D frame and shearwall effects provided by 'V' columns

performing both dynamic and static analysis. The end structure is extremely light and economical. If total concrete used is spread uniformly over the floor area constructed, it will be of 180mm thickness.

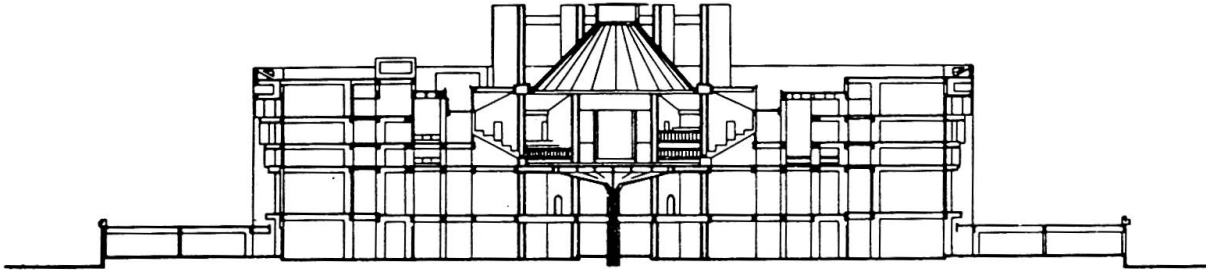

Fig.1 Section through Assembly Hall

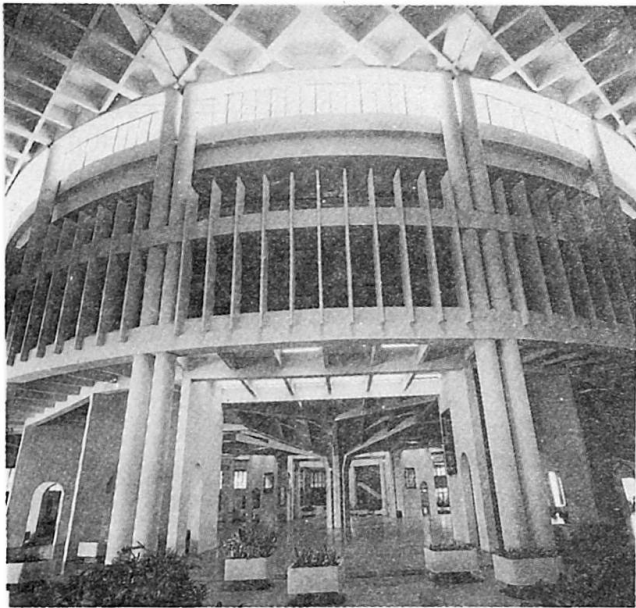

Fig.2 View from Podium Level



Fig.3 Central Column

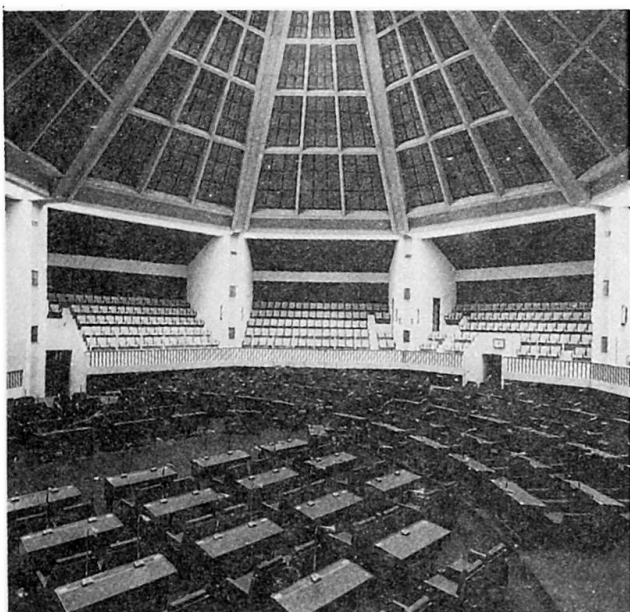

Fig.4 Assembly Floor & Galleries

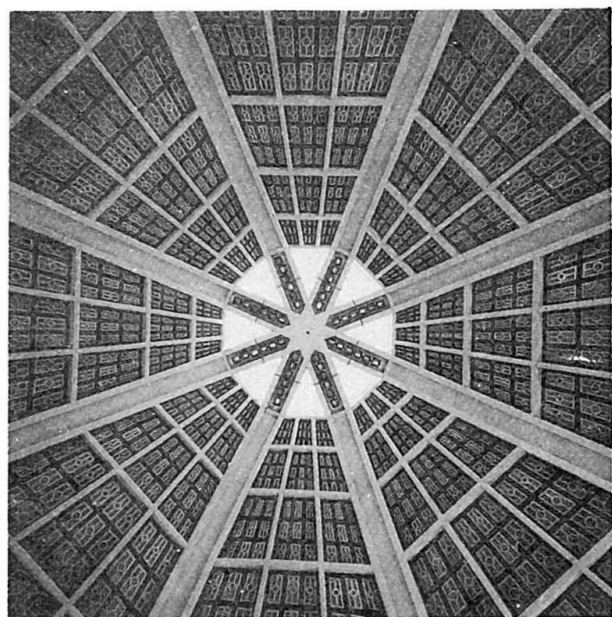

Fig.5 Dome Roof



Containment Slab of Narora Atomic Power Project, India

Dalle pour l'enceinte du réacteur nucléaire de Narora, Inde

Druckbehälterdecke beim Narora Kernkraftwerk, Indien

S.G. JOKLEKAR

Princ. Consult.
STUP Consultants Ltd.
Bombay, India

1. THE PROJECT AND THE CHALLENGE

The containment structure of Narora Atomic Power Project is the prototype of this series of 235 MWe PHWR reactors. In all four such containments at two sites have been constructed and tested. The containment design is based on the double containment philosophy with inner containment in PSC and outer containment in RCC (Fig.1) A special feature of this containment is the provision of flat slab on top of cylindrical walls on which the main steam generators (SGs) are supported. They are partially inside the containment in which portion the radioactive primary heat transfer systems are located and project outside the containment in which portion the light water/steam circuits are located. Apart from SGs several equipment are located on this slab which require large number of embedded steel parts. This unusual arrangement has put number of functional and behavioural demands on the containment slab much beyond its function as pure containment. A highly innovative solution has been evolved to meet this challenge.

2. THE SOLUTIONS

2.1 Minimum Weight in High Seismicity Zone

The Design Basis Earth-quake has peak acceleration of 0.3g at ground level and of about 1.0g at slab level. A cellular slab solution was therefore evolved which has a low mass to strength ratio.

2.2 Support for Steam Generators

SGs are mainly supported on containemnt slab. The functional requirement demanded no relative movement between SG and inner reactor building, whereas the slab has a relative deflection with respect to internals. Specially designed spring supports were developed in such a way tht the relative position of SG and the internal structures does not change and the deflection of containment slab relative to SG's is absorbed by the variation in spring length without modifying reactions appreciably.

2.3 Choice of Composite Construction

More than 250 t of embedded parts are provided in the top of the containment slab, the locations of which were inflexible. Thus prestressing cables could not be located in any practicable way in the top slab and the containment slab had to be designed as a RCC structure for resisting upward pressure. On the

otherhand to give a leaktight containment boundary the lower slab was prestressed separately before casting of the webs and top slab by orthogonally placed cables. By this method creation of negative moments in the containment slab by eccentrically placed cables was avoided and thereby the requirement of prestressing was also minimised.

2.4 Monolithic Connection to Outer Containment - Design & Construction Aspects

A large difference in downward self-weight of 4.5 t/m^2 and upward pressure of 14.4 t/m^2 combined with seismic amplifications under vertical excitation would have required higher structural depth and more massive slab. To reduce the net effect of both of these factors the cellular slab was connected to outer containments so that the inner and outer containments together provide substantial fixity effects to containment slab, thus achieving more favourable distribution of bending moments. However, for constructional purpose it was not possible to link up sequencing of outer containments with that of containment slab. Hence the containment slab was designed to span as simply supported slab on inner wall alone carrying its self weight and then subsequently connected to outer containment by means of RCC connections. This decision gave additional advantage of inducing larger positive bending moments at the centre of the slab requiring upward pressure more than the equivalent self weight to nullify the pre-compression thereby resulting in reduction of reinforcement.

2.5 Construction Sequence and Flexibility

The bottom slab was cast in panels on the full staging and prestressed. RCC webs and top slab were also cast on staging. The composite slab was decentered carrying its full self weight which is supported on I.C wall. The connection with outer containments was concreted subsequently. The total construction period was 12 months.

The shrinkage/creep time histories of IC wall, OC wall, bottom prestress slab, RCC webs and top slab, RCC connection between IC and OC are all different. The exact analysis accounting for these histories was carried out for 2 or 3 construction sequences thereby permitting flexibility in the planning of the construction activity. This slab under construction is shown in fig. 2.

2.6 Testing Facility

Provision is made for positive pressurising of cellular volume to enable location of any leaks across the prestressed bottom slab from below. This is required since the cellular volume is not accessible for inspection during main leak testing when inside of the containment is pressurised.

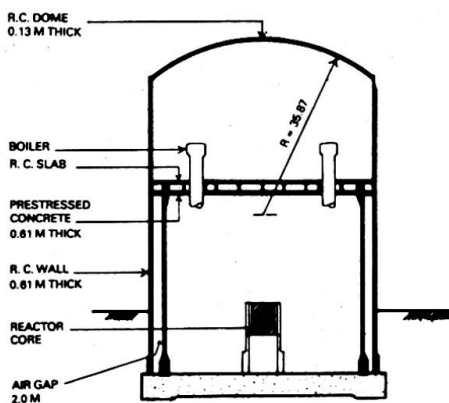

Fig. 1 Cross Section

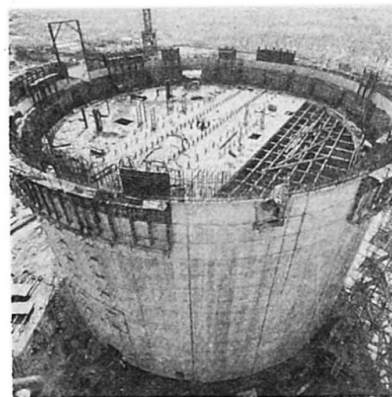

Fig. 2 Containment under Construction



Building System Based on Demountable Sheet Steel Elements

Système de bâtiments utilisant des tôles d'acier démontables

Demontables Wohnungsbausystem aus Stahlblechelementen

J.O. BATS

Assoc. Prof.

Eindhoven Univ. of Technology

Eindhoven, The Netherlands

Research was started some years ago, in Eindhoven on the considered possibility of using sheet-steel elements in housing and before long the idea of industrialization was being considered. It has resulted in the development of a steel bearing system as the main part of what Prof. N.J. Habraken calls as a "support" in house building. This system has three essential points:

- Industrialization by design-independent mass production of relatively small elements for loadbearing and infill systems,
- Occupant's wishes as to layout and finish can be met,
- Optimal use is possible of CAD-CAM in design, production and logistic management.

The essence of the bearing system is the element shown in figure 1a₂. These elements are used both horizontally and vertically in two widths: 600 mm and 1200 mm (fig. 1a₁).

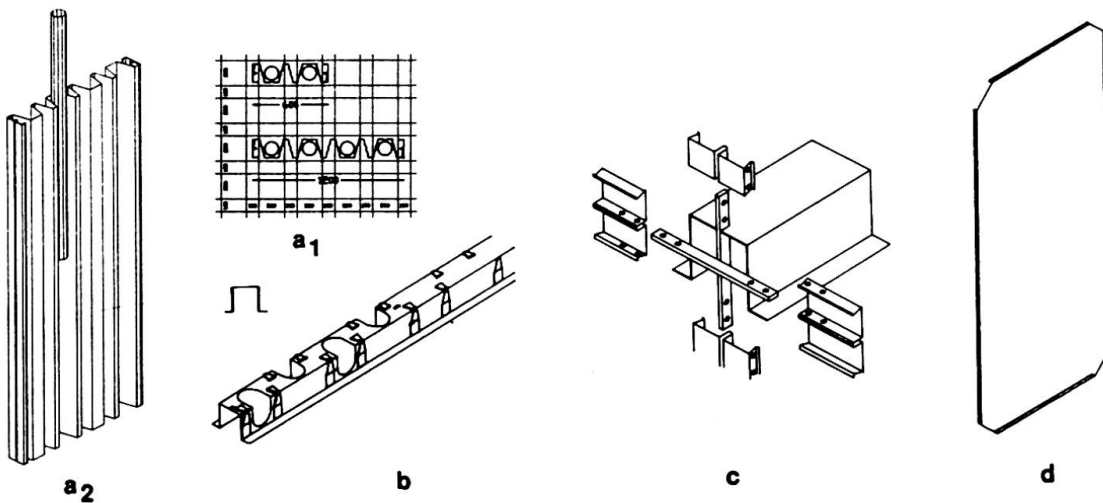

Fig. 1

Steel bearing elements of this kind, together with a so-called "hat profile" (fig. 1b) form the "bearing structure" of the support. The "hat profile" allows the positioning and connection of the horizontal and vertical elements of the bearing structure. Therefore, small parts are spotwelded on the outer and upper sides of the "hat". For securing horizontal and vertical coherence, coupling strips are needed, as given in fig. 1c. The "house of cards" still requires stability provisions in the form of steel-sheet shear walls in the transversal direction. These walls are suitably placed, parallel to the front and back façades of the building (fig. 1d). So that the steel bearing system can form a support, it has to be clad with subsystems for the floating floor, prepositioned wall panel and the ceiling (fig. 2), all developed as design independent subsystems.

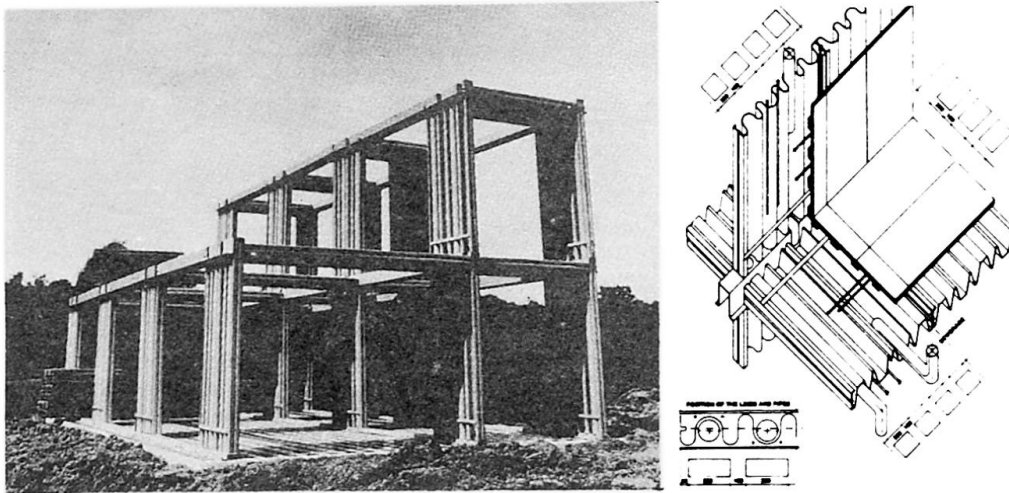
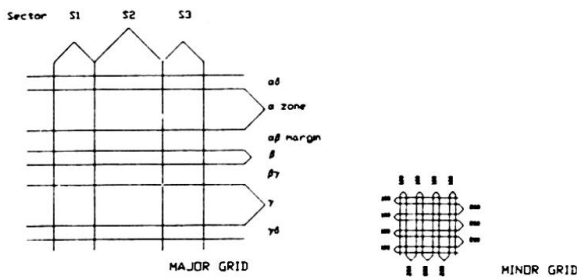

Fig. 2

A house design has not been used for the development of this system but a stylization of that developed by Prof. Habraken in his design method.



This includes the use of 2 tartan grids, namely:

- a major grid, determining zones, margins and sectors for occupancy functions,
- a minor grid of 100 and 200-mm bands, based on 300 mm.

The lines of the major grid coincide with the centre lines of the 100-mm bands of the minor grid.

Together, these two grids enable the development of design-independent components, within a very exactly defined system of agreements on placing and dimensions. These components can be applied in all designs that can be made in the major grid, where there is freedom of choice in the α , β and γ zones, as well as in the sectors S_1 , S_2 etc. In all, the bearing structure consists of 14 different elements, demonstrating the effect of this method of handling the problem. With this very small number of different elements a wide range of bearing structures can be built.

For all subsystems, except those known as mechanical, seven in all, on the same principle, efforts are made in this project to cover a maximum of layouts with few different elements. (See the paper of J.F.G. Janssen: Design Strategy for an Industrialized Building System).

Some subsystems need less than 14 elements, others require a few more; so that calculating an average of 15 for each, we have ± 100 different components, with which a great diversity of dwellings can be built.

Even if we had miscalculated by 500% we would then need about 500, which is still only 10% of the 5000 different elements necessary in the Japanese Steel Housing System [4].

Literature References:

- [1] Habraken, N.John, "Three r's for housing", Scheltema en Holkema, Amsterdam 1970
- [2] Article by Kendall and Sewada, "Changing pattern in Japanese Housing", Open House Ing. Vol. 12, No. 2, 1987
- [3] Habraken, N.John, "Transformations of the Site, Awater Press, Cambridge, Mass. 1983
- [4] Togo, T., "Industrialised housing in Japan: steel-frame prefabricated houses, 20 I.I.S.I. Conference, Rio de Janeiro 5-8 October 1986.
- [5] Bats, J.O. and Janssen J.F.G., "Industrialized Housing with sheet-steel elements", Ninth International Specialty Conference on Cold-Formed Steel Structures, St. Louis, Missouri, U.S.A., November 8-9, 1988



Design Strategy for Industrialized Building System

Stratégie pour la conception d'un système de bâtiments industrialisés

Entwicklungsstrategie für eine industrialisierte Bau konstruktionsart

J.F.G. JANSSEN

Ing., Archit.

Eindhoven Univ. of Technology

Eindhoven, The Netherlands

The Industrial load bearing system for housing based on (de)mountable sheet-steel elements "STRUCTURE" developed by ir. J.O. Bats at the Eindhoven University of Technology forms a very precise and dimensionally stable environment, based on the principle of modular coordination, so that the finishing systems can be industrially produced with predictable tolerances and fitting components.

In addition to "STRUCTURE", we can distinguish another three main systems for finishing the building namely: "ENVELOPE" (subsystems: façade, roof), "INTERIOR" (subsystems: floor, ceiling, prepositioned and partition walls), "MECHANICAL" (subsystems: electricity, gas, water, central heating supplies, sewerage and communication).

The main conditions for developing these four main systems: structure, envelope, interior and mechanical are: (1) industrial production, (2) (de)mountable at all levels, (3) flexibility in use and (4) suitability for an open building system.

In order to develop of these four main systems, it is necessary to specify:

1. their place within a modular grid,
2. the building sequence,
3. the level of integration of the connections between the building components,
4. the technical requirements of the systems and their connections.

Ad 1. the location of every building component in the four main systems is defined by the same particular tartan grid based upon a 300 mm grid.

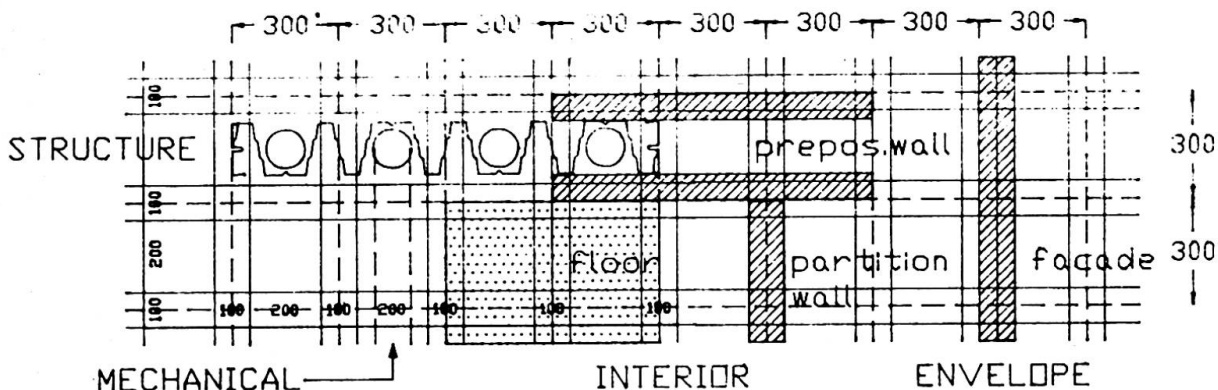

Ad 2. the building sequence of the three finishing systems: interior, envelope and mechanical, is also prescribed by scenario alterations for guaranteed flexibility in use and with different lifespans of the building components in mind. Accessibility of the piping systems is important in this respect.

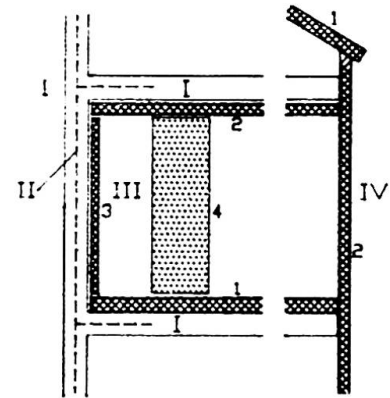
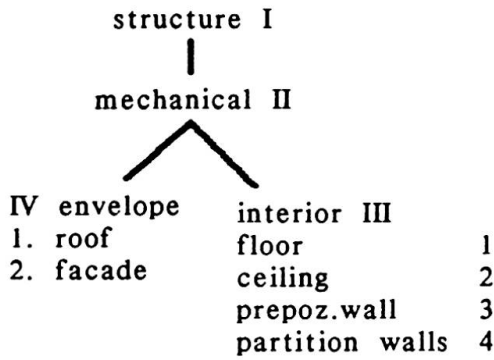

Ad 3. The connections between the building components are divided into five categories: remote (no direct relation), touching, connected, meshed and unified. In this sequence, five levels of integration are indicated. The required level of integration of connections was approximated from a case study of planning an alteration from one spatial layout of a dwelling to another, for which considerable less building time is needed, if the connections between building components are as contiguous as possible and the building materials within a subsystem are to be as "unified" as possible, to ensure easily manageable building components.

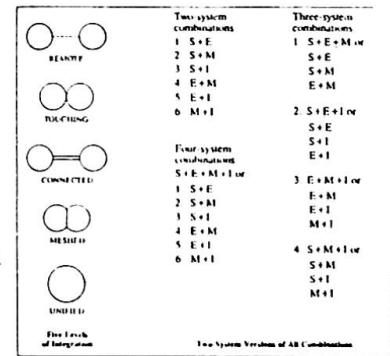

Ad 4. In addition to theoretical fire-protection, acoustics and strength requirements research is in progress on an experiment, scale 1:1 to test the building components in combination with each other in the field of fire protection, acoustics, handling and utility.

After describing the building components of the four systems it is relatively easy to make design studies and calculations of the projects by using CAD.

This includes:

- all the components of the load-bearing system structure
- all the components of the subsystems, such as:
 floor - ceiling prepositioned walls and partition walls interior
 façades and roofs envelope
- all those of the installations mechanical
- and all the agreements on modular coordination between the systems.

These libraries become now related to each other in a special tablet within Autocad.

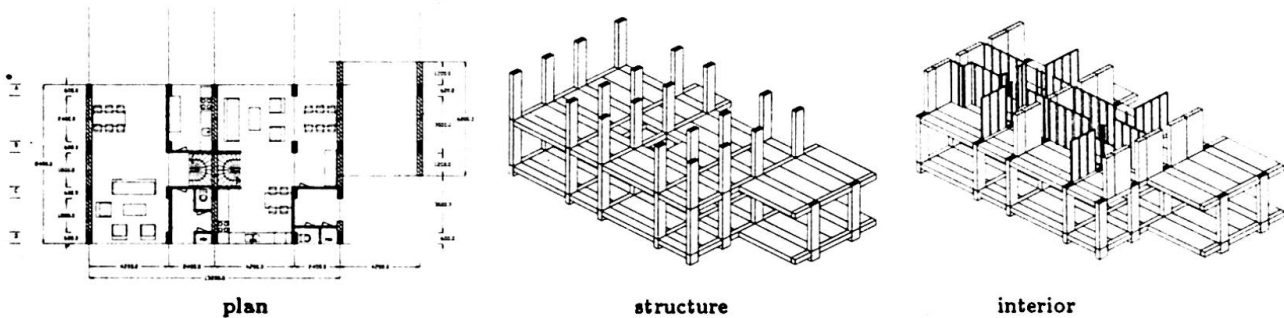

References

1. Rush, the building System Integration handbook, the American Institute of Architects, 1988
2. Kantelberg, B.M.F., Optimalisatie van de variabiliteit van een componenten bouwsysteem (case study) (in Dutch) Afstudeerrapport T.U.E. 1991
3. Bats, J.O., Janssen, J.F.G., a new concept for Industrialized Housing. Proceedings IFHP-international congress, Chiba, Japan, IFHP 1989, pp. 35 - 42.

Leere Seite
Blank page
Page vide