

On the interdependence between the direction of a force and certain mechanical functions, such as reactions, axial forces, bending moments, etc.

Autor(en): **Bryla, Stephen**

Objektyp: **Article**

Zeitschrift: **IABSE publications = Mémoires AIPC = IVBH Abhandlungen**

Band (Jahr): **2 (1933-1934)**

PDF erstellt am: **11.09.2024**

Persistenter Link: <https://doi.org/10.5169/seals-3390>

Nutzungsbedingungen

Die ETH-Bibliothek ist Anbieterin der digitalisierten Zeitschriften. Sie besitzt keine Urheberrechte an den Inhalten der Zeitschriften. Die Rechte liegen in der Regel bei den Herausgebern.

Die auf der Plattform e-periodica veröffentlichten Dokumente stehen für nicht-kommerzielle Zwecke in Lehre und Forschung sowie für die private Nutzung frei zur Verfügung. Einzelne Dateien oder Ausdrucke aus diesem Angebot können zusammen mit diesen Nutzungsbedingungen und den korrekten Herkunftsbezeichnungen weitergegeben werden.

Das Veröffentlichen von Bildern in Print- und Online-Publikationen ist nur mit vorheriger Genehmigung der Rechteinhaber erlaubt. Die systematische Speicherung von Teilen des elektronischen Angebots auf anderen Servern bedarf ebenfalls des schriftlichen Einverständnisses der Rechteinhaber.

Haftungsausschluss

Alle Angaben erfolgen ohne Gewähr für Vollständigkeit oder Richtigkeit. Es wird keine Haftung übernommen für Schäden durch die Verwendung von Informationen aus diesem Online-Angebot oder durch das Fehlen von Informationen. Dies gilt auch für Inhalte Dritter, die über dieses Angebot zugänglich sind.

ON THE INTERDEPENDENCE BETWEEN THE DIRECTION OF A FORCE AND CERTAIN MECHANICAL FUNCTIONS, SUCH AS REACTIONS, AXIAL FORCES, BENDING MOMENTS, ETC.

DIE BEZIEHUNG ZWISCHEN EINER KRAFTRICHTUNG UND
GEWISSEN MECHANISCHEN FUNKTIONEN, WIE AUFLAGERKRÄFTE,
AXIALKRÄFTE, BIEGUNGS MOMENTE USW.

LA RELATION ENTRE LA DIRECTION D'UNE FORCE ET CERTAINES
FONCTIONS MÉCANIQUES, TELLE QUE LES RÉACTIONS, LES
EFFORTS LONGITUDINAUX, LES MOMENTS FLÉCHISSANTS, ETC.

STEPHEN BRYLA, Doctor of Engineering, Professor at the Technical University,
Lwów, Poland.

A concentrated force P is applied at a certain point F of an elastic system and is acting at an angle α to the horizontal. It causes certain deformations and tensions in different points of the system. Certain axial forces, transverse forces and bending moments arise in imaginary sections. Reaction is exercised on the system at its bearings or joints.

All the above-mentioned values are functions of the force P and of the angle α . Some of them (e. g. reactions of fixed bearings) are vectors, i. e. they are determined by tension and direction. Others are determined by tension and sign (e. g. components of reaction in a certain direction, displacements in certain directions, axial forces in rods, transverse forces in certain sections, bending moments about a certain axis).

Such values with a variable direction may be resolved into two components having two freely established directions and their study may therefore be limited to the study of functions with a constant direction.

Such a value will be called effect. There are a great many of such effects, for instance S . For a given P , S is a function of α :

$$S = f(\alpha)$$

Let us take two directions of action of the force, at right angles to one another, viz. the vertical direction, $\alpha = 90^\circ$, downwards, and the horizontal direction from right to left, $\alpha = 0$, and resolve the force P into two components (Fig. 1).

$$H = P \cos \alpha \quad (1)$$

$$V = P \sin \alpha \quad (2)$$

If only the horizontal component is acting, the result will be

$$S_h = \lambda \cdot H \quad (3)$$

If only the vertical component is acting, it will be

$$S_v = \lambda \cdot V \quad (4)$$

presuming the proportionality of cause and effect i. e. of the law of superposition. κ and λ are coefficients of proportionality. If the effect S has the same dimension as the force, then κ and λ have no dimension at all. Their dimension may be obtained in general, from equations (3) and (4).

In view of the fact that the forces H and V are acting simultaneously, we have according to the law of superposition

$$S = S_h + S_v \quad (5)$$

Introducing equations (3) and (4) into (5), the result is as follows: (taking into consideration the formulae (1) and (2))

$$S = P(\kappa \cos \alpha + \lambda \sin \alpha) \quad (6)$$

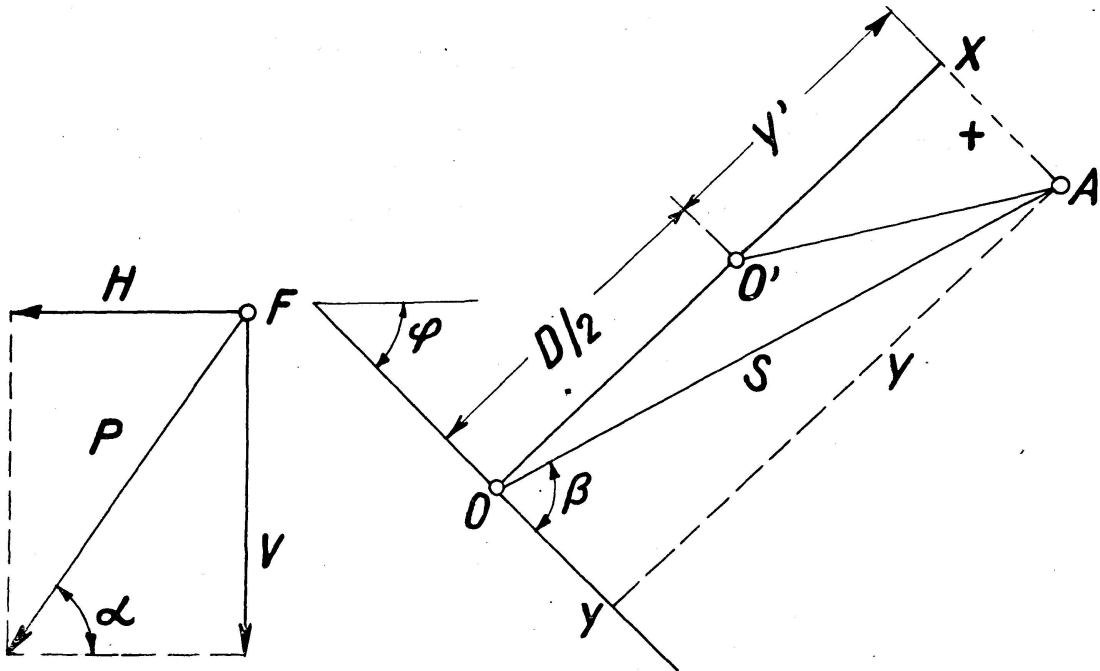

Fig. 1.

Fig. 2.

Let us say:

$$\frac{\kappa}{\lambda} = \tan \varphi = t \quad (7)$$

$$\text{then } \sec \varphi = \sqrt{1 + t^2}, \quad (8)$$

$$\text{or } \sec \varphi = \frac{1}{\lambda} \sqrt{\kappa^2 + \lambda^2} \quad (9)$$

$$S = P \lambda \varrho \quad (10)$$

besides

$$\varrho = \sin \alpha + \tan \varphi \cos \alpha = \sec \varphi (\sin \alpha \cos \varphi + \cos \alpha \sin \varphi) = \sec \varphi \sin(\alpha + \varphi)$$

Introducing this formula into (10), and taking into consideration the formula (9),

$$D = P \sqrt{\kappa^2 + \lambda^2} \quad (11)$$

$$S = D \sin(\varphi + \alpha) \quad (12)$$

S changes dependently on α , along the sinusoid.

If $\beta = \alpha + \varphi$

$$\text{then } S = D \sin \beta \quad (13)$$

circle. We displace the triangle $AC'B$ until the diameter AB is vertical; the side AC' will then become the radius which had to be obtained, and it appears that C' lies on the circumference of a circle of diameter D . The

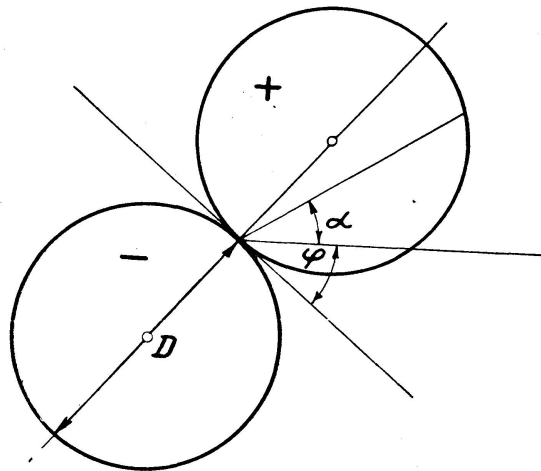
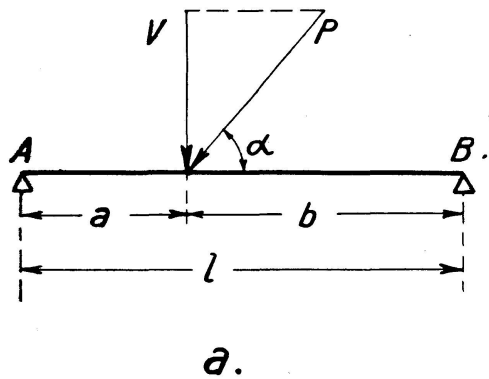

Fig. 5.

relation between S and β in polar coordinates is determined by a circle tangential to the axis OX (Fig. 2) inclined to the vertical line at the angle φ . If $\beta < 0$, or $\beta > \pi$, then $S < 0$. A second circle corresponds to the negative values of S ; this circle is situated on the opposite side of the axis OY , which is tangential to both circles (Fig. 5). Thence the following general law:



a.

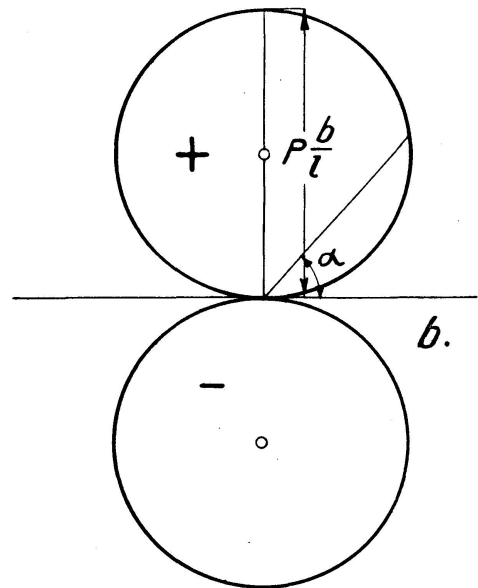

Fig. 6.

When in a given system the law of superposition can be applied, any mechanical function (force in rods, bending moment, transverse force, tension) characterized by tension and sign and caused by the force P , acting at a certain point at an angle α to the horizontal, can be expressed by polar coordinates $S = f(\alpha)$ in the form of two circles tangential to each other externally and with the same diameter D , whereby $D = S \max$.

Examples:

1. Girder on two supports (Fig. 6a).

$$\text{Reaction of the support } A = V \frac{b}{l} = \frac{a}{l} P \sin \alpha.$$

For $\alpha = \frac{\pi}{2}$, $A \text{ max} = \frac{b}{l} P = D,$

therefore $A = D \sin \alpha$ (Fig. 6b).

The bending moment at the point of application of the force P is $M = A a = D' \sin \alpha$, if $D' = D a$. Figure 6 b is to be reckoned here as well but on a different scale, in which $D = D'$. The moment at a certain point of the girder (Fig. 6 a) as well as the transverse force and the deflection are also expressed according to α , on a corresponding scale fig. 6 b.

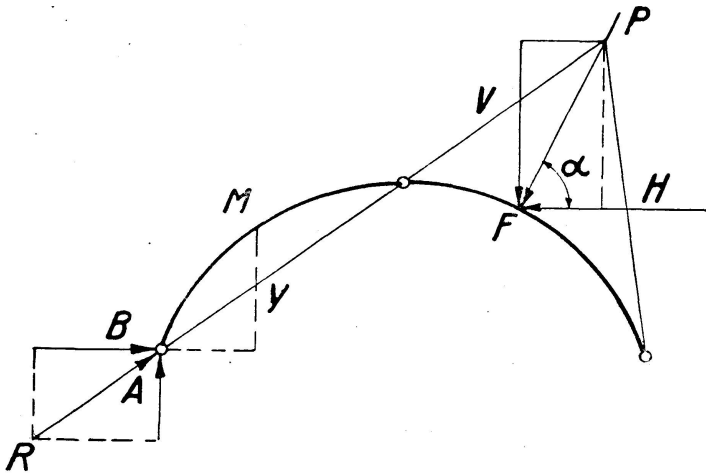

Fig. 7.

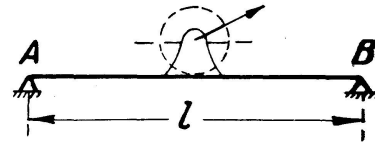

Fig. 8.

2. Three-hinged arch (Fig. 7).

We shall consider the bending moment in the section $M(x, y)$ as an effect of the force P , applied at a certain point of the right half of the arch. This moment depends upon the lefthand reaction R . Its vertical component is

$$A = \lambda' H + \lambda' V.$$

The horizontal component

$$B = \lambda'' H + \lambda'' V,$$

besides which,

$$H = P \cos \alpha$$

$$V = P \sin \alpha$$

and λ', λ'' and λ', λ'' are corresponding coefficients of proportionality. According to Fig. 7:

$$M = Ax - By.$$

Introducing the angles φ' and φ'' as per equations:

$$\tan \varphi' = \frac{\lambda'}{\lambda''} \quad \tan \varphi'' = \frac{\lambda''}{\lambda'}$$

it follows that

$$\begin{aligned} A &= P(\lambda' \cos \alpha + \lambda' \sin \alpha) \\ &= P \sqrt{\lambda'^2 + \lambda''^2} \cdot \sin(\alpha + \varphi') \end{aligned}$$

and

$$B = P \sqrt{\lambda''^2 + \lambda'''^2} \cdot \sin(\alpha + \varphi'')$$

Therefore

$$M = P \cdot [x' \sin(\alpha + \varphi') - y' \sin(\alpha + \varphi'')] \quad (a)$$

besides which,

$$\begin{aligned} x' &= x \sqrt{\lambda'^2 + \lambda''^2} \\ y' &= y \sqrt{\lambda''^2 + \lambda'''^2} \end{aligned}$$

But

$$\begin{aligned} \sin(\alpha + \varphi') &= \sin \alpha \cos \varphi' + \cos \alpha \sin \varphi' \\ \sin(\alpha + \varphi'') &= \sin \alpha \cos \varphi'' + \cos \alpha \sin \varphi'' \end{aligned}$$

and as per (a)

$$\frac{M}{P} = \lambda''' \cos \alpha + \lambda'' \sin \alpha$$

besides which,

$$\begin{aligned} \lambda''' &= x' \sin \varphi' - y' \sin \varphi'' \\ \lambda'' &= x' \cos \varphi' - y' \cos \varphi'' \end{aligned}$$

Finally

$$M = P \sqrt{\lambda''^2 + \lambda'''^2} \cdot \sin(\alpha + \varphi''') \quad (b)$$

if

$$\tan \varphi''' = \lambda''' : \lambda''$$

We have then obtained here also the formula (b) in accordance with the equation (12).

Conclusions:

1. Any mechanical function M in a certain system has the property that for every point of application of the force there are two directions at right angles to each other, such that when the force is acting in one of these directions $M = 0$, and when it is acting in the other $M = \max$.

2. If a certain mechanical function is equal to 0 for a certain angle α , it is also equal to 0 in the opposite direction $\alpha = \pm 180^\circ$. When $\alpha = \pm 90^\circ$ it reaches its maximum.

3. For any point of the system and for a certain mechanical function of this system, there exists always one direction of the force for which this function equals 0. The same applies to the directly opposite direction. For directions at right angles to each other, the function reaches its positive or negative maximum respectively. There cannot exist two directions not at right angles to each other, for which the mechanical function M would equal 0 and the maximum respectively.

4. If a force of constant value and variable in direction is acting at a certain point of a girder or of a mechanical system (Fig. 8), it causes in all mechanical functions of this system, having a constant direction, alterations from 0 to + max and from + max to 0, then from 0 to - max and from - max to 0, with every complete rotation of the direction of the force.

Examples of application.

Example 1. To determine S max, when P is acting at C (Fig. 9 a). When the force P is acting on CB , then $S = 0$. When the force P is acting on AC , then $S = P$.

$C'B' \parallel CB$ and $C'A' \parallel CA$ are drawn from an arbitrarily chosen point C (Fig. 9 b). $C'A' = P$ and the circle $C'A'D'$ tangential to $C'B'$ is drawn through the points C' and A' . The vertical line $C'D'$ at right angles to $C'B'$ gives S max.

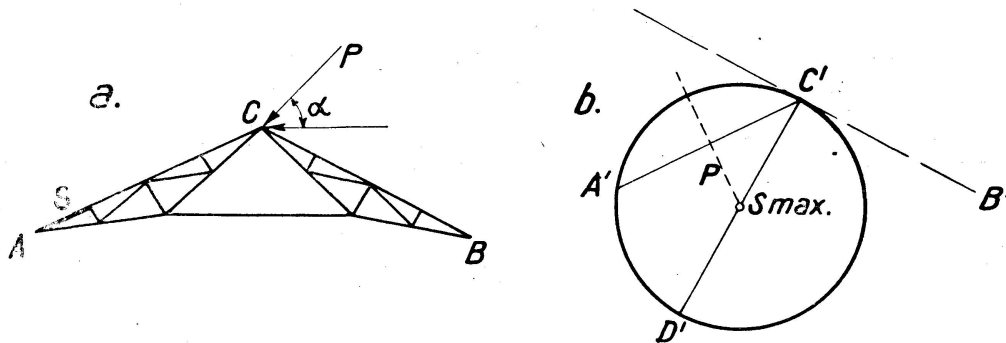

Fig. 9.

Example 2. To determine the internal stress in the diagonal k of the lattice girder, when the force $P=1$ is applied at C and has the direction shown on Fig. 10 a:

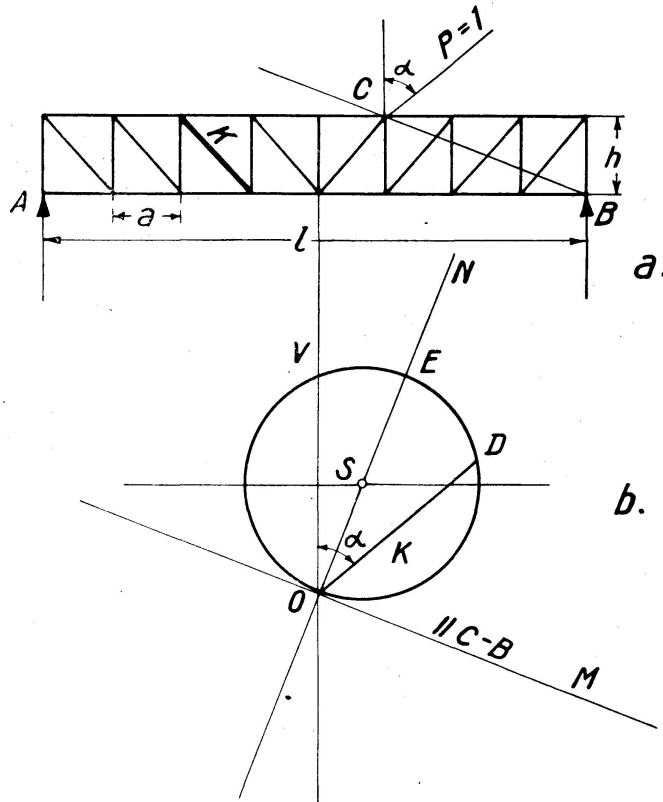

Fig. 10.

Given $l = 24$ m, $h = 3,6$ m, $a = l/8 = 3$ m.

The length of the diagonal is $k = \sqrt{3^2 + 3,6^2} = \sqrt{9 + 12,95} = \sqrt{21,95} = 4,69$ m.

When $P_v = 1$, then $A_v = \frac{3}{8}$.

$$K_v = A_v \frac{k}{h} = \frac{3}{8} \cdot \frac{4,69}{3,6} = 0,489.$$

From an arbitrarily chosen point O (Fig. 10 b) a vertical section $OV = K_v = 0,489$ and straight lines $OM \parallel CB$ and ON at right angles to CB are drawn.

The axis of symmetry of the section OV cuts ON at the centre of the circle S . The chord $OD \parallel P$ gives the internal stress $OD = K$ in the diagonal corresponding to the direction of the force P . At the same time it can be seen that $K = \max = OE$, when the force $P = 1$ acts vertically to CB .

Example 3. A semicircular three-hinged arch of radius r . The force P is applied at D (Fig. 11), where the inclination of the normal is 45° to the horizontal. To determine the maximum moment in D and E ($\alpha = \frac{45}{2}$), (Fig. 13) and the corresponding directions of the force $P = 1$.

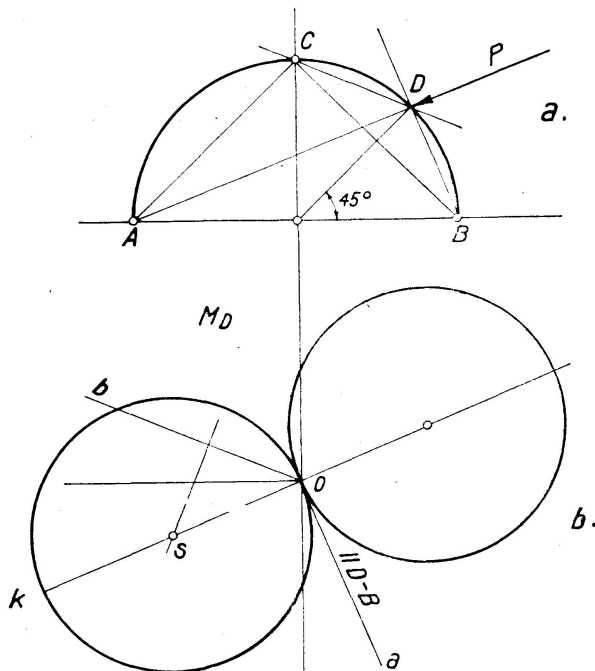

Fig. 11 und 12.

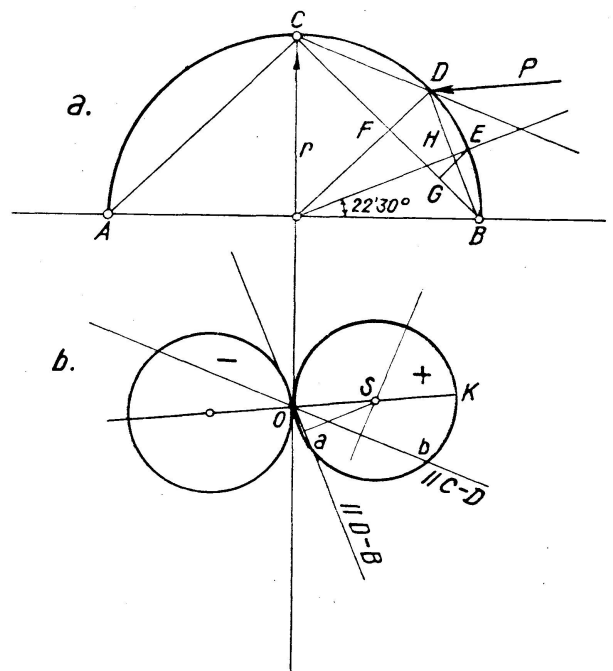

Fig. 13.

If the direction of the force is DB , the direction of the reaction at B is BD and $M_D = 0$. The direction of the zero line is then (Fig. 12 b) $Oa \parallel DB$. The distance between the point E and the chord DB (Fig. 13 a) is $HE = 0,075 r$, hence $M_E = 1 \times 0,075 r = 0,075 r$. The section $Oa = 0,075 r$ is drawn from the point O (Fig. 13 b) parallel to DB , on an arbitrarily chosen scale of forces.

If the force P has the direction CD , the direction of the reaction at B is BC and the direction of the reaction at A is AC . It appears from the triangle of forces Cbc (Fig. 14), in which $Cb = 1$, that $Cc = B = 0,925 r$. The arm of the moment $FD = 0,29 r$, $EG = 0,216 r$, hence the moment in D ,

$$M_D = 0,925 \cdot 0,29 r = 0,268 r$$

$$M_E = 0,925 \cdot 0,216 r = 0,200 r.$$

In Fig. 12 b, $Ob \parallel CD$, $Ob = 0,268 r$. The axis of symmetry of the section Ob cuts in S the vertical to Oa drawn from O , being the centre of a circle of the radius OS .

Exceptional cases.

All cases in which the law of superposition cannot be applied are exceptions from the formulae given above. We shall consider some of them.

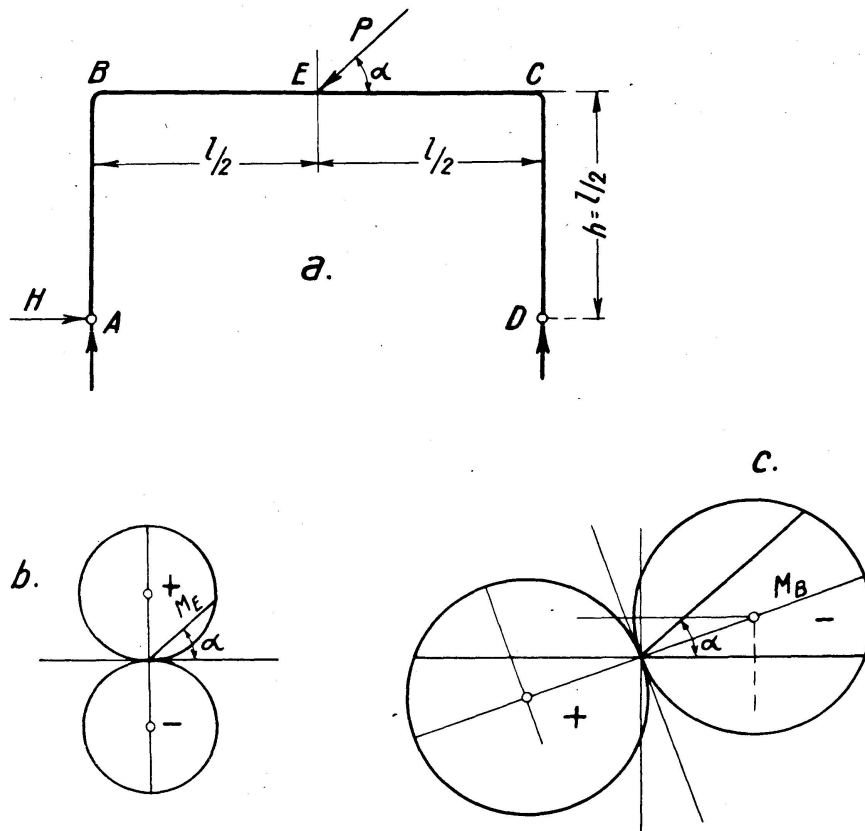

Fig. 15.

1. Continuous beam not anchored, on supports. The forces at the supports of such a beam must be positive. When the weight of the beam may be neglected, i. e. when the reaction caused by the dead load is very small in comparison with the reaction caused by the force P , the circle corresponding to the negative reactions falls out of the graphic 5 (Fig. 16).

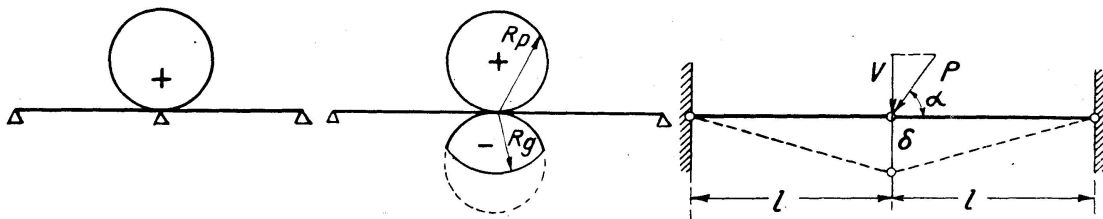

Fig. 16.

Fig. 17.

Fig. 18.

If the reaction R_g caused by the constant dead load of the continuous beam is greater than the greatest possible negative reaction $R_{p\ max}$ caused by the concentrated force P , the influence of the direction of this force is identical with the influence in a continuous beam anchored to both supports. Finally, if the reaction $R_g < R_{p\ max}$, only one part remains of the circle corresponding to negative reactions, viz. the part in which the distance from O is smaller than R_g (Fig. 17). The arc drawn from the centre O with a radius R_g cuts the remaining part from the negative circle.

2. A system of two rods lying in one straight line (Fig. 18) hinged together and also fixed to the supports by means of hinges. This is the limiting case of a three-hinged arch, with camber equal to O .

The force P acts on the middle hinge in a certain direction. Its vertical component is

$$V = P \sin \alpha \tag{19}$$

The vertical displacement of the middle hinge

$$\delta = l \sqrt[3]{\frac{V}{EF}} \tag{20}$$

where $F =$ is the cross-sectional area of the rod and $E =$ the modulus of elasticity of the material of the rod.

Introducing (19) into (20)

$$\delta = l \sqrt[3]{\frac{P}{EF}} \cdot (\sin \alpha)^{\frac{1}{3}} \tag{21}$$

The equation (21) has the general form

$$r = c \sin^n \alpha \tag{22}$$

besides which,

$$c = l \sqrt[3]{\frac{P}{EF}}, \tag{22a}$$

$$n = \frac{1}{3}.$$

This represents a certain curve expressed in polar coordinates r and α . The rectangular coordinates are

$$y = r \sin \alpha$$

$$x = r \cos \alpha$$

Introducing (22),

$$y = c \sin^{n+1} \alpha \tag{23}$$

$$x = c \sin^n \alpha \cos \alpha \tag{24}$$

hence

$$x^2 + y^2 = r^2 = c^2 \sin^{2n} \alpha \tag{25}$$

According to (23)

$$y^2 = c^2 \sin^{2n+2} \alpha \tag{26}$$

Dividing (26) by (25),

$$\frac{y^2}{x^2 + y^2} = \sin^2 \alpha$$

Raising this formula to the $(n + 1)^{th}$ power, and considering the formula (26):

$$\left(\frac{y^2}{x^2 + y^2}\right)^{n+1} = \frac{y^2}{c^2},$$

it follows that

$$(x^2 + y^2)^{n+1} = c^2 y^{2n} \tag{27}$$

In our case $n = \frac{1}{3}$, and

$$(x^2 + y^2)^{\frac{4}{3}} = c^2 y^{\frac{2}{3}}$$

or

$$(x^2 + y^2)^4 = c^6 y^2$$

Introducing the dimensionless coordinates

$$\xi = \frac{x}{c}, \quad \eta = \frac{y}{c}, \quad (28)$$

it follows that

$$\eta = (\xi^2 + \eta_1^2)^2 \quad (29)$$

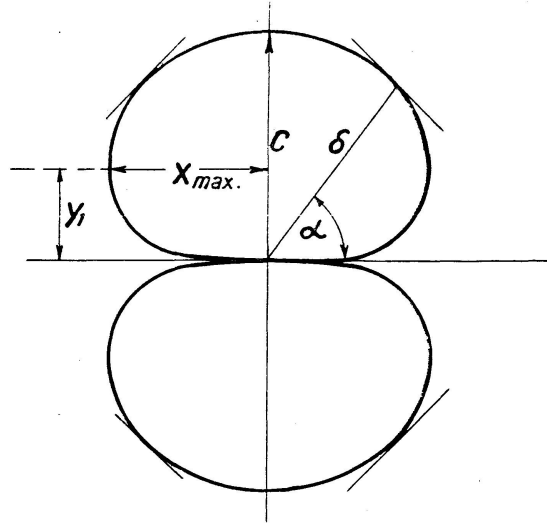

Fig. 19.

In order to realize the form of the corresponding curve, ξ_{max} and a corresponding $\eta = \eta_1$ are to be determined. Differentiating (29) we obtain:

$$d\eta = 2(\xi^2 + \eta_1^2)(2\xi d\xi + 2\eta_1 d\eta_1)$$

Dividing by $4d\eta$ we get

$$\frac{1}{4} = (\xi^2 + \eta_1^2) \left(\xi \frac{d\xi}{d\eta_1} + \eta_1 \right)$$

Introducing $\frac{d\xi}{d\eta_1} = 0$, we have:

$$\frac{1}{4} = (\xi_{max}^2 + \eta_1^2) \eta_1 \quad (30)$$

As per equation (29)

$$\xi^2 + \eta_1^2 = \sqrt{\eta} \quad (31)$$

therefore

$$\frac{1}{4} = \eta_1 \sqrt{\eta_1}$$

$$\eta_1^3 = \frac{1}{16} \eta_1 = 0,398, \quad \eta_1 = 0,398 c.$$

As per equation (31)

$$\xi_{max}^2 = \sqrt{0,398} - 0,398^2 = 0,63 - 0,158 = 0,472.$$

Therefore

$$x_{max} = c \sqrt{0,472} = \pm 0,688 c.$$

Fig. 19 shows the relation between δ and α , for c compare equation (22a).

Equation (27) will be also valid in the case of pressure of the cylinder of a movable bearing on a flat supporting plate. According to the HERTZ formula, the greatest compression stress between a cylinder of diameter r

and length s , and its supporting plate, will be, with reaction B :

$$p_{max} = 0,418 \sqrt{\frac{BE}{rs}}$$

but

$$B = V \frac{a}{l} = P \frac{a}{l} \sin \alpha$$

therefore

$$p_{max} = c \sqrt{\sin \alpha}, \text{ hence } n = \frac{1}{2},$$

if

$$c = 0,418 \sqrt{\frac{PE}{rs} \cdot \frac{a}{l}}$$

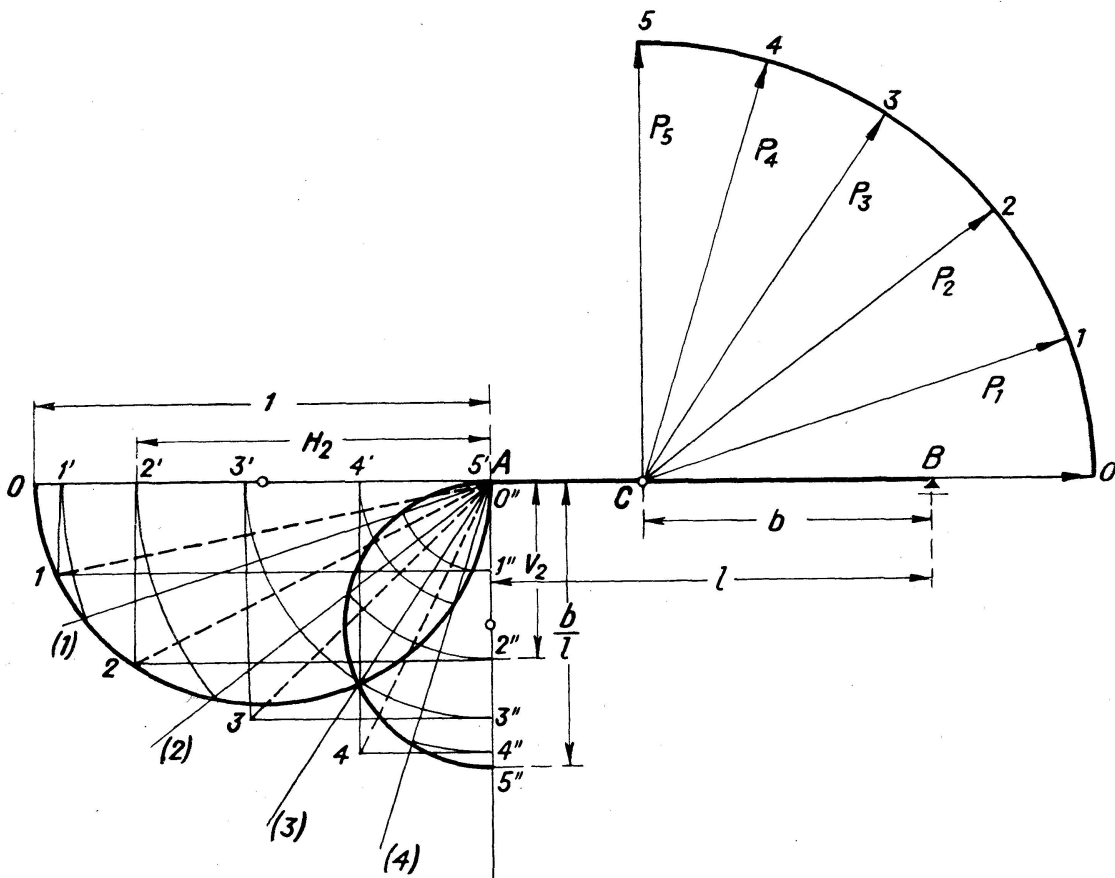

Fig. 20.

The horizontal displacement of an antennae-tower, fixed from above with stretched ropes is another example of a system where the law of superposition cannot be applied. Here the displacement is not proportional to the horizontal component H , and is therefore not linearly proportional to $P \cos \alpha$, but depends on it in a more complicated way. (Compare CHMIELOWICZ: Die Abhängigkeit der Horizontalkraft des gespannten Seiles von der Verschiebung seiner Aufhängepunkte. Bautechnik 1931, page 737.)

We have up to now considered mechanical functions being the consequences of force P and having a constant direction, as, for instance, the vertical or horizontal components of the displacement or of the reaction. The reaction R , or the displacement, can be determined as a resultant of the

horizontal component H and the vertical component V . These components may be obtained graphically (Fig. 20). The vertical component reaches its maximum

$$V_{max} = \frac{b}{l}, \text{ when the force } P = 1 \text{ acts vertically } (\alpha = 90^\circ).$$

In this case the horizontal component is equal to zero. It reaches the maximum $H_{max} = 1$, for $\alpha = 0$. The following construction results therefore: A circle of diameter 1 is drawn tangential at A to the vertical line, and a circle of diameter $\frac{b}{l}$ tangential at A to AB . The straight line $A[2]$, parallel to P_2 , cuts both circles. The chord of the smaller circle represents the vertical component of reaction V_2 ; the chord of the larger one the horizontal component H_2 . The diagonal $A2$ of the rectangle of base H_2 and height V_2 represents the reaction R_2, P .

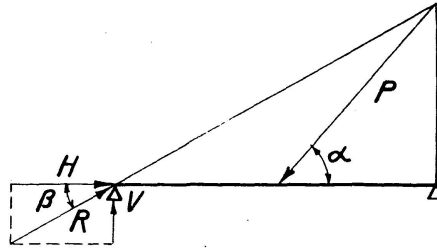

Fig. 21.

The vertical reaction of the left support of a girder on two supports (Fig. 20).

$$V = P \sin \alpha \frac{b}{l} = Pk \sin \alpha \quad (a)$$

The vertical reaction

$$H = P \cos \alpha \quad (b)$$

therefrom

$$R^2 = V^2 + H^2 = P^2(k^2 \sin^2 \alpha + \cos^2 \alpha) \quad (c)$$

The relation between R and α can be determined in rectangular coordinates X and Y , besides

$$X = R \cos \alpha, \quad Y = R \sin \alpha \quad (d)$$

Eliminating α from equations (c) and (d), we obtain:

$$R^4 = P^2(k^2 Y^2 + X^2)$$

According to equation (b)

$$R^2 = X^2 + Y^2$$

therefore

$$(X^2 + Y^2)^2 = P^2(k^2 Y^2 + X^2) \quad (e)$$

This is a curve of the 4th degree. Equation (e) remains unchanged when introducing $-X$ instead of X and $-Y$ instead of Y , the curve has therefore a centre. Differentiating the formula (c) with respect to α we obtain:

$$\frac{dR^2}{d\alpha} = P^2(2k^2 \sin \alpha \cos \alpha - 2 \sin \alpha \cos \alpha) = P^2 \sin 2\alpha (k^2 - 1)$$

$R = \max(\min)$ for $\sin 2\alpha = 0$, therefore $\alpha = 0$ and $\alpha = \frac{\pi}{2}$.

The curve is symmetrical with respect to the horizontal and vertical axes. It is similar to an ellipse.

The directions of the reaction R and of the force P are generally different; compare Fig. 21.

Equation $\alpha = \beta$ holds good only when $\alpha = 0$ and $\alpha = \pm \frac{\pi}{2}$.

According to (a) and (b)

$$\tan \beta = \frac{V}{H} = K \tan \alpha.$$

If the force P is acting in the middle of the girder, then

$$\tan \alpha = 2 \tan \beta = z.$$

The deviation between the direction of the force and the direction of the reaction is

$$\gamma = \alpha - \beta = \arctan z - \arctan \frac{z}{2}$$

and reaches its maximum, when

$$\frac{d\gamma}{dz} = \frac{1}{1+z^2} - \frac{1}{2} \cdot \frac{1}{1+\left(\frac{z}{2}\right)^2} = 0.$$

Hence

$$\begin{aligned} z &= \sqrt{2} = \tan \alpha & \beta &= 35^\circ 15'. \\ \tan \beta &= \frac{\sqrt{2}}{2} = \cot \alpha & \alpha &= 54^\circ 45'. \end{aligned}$$

The greatest deviation is $\gamma_{max} = 19^\circ 30'$.

Summary

see "Conclusions", page 38.

Zusammenfassung.

1. In jedem System zeichnen sich für eine beliebige mechanische Größe M für jeden Angriffspunkt der Kraft zwei zueinander rechtwinklig-stehende Richtungen aus, die dadurch charakterisiert sind, daß $M = 0$ bzw. $M = \max$ wird, wenn die Kraft in der einen, bzw. in der andern dieser Richtungen wirkt.

2. Ist eine bestimmte Größe für einen bestimmten Winkel α gleich Null, dann ist sie auch Null für einen Winkel $\alpha = \pm 180^\circ$. Für $\alpha = \pm 90^\circ$ dagegen erreicht die Größe ihr Maximum.

3. Für einen beliebigen Punkt des Systems und für eine beliebige mechanische Größe dieses Systems gibt es immer eine Krafrichtung, für die die Größe gleich Null ist. Das gleiche gilt für die entgegengesetzte Richtung. Für winkelrechte Richtungen erreicht die Größe ihr pos. resp. neg. Maximum. Es ist unmöglich, daß für zwei zueinander nicht winkelrechte Richtungen die Größen die Werte $M = 0$, bzw. $M = \max$ annehmen könnten.

4. Wirkt auf einen bestimmten Punkt eines Trägers oder eines beliebigen Systems eine Kraft von konstantem Werte und veränderlicher Richtung, so verursacht sie in allen mechanischen Größen dieses Systems, die eine konstante Richtung haben, Änderungen von Null bis $+\max$ und von $+\max$ bis Null bei jeder vollen Umdrehung der Krafrichtung.

Résumé.

1. Dans chaque système, pour une grandeur d'ordre mécanique arbitraire et pour un point quelconque d'application de l'effort, on distingue deux directions perpendiculaires entre elles, et qui sont caractérisées par ce fait qu'elles correspondent respectivement à $M = 0$ et $M = \max$, suivant que l'effort s'exerce suivant l'une ou l'autre de ces directions.

2. Si une grandeur déterminée se trouve être nulle pour un angle déterminé α , elle sera également nulle pour tout angle $\alpha \pm 180^\circ$. Pour $\alpha \pm 90^\circ$, par contre, la grandeur considérée atteint son maximum.

3. Pour un point arbitraire du système et pour une grandeur d'ordre mécanique de ce système, il existe toujours une direction d'effort pour laquelle cette grandeur est égale à zéro. Il en est d'ailleurs de même pour la direction opposée. La grandeur atteint son maximum, positif ou négatif, pour les directions perpendiculaires. Il n'est pas possible que les grandeurs considérées passent à la fois par les valeurs $M = 0$ et $M = \max$, pour deux directions qui ne seraient pas perpendiculaires, entre elles.

4. Si un effort de valeur constante et de direction variable agit en un point déterminé d'une poutre ou d'un système quelconque, cette effort a pour conséquence, pour toutes les grandeurs mécaniques du système, qui sont caractérisées par une direction déterminée, des variations entre 0 et $+\max$ et entre $+\max$ et 0 à chaque révolution complète de l'effort.