

The welded design for the new Victoria Bridge, Bath

Autor(en): **Grisenthwaite, T.C.**

Objektyp: **Article**

Zeitschrift: **IABSE publications = Mémoires AIPC = IVBH Abhandlungen**

Band (Jahr): **5 (1937-1938)**

PDF erstellt am: **16.08.2024**

Persistenter Link: <https://doi.org/10.5169/seals-6156>

Nutzungsbedingungen

Die ETH-Bibliothek ist Anbieterin der digitalisierten Zeitschriften. Sie besitzt keine Urheberrechte an den Inhalten der Zeitschriften. Die Rechte liegen in der Regel bei den Herausgebern.

Die auf der Plattform e-periodica veröffentlichten Dokumente stehen für nicht-kommerzielle Zwecke in Lehre und Forschung sowie für die private Nutzung frei zur Verfügung. Einzelne Dateien oder Ausdrucke aus diesem Angebot können zusammen mit diesen Nutzungsbedingungen und den korrekten Herkunftsbezeichnungen weitergegeben werden.

Das Veröffentlichen von Bildern in Print- und Online-Publikationen ist nur mit vorheriger Genehmigung der Rechteinhaber erlaubt. Die systematische Speicherung von Teilen des elektronischen Angebots auf anderen Servern bedarf ebenfalls des schriftlichen Einverständnisses der Rechteinhaber.

Haftungsausschluss

Alle Angaben erfolgen ohne Gewähr für Vollständigkeit oder Richtigkeit. Es wird keine Haftung übernommen für Schäden durch die Verwendung von Informationen aus diesem Online-Angebot oder durch das Fehlen von Informationen. Dies gilt auch für Inhalte Dritter, die über dieses Angebot zugänglich sind.

THE WELDED DESIGN FOR THE NEW VICTORIA BRIDGE, BATH.

DIE GESCHWEISSTE KONSTRUKTION DER NEUEN
VICTORIA-BRÜCKE IN BATH.

L'EMPLOI DE LA SOUDURE À LA CONSTRUCTION
DU NOUVEAU PONT VICTORIA À BATH.

T. C. GRIENTHWAITE, B. Sc., M. Inst. C. E., M. I. Struct. E., London.

Introductory.

This paper deals with the design of a welded structure which is to replace one of the old bridges over the River Avon in the City of Bath. Bath, so named because it was the most famous of the Roman Baths, still retains all the beauty which made it famous throughout the ages.

There are many bridges over the River, some of which are of considerable antiquity, but unfortunately, most of them are now inadequate for the ever-increasing needs of modern traffic, and in 1935 the Bath City Council promoted a comprehensive plan for reconstructing or strengthening five bridges. Two of these, the Victoria Bridge and the Windsor Bridge, representative of early design in wrought iron, would provide very useful cross river links between the Upper and Lower Bristol roads, but they are at present only suitable for pedestrians. It was, therefore, decided to replace both by new structures capable of carrying the heaviest type of vehicular traffic.

Existing Victoria Suspension Bridge.

Before discussing the new design, a few notes on the original structure may be of interest.

It was built as a toll bridge in 1837 by a private company, known as the Victoria Bridge Co. (Bath) Ltd., and is of the suspension type, having a clear span between piers of 139' 10" with a width of 18-ft. The Engineer was Mr. DREDGE, a resident of Bath, who patented his system of construction, and according to an article in "The Civil Engineer and Architects Journal" of 1840, the cost of the structure was £ 1,650.

As the Bridge Company only allowed vehicles not exceeding 35-cwts. each to pass over the bridge at a walking pace, and only one at a time, it was not surprising that when the Corporation took it over it was immediately closed to vehicular traffic.

Factors determining the selection of the type of the new Bridge.

Although only of comparatively small dimensions, the design of the new bridge presented a number of interesting problems. In the first place, the River Avon Catchment Board required a clear width of 110-ft. between banks, together with a tow path of 15-ft. on one side for the future develop-

ment of the river. In addition, a clear area of 1,680 square feet above normal water level was desirable so as to provide ample waterway during periods of flood.

These conditions dictated a single span of over 150-ft. since the new bridge will cross the river at an angle of $18\frac{1}{2}^{\circ}$. Both sides of the river adjacent to the bridge are built up with factories and other buildings. These, together with the existence of a level crossing about 100-ft. away on the south side, prohibited all but the slightest variations in the present road levels. The maximum permissible road level at the centre of the span is 70.00 O. D. as compared with the highest recorded flood level of 64.00 O. D. From these restricted levels it was evident that a deck bridge of the usual construction was impracticable. The normal solution to the problem would be a through girder bridge of either the truss or tied arch type, but neither of these were considered of pleasing appearance.

After closely considering and preparing several alternative designs in steel and reinforced concrete the City Engineer, Mr. F. P. Sissons, M. I. M. and Cy. E. finally recommended a steel bridge of a rigid frame type, which was adopted by the Council in May 1935. This type of construction was made possible by the fact that bores which had been taken proved that suitable foundations could be obtained on Lias rock at a reasonable level.

The decision to adopt a bridge of this span marked a considerable advance in the use of the rigid frame type in Great Britain. At present, the only steel structures of this type are the Billingham Branch of the Tees Bridge¹⁾ over the L. N. E. Rly., and the Wolvercote Bridge on the Oxford Northern By-Pass²⁾. The former is a five span bridge of all welded construction, having 2 spans of 28' 0", 2 of 48' 0", and 1 of 64' 0". The latter is a single span of 82' 10" of riveted construction entirely encased in concrete.

General Description for the new Rigid Frame Bridge.

As previously mentioned, and as shown in Figure 1, the clear span of the new Victoria Bridge will be about 150-ft. and actually the centres of bearings were fixed at 156' 9". The width of the carriageway was settled at 18-ft. (sufficient for two lines of vehicles) and two footpaths, each 5' 0" wide, were considered essential.

The profile of the frames was determined by the flood level, the provision of adequate waterway and the necessity for a clearance of 8-ft. over the tow path. It was found necessary to space the frames at 21' 0" centres thus bringing them under the footways, so as to obtain the maximum depth of girder.

By this arrangement, and allowing a clearance of 9" above the highest recorded flood level, the greatest depth of frame obtainable at the centre of the span was 5' 2" over the flange plates.

In order to fit in with the required road levels and gradients, the bearing levels were fixed at 42.92 O. D. on one bank, and 44.84 O. D. on the other. The effective rise from the centre line of the bearings to the centre of the frames is $23' 10\frac{3}{4}"$, giving a rise-span ratio of 1:6.55.

¹⁾ Billingham Branch Bridge. Paper by W. P. HALDANE, B. Sc. M. Inst. C. E., published in the proceedings of the Institution of Civil Engineers 1934—35, volume 240, part 2.

²⁾ Oxford Northern By-Pass. Engineer, Mr. G. T. BENNET, B. Sc. Assoc. M. Inst. C. E. County Surveyor of Oxford.

It may be pointed out that the depth-span ratio of the frames is only 1/30.4 showing clearly the advantages of this form of construction where the available depth is very restricted.

The profile adopted fulfils all the required conditions except that the effective waterway above normal water level is reduced from 1,680 to 1,610 square feet.

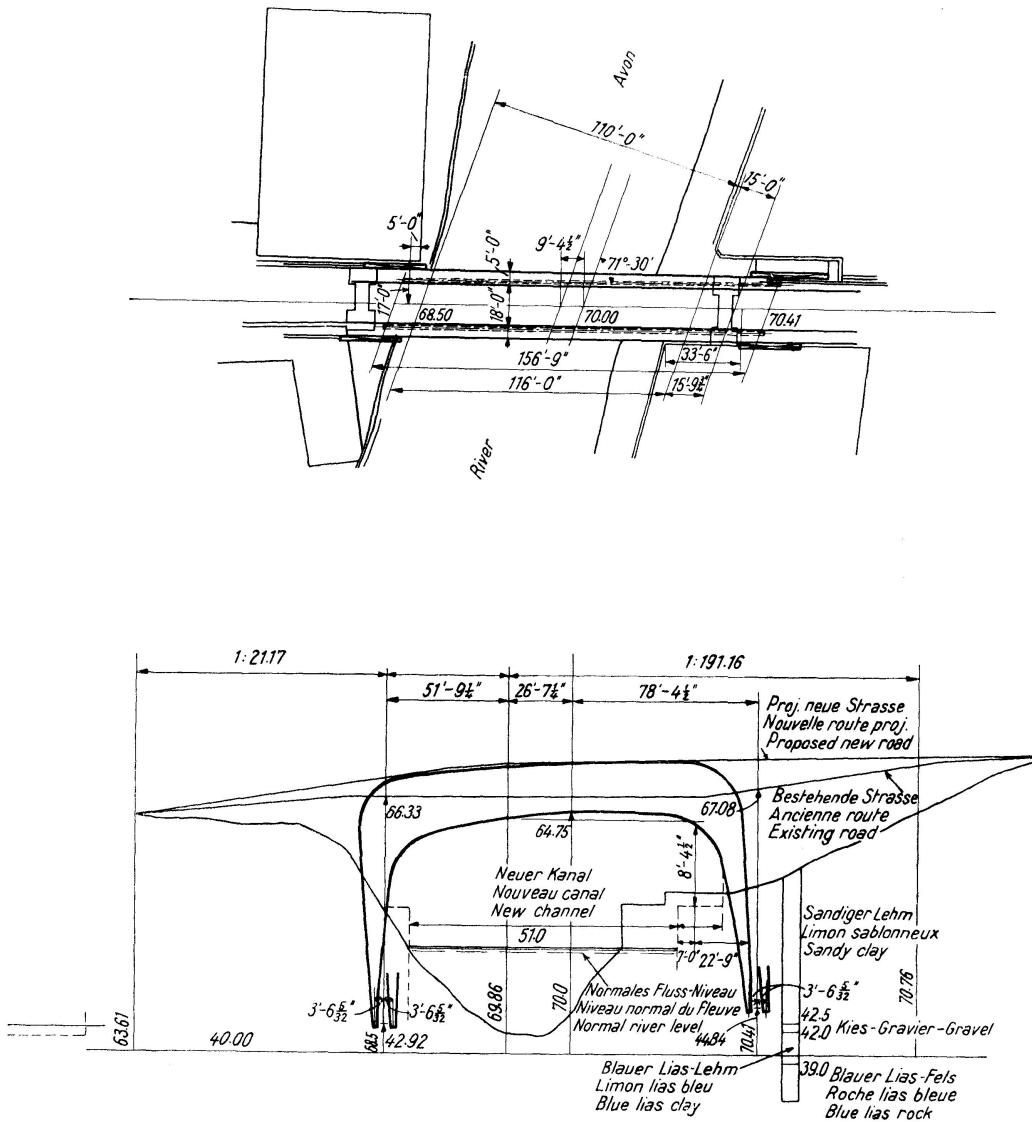

Fig. 1.

The cross girders are spaced generally at 10' 6" centres and carry a 7½" reinforced concrete deck, the road surface being formed of 2" of asphalt. Footway cantilever brackets of welded construction are connected on the outside of each frame opposite the cross girders. These brackets are specially shaped to provide the largest possible pipe duct under the footway slab. The ducts are of concrete carried on steel trough plates, which are supported on the cantilever footway brackets. The footway itself consists of 2½" thick precast concrete slabs forming a removable cover to the pipe trench. The hand-railing of simple construction, is of wrought iron with a cast iron top

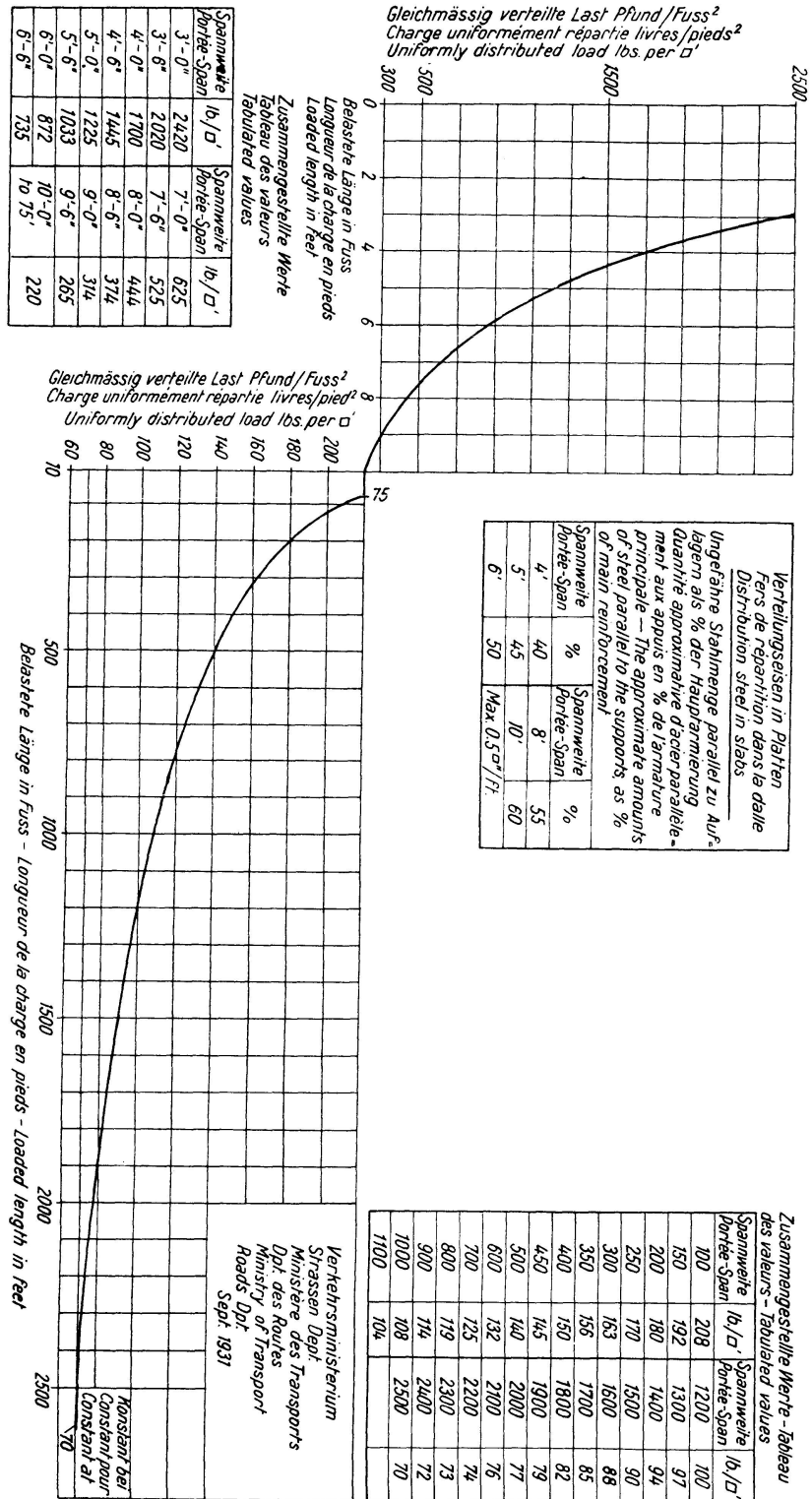

Fig. 2.

Standard load for highway bridges. — Equivalent loading curve.

Fig. 2.

The uniformly distributed load applicable to the "loaded length" of the bridge or member in question is selected from the curve or table.

The "loaded length" is the length of member loaded in order to produce the most severe stresses. In a freely supported span the "loaded length" would thus be (a) for bending moment; the full span. (b) for shear at the support; the full span. (c) for shear at intermediate points; from this point to farther support.

In arches and continuous spans the "loaded length" can be taken from the influence line curves.

The live load to be used consists of two items: (1) The uniformly distributed load which varies with the loaded length, and which represents the ordinary axle loads of the M.T. standard train, perfectly distributed. (2) An invariable knife edge load of 2,700 lbs. per foot of width applied at the section where it will, when combined with the uniformly distributed load, be most effective, *i. e.* in a freely supported span: (a) for bending moment at midspan; at midspan point. (b) for shear at the support; at the support. (c) for shear at any section; at the section.

This knife edge load represents the excess in the M.T. standard train of the heavy axle over the other axles, this excess being undistributed (except laterally as already assumed).

In spans of less than 10 ft. (*i. e.* less than the axle spacing) the concentration serves to counteract the overdispersion of the distributed load.

On slabs the knife edge load of 2,700 lbs. per ft. of width is taken as acting parallel to the supporting members, irrespective of the direction in which the slab spans.

In longitudinal girders, stringers, etc., this concentrated loading is taken as acting transversely to them (*i. e.* parallel with their supports).

In transverse beams the concentrated loading is taken as acting in line with them (*i. e.* 2,700 lbs. per ft. run of beam).

If longitudinal or transverse members are spaced more closely than at 5 ft. centres, the live load allocated to them shall be that calculated on a 5 ft. wide strip. With wider spacing this strip will be equal to the girder spacing.

In all cases, irrespective of span length, one knife edge load of 2,700 lbs. per foot of width is taken as acting in conjunction with the uniform distributed load appropriate to the span or "loaded length".

rail, bolted to longitudinal steel fascia channels attached to the top of the footway brackets.

The above is a brief description of the general design of the new bridge, and it should be mentioned here that two designs were prepared, one for a welded and the other for a riveted bridge.

Live Loads.

The live load adopted is the standard Ministry of Transport loading introduced in 1923, consisting of a traction engine weighing 20-tons, followed by three 13-ton trailers. This line of vehicles is assumed to occupy a 10-ft. width of carriageway, and an impact of 50 % is allowed.

In order to simplify design, this load was modified in 1931 to an equivalent uniformly distributed load, together with a knife edge load of 2,700-lbs. per lin. ft. The uniformly distributed load has a maximum value of 2,420-lbs. per sq. ft. for 3' 0" span, which is reduced to 220-lbs. per sq. ft. at 10-ft. For loaded lengths of 10—75-ft. the distributed load is constant at 220-lbs. per sq. ft. and is reduced thereafter down to a minimum of 70-lbs. per sq. ft. for a span of 2,500-ft. The uniformly distributed loads and knife edge load are combined so that together they produce maximum moments or shears. See Figure 2.

Method of Calculation.

The design of a rigid frame is similar to that of an arch, and whilst there is no difficulty in calculation, the work involved is both long and tedious, but can be simplified and readily checked by careful tabulation. No direct method of calculation can be employed for ascertaining the sections, and it is necessary to assume preliminary sections, either by trial, or from previous experience. From these sections, the moments of inertia are calculated at various points along the span. The next step is to calculate the influence ordinates for horizontal thrust, which in this case were obtained by the method of elastic weights.

Influence lines for various points in the span were then drawn for moment, shear and axial thrust, for which the sections were required. If the sections had differed materially from the assumed preliminary sections, it

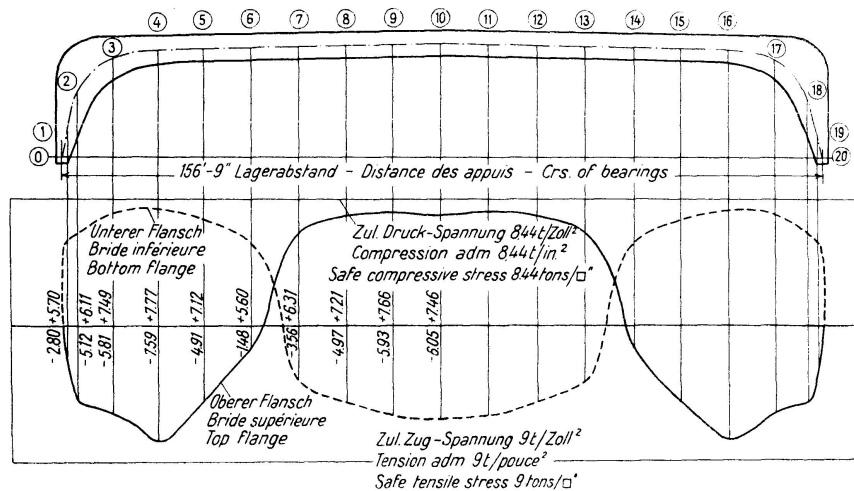

Fig. 3.

Endgültige Spannungskurven der Gurtungen für geschweißte Konstruktion.
Lignes définitives des tensions pour les membrures d'une construction soudée.
Curves Shewing Final Flange Stresses for Welded Design.

would have been necessary to recalculate the horizontal thrust on the revised moments of inertia.

Stresses.

The stresses adopted were those laid down in the British Standard Specification No. 153, Part 3, for Girder Bridges, the basis stress being 9-tons per square inch in tension. The Metallic Arc Welding was in accordance with B. S. S. No. 538, 1934.

The maximum flange stresses are shown in Fig. 3.

Details of Welded Design.

Only a brief description of the essential features of the detail design is possible within the limits of this paper.

The main frames, which are of solid web construction with continuous fillet welds connecting the flange plates to the web, are shown in detail in Figure 4. The horizontal portion of the frame has a web $\frac{1}{2}$ " thick which is increased to $\frac{3}{4}$ " at the haunches, and to $1\frac{1}{4}$ " in the vertical legs. Figure 5

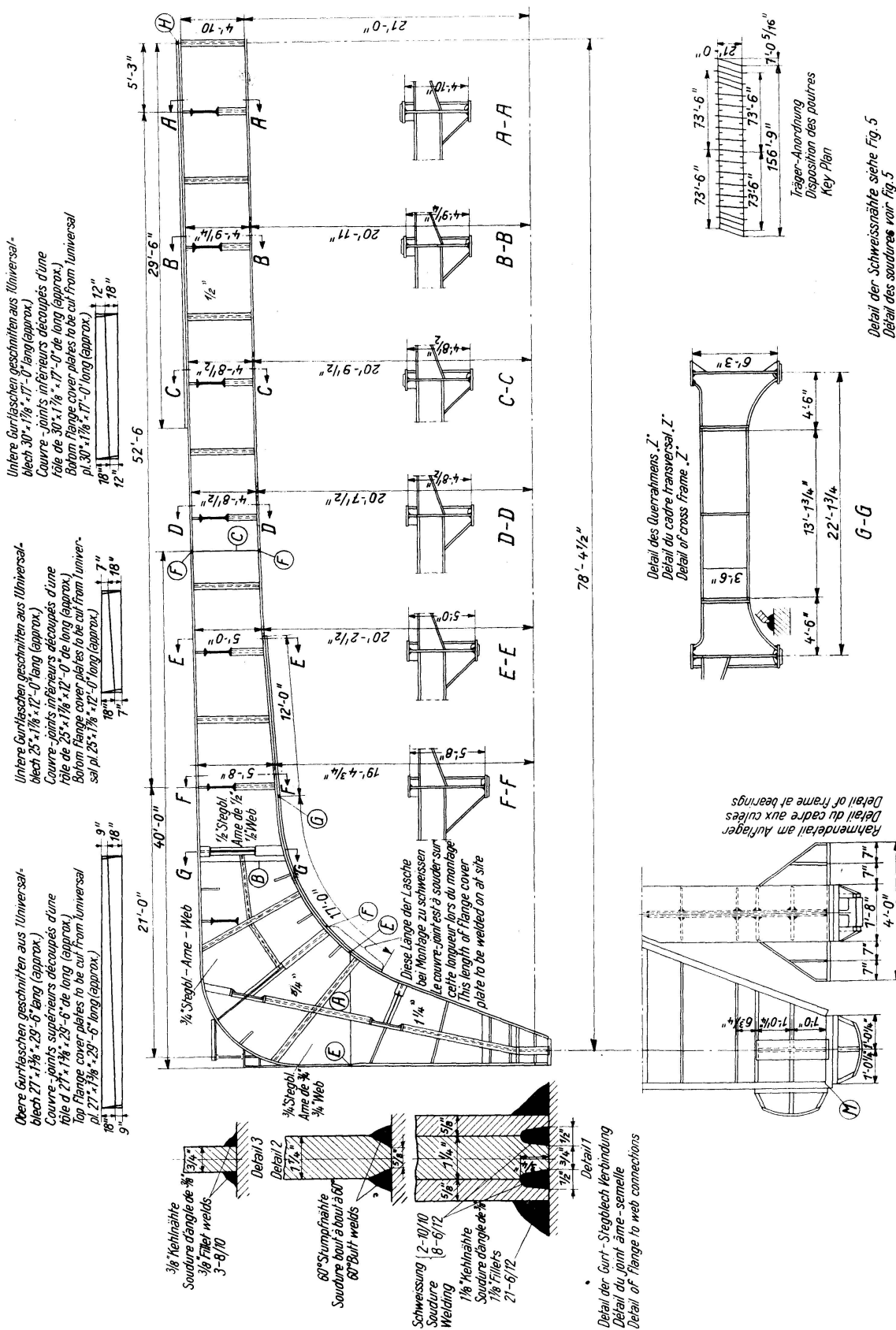

Fig. 4.

shows the details of the double V — 70° butt welds used for connecting the web plates of different thicknesses, and the single V — 70° butt weld for the joints in the $\frac{1}{2}$ " web plate.

Referring again to Figure 4, it will be seen that each flange consists of a main plate 20" wide extending the full length of the frame, the thickness being $1\frac{7}{8}$ " over the centre portion, and $2\frac{1}{4}$ " at the vertical legs. This plate is connected to the $\frac{1}{2}$ " and $\frac{3}{4}$ " webs by means of $\frac{3}{8}$ " continuous fillet welds, and by 60° butt welds to the $1\frac{1}{4}$ " web of the vertical legs. The outside plates on each flange are of constant thickness throughout, but vary in width from the minimum dimensions shown to a maximum of 18", the tapered plates being cut in pairs from standard universal plates. The tapering of the outer plates is an effective method of curtailing the flanges, and the use of plates of 18" maximum width simplifies the welding to the 20" main flange plates. Table 1 shows the design of the fillet welds, some of which are shown in Figure 5.

Particular care was taken to ensure adequate stiffening of the flanges round the curved portions of the frames near the haunches, as the stresses here are a maximum. This was obtained by the use of triangular brackets connecting the flanges to the web in addition to the stiffening afforded by the transverse frames.

A typical cross section showing how the roadway and footway decks are supported by the frames is included in Figure 6. For simplicity of construction of the deck, the levels of the top of the cross girders are kept at a constant distance below the crown of the road. This figure also shows details of the handrailing, skew cross frames 'X' and 'Y', and the end portal frames 'V'. The rigidity of the structure as a whole depends to a large extent on the adequate stiffening of the frames at the ends. It was here that welding offered particular advantages, as it was found possible to obtain a simple design and, at the same time, incorporate these with the subsidiary frames 'X' and 'Y'. This simplicity was not possible in riveted construction.

As all these frames involve skew connections, a small scale model proved very useful in determining the most satisfactory form of these stiffening members.

The vertical loads and the horizontal thrusts at the foot of each frame are taken on two separate bearings, and these loads are then distributed on to the foundations by horizontal and vertical grillages. The alternative method of utilising a single inclined bearing at the end of each frame was also investigated, but the double bearing, although more costly, offers several advantages. Its use will simplify the erection of the frames besides enabling either the vertical or horizontal bearings to be adjusted separately, which is particularly useful in pre-stressing the frames, as described later in the paper.

The two bearings are exactly similar, and the curved bearing surface of each has the same radius struck from a common centre. The bearings are of cast steel and the concave bearing is fitted with a phosphor bronze liner attached to the casting by means of set screws. The maximum horizontal thrust at the foot of each frame is 35.25 tons under full dead and live loads, and the corresponding vertical reaction is 33.0 tons.

As the lower part of the frames is below normal water level, special precautions had to be taken for protecting them against corrosion. It was decided to erect concrete inspection chambers round the lower portions of the

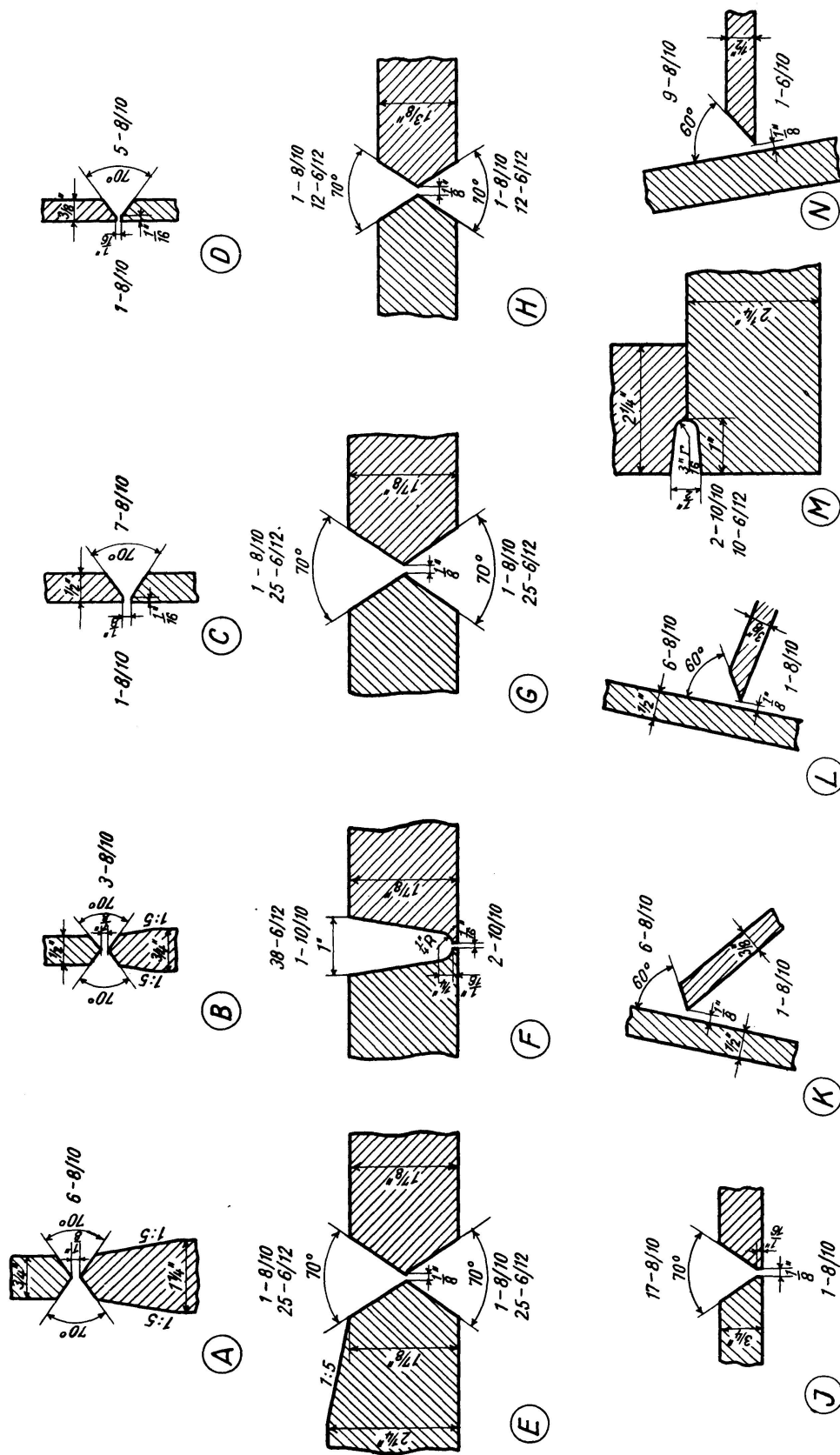

Fig. 5. Details der Schweißnähte zu Fig. 4 und 6 — Détails des soudures des figures 4 et 6 — Welding details for Fig. 4 and 6.

City of Bath.

Reconstruction of Victoria Bridge.
Table of fillet welds.

Stadt Bath.

Neuerstellung der Victoria-Brücke.
Tabelle der Kehlnähte.

Ville de Bath.

Reconstruction du pont Victoria.
Tableau des soudures d'angle.

1	2		3		4		5		6		7		8		9		10		11		12		13		14		15		
	Total load Total-Last Charge totale Tons	Length of end weld Länge der Endnaht Longueur du cordon d'ex- trémité Ins	Total length of side welds Totale Länge der Seitennaht Longueur totale du cordon latéral Ins	Size of weld Schweiß-Stärke (Dicke der Naht) Epaisseur du Cordon End Ende Extrémité Ins	Throat thickness Kehlstärke (Dicke der Kehlnaht) Epaisseur du cordon d'angle End Ende Extrém. Ins	Working stress per lineal inch Arbeitsspannung per Zoll-Länge Taux de travail par pouce linéaire End Ende Extrém. Tons / In	Strength provided Vorgesehene Stärke Epaisseur prévue End Ende Extrém. Tons	Total strength provided Totale vorge- sehene Stärke Epais- seur prévue totale Tons	Make up of welds Aufbau der Schweißnähte Construction du cordon de soudure End Ende Extrém. Côté																				
Flanges to web of main frames Flanschen zu Steg der Hauptrahmen Brides avec âme des cadres principaux	7.4	—	2	—	—	0.796	—	3.98	—	7.96	7.96	—	—	—	—	—	—	—	—	—	—	—	—	—	—	—	—	—	21-6/12
do.	4.25	—	2	—	—	0.5	—	2.5	—	5.0	5.0	—	—	—	—	—	—	—	—	—	—	—	—	—	—	—	—	—	7-8/10
do.	1.36	—	2	—	—	0.265	—	1.3	—	2.6	2.6	—	—	—	—	—	—	—	—	—	—	—	—	—	—	—	—	—	3-8/10
do. Remainder of main frame Übrige Teile des Hauptrahmens Autres parties du cadre principal	1.85	—	2	—	—	0.265	—	1.3	—	2.6	2.6	—	—	—	—	—	—	—	—	—	—	—	—	—	—	—	—	—	3-8/10
Cross girders to main frame Querträger zu Hauptrahmen Entretôises avec cadre principal	26.3	14	36 eff.	Fillet 3/8" Kehlnaht Soudure d'angle	—	0.176	0.265	0.9	22.4	32.4	54.8	3-8/10	1-8/10	—	—	—	—	—	—	—	—	—	—	—	—	—	—	—	3-8/10
Brackets for cross girders to frame Querträgerkonsolen zu Rahmen Consoles des entretôises avec le cadre	26.3	—	44 eff.	—	—	0.176	—	0.9	—	39.6	39.6	—	—	—	—	—	—	—	—	—	—	—	—	—	—	—	—	—	1-8/10
Footway brackets to main frame Gehwegkonsolen zu Hauptrahmen Consoles des trottoirs avec le cadre principal	10 Approx.	10	40 eff.	3/8" do.	—	0.176	0.265	0.9	16	36.0	52.0	3-8/10	1-8/10	—	—	—	—	—	—	—	—	—	—	—	—	—	—	—	3-8/10

Strength of 3/8" gusset plates developed — Strength = 3/8" × 1 × 8 = 3 tons/in. 3/8" side fillet welds provide — 2 × 1.6 = 3 tons/in.
Stärke von 3/8" Knotenblech ausgenützt — Stärke = 3/8" × 1 × 8 = 3 Ton./Zoll. 3/8" Seiten Kehlnähte erlauben 2 × 1.6 = 3 Ton./Zoll.
Epaisseur de 3/8" gousset développé — Epaisseur = 3/8" × 1 × 8 = 3 tons/pouce. Soudure d'angle latérale de 3/8" admise
2 × 1.6 = 3 tons/pouce.

Victoria Bridge, Bath.
Comparison between riveted
and welded design.

Victoria-Brücke in Bath.
Vergleich zwischen genieteter
und geschweißter
Konstruktion.

Pont Victoria à Bath.
Comparaison entre le projet
d'une construction rivée et
d'une construction soudée.

	Riveted design Genietete Konstruktion [Construction rivée	Welded design Geschweißte Konstruktion Construction soudée	Saving in weight Gewichtersparnis Économie de poids	
	Tons	Tons	Tons	Per cent %
Main frames Hauptrahmen Cadres principaux	129.35	91.38	37.97	29.3
End portal frames Endportalrahmen Cadres d'extrémité	10.50	5.40	5.10	51.5
Intermediate bracing frames Zwischenversteifungsrahmen Cadres raidisseurs intermédiaires	10.97	5.43	5.54	49.6
Cross girders and brackets Querträger und Konsolen Entretoises et consoles	16.12	16.15	-0.03	-0.2
Cantilever footway brackets Auskragende Gehwegkonsolen Consoles en porte-à-faux des trottoirs	2.87	2.87	—	—
Trough plates and channel stringers Gebogene Bleche und [-Eisen-AbschlüÙe Tôles bombées et [de liaison	13.24	12.17	1.07	9.2
Grillages for main bearings Rost für Hauptlager Treillis des poutres principales	5.55	5.15	0.40	7.2
Miscellaneous items Verschiedenes Divers	0.67	0.55	0.12	17.9
	189.27	139.10	50.17	26.5
Cast steel bearings GuÙstahl-Lager Appuis d'acier coulé	3.95	3.95	—	—
	193.22	143.05	50.17	26.5

Table 2 — Tabelle 2 — Tableau 2.

frames up to 3' 6" above normal water level. It is not possible to exclude the water from the chambers during periods of flood, but they can be pumped dry for purpose of inspection of the steelwork and bearings. In order to provide adequate maintenance of the steelwork, the following precautions were considered necessary:

1. The legs of the frames are made of copper bearing steel.
2. A minimum of $\frac{1}{4}$ " additional thickness is allowed over the theoretical requirements of all parts of the frame which are subject to immersion.
3. It is intended to coat the legs with special bituminous enamel.

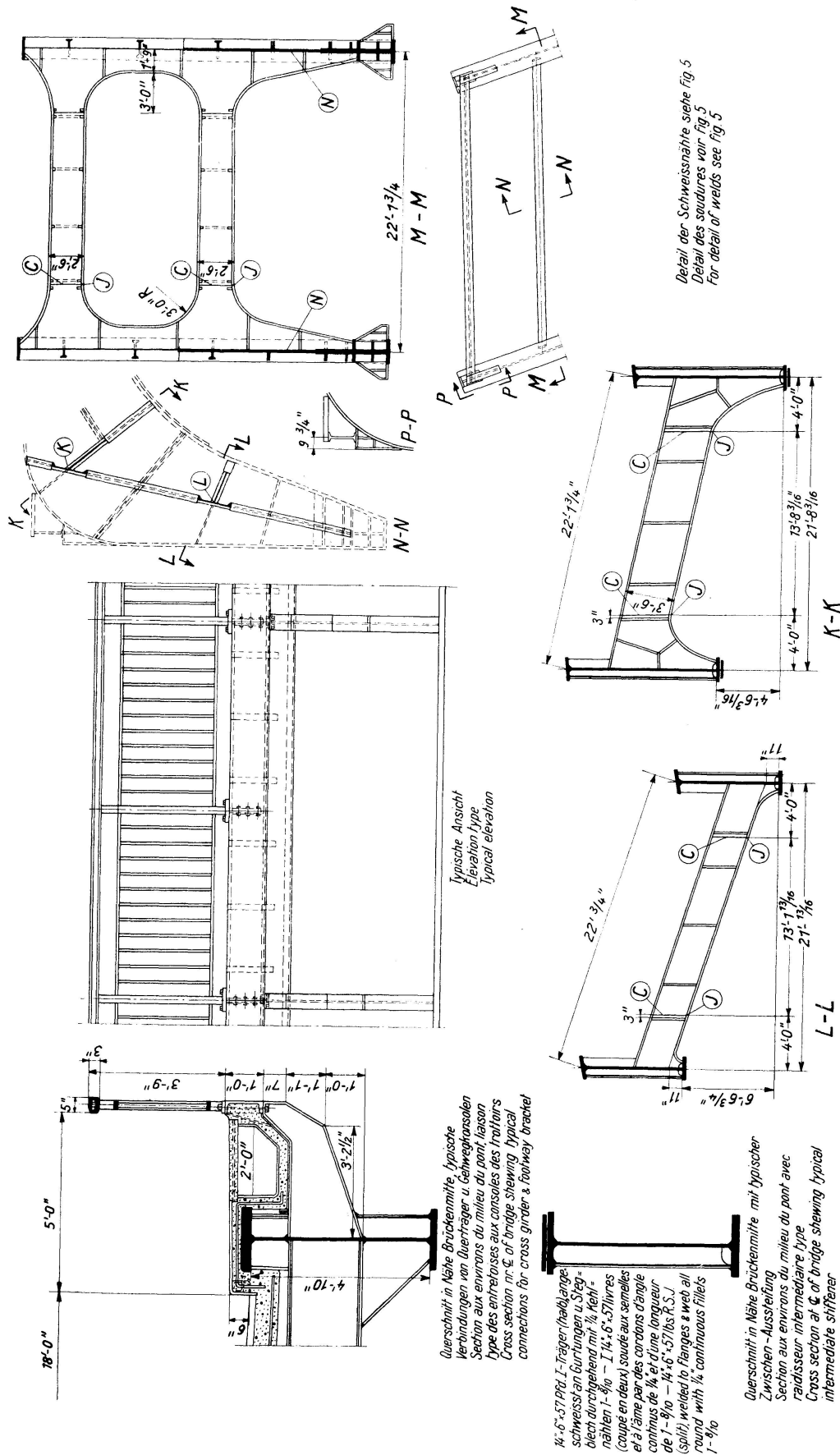

Fig. 6.

As the horizontal thrust from the dead weight of the steelwork alone amounts to 34-tons per frame, precautions must be taken to ensure that this thrust is actually obtained in order that the calculated stress conditions in the frame are realised. After erection of the frames they must be pre-stressed so as to obtain this horizontal thrust.

A suggested method of obtaining this result is to support one end of the frame on the vertical bearing in its final position, and the other end on temporary roller bearings. A hydraulic jack can be inserted above the horizontal bearing and between the back of the frame and the abutments at the roller end, which will provide the necessary thrust. It is then a simple matter to remove the temporary rollers and fix all the bearings in their correct positions by means of suitable steel packings.

The comparative weights of the steelwork in the welded and riveted design may be of interest and is given in Table 2. From this it will be seen that the welded design shows a weight saving of 26 %, which is proof of economy obtained by welding.

The welded structure with its clean surfaces, free of joints and cover plates, undoubtedly gives a pleasant appearance. In addition it is considerably easier to bend the curved flange plates as compared with the angles in the riveted structure.

Summary.

The paper deals with the design of a welded structure to replace one of the old bridges over the River Avon in the City of Bath, and also compares alternative welded and riveted designs.

Owing to very stringent requirements regarding road levels and waterway areas it was necessary to cross the river in a single span of over 150-ft. After consideration of several alternative designs the one selected was a welded portal frame with a span of 156' 9" centres of bearings. There are two main frames spaced at 21-ft. centres, carrying an 18-ft. carriageway and two footpaths, each 5-ft. wide. A reinforced concrete deck is carried on cross girders spaced at 10' 6" centres.

The bridge was designed for the Ministry of Transport Standard loading. The depth of the frame at the centre is 5' 2" over the flange plates, or 1/30.4 of the effective span. The vertical and horizontal thrusts are taken by separate bearings acting from a common centre.

The method of calculation adopted in the design is illustrated in tables. A comparison of the weight of steel between the welded and riveted design shows an economy of 26 % in favour of welding.

Zusammenfassung.

Diese Abhandlung beschreibt die geschweißte Brückenkonstruktion als Ersatz einer der bereits bestehenden Brücken über den Avon in der Stadt Bath. Es wird außerdem der Vergleich zwischen einer genieteten und einer geschweißten Konstruktion gezogen.

Infolge der sehr einschränkenden Bestimmungen bezüglich der Straßenniveletten und der Koten der Wasserstraße war es notwendig, für die Überbrückung eine einzige Spannweite von über 150 Fuß vorzusehen. Aus den verschiedenen untersuchten Varianten ist dasjenige Projekt ausgewählt wor-

den, das einen geschweißten Portalrahmen mit einer Spannweite von 156' 9" zwischen den Kämpfergelenken vorsah. Der Abstand der beiden Hauptrahmen beträgt 21 Fuß, die Breite der Fahrbahn 18 Fuß und die der beiden Gehsteige je 5 Fuß. Die Eisenbeton-Fahrbahndecke wird von Querbalken getragen, die alle 10' 6" angeordnet sind.

Die Brücke wurde entsprechend den Vorschriften des Verkehrsministeriums konstruiert. Die Höhe in Rahmen-Mitte beträgt über 5' 2" oder $1/30,4$ der tatsächlichen Spannweite. Der Vertikal- und der Horizontalschub werden von besonderen Lagern mit gemeinsamer Axe aufgenommen.

Die Berechnungsmethode, die für diese Konstruktion angewendet wurde, ist in den Tabellen näher ausgeführt. Ein Vergleich des Stahlgewichtes zwischen einer geschweißten und einer genieteten Konstruktion ergibt eine Ersparnis von 26 % zu Gunsten der geschweißten Konstruktion.

Résumé.

Ce mémoire traite de la construction soudée d'un pont destiné à remplacer le pont qui franchit l'Avon dans la ville de Bath. Il contient en outre une comparaison entre une construction soudée et une construction rivée.

Par suite des conditions très sévères imposées, relatives à la hauteur de la chaussée et au gabarit de navigation, il fallait prévoir un pont d'une portée unique de 150 pieds. Parmi les différentes solutions étudiées, on a choisi une poutre en cadre soudée d'une portée de 156' 9" entre les articulations des culées. L'écartement des deux poutres maîtresses est de 21', la largeur de la chaussée 18' et les trottoirs ont chacun 5". Le tablier en béton armé est supporté par des entretoises distantes de 10' 6".

Le pont fut construit conformément aux règlements du Ministère des Transports. Le cadre a une hauteur de 5' 2" en son milieu, c.-à-d. $1/30,4$ de la portée réelle. Le cisaillement vertical et horizontal a été transmis aux culées grâce à des articulations d'un type spécial.

La méthode de calcul employée dans cette construction est donnée dans des tableaux. Une comparaison des poids de l'acier dans une construction soudée et dans une construction rivée donne une différence de 26 % en faveur de la construction soudée.

Leere Seite
Blank page
Page vide