

Cairo International Fair (Egypt)

Autor(en): **Hassan, Salah**

Objektyp: **Article**

Zeitschrift: **IABSE structures = Constructions AIPC = IVBH Bauwerke**

Band (Jahr): **5 (1981)**

Heft C-18: **Structures in the Middle East**

PDF erstellt am: **22.07.2024**

Persistenter Link: <https://doi.org/10.5169/seals-16986>

Nutzungsbedingungen

Die ETH-Bibliothek ist Anbieterin der digitalisierten Zeitschriften. Sie besitzt keine Urheberrechte an den Inhalten der Zeitschriften. Die Rechte liegen in der Regel bei den Herausgebern.

Die auf der Plattform e-periodica veröffentlichten Dokumente stehen für nicht-kommerzielle Zwecke in Lehre und Forschung sowie für die private Nutzung frei zur Verfügung. Einzelne Dateien oder Ausdrucke aus diesem Angebot können zusammen mit diesen Nutzungsbedingungen und den korrekten Herkunftsbezeichnungen weitergegeben werden.

Das Veröffentlichen von Bildern in Print- und Online-Publikationen ist nur mit vorheriger Genehmigung der Rechteinhaber erlaubt. Die systematische Speicherung von Teilen des elektronischen Angebots auf anderen Servern bedarf ebenfalls des schriftlichen Einverständnisses der Rechteinhaber.

Haftungsausschluss

Alle Angaben erfolgen ohne Gewähr für Vollständigkeit oder Richtigkeit. Es wird keine Haftung übernommen für Schäden durch die Verwendung von Informationen aus diesem Online-Angebot oder durch das Fehlen von Informationen. Dies gilt auch für Inhalte Dritter, die über dieses Angebot zugänglich sind.



7. Cairo International Fair (Egypt)

Owner: The General Organization for International Exhibitions and Fairs – Nasr City – Cairo

Architect: Bureau d'Art et d'Architecture – Cairo

Engineers: Arab Consulting Engineers:

Dr. A. Moharram & Dr. M. Bakhoum

Contractor: The Misr Concrete Development Co., Cairo

Works duration: 30 months

Service date: March 1980.

Introduction

The Cairo International Fair complex is situated at a new suburb of Cairo, on the main road to the airport.

Among the various buildings the following structures are of particular interest with respect to their structural features:

- three rectangular halls for the trade exhibition
- three square halls and
- the circular arena for the exhibition of horses.

The rectangular halls

They consist of three rectangular halls 75 m, 110 m & 135 m long and 30 m wide. They are covered with a suspended prestressed parabolic shell roof 6 cm thick, stiffened by 22×14 cm ribs spaced 1.0 m center to center.

The ribs have been designed to resist the axial tension force in the roof due to the uniformly distributed loads, plus a bending moment due to an unsymmetrical live load of 50 kg/m² over half the span. Each rib was prestressed with one Freyssinet cable of 12 wires \varnothing 5 mm placed at the centroid of the T-shaped section.

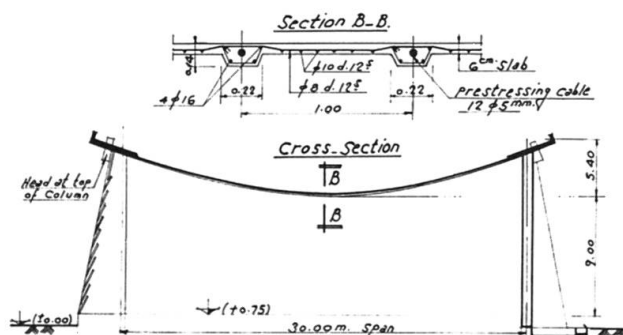

Rectangular halls, cross section

A reinforcement of 2 \varnothing 16 mild steel was added at top and bottom in the ribs to resist the excess of bending tension stresses. The supporting columns, spaced 5 m center to center are of variable cross-section to resist the bending moment due to the horizontal force of about 60 t acting at top of each column. Approximately 1,000 m³ of concrete and 35 t of prestressing wires were used in the roofs for the three halls. The concrete cube strength was 30 N/mm² at 28 days.

Movable shuttering has been used for casting the roof.

The square halls

Each of the three halls 50×50 m consists of four separate square units 25×25 m and 9 m high at the lowest point. For each unit, the roof consists of a hyperbolic paraboloid 8 cm shell, of the inverted umbrella type, supported on one single column at the middle.

The load is carried equally by the two perpendicular sets of parabolic arches forming the shell.

At the edges of the shell, the horizontal edge beams are subject to tension forces while the cross main girders carry compression forces.

Four Freyssinet cables of 12 wires \varnothing 7 mm were used in the edge beams and were reduced to two cables at their ends. Because of the relatively large dimensions of the shell roof, big cross-sections were chosen for the edge beams and cross girders, thus increasing their own weight. In order to reduce the effect of the own weight of the cross main girders, they were connected by prestressed ties. Four cables 12 \varnothing 7 mm were used to prestress the ties in addition to high tensile steel reinforcement.



The square halls

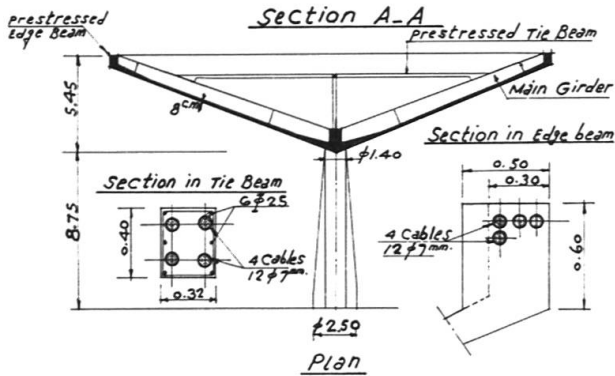

Main entrance

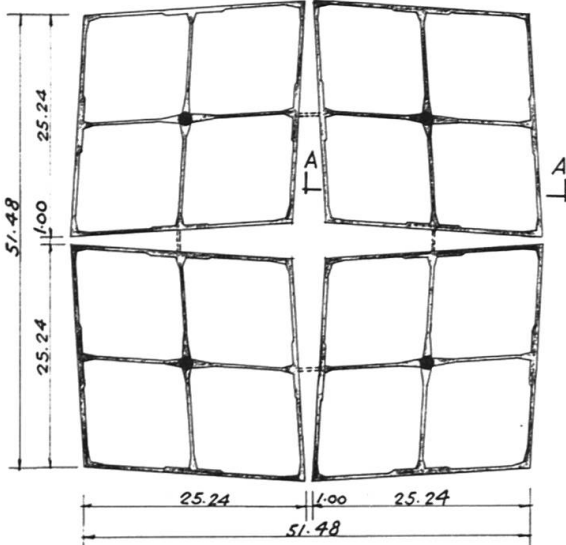

Square halls, plan and section

One of the important advantages to be retained from the geometry of the hyperbolic paraboloid surface is that it permits an easy formwork consisting of two intersecting simple systems of parallel straight lines.

This shell type is also remarkable by its significant material economy and its interesting architectural appearance.

The arena

The arena consists of a hall of circular shape with a diameter of 45 m at the midheight and a total height of 16 m. It contains 10 rows of seats for about 2,000 spectators. The hall is covered with a curved roof which is supported on 24 curved girders arranged radially.

These girders are resting at their base on columns founded on circular footings, and are supported horizontally at their top on a circular compression ring 30×65 cm. The maximum cross-section of the curved girders at midheight is 40×140 cm reinforced by 22 \varnothing 25 mild steel on the tension side.

The width of the girders was gradually increased near the columns due to the high shear stresses.

This structure shows how the application of a simple structural idea can successfully achieve a remarkable work.

(Salah Hassan)

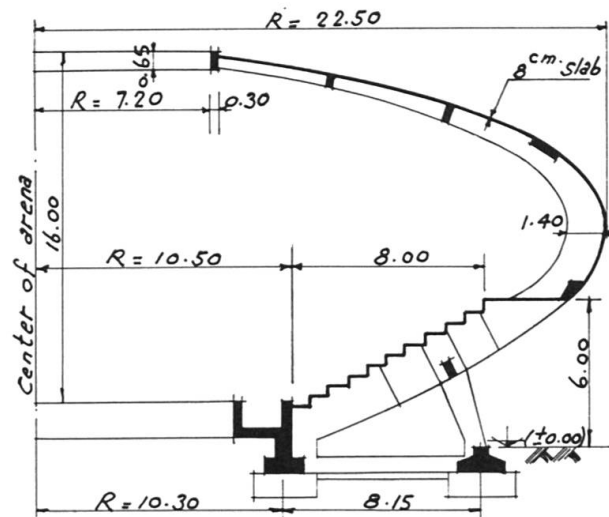

Arena, detail of radial frame

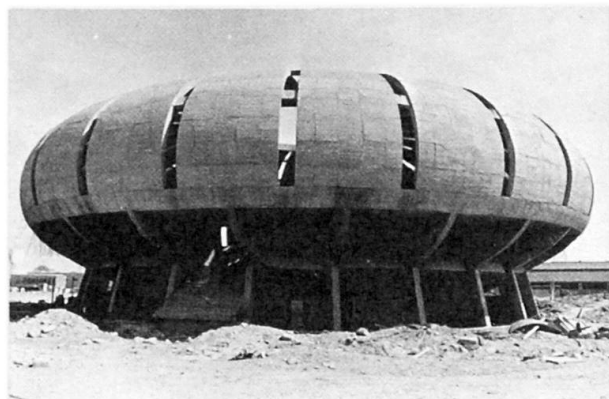

The arena