

**Zeitschrift:** IABSE reports of the working commissions = Rapports des commissions de travail AIPC = IVBH Berichte der Arbeitskommissionen

**Band:** 1 (1965)

**Artikel:** Prefabricated concrete building construction in the United States

**Autor:** McHenry, Douglas

**DOI:** <https://doi.org/10.5169/seals-945>

### **Nutzungsbedingungen**

Die ETH-Bibliothek ist die Anbieterin der digitalisierten Zeitschriften. Sie besitzt keine Urheberrechte an den Zeitschriften und ist nicht verantwortlich für deren Inhalte. Die Rechte liegen in der Regel bei den Herausgebern beziehungsweise den externen Rechteinhabern. [Siehe Rechtliche Hinweise.](#)

### **Conditions d'utilisation**

L'ETH Library est le fournisseur des revues numérisées. Elle ne détient aucun droit d'auteur sur les revues et n'est pas responsable de leur contenu. En règle générale, les droits sont détenus par les éditeurs ou les détenteurs de droits externes. [Voir Informations légales.](#)

### **Terms of use**

The ETH Library is the provider of the digitised journals. It does not own any copyrights to the journals and is not responsible for their content. The rights usually lie with the publishers or the external rights holders. [See Legal notice.](#)

**Download PDF:** 18.10.2024

**ETH-Bibliothek Zürich, E-Periodica, <https://www.e-periodica.ch>**

# Prefabricated Concrete Building Construction in the United States <sup>1)</sup>

*Bâtiments préfabriqués en béton aux Etats-Unis*

*Vorfabrizierte Hochbauten aus Beton in den Vereinigten Staaten*

## Introduction

Only within the past few years has prefabrication of concrete buildings <sup>2)</sup> become a prominent and even exciting part of the U. S. construction industry.

At the present time about 300 U. S. plants are producing precast concrete structural elements. The comparable figure ten years ago was much closer to 100. Precasting of concrete structural elements is by no means an innovation, for many prefabricated concrete building systems were devised and used to a very limited extent as early as the turn of the century. However, the added degree of freedom which is often provided by that technique, when combined with other advances in technology, is now being utilized as never before by architects, structural engineers, and building contractors. This added freedom extends in many cases throughout the entire project, from the initial concept by the architect through final erection by the building contractor.

The architect is achieving greater creativity through shapes and surface textures which would be difficult and costly for concrete cast in place; the structural engineer and the concrete technologist are thinking in terms of closer dimensional tolerances, higher strength materials, and better quality control; and the builder is finding greater freedom to reduce costs through reuse of forms and through simplified construction practices.

---

<sup>1)</sup> This report has been prepared by Douglas McHenry, Director of Development, Portland Cement Association, Skokie, Illinois, U.S.A.

<sup>2)</sup> This paper is limited to prefabricated buildings. Prefabrication of bridges in the U.S. has been discussed in two recent papers: "U.S. Research and Developments in Precast Bridge Construction", by Douglas McHenry, Third International Congress of the Precast Concrete Industry (1960); "Outstanding Structures in Prestressed Concrete Construction in the United States of America", by J. D. Piper, C. C. Zollman, and T. Y. Lin, Fourth Congress of the International Federation for Prestressing (1962).

In some respects the U.S. lagged behind Europe in the acceptance of prefabrication, which may appear surprising in view of leadership in mass production in many other industries. However, as has been stated elsewhere, the advantages of precasting of concrete extend beyond just the concept of manufacturing a member on the ground instead of up in the air, or on the river-bank instead of in midstream. The most effective precasting involves the mobilization of a number of technologies, and it is only recently that technological development reached a stage which made the method truly attractive to our particular economy. The technologies referred to include prestressing (both pretensioning and post-tensioning); improvement in quality and uniformity of materials; casting and compaction techniques; curing methods for rapid strength development; means of achieving texture and other effects on surfaces; means of joining the elements by welding, bolting, or in-place concrete; lifting equipment for getting the members into place; and others. Acceptance of innovations just for the purpose of doing something differently, or as an experiment, plays a part in our industry just as it does elsewhere; but in relation to the entire construction industry the part it plays is minor. Prefabrication of concrete is accepted when it offers a cost advantage in a highly competitive economy in which materials are plentiful and labor is costly and high quality is demanded. That advantage is becoming more common under the leadership of research, development and experience; but it is not infrequent that economic considerations may dictate a combination of precast and situ-cast concrete utilizing both conventional reinforcement and prestressing.

In this brief paper no attempt will be made to cover the field of

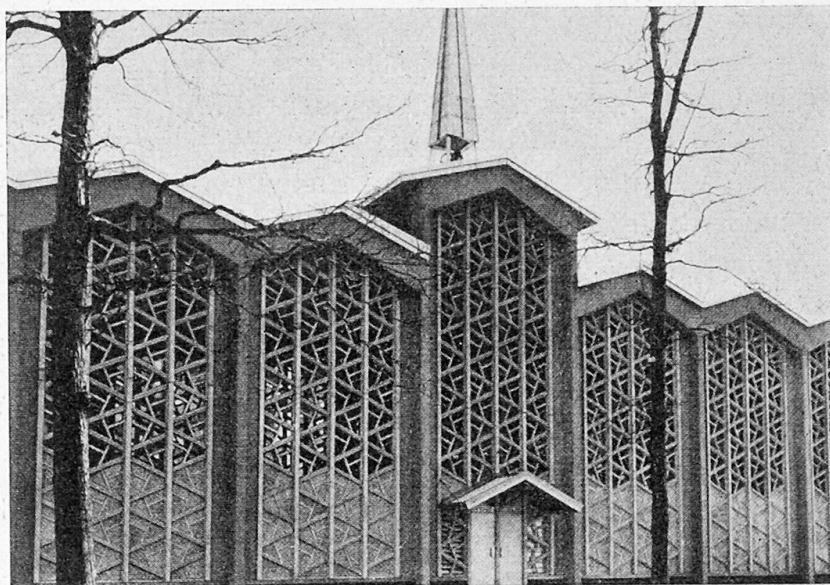

Fig. 1 - Capuchin Seminary. Architect: Charles D. Hannan. Engineer: Joseph Olivieri.



precast concrete in the U. S., nor to present an illustrated record of outstanding structures — the field is far too vast for that. Another difficulty in presenting a comprehensive view of precasting is that although we have building codes which are strictly enforced, we have little standardization of systems or of dimensions. Architects, engineers, and producers are all exercising fully the « freedom » which was mentioned earlier, and each is

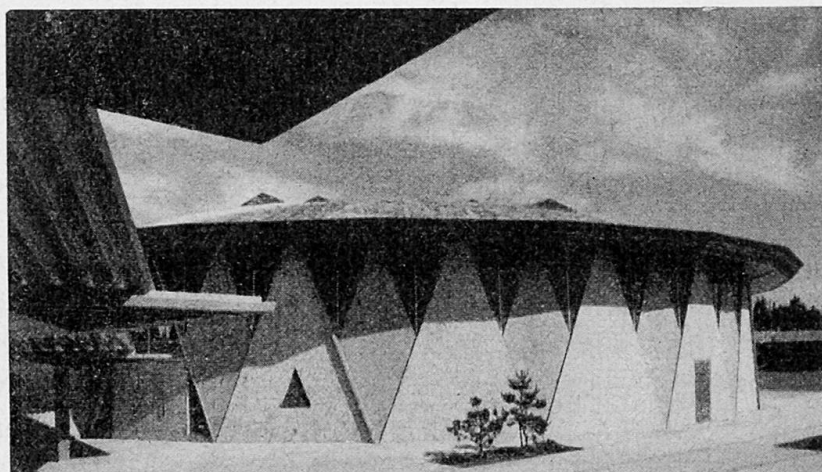

Fig. 2 - Terrace High School. Architect: Ralph Burkhard. Engineer: Anderson - Bjornstad - Kane.

exercising it in his own way. It is true that a strong trend exists toward the acceptance of certain dimensional modules, but not to the extent that architectural freedom is hampered. In fact, two trends are readily apparent in prefabrication: one toward full freedom of architectural expression; the other toward standardization. The view has been expressed that these two are competitive and one or the other must eventually be the winner; but there is no indication that such is the case. The two trends are not in opposition, and neither need yield to the other; both are here to stay.

The versatility which prefabrication offers is illustrated by Figures 1 and 2. Both are prefabricated concrete school buildings; the first is a Capuchin Seminary and the other is a public high school.

A great variety of structures fall between the modest buildings of Figs. 1 and 2 and the rather spectacular University of Georgia coliseum with its 380 - ft clear span. This structure employs the lamella rib system, in which 3,750 large precast concrete panels are tied together by cast-in-place ribs.

This wide variation in structural types is emphasized because it plays an essential role in all phases of prefabrication: design, production, erection techniques, and connection types.



### Materials

The materials used for prefabricated construction are in general the same as those used for conventional construction; but certain aspects of material usage have a pronounced influence on the acceptance and the growth of prefabrication, and these may be of general interest.

It appears that lightweight aggregate concretes are used for structural members to a greater extent in the U. S. than in other countries.

The use of such concrete for major structural elements is illustrated by Fig. 3, which shows erection of a precast girder of lightweight aggregate concrete spanning a distance of 98 ft. These 50-ton girders are almost one-third lighter than corresponding members of normal-weight concrete.

The lightweight aggregates for structural use are expanded clay, shale, slate, or slag. In a rather comprehensive investigation involving many lightweight aggregates suitable for structural concrete it was found that a 28-day compressive strength of 4500 psi for 6 × 12-in. cylinders could be achieved with six to eight 94-lb bags of cement per cu yd, compared with about five bags for a normal-weight aggregate. Unit weights of the various lightweight concretes varied from 90 to 110 lb per cu ft, as compared with about 145 lb for the regular concrete. With some lightweight aggregates compressive strengths as high as 9,000 psi have been achieved with 10 bags of cement per cu yd.

The modulus of elasticity of lightweight concretes is usually about one-half that of the heavier concrete of the same compressive strength. It may be estimated from the relationship

$$E_c = 33 W^{1.5} \sqrt{f'_c}$$

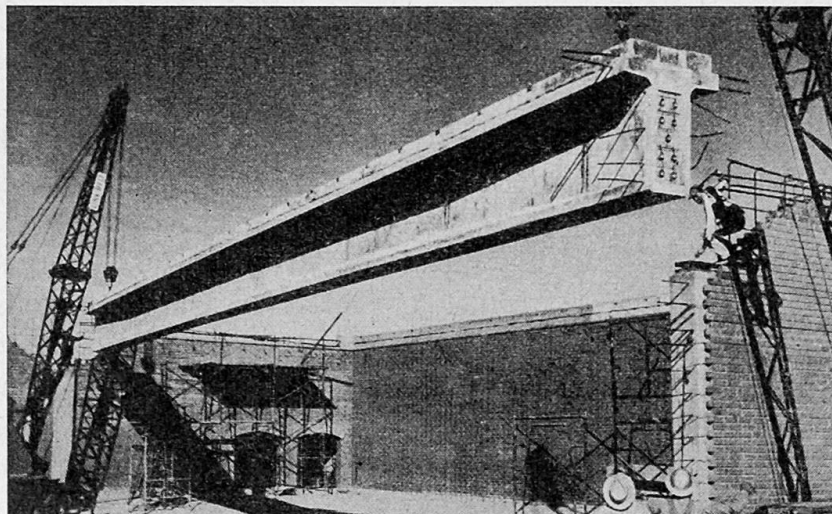

Fig. 3 - Lightweight Aggregate Girder 98 ft. Long.

where  $E_c$  is in lb per sq in.,  $W$  is the weight of the concrete in lb per cu ft, and  $f'_c$  is the compressive strength of  $6 \times 12$ -in. cylinders in psi. Natural sand is frequently used with lightweight coarse aggregate, in part to increase  $E_c$  and also to reduce the cost; but of course it also increases the weight. With respect to other properties, such as flexural strength, bond to reinforcing steel, drying shrinkage, and creep the two types of concrete show comparable values for equal compressive strength. Diagonal tension resistance is evaluated indirectly through the « split-cylinder » tension test, and the values assigned to lightweight concretes range from 60% to 100% of those for corresponding normal-weight concretes.

Manufactured lightweight aggregates are usually more costly than are natural aggregates, but as structural engineers are becoming more familiar with the properties of the lightweights they are finding that over-all building costs are frequently reduced. The improved thermal insulation provided by the lighter material is sometimes an important factor; and reduced weight in transporting and erecting precast members is likewise important.

Special surface colors or textures are obtained in prefabrication by use of a great variety of special aggregates, employing techniques which are not feasible for cast-in-place concrete. The opportunity for achieving the full range from subdued to striking or even garish effects is almost without limit. Large stones may be embedded in sand to provide a deep reveal; retarders may be applied to the forms or to the exposed surface for a light reveal; and of course chisels, bushhammers, and sand blasting are used. A fabric impregnated with retarder is now in successful use as a form liner. An innovation which shows promise as a form liner is a thin sheet composed of asbestos fibers and unhydrated cement. After casting the concrete, this sheet absorbs sufficient moisture for hydration of the cement, and it thus becomes an integral part of the member, with uniformity of color and texture provided to a degree which is difficult to achieve by other means. In the aggregate transfer method of precasting, the form is coated with an adhesive which holds the special aggregates in place during casting; interesting patterns and color-arrangements may thus be achieved. These techniques are used not only for members which are primarily decorative, but also for major load-bearing members.

Of the various types of cement available in the U. S., Types I and III are generally used for precasting. Type I is the cement used in general construction when special properties are not required. For Type III the chemical composition and fineness are adjusted so that strength develops more rapidly. A.S.T.M. specifications require a 3-day mortar cube strength of 3,000 psi for Type III, while the corresponding requirement for Type I is 1,200 psi. Type III cement is somewhat more costly, but in precasting plants it frequently results in economies through more frequent turn-over of equipment and of products. Physical properties of concretes made from the two cements, such as modulus of elasticity, creep, drying shrinkage,



tensile strength, are about equal for equal compressive strengths. Colored cements are not generally available, but white cement is used frequently for architectural reasons. Colors are achieved by adding pigments to the concrete mixtures.

Air entraining agents, either interground with the cement or added at the mixer, are used to improve the durability of practically all prefabricated elements which will be exposed to weathering in the colder climates. Proper air entrainment also improves workability and reduces bleeding and segregation; it permits some reduction in sand content and in water requirement. A loss in strength will occur if the amount of air exceeds established limits or if the concrete mixture is not adjusted to the proper sand and water contents. Recommended air contents range from 4% to 7%, depending on the maximum size of the aggregate.

Calcium chloride is frequently used as an accelerator to speed production. The quantity used is normally 2% or less by weight of the portland cement. However, this material is never used for prestressed concrete because of the danger of corrosion of the steel tendons. Other A.S.T.M. approved admixtures are sometimes used to improve workability or to reduce the water requirement, but such use should be preceded by tests using the actual job materials.

The main structural reinforcing bars in prefabricated members are invariably deformed in accordance with A.S.T.M. Designations A305 or A408. Welded wire or bar fabric is sometimes used for reinforcement, although its use in prefabrication is somewhat limited. A.S.T.M. standards for high strength reinforcing bars were issued in 1958-59, and the growing use of these bars with yield points of 60,000 and 75,000 psi, as compared with the customary 45,000 psi intermediate grade, is resulting in reduced cost of concrete members. If these bars are to be welded, special requirements must sometimes be met.

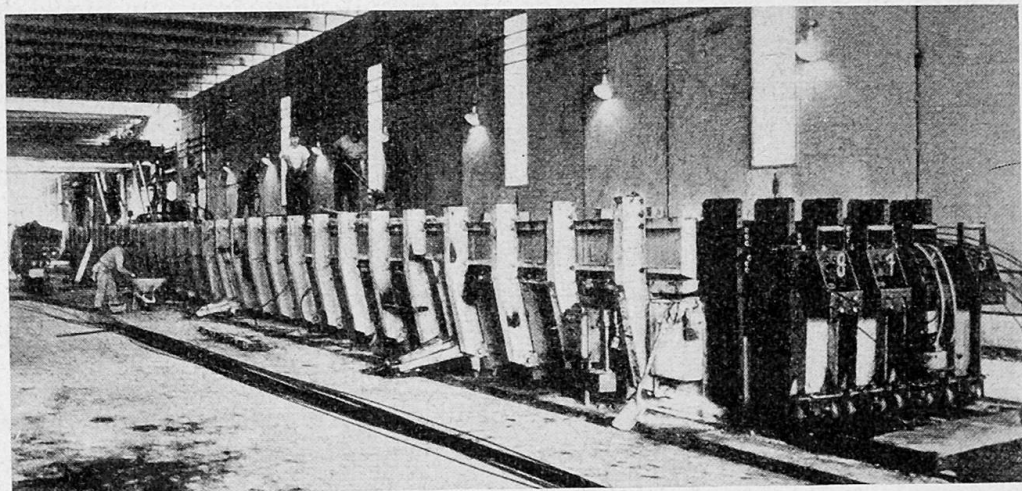

Fig. 4 - Production Machine for Prestressed Cored Slabs.



Prestressing tendons may be individual wires, strands, or rods. The stress relieved strand is perhaps the most common form of tendon, and it is used for pretensioning in diameters up to 1/2 in.

### **Production methods**

The methods used for producing prefabricated elements vary widely, from conventional forming and casting sometimes used when the members are fabricated on the site, to highly mechanized factory operations. The factory mass-production unit shown in Fig. 4 manufactures cored slabs 8 ft wide in lengths to 100 ft and in depths ranging from 8 to 24 in. The webs are pretensioned longitudinally, and the top and bottom flanges are pretensioned both longitudinally and transversely. A typical unit of this type, made of lightweight aggregate concrete, is shown by Fig. 5.

In another type of factory operation cored prestressed slabs 42 in. wide, 4 to 10 in. deep, are cast in lengths to 450 ft or more. Slabs are cast one above the other, using a dry mix which may be thoroughly compacted without bonding to the underneath slab. These slabs are then sawed to whatever lengths are needed. Many other systems are in use for automatic or semi-automatic production of smaller members.

Steam curing is used quite commonly to speed production. The optimum procedure for reuse of equipment every 24 hours involves a pre-steaming period of about 5 hours followed by steaming for 13 hours, with a maximum rate of temperature rise of 40°F per hour and a maximum temperature of about 150°F. This cycle thus allows 6 hours for stripping, cleaning forms, pretensioning, etc. A typical chart of strength development for various combinations of pre-steaming and steaming periods, all adding up to 18 hours, is shown by Fig. 6. The effect of steam curing on properties other than strength must of course be considered; and test data on creep and shrinkage have recently become available. Fig. 7 shows that for loading at equal strength levels steam cured concretes show less creep than those which are moist cured at 73°F. Steam curing also reduces shrinkage by amounts up to 15 per cent.

### **Erection and assembly**

#### *Erection Stresses*

Construction contracts in the U. S. are normally let on the basis of competitive bidding. The designer therefore does not ordinarily concern

himself with construction methods, but leaves that phase entirely to the successful bidder. In prefabrication, however, erection stresses, lifting techniques, sequence of making connections, and similar factors become an

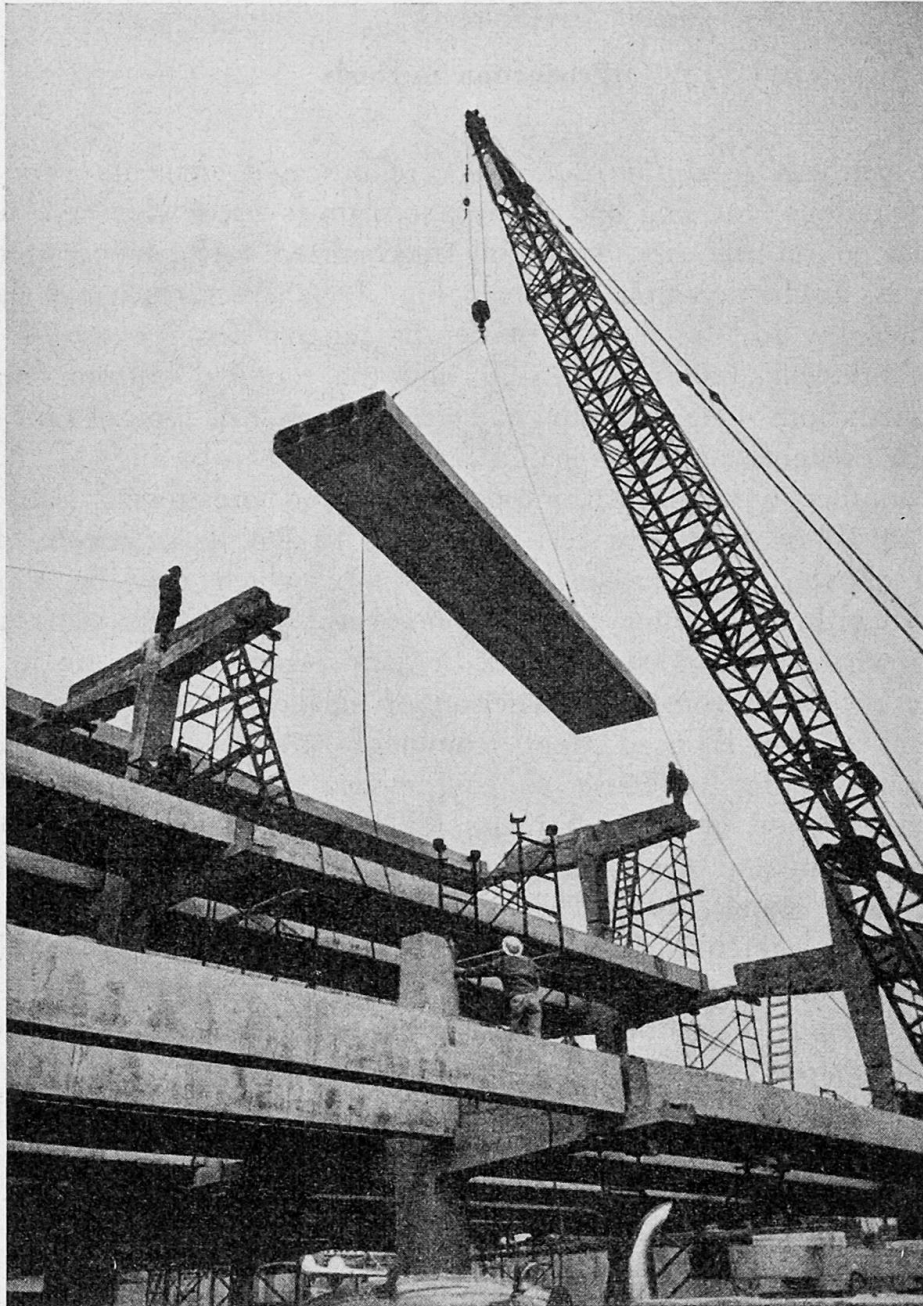

Fig. 5 - Erection of Cored Slabs.

integral part of the structural design. It is desirable that the contractor, with wide experience in construction methods, should work closely with the designer who must specify erection details; but under the bidding system this collaboration is often impossible. Many contractors employ



STRENGTH VS PRESTEAM PERIOD

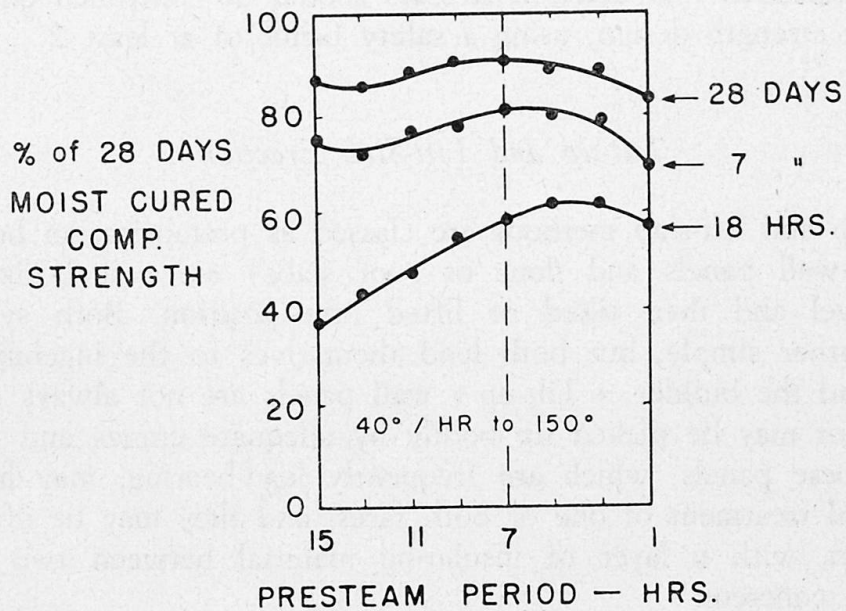

Fig. 6 - Strength Development Under Steam Curing.

structural engineers who, after the contract is let, may propose design changes to better suit the contractor's erection schemes.

Erection stresses are commonly permitted to exceed the maximum allowed for the completed structure. Reinforcing steel stresses may be permitted up to 75 % of the yield stress; and concrete stresses may reach

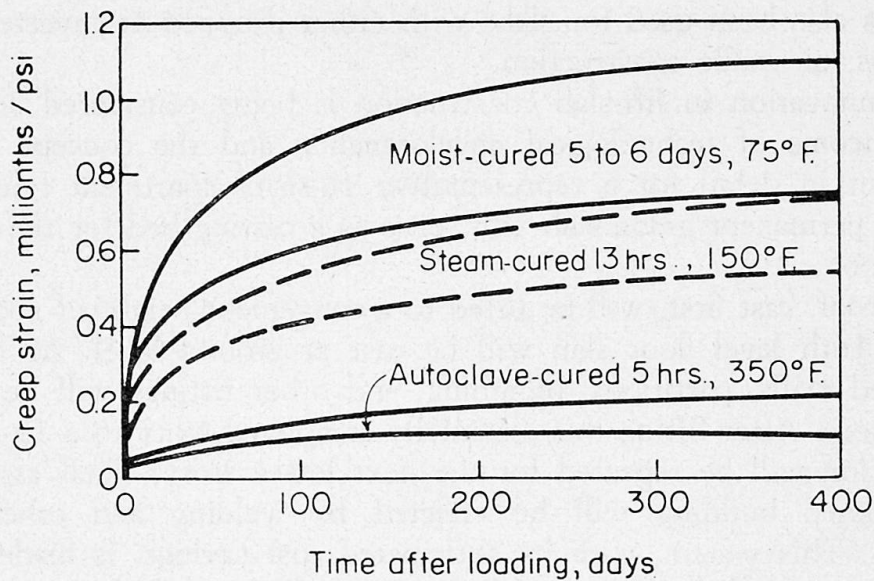

Fig. 7 - Effect of Curing on Creep of Concrete.



150% of the maximum allowed by standard building codes. In both cases the members should be considered as cracked sections. It has also been recommended that erection stresses should be controlled on the basis of ultimate strength design, using a safety factor of at least 2.

### *Tilt-up and Lift-Slab Erection*

Tilt-up and lift-slab methods are classed as prefabrication because the elements (wall panels and floor or roof slabs) are cast horizontally at ground level and then tilted or lifted into position. Both systems are basically rather simple, but both lend themselves to the ingenuity of the designer and the builder. « Tilt-up » wall panels are not always tilted into position, but may be picked up bodily by adequate cranes and positioned rapidly. These panels, which are frequently load-bearing, may incorporate architectural treatment of one or both faces, and they may be of sandwich construction, with a layer of insulating material between two layers of lightweight concrete.

The lift-slab method was introduced in a modest way in about 1950. It is now widely known and will be described only briefly. The lowest floor panel is cast in place, and this forms a bed upon which all other floors, plus the roof, are cast in stack formation. A common casting rate is one slab each two days. The slabs are then lifted into their final position by tension rods connected to hydraulic jacks located at the top of the columns. The earlier jacking equipment was designed for use with steel H columns, but has now been adapted for prefabricated concrete columns. Floor slabs are commonly the flat plate type (that is, a slab of uniform thickness) either prestressed or continuously reinforced. However, the system has also been used for slabs with either dropped or inverted beams, cored slabs, or waffle construction.

An innovation in lift-slab construction is being considered which is a logical outcome of technological developments, and the concept has been worked out in detail for a representative 16-story apartment building. As usual, the permanent grade slab will serve as a casting bed for the 16 floors and the roof.

The roof, cast first, will be lifted to a convenient height of about 15 ft. Next the 16th level floor slab will be cast at ground level. At this stage all required walls, partitions, plumbing, and other fittings will be installed for that story. After lifting this essentially completed story to a 15-ft height, the operation will be repeated for the next lower story. Final assembly of the completed building will be effected by welding and other joinery techniques. This system, with its anticipated cost savings, is made possible by the extremely close control of deflections which result from prestressing of all slabs and precise control of the lifting operation. It has been stated

that the lifting can be controlled to 0.01 inch. As is natural, it appears that similar concepts have developed in other parts of the world.

### *Connections*

One of the new technologies associated with prefabrication is that of connections. In this broad field almost unlimited opportunity exists for the exercise of ingenuity; but precise design criteria for connections are indeed limited. Research is now under way to provide such criteria, but the variables are so numerous that progress is necessarily slow. The following list includes the main functional categories of connections, all of which frequently occur in a single structure.

- 1 - Column - footing
- 2 - Wall - column
- 3 - Girder - column
- 4 - Girder - wall
- 5 - Beam - girder
- 6 - Slab - beam

The various types of connections are listed below, but it must be recognized that many variations occur within each type.

- 1 - Site Concrete
- 2 - Welded
- 3 - Prestressed
- 4 - Steel insert
- 5 - Bolted
- 6 - Doweled
- 7 - Re-bar coupled
- 8 - Adhesive

Because of labor conditions it is usually desirable to limit the types used in a single structure. For example, if welding is used at all it is ordinarily economical to use it extensively.

The Prestressed Concrete Institute has issued a tentative manual on Connection Details for Precast-Prestressed Concrete Buildings which includes 49 detail drawings of connections. A few of these are shown in the schematic drawing, Fig. 8.

Erection and connection schemes for precast structures vary so widely



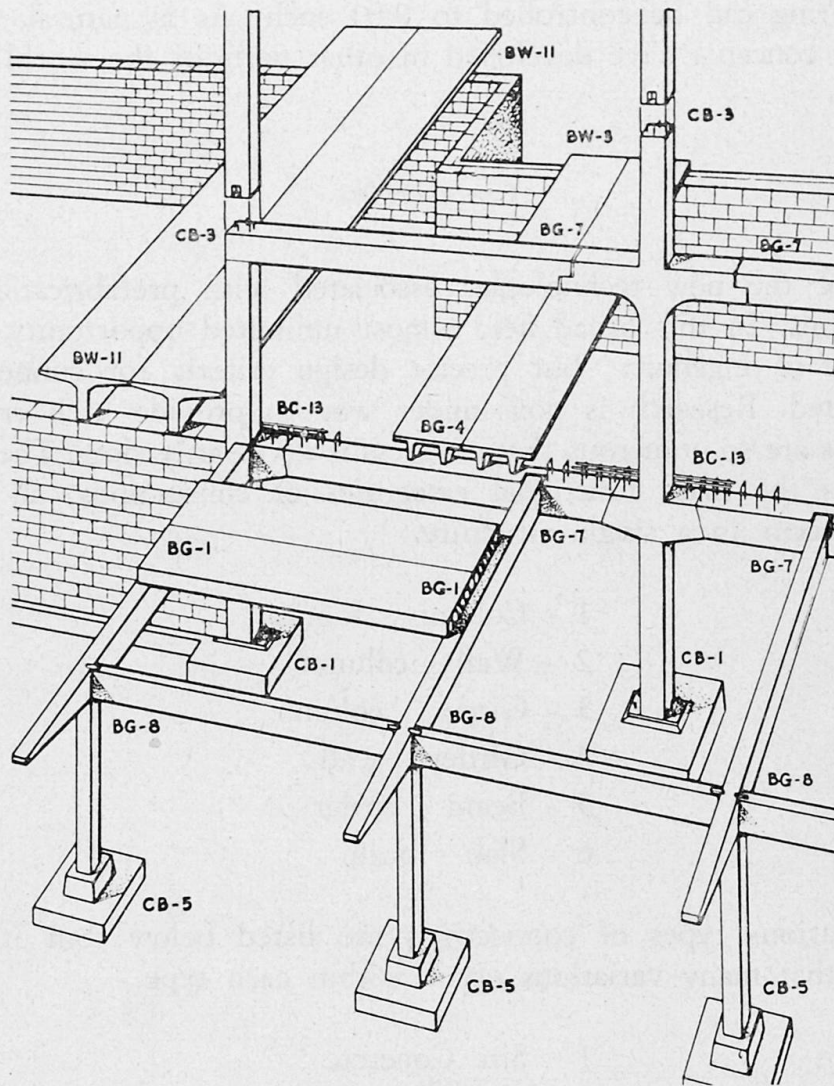

Fig. 8 - Typical Connections.

that it is impossible to select a truly « typical » system. As an illustration, Fig. 9 shows the system that was devised for two-story barracks buildings for the U. S. Coast Guard. The four principal elements are prestressed double-T floor beams, insulated wall panels, drop-in spandrels, and roof spandrels. The various elements were assembled, starting with the cast-in-place grade beam in the order in which they are numbered in Fig. 9. The prefabrication, delivery, and erection were so scheduled that 39,000 sq ft of floor space were fully enclosed in 29 working days.

A principal requirement in joinery is that dimensional changes due to drying shrinkage, temperature change, and creep must be accommodated. Such changes may, among other effects, introduce horizontal force components at bearing surfaces with an accompanying reduction in bearing strength. Experience has shown that properly detailed monolithic structures can accept



such dimensional changes with no impairment of serviceability. The same can certainly be said of properly detailed prefabricated structures; but the background of research and experience is not yet adequate to assure such proper detailing without study of each individual case.

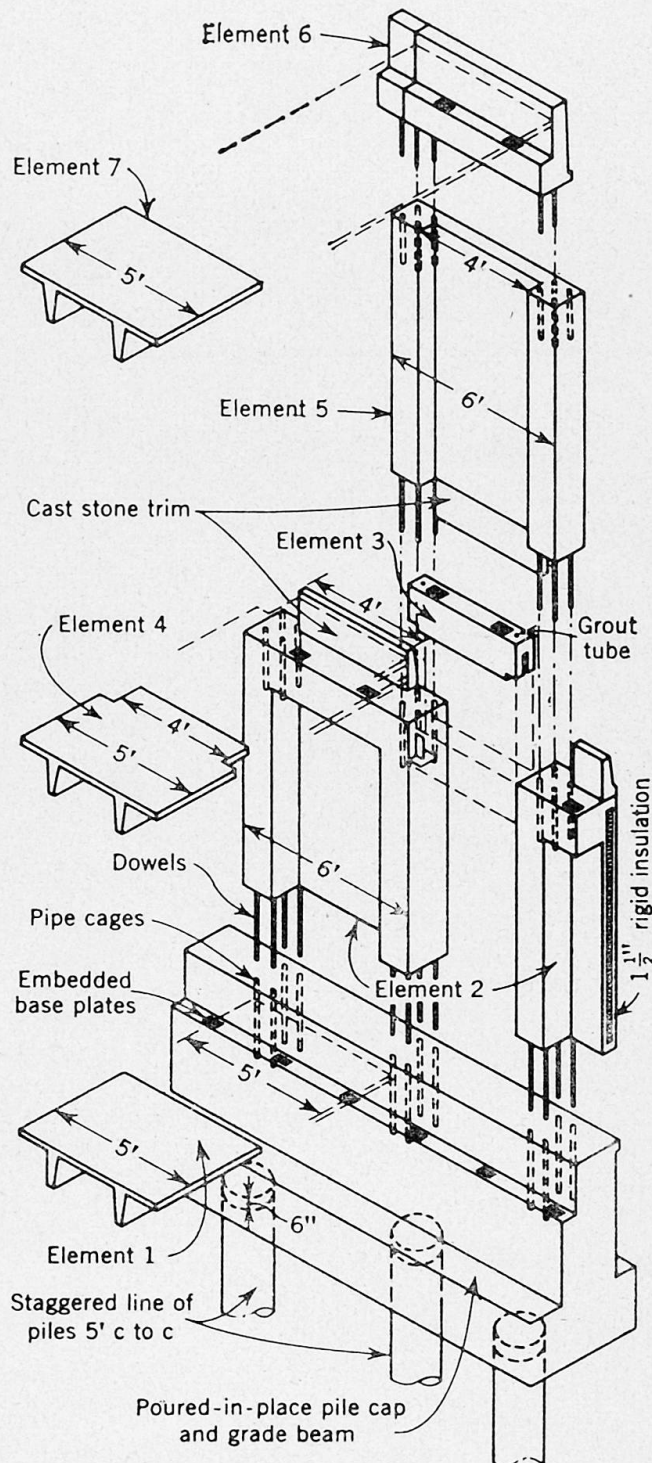

Fig. 9 - Assembly of Prefabricated Elements for Two-Story Barracks Building. Architect and Engineer: George M. Ewing Co. (Illustration courtesy "Civil Engineering").

Leere Seite  
Blank page  
Page vide