

Zeitschrift: IABSE reports of the working commissions = Rapports des commissions de travail AIPC = IVBH Berichte der Arbeitskommissionen

Band: 5 (1970)

Artikel: Shrinkage and creep strains obtained from measurements on actual structures

Autor: Swamy, Narayan / Bennett, Neil

DOI: <https://doi.org/10.5169/seals-6910>

Nutzungsbedingungen

Die ETH-Bibliothek ist die Anbieterin der digitalisierten Zeitschriften. Sie besitzt keine Urheberrechte an den Zeitschriften und ist nicht verantwortlich für deren Inhalte. Die Rechte liegen in der Regel bei den Herausgebern beziehungsweise den externen Rechteinhabern. [Siehe Rechtliche Hinweise.](#)

Conditions d'utilisation

L'ETH Library est le fournisseur des revues numérisées. Elle ne détient aucun droit d'auteur sur les revues et n'est pas responsable de leur contenu. En règle générale, les droits sont détenus par les éditeurs ou les détenteurs de droits externes. [Voir Informations légales.](#)

Terms of use

The ETH Library is the provider of the digitised journals. It does not own any copyrights to the journals and is not responsible for their content. The rights usually lie with the publishers or the external rights holders. [See Legal notice.](#)

Download PDF: 15.10.2024

ETH-Bibliothek Zürich, E-Periodica, <https://www.e-periodica.ch>

Shrinkage and Creep Strains Obtained from Measurements on Actual Structures

Mesures de contraction et de fluage effectuées sur des constructions actuelles

Schwind- und Kriechdehnungen aus Messungen an bestehenden Bauwerken

NARAYAN SWAMY

NEIL BENNETT

Department of Civil and Structural Engineering

University of Sheffield

England

INTRODUCTION This paper is a preliminary report of a current investigation on the shrinkage, creep and temperature movements of certain structural members in a reinforced concrete building during construction and, later, in the completed structure. It is the first part of a research programme to attempt to predict the possible movements of actual structural members from laboratory scale models. The instrumentation was commenced about a year ago and measurements have been made during various stages of construction. As the full designed loads have yet to be imposed, and the laboratory model tests are only about to commence, no attempt is made at this stage either towards correlation of data or prediction of creep and shrinkage coefficients.

Details of the structure. The instrumented building forms part of the development programme of the University of Sheffield. The building consists of a central six-storey block, surrounded by seven hexagonal blocks each of three storeys. The eleven reinforced concrete columns which have been instrumented form part of the structural system of the central block. In general, the most highly stressed columns based on the accessibility of the faces in the completed building have been chosen.

Columns 1 - 7 are in the basement at level 0; they are made of white Portland Cement, washed grit sand and shap granite, with mix proportions of 1:1.75:3.1 with a water/cement ratio of 0.46. Columns 8 - 11 are on the ground floor at level 1, and are made of ordinary Portland cement, washed grit sand and crushed Derbyshire limestone in 1:1.96:3.49 mix proportions with a water/cement ratio of 0.50. All the aggregates were continuously graded with a maximum size of 19mm. The reinforcement in the columns consisted of hot-rolled deformed (and weldable) high yield steel with a minimum yield stress of 420 N/mm² (60,000 lbf/sq.in.).

Instrumentation. The columns have been instrumented as follows:

1) acoustic strain gauges to measure internal strains and temperature, 2) surface gauge points for use with a 200 mm. Demec mechanical gauge, 3) internal gauge points on steel reinforcement for use with a 200 mm. Demec gauge, and 4) photo-elastic stress plugs.

Each column is fitted with two 140 mm. long vibrating wire gauges, near the upper and lower ends of the column. The gauges are of the Building Research Station type and were embedded in briquettes of concrete using a mix of identical

materials and proportions to the field mix. The briquetting was carried out as soon as practicable before "casting in". Their surfaces were roughened to increase the bond with the structural concrete, and the gauges were installed vertically along the central longitudinal axis of the column. The Demec gauge points on the column surfaces were fixed contiguously along the centre line of each face over the height of the column. Sometimes all four faces were not available for strain measurement. The steel gauge points were fixed at regular intervals along the column through bright steel connecting pieces brazed to the steel reinforcement.

Control specimens - 150 mm. cubes and 150 mm. dia. x 300 mm. cylinders or 100 mm. x 100 mm. x 500 mm. prisms - were also cast for each column for compressive strength and shrinkage tests. The control cubes were cured (1) under water and (2) under the same exposed temperature and humidity conditions as the columns. Shrinkage on control specimens were measured with 200mm. Demec gauge under (1) controlled temperature and humidity conditions, (2) uncontrolled laboratory conditions and (3) the same conditions of exposure as the columns in the structure.

Test Results. All the vibrating wire gauges are working satisfactorily. Many surface gauge and internal steel gauge points were knocked off during construction and subsequent finishing processes. Nevertheless a great amount of field data has been acquired and these are now being supplemented by laboratory scaled tests. Because of the early stage of the investigation, it is thought appropriate to present only factual data, and tentative conclusions, which may be modified in the light of subsequent analysis and results.

Many field problems arise regarding instrumentation and measurement during construction, but these are not discussed here. In the discussion below only data pertaining to columns 2 and 3 at level 0 and columns 10 and 11 at level 1, which represent the two different types of concrete used, are presented. Columns 2 and 3 were cast together, whilst columns 10 and 11 were cast on consecutive days.

Concrete strength. Although the mixes for the columns were designed for a cube strength of 31N/mm^2 (4,500 lbf/sq.in.) at 28 days, the actual cube strengths were much higher. The standard deviation for the 28-day cube tests were: 5N/mm^2 for water-cured specimens and 3.60N/mm^2 for exposed specimens respectively.

Typical average cube results for columns 2, 3, 10 and 11 are shown below.

Location	Age. days	Cube strength N/mm^2	
		Water-cured	Exposed
COLUMNS 2 & 3	28	52.0	38.6
	180	--	62.3
COLUMNS 10 & 11	28	62.6(48.5*)	53.4
	210	--	71.0

* strength of 100 mm. cubes cast from laboratory mix used for briquettes.

The results confirm the well-established fact that the control cube strength depends on the method of curing. The results also show that there is likely to be considerable divergence between in-situ structural strength and the normal control specimen strength, and that it is unlikely that tests on laboratory specimens would show the same deformations as the field movements unless the two strengths and exposure conditions are readily comparable.

Behaviour of Columns immediately after casting. Because of inevitable delays at site, and partly due to weather, the briquettes containing acoustic gauges were at different ages at the time the columns were cast. They were generally cured in water prior to fixing at site. With columns 2,3 and 10,11, the briquettes were

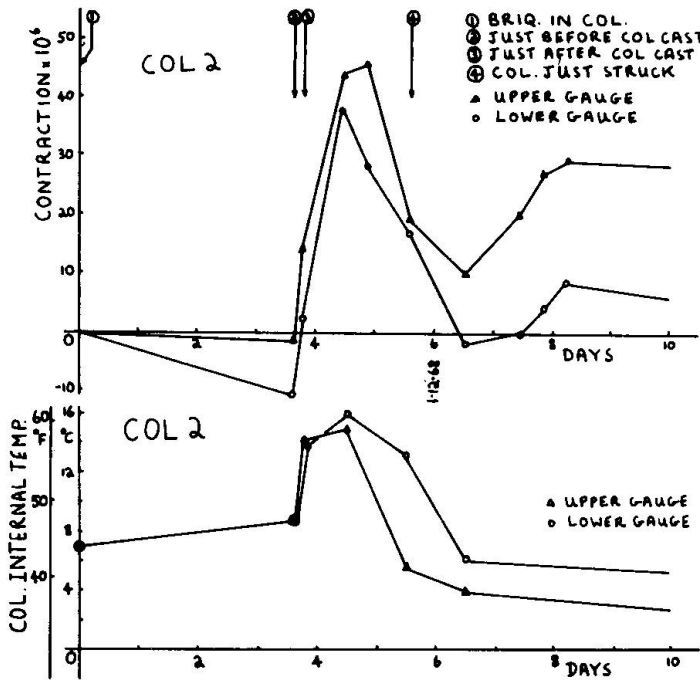

Fig. 1.

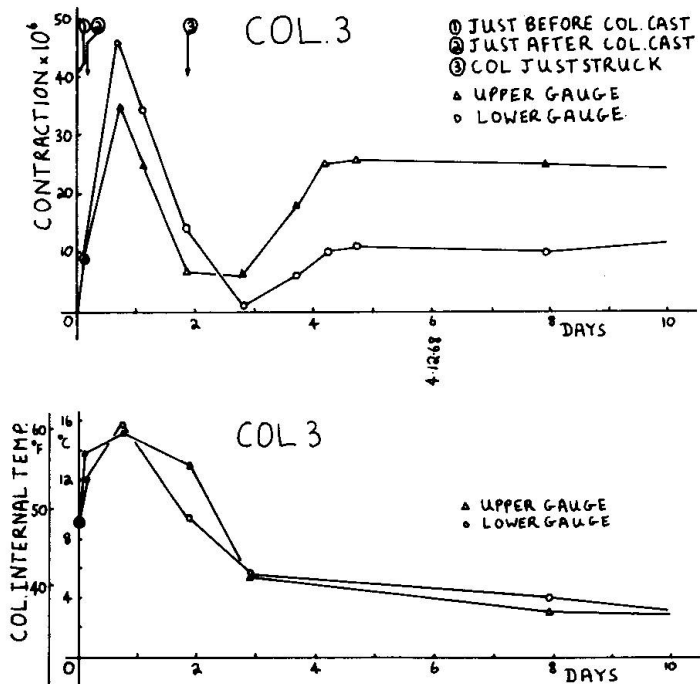

Fig. 2.

cularly for limestone. It is also suspected that the initial contraction observed in columns 2 and 3 is partly due to the differential age between the structural concrete and the briquette, which would initially behave like a relatively stiff inclusion in a soft matrix.

Shrinkage of Control Specimens. The free shrinkage of the control specimens from Columns 2,3 and 10,11 are shown in FIGS.5 and 6. Each point on the graphs is the average of two specimens - six readings for columns 2 and 3 and eight readings for columns 10 and 11. These curves show that (1) the shrinkage of specimens in the laboratory and constant temperature room is very similar, the former being higher by about 10 per cent, (2) the shrinkage of limestone concrete is less than that of shap granite in spite of the fact that the limestone concrete

respectively 9 days and 18 hours old when the columns were cast. The strain and temperature variations in these columns prior to and after casting are shown in FIGS 1,2,3 and 4.

All the columns 1 to 11 were cast during the winter of 1968 and the gauges, inevitably, showed differences in their behaviour in the various columns. In general, the briquettes which had been cured for some time showed an immediate contraction on removal from the curing tank and fixing in the form-work, but these contractions were of small magnitude (FIGS. 3 and 4) the maximum contraction being about 70×10^{-6} mm/mm.

Immediately after casting the gauges in columns 2 and 3 showed longitudinal shrinkage during setting and hydration, the greater value of shrinkage occurring at the upper or lower end of the column (FIGS. 1 and 2). This movement ceased after 15 to 24 hours, and the gauges subsequently showed an expansion of about 40 to 45×10^{-6} mm/mm for about 2 days, during which time the internal temperature fell by about 10°C and then became stabilized to the ambient temperature.

The gauges in columns 10 and 11 showed immediate expansion after casting, due to the hydration of the cement. In column 11 the formwork was left for a week after casting, and the resulting expansion continued for six days, with a maximum value of 90×10^{-6} mm/mm (1,2).

In addition to volume changes, the recorded movements include some thermal movements due to the different coefficients of expansion of the wire and the concrete, parti-

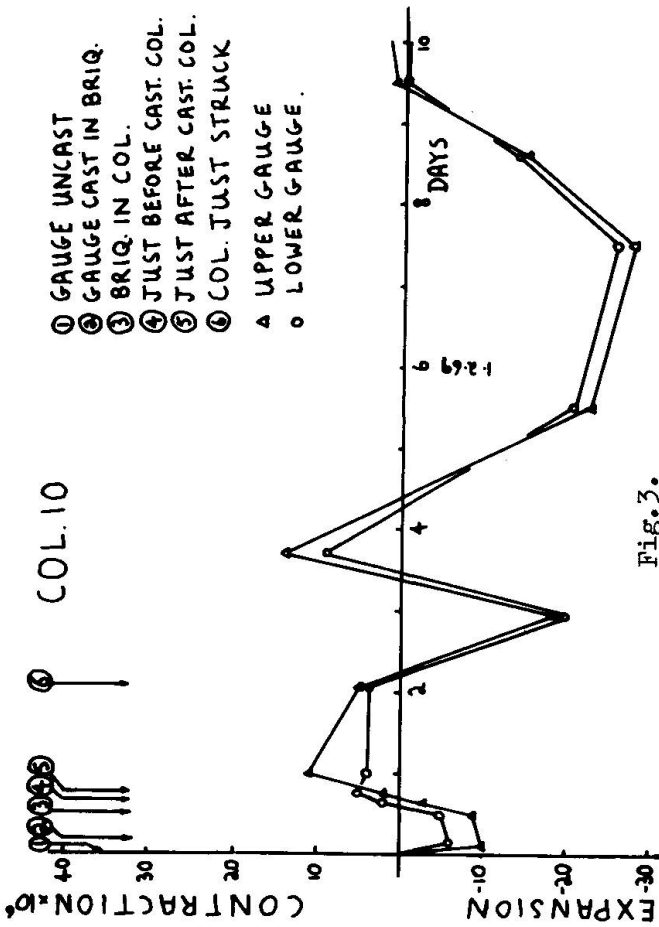

Fig. 3.

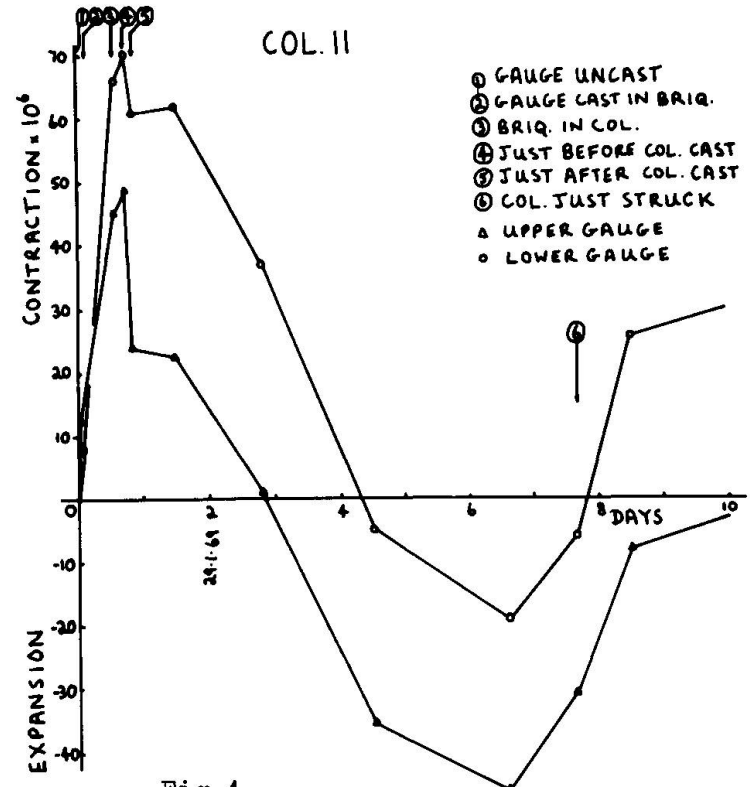

Fig. 4.

specimens have about 30 per cent higher surface area/volume ratio over that of the granite specimens, and (3) the specimens cured externally show the least shrinkage; the variation is erratic particularly in the winter months, but shows a consistently upward trend at later ages.

During the initial stages of hydration, the laboratory specimens showed shrinkage values of 6 to 7 times that of the exposed specimens. At the age of one year, however, the differences decreased and the exposed specimens showed a shrinkage of less than half of that of the corresponding specimen cured in the controlled room. This divergence between site and laboratory conditions makes correlation of data difficult. In addition, the size effect and corrections for temperature for the Demec readings have to be considered before relating these shrinkage data to site measurements.

Movement of in-situ structural columns. The strain readings obtained from the acoustic gauges, the surface gauge points and the internal steel gauge points in columns 2, 3 and 10, 11 are shown in Figs. 7 and 8. The external temperature and humidity conditions since the start of the project is shown in Fig. 9 together with the internal temperature in the columns obtained from the acoustic gauges. In general all the measured individual values varied slightly but for the columns cast together they were close enough to be averaged. Each point on the surface strain graph measured on the faces of columns represents the mean of about 36 readings for columns 2 and 3 (Fig. 7) and the mean of about 50 readings for columns 10 and 11 (Fig. 8). The steel strains were initially measured on at least 8 gauge points for each column, but a number of these were dislodged during various stages of construction.

Part of the dead and live loads during construction were first imposed on columns 2 and 3 at the age of 56 days, and on columns 10 and 11 at the age of about 70 days (Figs. 7 and 8). The strains up to this age there

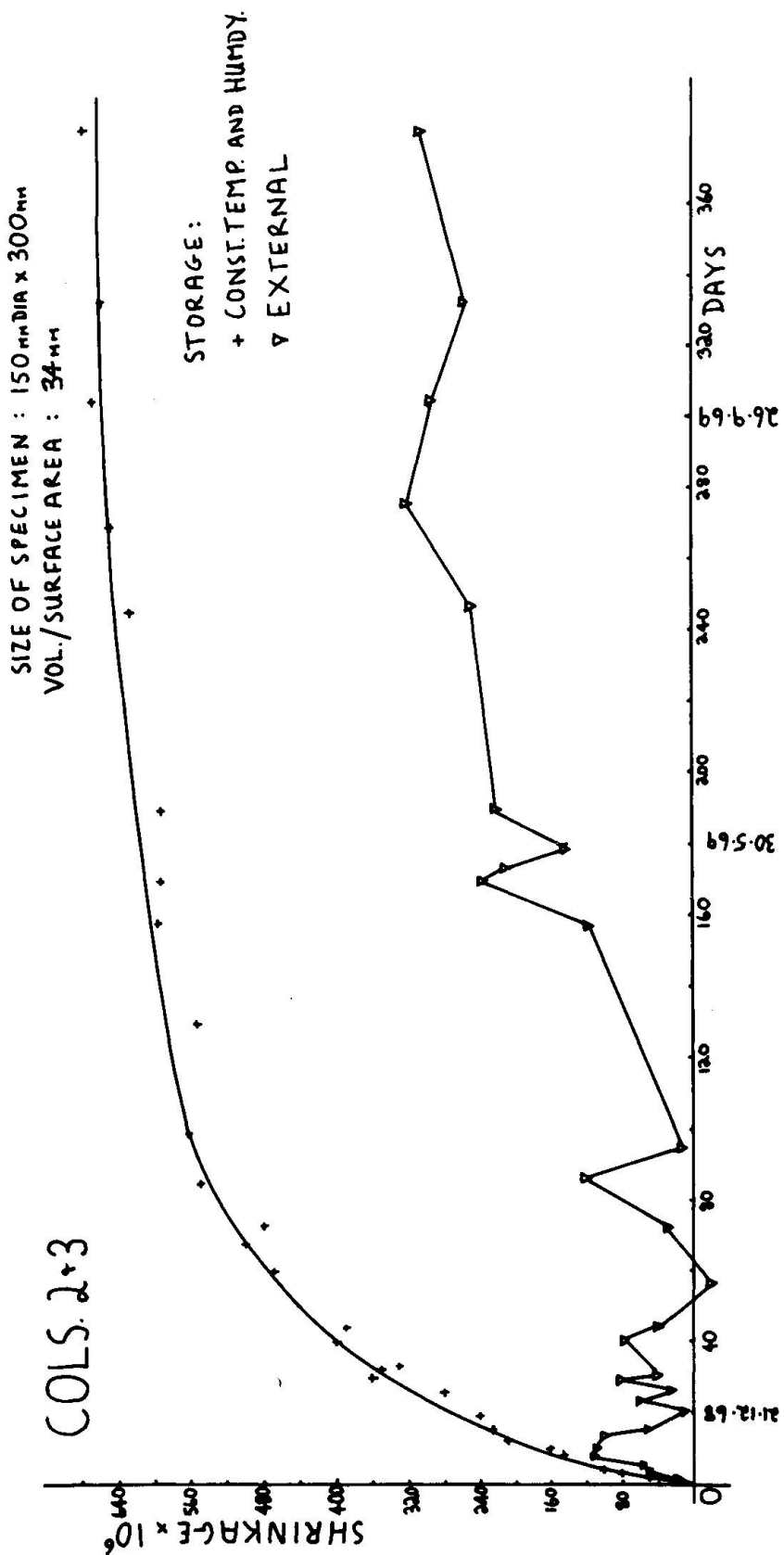

fore represent the shrinkage and temperature movements, whereas the subsequent values represent the total movement including the elastic, shrinkage and creep strains. Although all the gauges show considerable fluctuation during the initial stage of movement up to about 40 days, the subsequent overall strain and temperature variations show a consistent pattern, and generally follow the ambient temperature and humidity changes and showing the existence of a clear correlation between the two.

The strain variations up to the first loading stage show that the internal strains from acoustic gauges in the columns were nearer to the shrinkage strains of the exposed control specimens than to the shrinkage strains of the laboratory control specimens. The surface strains on the faces of the columns showed greater differential movement because of the non-uniform environmental conditions. In general, all the in-situ strains were of low magnitude compared to the shrinkage of laboratory control specimens, partly due to the high humidity and low temperature of the winter months.

The total measured movements (without corrections) at the end of about a year are shown in Figs. 7 and 8 for columns 2,3 and 10,11 respectively. The greater part of the movement seems to

have occurred in the first two-hundred days, during a period of low humidity and high ambient temperature, when most of the construction of the upper floors was carried out. The approximate time-scale when the loads from the upper storeys can be deemed to be transferred to the columns is shown in Fig.7. For columns

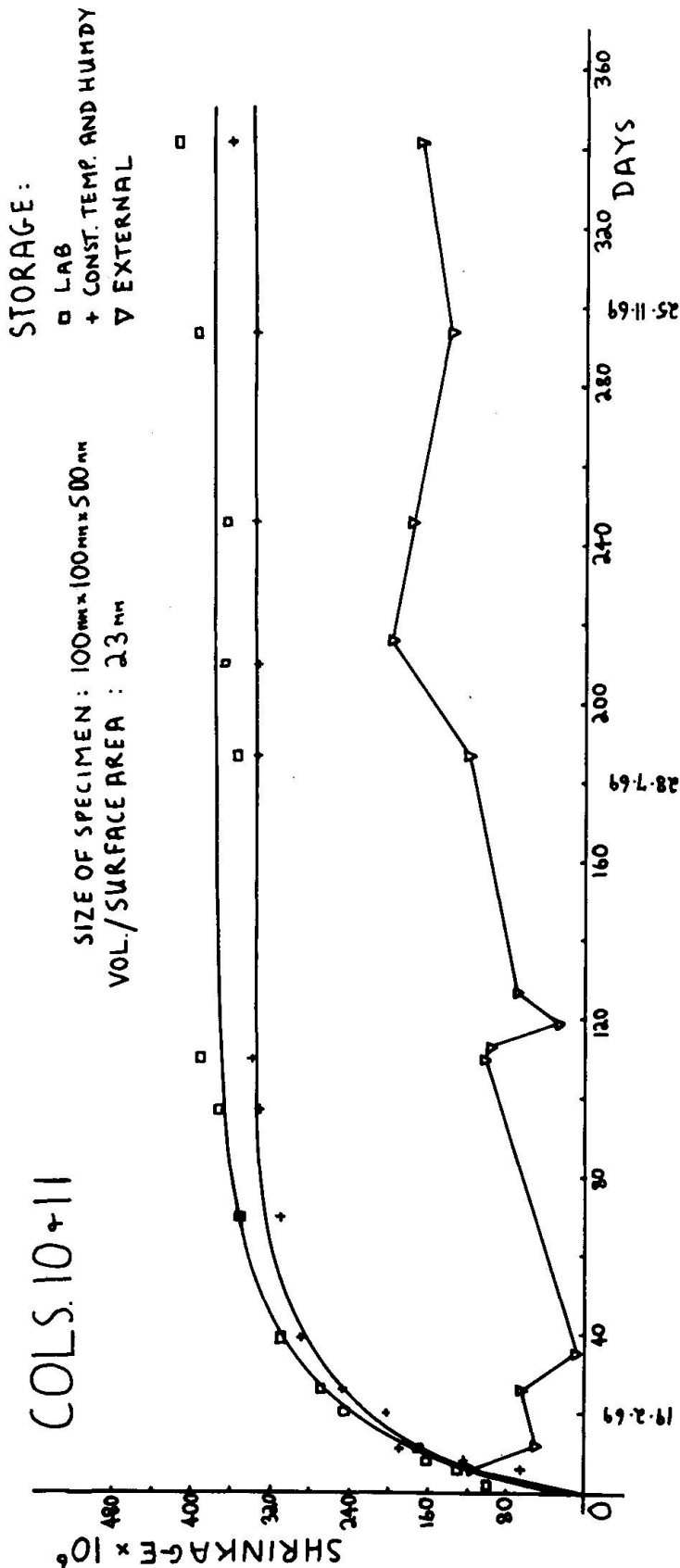

2 and 3, the recorded strains represent the elastic, shrinkage and creep strains, since the coefficient of expansion of the acoustic gauge wire roughly corresponds to that of the concrete. For limestone concrete, the recorded strains need some correction for temperature due to differences in the coefficient of expansion of the wire and concrete, although these corrections would be of small magnitude (Fig.9).

The recorded total movement of the upper and lower acoustic gauges for all the columns over a period of 400 days is shown below.

Col.	Age	STRAIN	
		U.Gau.	L.Gau.
1	405	152	80
2	406	277	185
3	406	303	199
4	397	163	64
5	356	184*	213*
6	339	204	114
7	344	180	145
8	349	395	369
9	348	357	397
10	345	393	413
11	344	293	333

Fig.6.

*Column 5 was cast in three lifts. The lower gauge is in the first lift where the column is integral with a wall. The upper gauge is in the third lift of stronger concrete.

The results show that for columns 1 to 8 (excluding 5), the greater movement occurs in the upper part of the columns where the concrete is likely to be weaker due to bleeding and possible segregation due to overvibration. The differences in strain between the upper and lower ends can be over 100%. This trend is seen to be reversed in columns 9 to 11, in which the upper gauges show a lower strain. The table also shows that limestone concretes show a greater total movement than granite concretes. Apart from the surface area-volume ratio and the actual stresses on the columns, shrinkage

and creep also depend on the elastic modulus of the aggregate, and limestone aggregate is known to show greater creep than other aggregates generally used.

Variation of Internal Temperature. The temperature increases were generally of the same order for columns 2,3 and 10,11 and hence the results are plotted togeth-

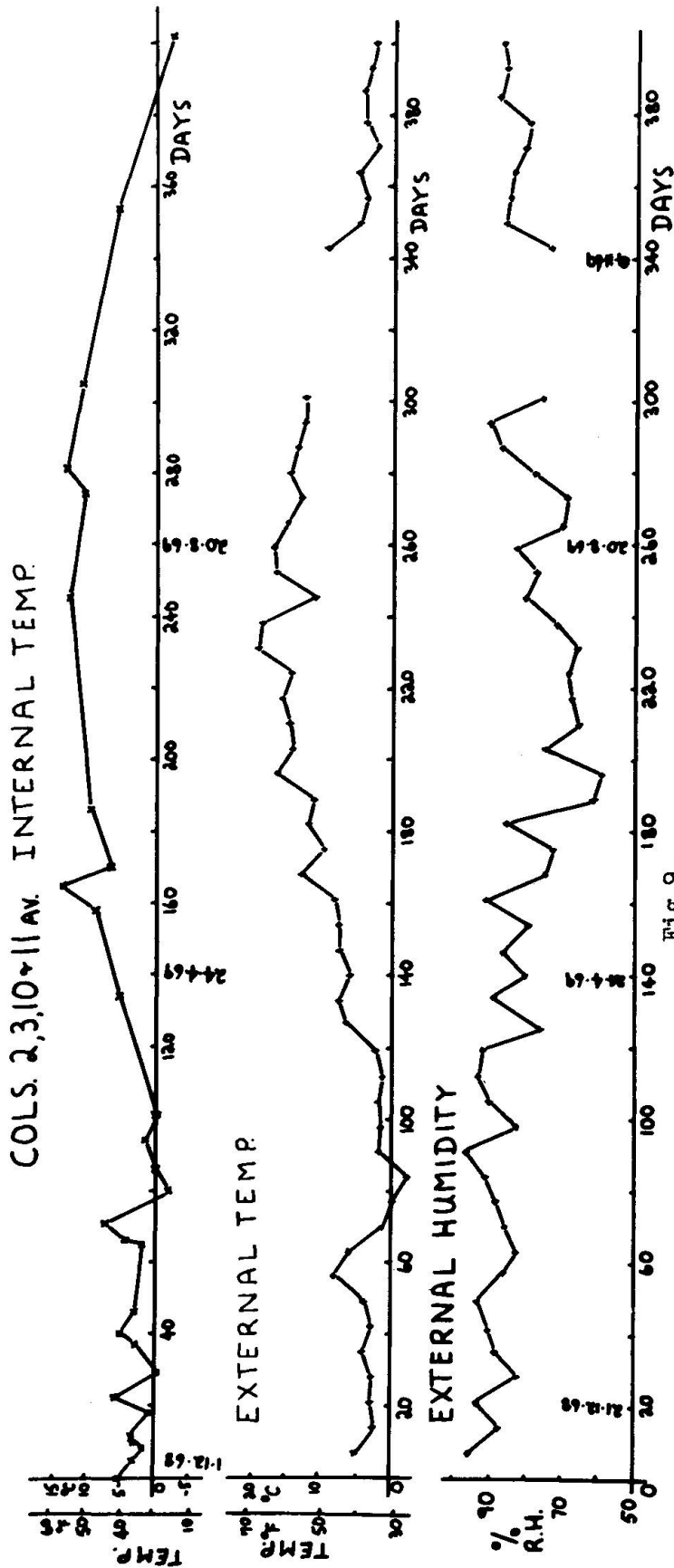
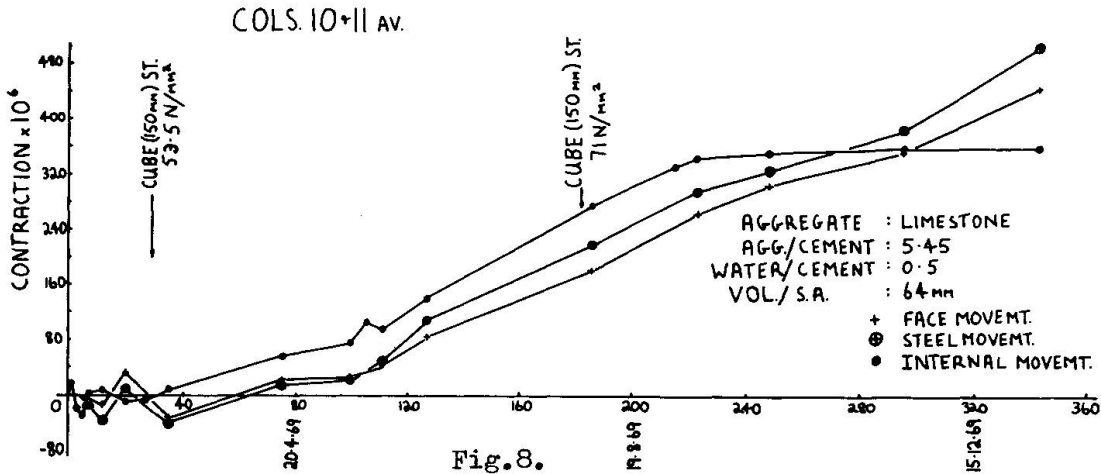
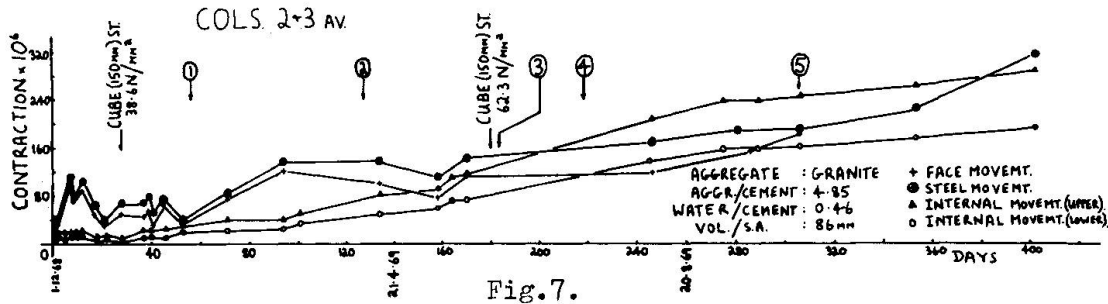

Fig.9.

er in FIG.9. Each point on the ambient temperature and humidity chart in Fig.9 represents the weekly averages. Although the internal temperature shows initial fluctuations due to exposed conditions, over a period of time the column temperature follows the pattern of variation of the external temperature. The results show that the temperatures of normal reinforced concrete structures in service are unlikely to differ greatly from the ambient. However, the temperature history in restrained structural members is important as it could induce stresses which would give rise to additional creep. The maximum temperature recorded in the columns was about 14°C, and the minimum about -3°C at the age of 400 days. The surface of the columns will generally be at the outside temperature, and therefore there is likely to be a temperature gradient between the inside and outside of the columns. When the inside temperature is higher, this will accentuate the internal shrinkage and reduce the surface shrinkage. As the internal temperature drops, the surface shrinkage begins to pre-dominate over the internal strains (Fig.8). Since drying shrinkage cannot penetrate far into the interior, there is bound to be some differential movement between the faces, as was observed in columns 2 and 3. The variation of internal temperature in the columns shows that, in general, the drying shrinkage movement is of greater importance than the thermal movement.

Internal Steel Strains. The measured steel strains in columns 2,3 and 10,11 are shown in Figs.7 and 8. Up to about 40 days, the steel strains showed considerable fluctuation. In columns 2 and 3, the strains remained compressive, whereas,

in columns 10 and 11, tensile strains of up to 40 μ s were recorded during the initial period of hydration. The maximum steel strains recorded were 310 μ s in columns



2 and 3 at 400 days, and 500 μ in₂ columns 10 and 11 at 340 days, corresponding to steel stress of about 59.8 N/mm² and 96.5 N/mm² respectively. No attempt is made in this paper to evaluate the distribution of load between the concrete and steel in these columns.

References

1. Browne, R.D. and McCurrich, L.M., Conf. on Prest. Conc. Press:Vessels, London, March 1967.
2. Tyler, R.G., Highway Research Record, 218, 1968.

Acknowledgement

To Professor Eastwood for his encouragement; to Messrs. Lowe and Rodin, to the Architects, and to Messrs. George Longden and Son Ltd. for their assistance.

Summary

This paper describes the first part of a research programme to predict the movements of in-situ structural members from laboratory scale models. Changes of strain measured from field gauges during casting and various stages of construction over a period of one year are described and discussed.

Résumé

Cet article décrit la première partie d'un programme de recherche visant à prévoir les mouvements d'éléments de structure sur des modèles de laboratoire. Les variations temporelles de tension ont été mesurées avec des jauges pendant la coulée et à des étapes différentes de la construction. Ces variations, intervenues au cours de la période d'une année, sont ici décrites et analysées.

Zusammenfassung

Dieser Artikel beschreibt den ersten Teil eines Forschungsprogrammes, um Bewegungen von Bauteilen an Labormodellen vorauszusagen. Zeitliche Spannungsänderungen, die mit Messelementen während des Betonierens und zu verschiedenen Herstellungsstufen über die Zeitspanne eines Jahres festgestellt wurden, werden beschrieben und diskutiert.