

Zeitschrift: IABSE reports of the working commissions = Rapports des commissions de travail AIPC = IVBH Berichte der Arbeitskommissionen

Band: 14 (1973)

Rubrik: Free discussion

Nutzungsbedingungen

Die ETH-Bibliothek ist die Anbieterin der digitalisierten Zeitschriften. Sie besitzt keine Urheberrechte an den Zeitschriften und ist nicht verantwortlich für deren Inhalte. Die Rechte liegen in der Regel bei den Herausgebern beziehungsweise den externen Rechteinhabern. [Siehe Rechtliche Hinweise.](#)

Conditions d'utilisation

L'ETH Library est le fournisseur des revues numérisées. Elle ne détient aucun droit d'auteur sur les revues et n'est pas responsable de leur contenu. En règle générale, les droits sont détenus par les éditeurs ou les détenteurs de droits externes. [Voir Informations légales.](#)

Terms of use

The ETH Library is the provider of the digitised journals. It does not own any copyrights to the journals and is not responsible for their content. The rights usually lie with the publishers or the external rights holders. [See Legal notice.](#)

Download PDF: 06.10.2024

ETH-Bibliothek Zürich, E-Periodica, <https://www.e-periodica.ch>

DISCUSSION LIBRE • FREIE DISKUSSION • FREE DISCUSSION

Low-Cycle Fatigue of Concrete in Compression. A Method of Experimental Investigation

Fatigue à basse fréquence de béton comprimé. Méthode d'une recherche expérimentale

Nieder-zyklische Ermüdung von komprimiertem Beton. Methode einer experimentellen Untersuchung

J. KRCHOV V. ČERVENKA
 Building Research Institute
 Prague, CSSR

An experimental investigation of low-cyclic fatigue of concrete in compression is in progress at the Building Research Institute of Technical University in Prague at present. The experiments are performed on prisms 15x15x40 cm with constant rate of strain-loading (speed: $\frac{\Delta\varepsilon}{\Delta t} \doteq 0,4 \cdot 10^{-3} \cdot \text{min}^{-1}$). The most difficult problem associated with this type of experiment is the determination of the upper limit of cycling load P_m for each specimen. The value of P_m is in the interval from 0,85 to 0,95 of ultimate strength P_U . From number of methods attempted, the method of recording of volume-strains proved to be most useful.

On the curve of the usual stress-strain diagram $P \times \varepsilon$ only the point of ultimate strength P_U can be clearly defined. However, on the corresponding volume-strain-stress diagram $P \times \frac{\Delta V}{V}$ two other points can be defined (Fig.1): P_C - load under which concrete has minimum volume, P_0 - load under which volume strain is of zero value. By these two points is in fact limited the interval of low-cyclic fatigue.

It follows from results of pilot experiments that between values of P_C , P_0 and P_U , relations exist, which permit sufficiently reliable estimate of stress-state of specimen. The histograms of ratios P_C/P_U and P_0/P_U are shown in Fig.2.

The comparison of relations $P \times \varepsilon$ and $P \times \frac{\Delta V}{V}$ is illustrated by two examples. Fig.3 shows these diagrams for a case

of failure after five cycles of loading (spec.No65). The case of specimen (No71) which survived 20 cycles of loading is shown on Fig.4. From these examples can be seen that the curve $P \times \Delta V/V$ provides more useful information for this investigation, comparing to ordinary stress-strain diagram.

It should be emphasized that record of volume strains can be used also for evaluation of results. Results of pilot tests of about 40 specimens are shown in Fig.5. Number of cycles n_f leading to failure of concrete is plotted against the ratio v_{m1}/v_c defining the upper limit of cyclic loading (the meaning of parameters is clear from figure).

These preliminary results indicate that relation between number of cycles leading to failure and upper limit of cyclic loading defined by volume strains exists. The same result follows from ratio of number of failed (full points) and unfailed (blank points) specimens, plotted at three levels of cyclic loading (Fig.5).

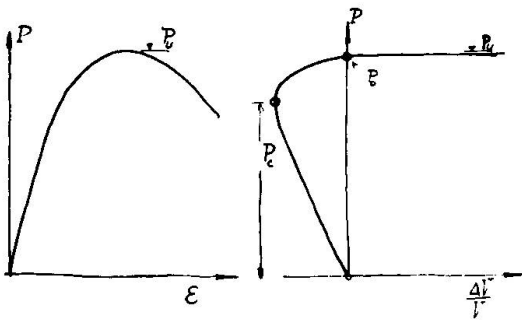

Fig.1 Stress-strain diagram and volume-strain-stress diagram

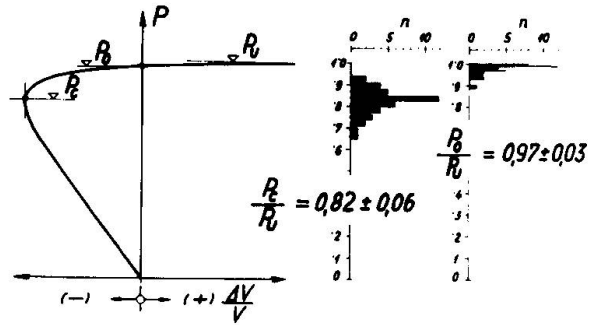

Fig.2 Characteristics of volume-strain-stress diagram

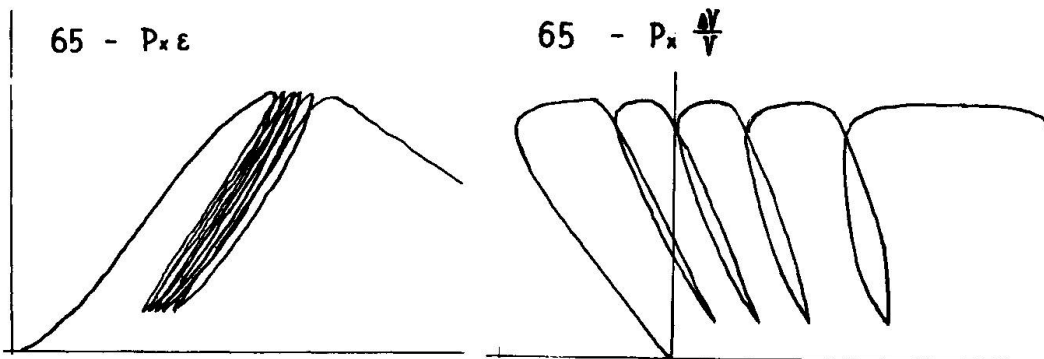

Fig.3

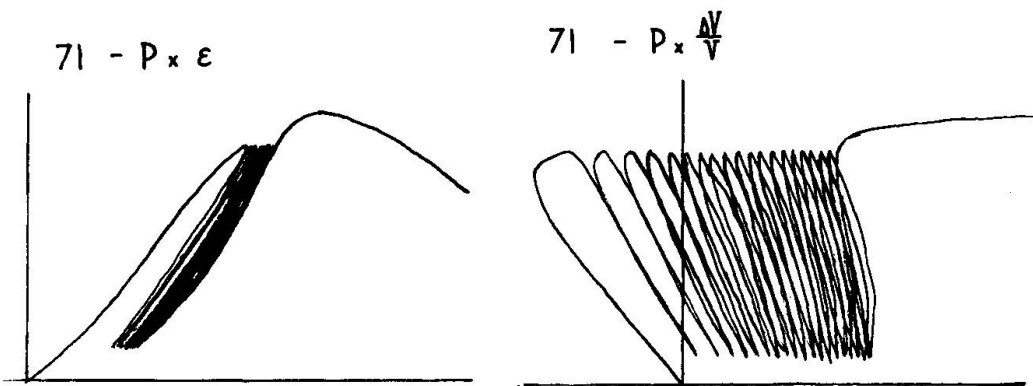

Fig.4

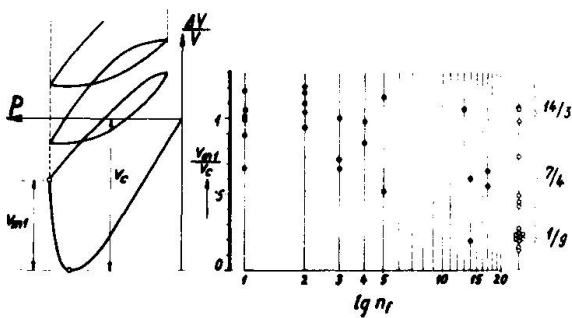

Fig.5 Experimental results of pilot tests

- - failed
- - unfailed

SUMMARY

The volume strain of concrete is a suitable parameter describing the behaviour of concrete specimens under cyclic loading. The use of volume-strain/stress-curves enables to perform low-cycle fatigue tests with acceptable reliability of reaching failure at a required number of cycles.

RESUME

Le changement de volume du béton constitue un paramètre utile pour décrire le comportement d'éprouvettes en béton sous charges cycliques. L'utilisation de courbes changement de volume/charge permet d'exécuter des essais sur cycles à basse fréquence avec une fiabilité admissible en atteignant la ruine au nombre de cycles requis.

ZUSAMMENFASSUNG

Die Volumenbeanspruchung von Beton ist ein geeigneter Parameter zur Beschreibung des Verhaltens von Betonprobekörpern unter zyklischer Belastung. Die Verwendung von Volumenbeanspruchung/Spannungs-Kurven erlaubt die Durchführung von Versuchen für nieder-zyklische Ermüdung mit annehmbarer Zuverlässigkeit beim Erreichen des Versagens bei einer verlangten Anzahl von Zyklen.

IV

Hysteresis Loops of Reinforced Concrete Elements subjected to Reversed Cyclic Axial Loading

Boucles d'hystérésis d'éléments en béton armé soumis à l'inversion d'une charge cyclique axiale

Hystereseschleifen von Stahlbetonelementen unter Einwirkung zyklischer axialer Wechselbelastung

W.S. RUMMAN Ru-Tsung SUN
Associate Professor Doctoral Student
Department of Civil Engineering
The University of Michigan
Ann Arbor, Michigan, USA

INTRODUCTION

The research presented herein was a by-product of a study dealing with moment-curvature hysteresis loops of reinforced concrete members having a hollow circular cross-section as shown in Figure 1.

Members of this type are encountered in reinforced concrete chimneys and in bridge piers. As these members are subjected to an axial force and a cyclic bending moment, a longitudinal element such as A in Figure 1 will experience an alternating axial force that will fluctuate between compression and tension. Although it is possible to obtain hysteresis loops for such an element by using already established loops for concrete in compression and for steel in both compression and tension, it was felt that this approach neglects many factors such as the effect of the cracking of the concrete, the bond failure and the spalling of the unconfined concrete. To account for such factors it was decided to perform experimental tests on longitudinal elements subjected to axial cyclic loads. The purpose of this contribution is to present results of tests made on longitudinal elements 2 1/2" x 2 1/2" in cross-section reinforced with four longitudinal bars, and to compare the experimental results with hysteresis loops derived theoretically.

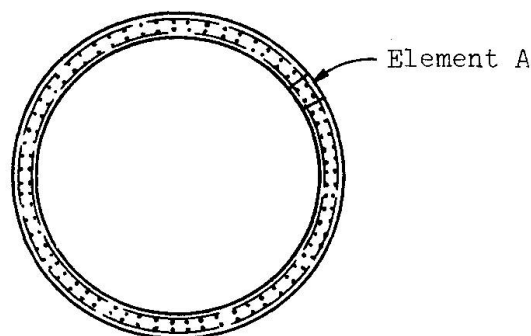

Figure 1
Hollow Circular
Cross-section

EXPERIMENTAL INVESTIGATION

Figure 2 shows the details of the specimens that were used in the experimental investigation. The size of the cross-section was limited to 2 1/2" x 2 1/2" because of the 50 kips capacity of the testing machine used. The specimens were reinforced by No. 2 reinforcing plain bars made of mild steel with a yield point of 55000 psi. The ties with a diameter of 0.0625 inches were made of iron wire with a yield stress of about 30000 psi. The concrete was made of regular Type I Portland cement and well-graded sand.

Two dial gages mounted between two rods that were placed in the concrete as shown in Figure 2 were used on two opposite sides of each specimen. The loading on the specimen was applied at such a rate as to allow for the continuous reading and recording of the load and of the displacement. It should be mentioned that the average reading of the two dial gages was used in plotting the results of the tests.

THEORETICAL INVESTIGATION

Hysteresis loops for load versus strain on each element were established analytically by using hysteresis loops for steel [1,2] and concrete [3] that were previously established and used by many investigators. These hysteresis loops for steel and concrete are given in Figures 3 and 4 respectively. The hysteresis loops for plain concrete as given in Figure 4 include the factors K_1 and K_2 which are measures of the deterioration of the concrete when subjected to cyclic loading. The assumed value of K_1 that was used in the analytical investigation was primarily based on the results of the tests.

The modulus of elasticity of the concrete, E_c , was evaluated by using the ACI Building Code (ACI 318-71) formula:

$$E_c = w^{1.5} 33 \sqrt{f'_c}$$

where f'_c = concrete strength as obtained from cylinder tests in lbs/sq. in.
and w = weight of the concrete in lbs/cu.ft.

The theoretical hysteresis loops that were generated using a computer program, have the same controlled load values or controlled strain values at the turning points as those of the experiments.

RESULTS

Although a total of nineteen elements were tested, only the results of three tests are given in this paper. The experimental results are given in Figures 5a, 6a and 7a and the corresponding theoretical results are given in Figures 5b, 6b and 7b. The results are plotted as the axial load on the specimen in kips versus the strain. The specimen of Figure 5a had a tie space of 1 inch while those of Figures 6a and 7a had a tie spacing of 2 inches.

The specimen of Figure 5a was subjected to controlled strain that fluctuated from .0015 in compression to .0068 in tension. In Figure 6a, the fluctuation of strain was approximately from .0016 in compression to .0100 in tension. The specimen of Figure 7a was tested with controlled loading that varied from about 35 kips in compression to about 11 kips in tension. Included in Figures 5a and 6a are additional diagrams that give the variation in the maximum compressive load as a function of the number of cycles. Similarly, an additional diagram giving the variation in the maximum compressive strain as a function of the number of cycles is plotted in Figure 7a. The dashed curves in Figures 5b, 6b, 7b represent the loops that would be obtained for all the cycles beyond the first if no deterioration in the concrete is assumed (i.e., $k_1 = k_2 = 1.0$).

DISCUSSION AND CONCLUSIONS

In general, the experimental hysteresis loops were in good agreement with the analytical hysteresis loops. It should be mentioned, however, that the assumed deterioration factors in the concrete that were used in the analytical approach were derived mainly from the experimental data.

It can be stated that analytical procedures can be used to predict hysteresis loops of reinforced concrete elements subjected to cyclic axial loading if sufficient tests are performed to establish degradation coefficients.

REFERENCES

1. Agrawal, G. L., Tulin, L. G., and Gerstle, K. H., "Response of Doubly Reinforced Concrete Beams to Cyclic Loading," ACI Journal, Proceedings Vol. 62, No. 7, July 1965, pp. 823-836.
2. Singh, A., Gerstle, K. H., and Tulin, L. G., "The Behavior of Reinforcing Steel under Reversed Loading," Material Research and Standards, Vol. 5, No. 1, Jan. 1965, pp. 12-17.
3. Kent, D. C., "Inelastic Behavior of Reinforced Concrete Members with Cyclic Loading," Thesis presented to the University of Canterbury, Christchurch, New Zealand, 1969, in partial fulfillment of the requirement for the degree of Doctor of Philosophy.

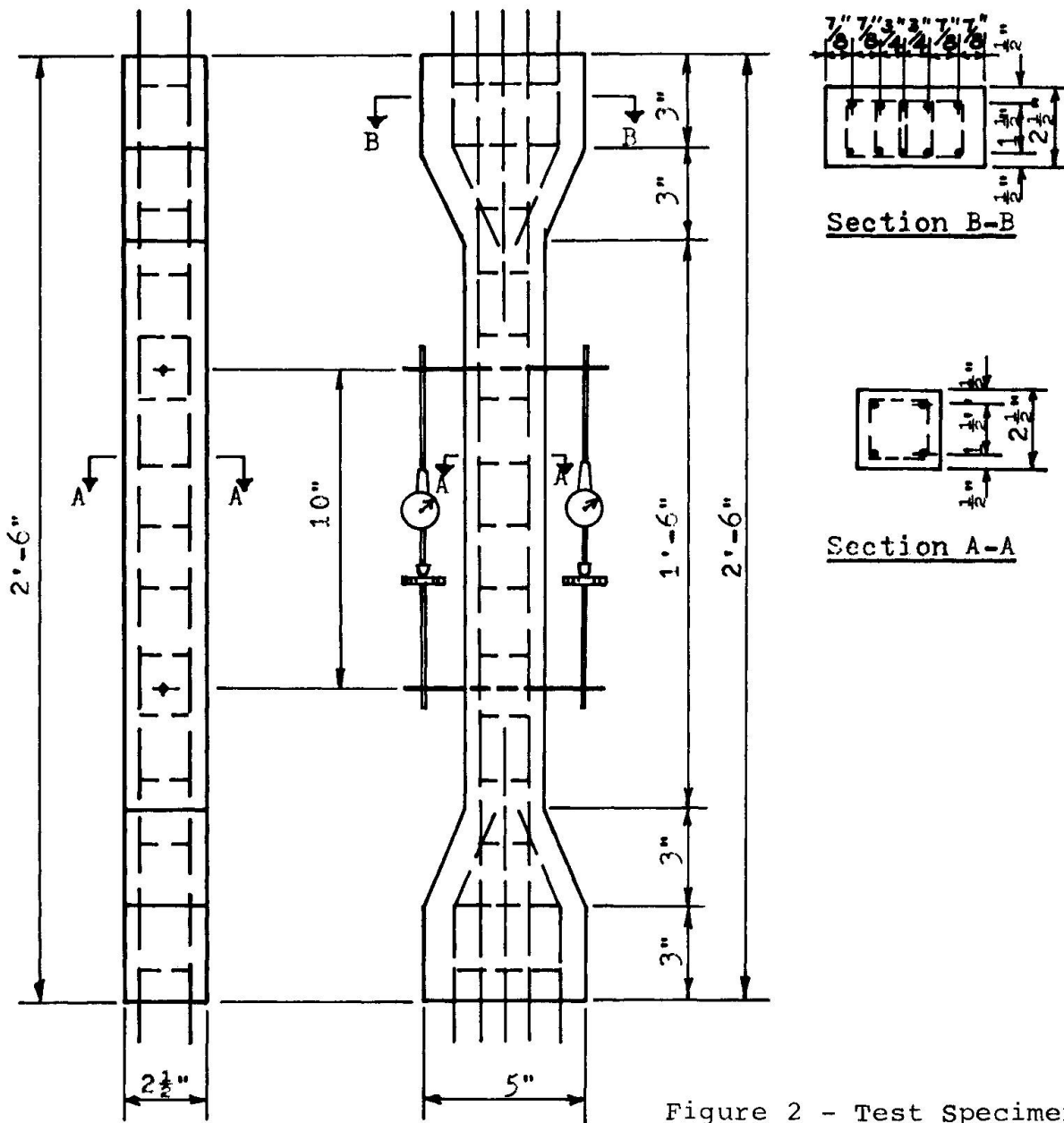

Figure 2 - Test Specimen

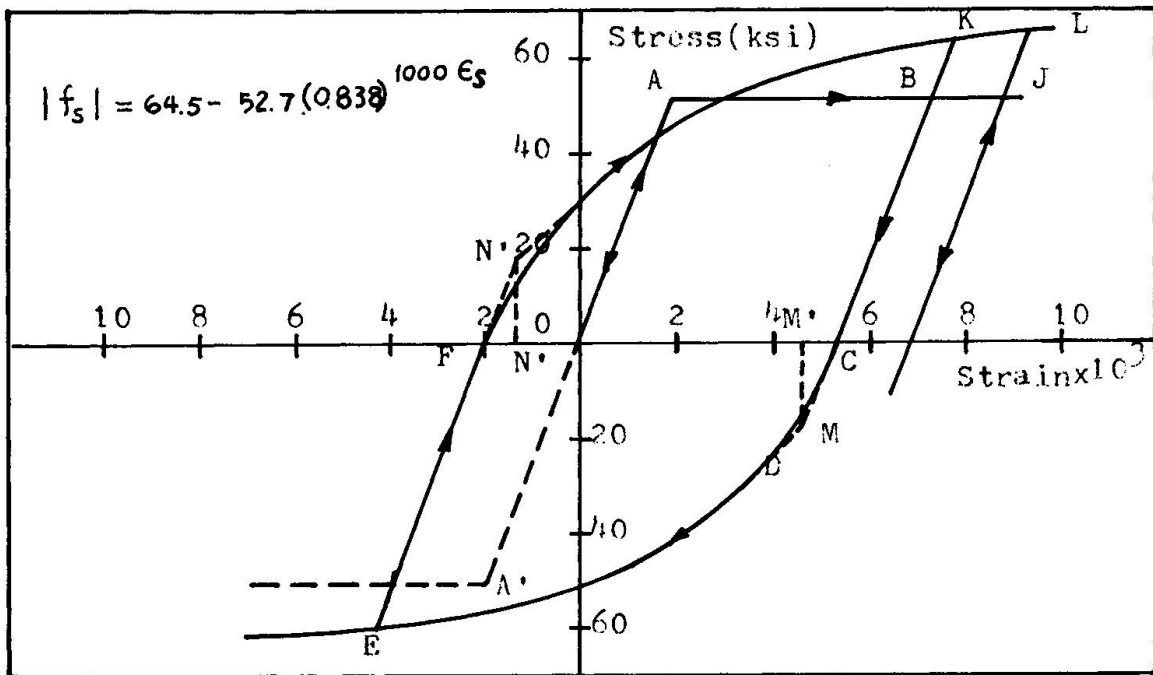

Figure 3 - Hysteresis Loops for Mild Steel

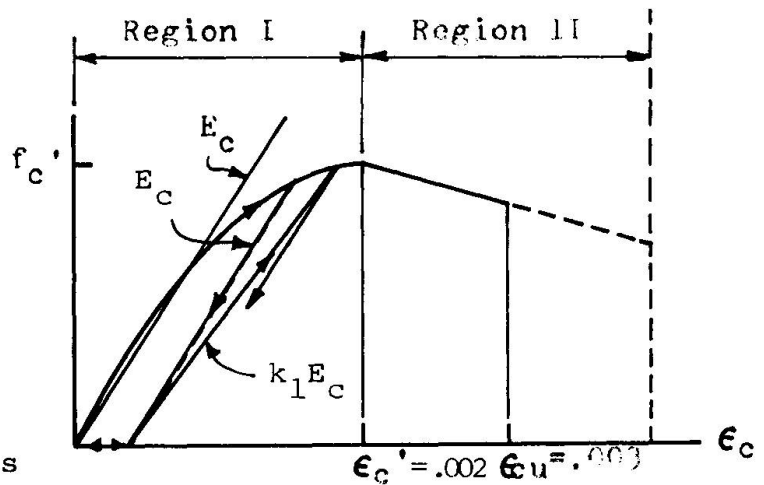
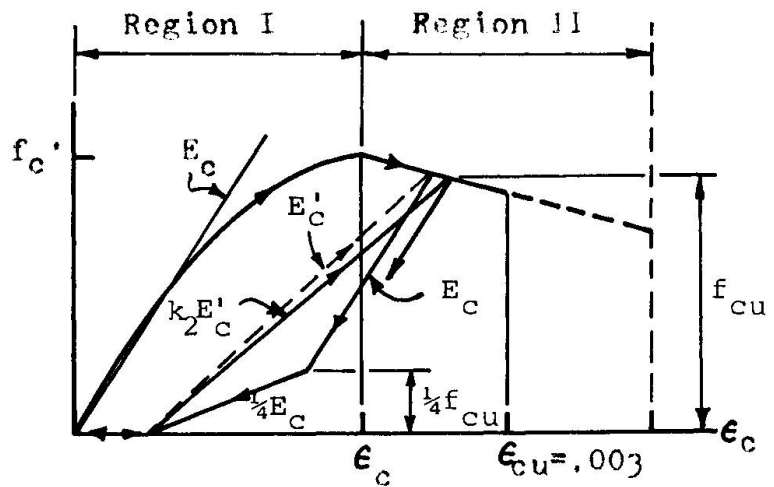

Figure 4 - Hysteresis Loops for Concrete



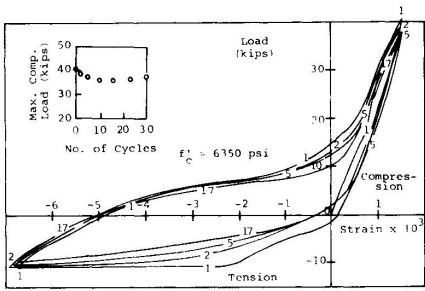

Figure 5a - Experimental Hysteresis Loops (Plain Bars-Controlled Strain)

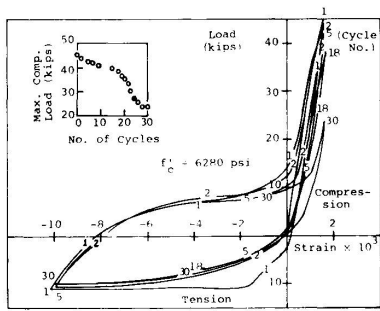

Figure 6a - Experimental Hysteresis Loops (Plain Bars-Controlled Strain)

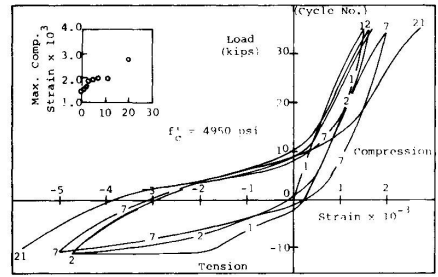

Figure 7a - Experimental Hysteresis Loops (Plain Bars-Controlled Load)

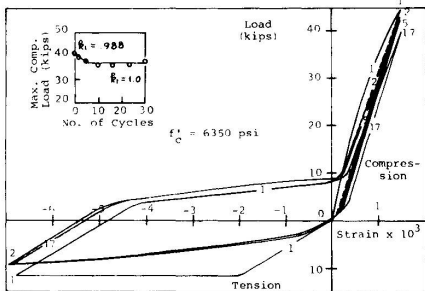

Figure 5b - Analytical Hysteresis Loops (Plain Bars-Controlled Strain)

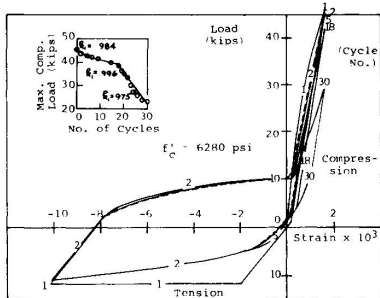

Figure 6b - Analytical Hysteresis Loops (Plain Bars-Controlled Strain)

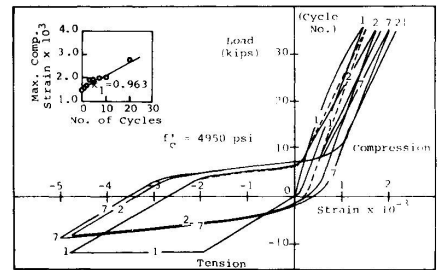

Figure 7b - Analytical Hysteresis Loops (Plain Bars-Controlled Load)

SUMMARY

This paper presents the results of tests made on longitudinal specimens of reinforced concrete subjected to reversed cyclic axial loading. These results are plotted as hysteresis loops giving the loads in kips versus the strain. Analytical hysteresis loops for the same element are also given in the paper and are compared with the experimental curves.

RESUME

Cette contribution montre les résultats d'essai sur éprouvettes longitudinales en béton armé sous l'effet de charges cycliques alternées. Les résultats sont reproduits par boucles d'hystérésis indiquant les charges en kilopound par rapport à la sollicitation. On montre également des boucles d'hystérésis analytiques pour le même élément et on les compare avec les courbes expérimentales.

ZUSAMMENFASSUNG

Der Beitrag vermittelt die Versuchsergebnisse an Längsprobekörpern aus Stahlbeton unter Einwirkung wechselnder zyklischer Belastung. Diese Resultate werden als Hysteresekurven aufgezeichnet, welche die Belastung in Kilopound, bezogen auf die Beanspruchung angeben. Ebenfalls werden analytische Hysteresekurven für dasselbe Element gegeben und mit den experimentellen Kurven verglichen.

IV

The Elasto-Plastic Response of Coupled Shear Walls under Cyclic Reversed Loading

Comportement élasto-plastique de parois de cisaillement sous charge cyclique alternée

Elasto-plastisches Verhalten von Schubwänden unter zyklischer Wechselbelastung

T. PAULAY

Reader in Civil Engineering
University of Canterbury
New Zealand

Shear walls provide one of the most effective means to resist lateral loads in earthquake resistant multistorey buildings. In the majority of cases it is neither possible nor economical to design shear walls so as to resist the seismic forces, generated during a very large earthquake, within the elastic range of behaviour. In the use of shear walls too reliance must be placed on energy absorption in the plastic range. Because of the geometry of such structures and the damage encountered in some nominally reinforced concrete shear walls some scepticism exists with regards ductility. It is for this reason that in a continuing research program various aspects of the seismic behaviour of shear walls is being studied at the University of Canterbury.

One recent project examined the behaviour of coupled shear walls under simulated cyclic loading. The critical members of such a structure, models of which are shown in Fig. 1, are the coupling beams. These are usually rather short and often relatively deep. With only a moderate flexural steel content high shearing forces can be generated when the yield capacity of the flexural reinforcement is being utilised. These shear forces, causing diagonal cracking over the whole extent of the coupling beams, dominate their behaviour. During reversed cyclic loading the diagonal cracks, formed in one direction, must close before diagonal compression, necessary for the effective working of stirrup shear reinforcement, can develop. This usually results in large displacements at low loads. Progressive yielding in the top and bottom flexural reinforcement leads to a relatively large continuous crack at the junction of the beams with the coupled walls. The high shear force cannot be transferred across this crack, where grinding of the concrete occurs. After only a few load cycles a sliding shear failure occurs. Only limited ductility can be achieved in such beams.^{1,2.}

Further studies showed that if, instead of the conventional flexural and shear reinforcement, only diagonal bars are used in coupling beams, the whole of the shear force can be effectively transferred from one wall to another one with very little assistance from the surrounding concrete. Stable hysteresis loops and large ductility were obtained for such coupling beams.^{2,3.} The diagonal bars are assembled in a cage with ample spiral binding or ties so that instability failure during compression loading does not occur.

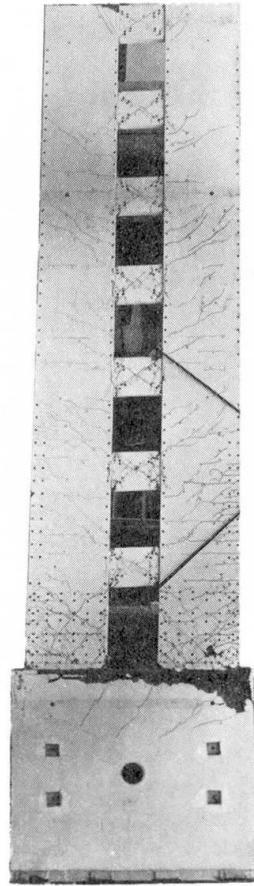
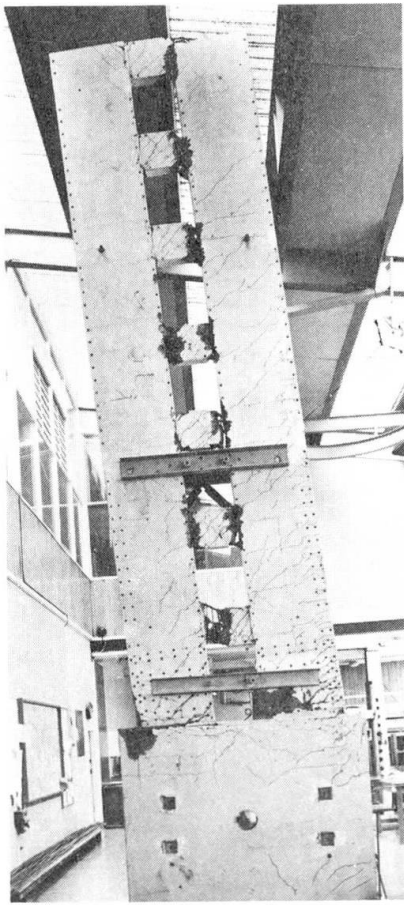

Fig. 1. One quarter full size reinforced concrete coupled shear wall models with conventional (on the left) and diagonal (on the right) reinforcement in the coupling beams.

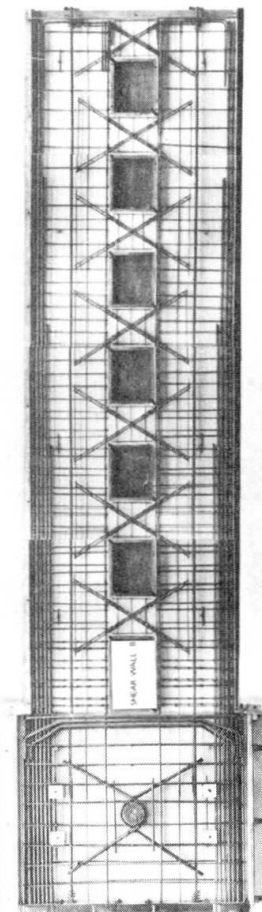
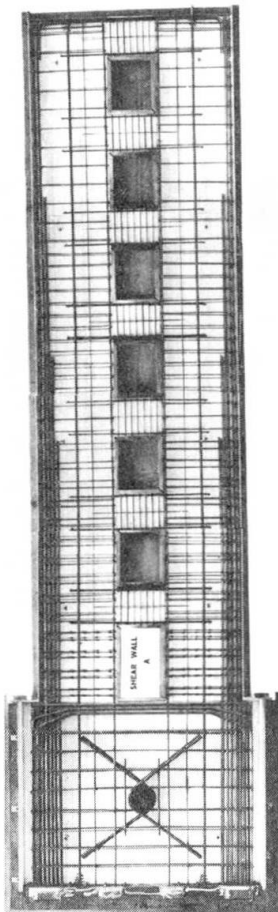

Fig. 2. The arrangement of the beam reinforcement in two otherwise identical coupled shear wall models.

In two one quarter full size seven storey reinforced concrete coupled shear wall models the various effects of the differently reinforced coupling beams upon overall behaviour were studied. The identical wall reinforcement for the two models with the different coupling beam steel are shown in Fig. 2. Lateral point loads of equal intensity were applied at the 3rd, 5th and 7th floors in alternate directions. Fig. 1 shows that, as expected, in Wall A all coupling beams failed by sliding shear. In spite of this considerable ductility was observed with only moderate loss of strength during progressive reversed loading into the plastic range. The damage appears to be much less in the case of Wall B shown in Fig. 1. The full capacity of the beams were maintained in this second test till the end, when the base of the wall failed.

The load-displacement (at the 7th floor) relationship for both specimens is presented in Fig. 3. This clearly shows the excellent hysteretic properties of the shear wall with diagonally reinforced coupling beams. The full strength of the structure could be attained four times in each direction when roof level displacement, corresponding with ductility factors of 4 to 12, were imposed.

The tests have shown that carefully designed and detailed coupled shear walls can possess all the qualities required to give the highest degree of protection against damage in moderate earthquakes and to ensure survival during catastrophic ground shaking. Walls with this type of reinforcing are now being constructed in New Zealand.

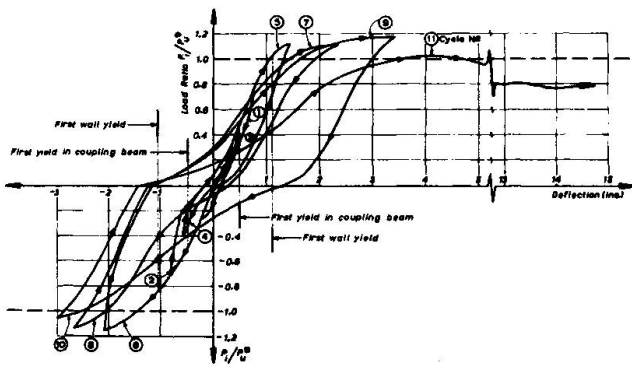
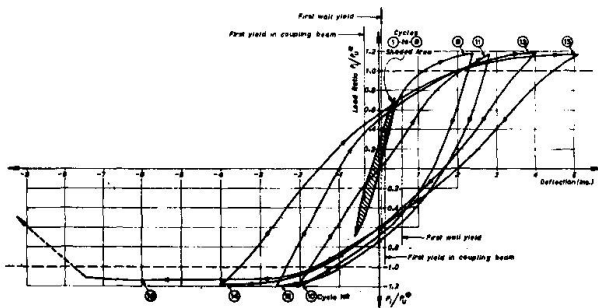

Fig. 3 Load - roof displacement relationship for walls with conventionally reinforced beams (above) and diagonally reinforced coupling beams (below) (P_i = applied load) (P_u = theoretical ultimate load)



References

1. Paulay, T., "Coupling Beams of Reinforced Concrete Shear Walls", Journal of the Structural Division, American Society of Civil Engineers, Vol. 97, No. ST3, March 1971, pp. 843-862.
2. Paulay, T., "Simulated Seismic Loading of Spandrel Beams", Journal of the Structural Division, American Society of Civil Engineers, to be published in September 1971.
3. Paulay, T., "Some Seismic Aspects of Coupled Shear Walls", Proceedings 5th World Conference of Earthquake Engineering, Rome, 1973, Vol. 2. Paper 245, p. 4.

Leere Seite
Blank page
Page vide

IV

Cyclic Load Tests on Concrete Frames

Essais de charge cyclique sur cadres en béton armé

Zyklische Belastungsversuche an Stahlbetonrahmen

R. PARK

Professor of Civil Engineering
University of Canterbury
New Zealand

1. INTRODUCTION

Tests on concrete frames subjected to cyclic (reversed) loading are at present being conducted at the University of Canterbury. Full scale beam-column assemblies with a range of proportions of prestressing steel and ordinary reinforcing steel are being tested to examine the behaviour of plastic hinge regions in members and joint cores. The tests are aimed at determining the deformation capacity and degree of damage of concrete frames when responding to severe earthquake motions and will provide information for design. The results from three beam-column assemblies, and a repaired assembly, subjected to static cyclic loading will be briefly described.

2. TESTS ON FULL SCALE BEAM-COLUMN UNITS

2.1 Test Specimens and Loading

The dimensions of the three test units are shown in Fig. 1. The test units represented approximately that part of a frame between points of contraflexure at a typical interior beam-column joint. The loading was as shown in Fig. 2 with an axial column load $P = 224$ kips (996 kN) and transverse loads on the ends of members representing the shear forces induced by earthquake loading.

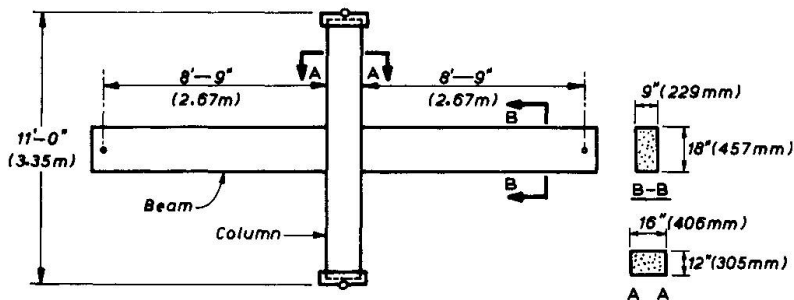

Fig. 1 Dimensions of Units 1, 2 and 3
(1" = 25.4 mm)

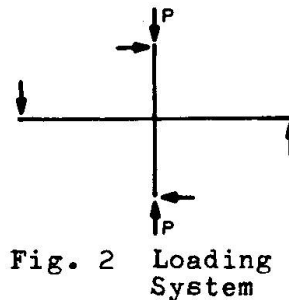

Fig. 2 Loading System

By reversing the directions of the transverse loads the effect of earthquake shaking was simulated. The transverse loading was such as to enforce deformations into the inelastic range several times. Plastic hinging was expected to occur in the beams because the flexural strength of the columns was greater than that of the beams. Fig. 3 shows a test unit at the start of testing.

Details of the cross sections of the columns and the beams are shown in Figs. 4 and 5. The beams of the test units contained various quantities of prestressed high tensile steel and non-prestressed mild steel deformed bar. Unit 1 had a fully prestressed beam, Unit 2 had a partially prestressed beam and Unit 3 had an ordinary reinforced beam. All beams had approximately the same theoretical ultimate flexural strength. The columns of all three test units were identical, containing non-prestressed high strength steel deformed bars in the longitudinal direction. The mild steel shear reinforcement in the members was designed according to the ACI building code¹. In the beams the stirrups were sufficient to carry all the shear force. In the columns some shear was assumed to be carried by the concrete. In the joint region $\frac{5}{8}$ in (16 mm) diameter hoops at 2 in (51 mm) centres were provided to carry the

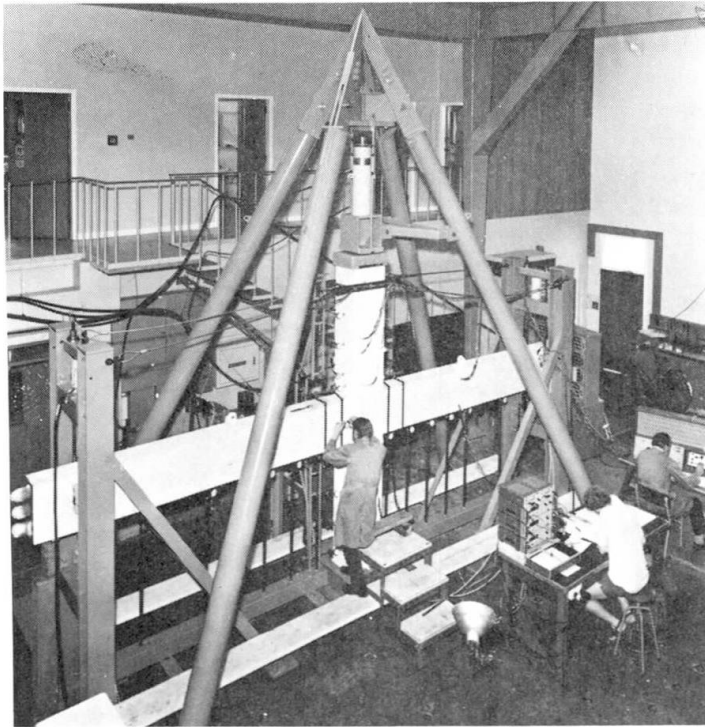

Fig. 3 Unit 1 in Test Frame at Start of Testing.

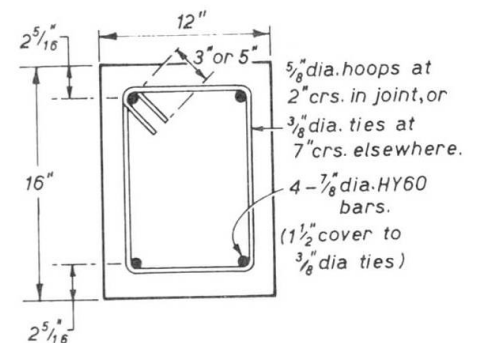

Fig. 4 Column Section of Units 1, 2 and 3 (1" = 25.4 mm).

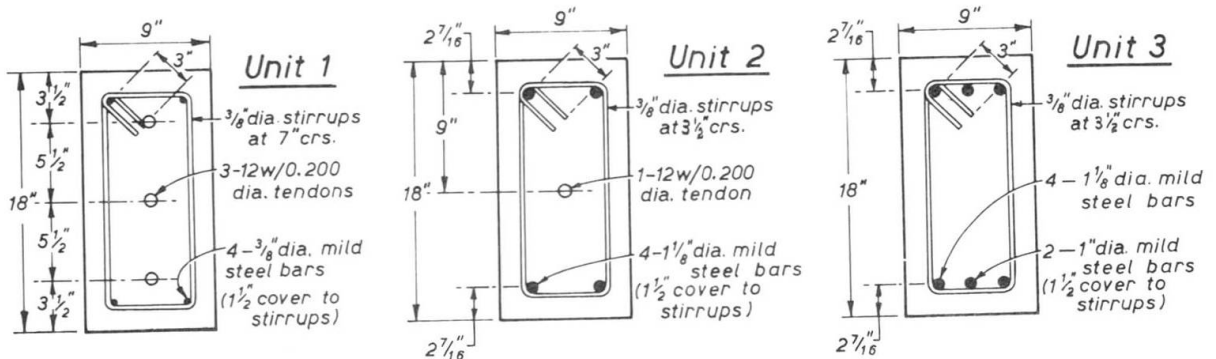

Fig. 5 Beam Sections (1" = 25.4 mm)

horizontal shear forces acting on the joint core due to the column shear and the tensile and compressive forces in the beams acting on each side of the joint core.

The concrete compressive cylinder strength for the members at the time of testing ranged between 4.63 ksi (31.9 N/mm²) and 5.51 ksi (38.0 N/mm²). The prestressing steel had an ultimate tensile strength of 236 ksi (1628 N/mm²). The prestressing tendons were post-tensioned to 70% of the ultimate tensile strength and grouted. The yield stresses of the reinforcing steel were 40.4 - 46.0 ksi (279 - 317 N/mm²) for the longitudinal beam steel, 58.8 - 60.2 ksi (406 - 415 N/mm²) for the longitudinal column steel and 41.9 - 43.5 ksi (289 - 300 N/mm²) for the transverse steel.

2.2 Test Results of Original Units

Figs. 6, 7 and 8 show for the units the vertical deflection at the ends of the beams plotted against the bending moment in the beams at the column face, and views of the test units showing the degree of damage sustained at two load stages.

In the three test units the maximum moments reached in the beams in the initial inelastic loading runs in each direction were within 9% of the theoretical flexural strengths of the beams calculated for an extreme fibre concrete compressive strain of 0.003 from first principles using the stress-strain curves for the steel and concrete, strain compatibility across the section and equilibrium of internal forces. With subsequent load cycles in the case of the prestressed concrete beam the inelastic deformation and damage concentrated in the beam and the joint core remained intact, whereas in the case of the partially prestressed and reinforced concrete beams the inelastic deformation and damage concentrated in the joint core and the adjacent members remained intact.

For Unit 1 (prestressed beam) the decrease in the strength and stiffness of the beam with further cyclic loading was due to the reduction of the beam cross-section caused by crushing of the concrete. This pointed to the need for more confinement of the concrete by transverse steel at closer spacing. The energy dissipation of the prestressed member was small until concrete crushing had commenced. In this unit the inelastic deformations were mainly due to the plastic hinge rotation in the beams, as is evident from the views of the tested unit shown in Fig. 6.

For Unit 2 (partially prestressed beam) and Unit 3 (ordinary reinforced beam) the failure concentrated in the joint core. The attainment of the flexural strength of the beams of both of these units was accompanied by severe diagonal tension cracking in the region of the joint core, particularly in the case of Unit 3, as is evident from the views of the tested units shown in Figs. 7 and 8. With further loading cycles the maximum beam moment reduced owing to a reduction in the shear strength of the joint cores of these units and the deflection at the end of the beams became mainly due to shear deformations of the joint core. In these two units the longitudinal reinforcement in the beams also showed some tendency to slip backwards and forwards through the joint core due to breakdown of bond, causing a reduction in stiffness of the units.

Comparison of the moment-deflection curves of Figs. 6, 7 and 8 indicates that even after large inelastic deflections the prestressed concrete beam had great ability to recover deflections. Nevertheless the energy dissipated by the prestressed concrete unit (as represented by the area within the hysteresis loops) was quite large after crushing of concrete had commenced. The energy dissipated by the partially prestressed and ordinary reinforced units was larger due to the presence of ordinary steel reinforcement.

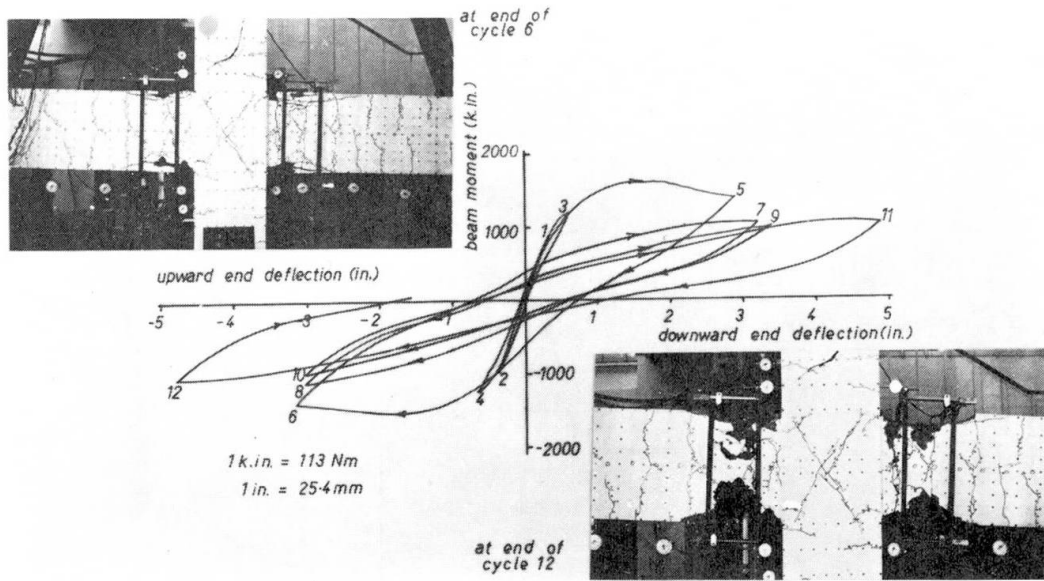

Fig. 6 Unit 1 Beam Moment at Column Face versus Beam End Deflection

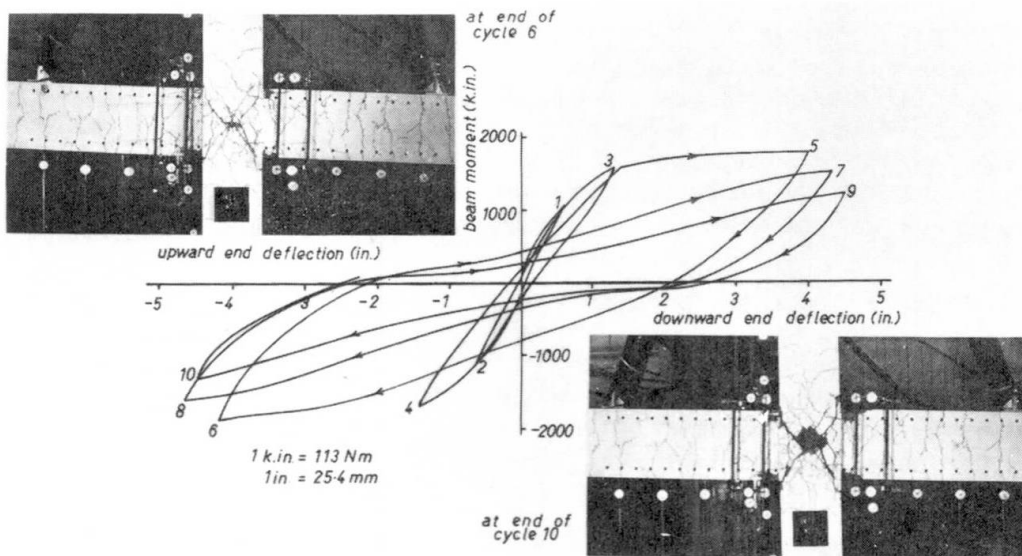

Fig. 7 Unit 2 Beam Moment at Column Face versus Beam End Deflection

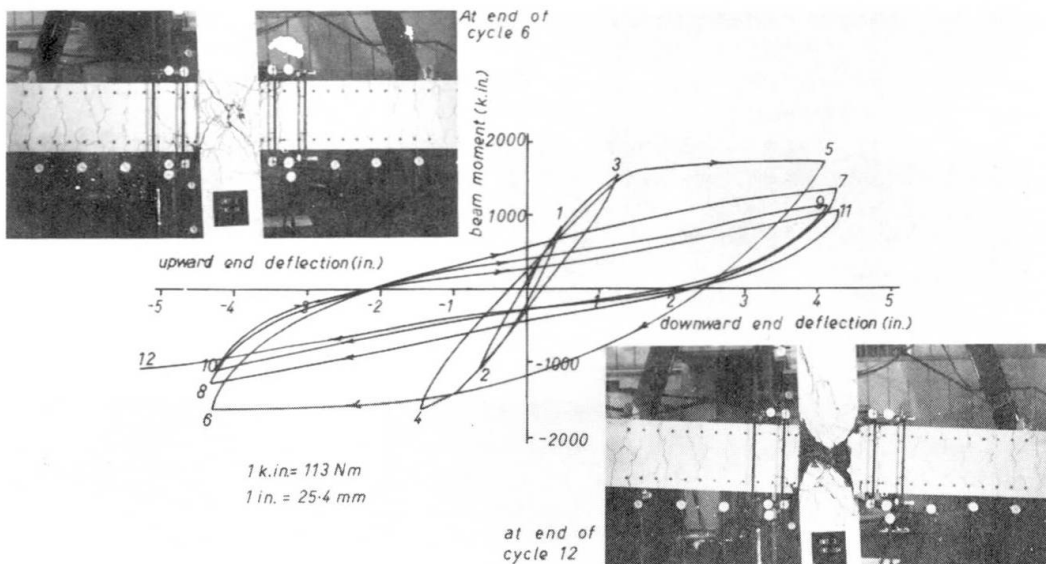

Fig. 8 Unit 3 Beam Moment at Column Face versus Beam End Deflection

2.3 Test Results of Repaired Unit 1

After the testing of Unit 1 it was decided to repair the damaged concrete and to retest the unit to investigate whether satisfactory structural behaviour could be achieved. The damaged beam was repaired by straightening the beam, chipping away the damaged concrete, placing two new stirrups around the remaining core of the beam in each damaged region and casting new concrete to give the original cross-sectional dimensions. Fig. 9 shows the new concrete placed at one beam region and the other region ready for the mould to be placed around for the new concrete. The new concrete had a maximum aggregate size of $\frac{3}{8}$ in (9.5 mm) and at the time of testing the unit had a compressive cylinder strength of 7.40 ksi (51.0 N/mm²).

The repaired Unit 1 was subjected to similar load cycles as the original unit. Fig. 10 shows the vertical deflection at the end of the beam plotted against the bending moment in the beam at the column face, and the damage sustained at two load stages. Comparison with Fig. 6 shows that the initial stiffness of the repaired unit was less than that of the original unit. This would have been due to the early cracking of the new concrete and the presence of cracks in regions of the original concrete. It is to be noted that the new beam concrete was not prestressed, the tendons merely acting as ordinary reinforcement in that concrete. The crack control in the new concrete was not as good as in

the original unit but the cracking was not excessive. For example, at 63% of the measured ultimate moment the maximum crack width in the new concrete was 0.015 in (0.38 mm) whereas in the original prestressed beam that crack width was not reached until 98% of the measured ultimate moment had been applied. The maximum measured bending moments reached in the beams in the repaired unit in the initial inelastic loading runs in each direction were within 14% of the maximum measured bending moments of the original unit. The joint core remained undamaged apart from small diagonal tension cracks.

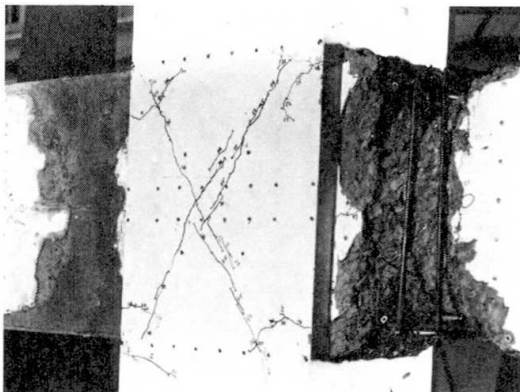

Fig. 9 Repair of Unit 1

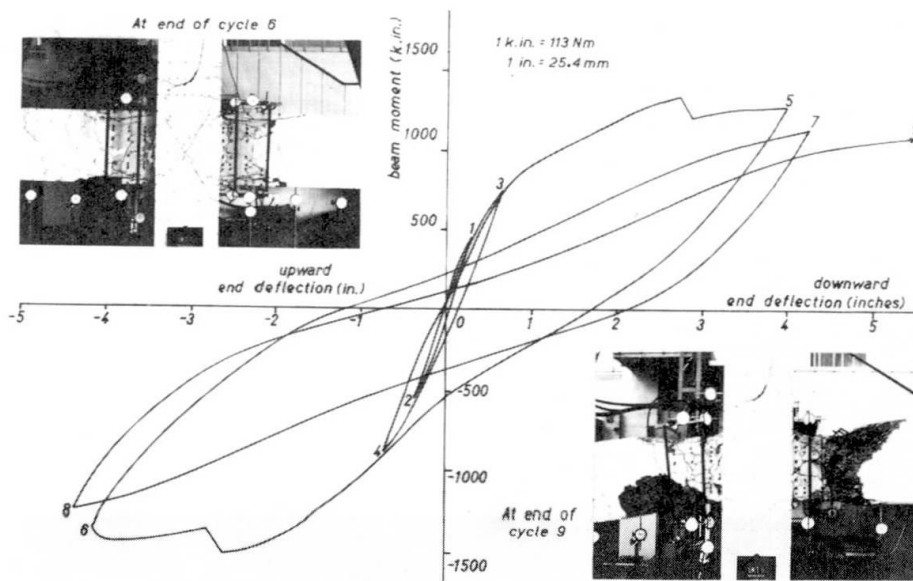

Fig. 10 Repaired Unit 1 Beam Moment at Column Face versus Bend End Deflection

3. CONCLUSIONS

The main findings from the tests are:

- (a) Beams: In order to obtain ductile behaviour of prestressed concrete beams under intense inelastic reversed loading, adequate confinement of concrete should be provided by transverse steel in plastic hinge regions to prevent excessive loss of section when crushing of concrete commences. The exact amount of transverse steel necessary requires further investigation but tentatively it appears that a stirrup spacing of 4 in (100 mm) should not be exceeded in these regions, and closer spacing may be necessary. The partially prestressed and ordinary reinforced beams showed good ductile behaviour mainly due to the presence of compression reinforcement. However the compression reinforcement showed a tendency to slip through the joint core, due to breakdown of bond, thus reducing its effectiveness.
- (b) Columns: In these tests the columns were stronger than the beams and hence were not critical elements, apart from the joint core regions.
- (c) Joint Cores: The joint was not critical in the assembly with the prestressed beam. However in the assemblies with the partially prestressed beam and the ordinary reinforced beam a shear failure occurred in the joint core in spite of shear reinforcement being placed there according to the design procedure of ACI 318-71¹. In the prestressed concrete beam the compressive concrete force was higher and this evidently helped the joint core behaviour, along with the presence of the central prestressing tendon. Aspects of joint core behaviour are not fully understood and require much further investigation.
- (d) Energy Dissipation: All units showed considerable energy dissipation once the maximum moment capacities had been reached. The ordinary reinforced assembly showed greater energy dissipation than the assembly with the partially prestressed beam which in turn showed greater energy dissipation than the assembly with the prestressed concrete beam. However comparisons are difficult because for the assembly with the prestressed beam the inelastic deformation came mainly from the beam plastic hinges whereas for the other assemblies the inelastic deformation eventually came mainly from the shear deformations of the joint cores.
- (e) Repair: Repairs made to the prestressed beam by replacing the damaged concrete, and the retesting, showed that it was possible to repair badly damaged members. Repairs to the assemblies with damaged joint cores would have been much more difficult however.

Acknowledgements

The tests reported were carried out by graduate student K.J. Thompson and technicians A.G. Foot and J.M. Adams under the supervision of the author.

References

1. ACI Committee 318, "Building Code Requirements for Reinforced Concrete (ACI 318-71)", American Concrete Institute, Detroit, Michigan, 1971, pp. 78.

SUMMARY

Tests on concrete frames subjected to static cyclic loading simulating the effect of earthquake shaking are described. The test frames were full-scale interior beam-column assemblies with a range of proportions of prestressing steel and ordinary reinforcing steel. The tests are part of a continuing series aimed at determining the deformation capacity and degree of damage of concrete frames when responding to severe seismic load reversals. The results from three test frames are given, including the behaviour of a frame retested after repairing damage. The importance of traverse steel for confinement of compressed concrete in members, and for shear reinforcement in joint cores, is emphasized.

RESUME

On décrit des essais effectués sur cadres en béton armé soumis à une charge cyclique statique due à l'effet de secousses aux tremblements de terre. Les cadres d'essai étaient composés de poutres et colonnes à l'échelle, en acier précontraint et en acier d'armature habituel. Les essais font partie d'une série pour la détermination du degré de déformation et des dégâts aux cadres en béton armé soumis à des secousses alternées. On montre les résultats obtenus sur trois cadres d'essai y compris le comportement d'un cadre aux essais exécutés après l'élimination des dégâts. L'importance de renforts transversaux servant à limiter le béton comprimé dans les membres et de renforts de cisaillement dans les noyaux est soulignée.

ZUSAMMENFASSUNG

Es werden Versuche an Stahlbetonrahmen beschrieben, die einer statischen zyklischen Belastung hinsichtlich der Wirkung von Erdbebenerschütterungen ausgesetzt sind. Die Testrahmen waren massstäbliche innen zusammengebaute Balken und Stützen mit proportionalen Anteilen an vorgespanntem und gewöhnlichem Armierungsstahl. Die Versuche sind Teile einer fortlaufenden Reihe zur Bestimmung der Grösse der Deformation und der Höhe der Schäden an Stahlbetonrahmen, wenn diese stark wechselnder Erdbebenbelastung unterworfen sind. Es werden die Resultate an drei Versuchsrahmen, einschliesslich des Verhaltens eines Rahmens bei nachträglich vorgenommenem Versuch nach Behebung des Schadens mitgeteilt. Die Wichtigkeit von Querstreben zur Begrenzung komprimierten Betons in Baugliedern und von Schubbewegungen in Kernen wird hervorgehoben.

Leere Seite
Blank page
Page vide

IV

Effect of Grouting on the Fatigue Strength of Post-Tensioned Concrete Beams

Influence de l'injection des câbles sur la résistance à la fatigue des structures en béton précontraint

Einfluss des Einpressmörtels auf die Ermüdungsfestigkeit von Spannbetonkonstruktionen

Troels BRØNDUM-NIELSEN
Professor, Dr. techn.
Structural Research Laboratory
Technical University of Denmark

In the Structural Research Laboratory at the Technical University of Denmark tests have been carried out in order to investigate

The fatigue strength of prestressing wire.

The fatigue strength of anchorages for prestressing wire and tendons.

The influence of bond on the fatigue strength of post-tensioned concrete beams.

The research project was carried out under the supervision of S. Gravesen and E. Skettrup. N. J. Jørgensen and F. Petersen assisted in the beam tests.

For most prestressing systems the fatigue strength of the anchorages is much lower than the fatigue strength of the tendons. However, it should nevertheless be possible to utilize the fatigue strength of the tendons provided that the following three conditions are fulfilled:

The anchorages should be placed in zones where the stress variations are small, for instance, in the vicinity of simple supports.

The ducts for the tendons should be grouted after the tensioning.

The grout should be able to transfer stresses of a magnitude which is sufficient to ensure a reliable bond between tendon and concrete.

The test results have not yet been published. A brief description will be given in the following.

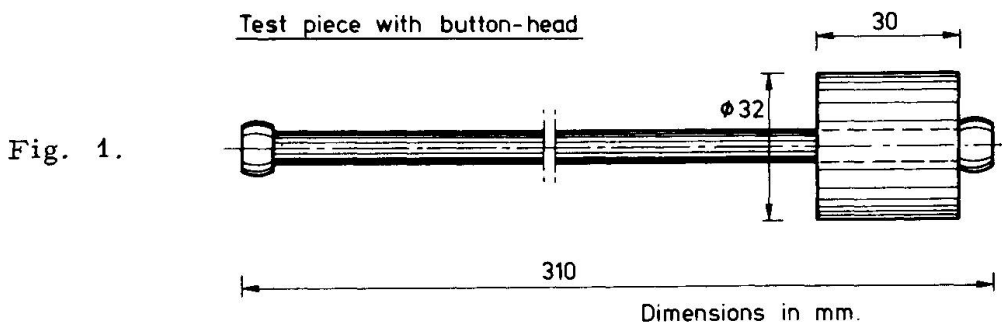

One prestressing system tested in our laboratory used button heads on the wires (see Fig. 1). These heads were made by pressing the ends

of the wires so that the diameter was locally increased. When the wire is threaded through holes in the anchor plates the button head will anchor the wire to the plate (see Fig. 2).

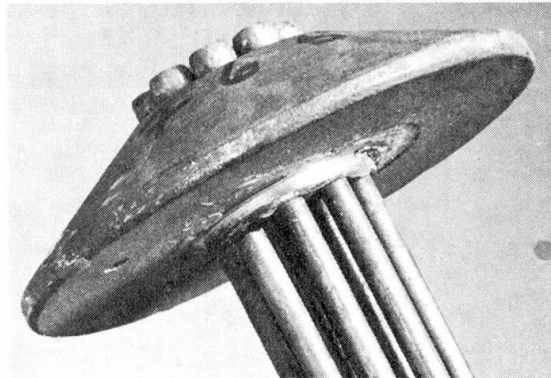

Fig. 2.

A stress-strain curve for the wire is shown in Fig. 3.

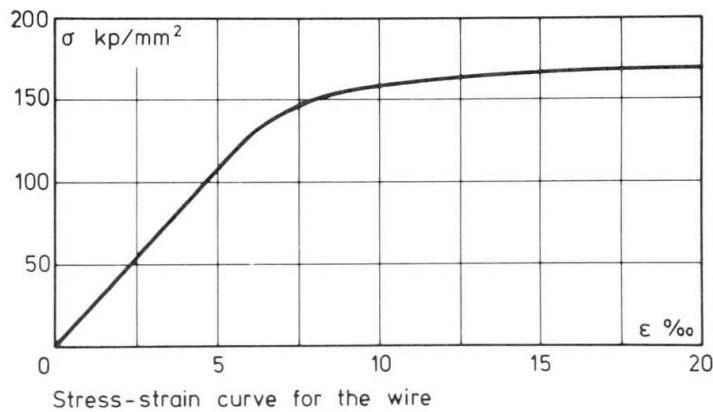

Fig. 3.

The fatigue strength of the wire proper is illustrated by the Wöhler diagram in Fig. 4.

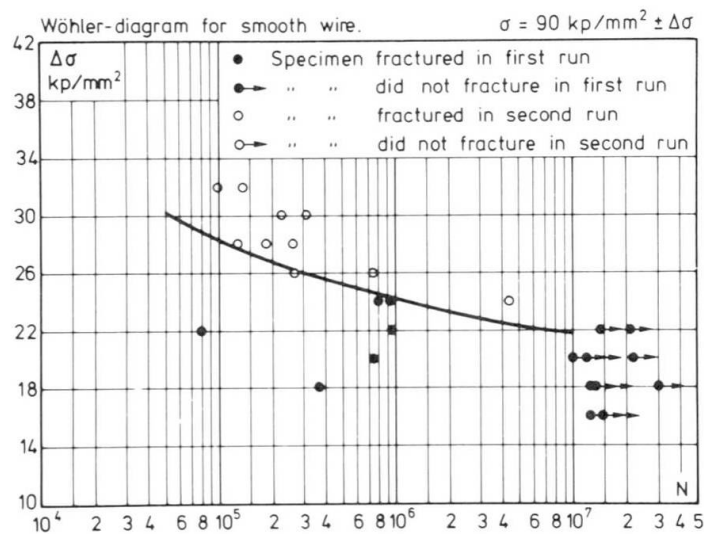
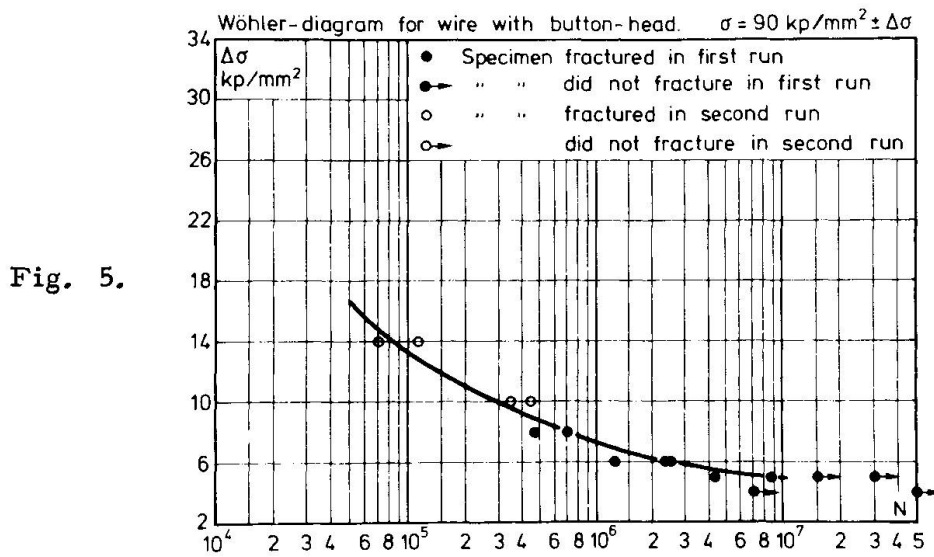
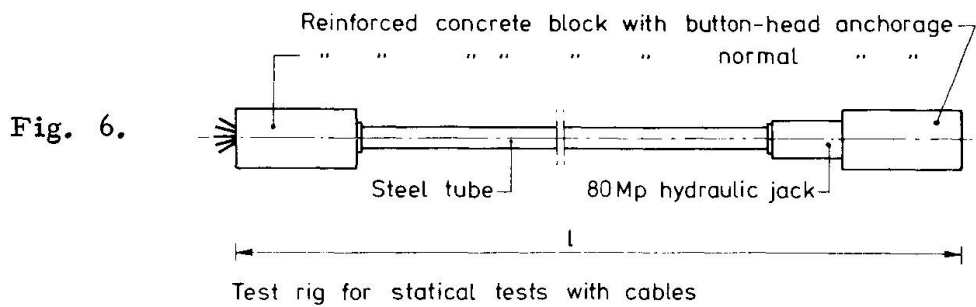

Fig. 4.

The corresponding diagram for wire anchored with button heads is illustrated in Fig. 5.



Static tensile tests were carried out with cables (see Fig. 6). The results of these tests are illustrated in Table 1.



Test No.	Location of rupture	Character	Cable force Mp	Cable stress kp/mm^2
1	active anchorage	inclined	68	147
2	-	-	68	147
3	-	-	66	143
4	-	-	72	156
5	-	-	64	139
6	-	-	64	139
7	-	necking	78	169
8	passive anchorage	necking at button-head	76	165
9	active anchorage	necking	79	171

Table 1.

The fatigue strength of the cables were measured in the test rig illustrated in Fig. 7 and the results of the tests are given in Table 2.

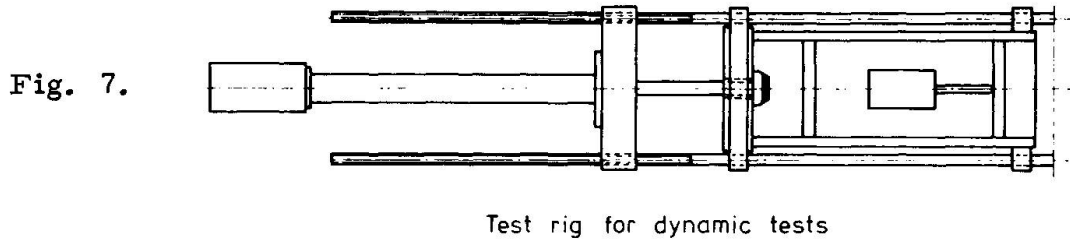

Test No.	Stress and force level		Number of load cycles in millions	
	kp/mm ²	Mp		
1	90 ± 4	41.6 ± 1.85	0.829	First wire fracture Second - fracture
	90 ± 4	38.1 ± 1.70	0.986	
2	90 ± 4	41.6 ± 1.85	1.719	Fracture in two wires
3	90 ± 4	41.6 ± 1.85	0.828	First wire fracture Second - fracture No further fractures
	90 ± 4	38.1 ± 1.70	0.944	
	90 ± 4	34.6 ± 1.55	3.866	

Table 2.

Fatigue tests were carried out with 6 post-tensioned concrete beams (see Fig. 8). In order to simulate severe bond stress conditions, a shear span to depth ratio of about 3.0 was adopted.

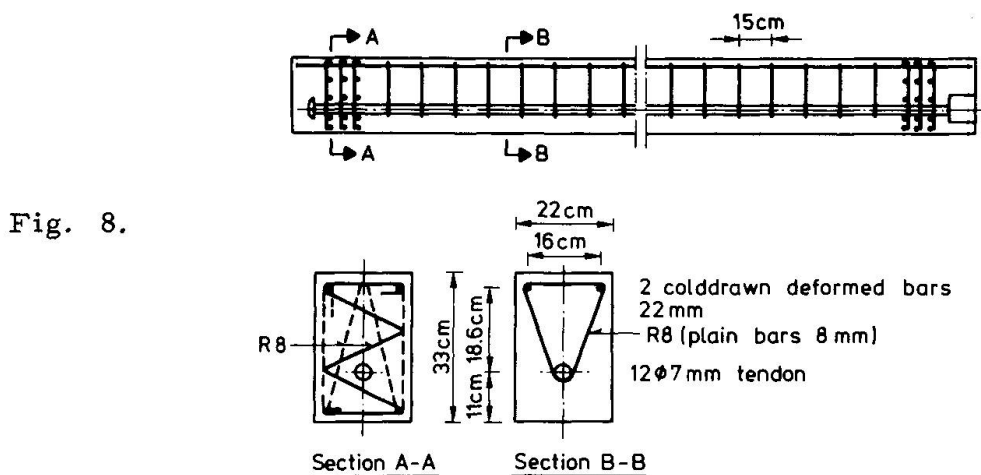

In three of the beams the cable duct was grouted whereas the duct was left ungrouted in the remaining three. The beams were subjected to a fatigue load in bending (see Fig. 9).

First a stress amplitude in the tendons of 5.5 kp/mm² in the un-

grouted beams and 6 kp/mm^2 in the grouted beams was adopted. All six beams were subjected to about 2 million load cycles of this magnitude without rupture.

Fig. 9.

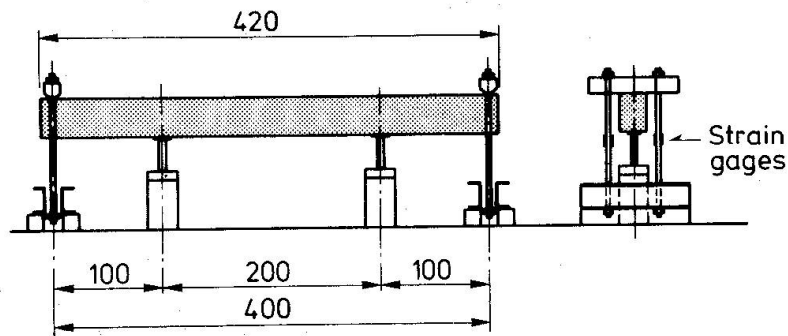

Afterwards the stress amplitude was increased to $7,6 \text{ kp/mm}^2$ in the ungrouted tendons and $7,8 \text{ kp/mm}^2$ in the grouted tendons, and the beams were subjected to this load until rupture. The number of cycles before rupture is indicated in Table 3.

Beam No.	Grouted			Ungouted		
	1	3	5	2	4	6
Number of load cycles before rupture in millions	2.02	3.18	2.09	0.26	0.23	0.09

Table 3.

Conclusion.

According to the test results, the fatigue strength of post-tensioned concrete structures with unbonded tendons is low due to the low fatigue strength of the anchorages. If the anchorages are located in zones where the stress variations are small, the fatigue strength of the structure can be increased considerably by grouting the ducts.

SUMMARY

The fatigue strength of post-tensioned concrete structures with unbonded tendons is low due to the low fatigue strength of the anchorages. Tests carried out at the Technical University of Denmark indicate that the fatigue strength can be increased considerably by grouting the ducts, provided that the anchorages are located in zones where the stress variations are small.

RESUME

La résistance à la fatigue des structures en béton précontraint, utilisant des câbles gainés non injectés, est faible, due à la modeste résistance à la fatigue des ancrages. Des essais réalisés à l'Université Technique du Danemark montrent que cette résistance à la fatigue peut être augmentée considérablement par l'injection des câbles, pourvu que les ancrages soient placés dans des zones à faible variation de contrainte dans le béton.

ZUSAMMENFASSUNG

Die Ermüdungsfestigkeit von Spannbeton ohne Verbund ist niedrig, weil die Ermüdungsfestigkeit der Verankerungen niedrig ist. Versuche an der Technischen Hochschule Dänemarks zeigen, dass die Ermüdungsfestigkeit durch Auspressen der Spannkanäle mit Zementmörtel vergrößert wird, vorausgesetzt dass die Verankerungen in Zonen mit niedrigen Betonspannungsvariationen angebracht sind.

IV

Summary Report on Theme IV

Rapport sommaire au thème IV

Zusammenfassender Bericht zum Thema IV

R. PARK*

Professor of Civil Engineering
University of Canterbury
New Zealand

1. Comments on the Prepared Discussions

Seven contributions were made to the prepared discussion of this Theme.

Ohno, Shibata and Hattori present a review of the results of shear tests conducted on 378 reinforced concrete column specimens conducted in Japan since 1961. The tests allow an assessment of the shear strength and ultimate lateral deformability at the shear failure of columns with both monotonic and repeated reversed loading. A shear strength equation is obtained from the experimental data which shows the shear strength as a function of the axial load, shear span/depth ratio, size of specimen, concrete compressive strength, web and axial reinforcement contents and the yield stress of the steel. No noticeable difference between the strength under monotonic or repeated reversed loading is found. Equations for ultimate deformation due to shear are also given. The apparent absence of the effect of reversed loading on strength and deformability is a surprising result which may have been due to experimental scatter. This aspect requires further investigation.

Celebi and Penzien present test results from beams with column stubs tested under reversed loading and show that a marked pinching of the load-deflection loops occurs when the shear force is high, leading to a deterioration of stiffness due to shear. In their test beams when the nominal shear stress $V/bd = 3.75/f'$ psi the pinching is very significant but at lower nominal shear stress^c the effect of shear is not noticeable. Thus it is important to include the possible influence of shear in models for reversed load-deflection behaviour and these test results are of assistance for such modelling. A comparison of dynamic and static loading results from their tests also shows an increase in the initial yield for dynamic loading but no significant difference between subsequent static and dynamic load-deflection loops. This is a welcome result because it does mean that load-deflection

(* In the absence of Prof. V.V. Bertero who was unable to attend the Lisbon symposium due to illness)

loops obtained from static loading tests can be used with more confidence in dynamic loading situations.

Morita and Kaku produce experimental evidence for the local bond stress-slip relationship under repeated loading found from tests on short concrete elements. Empirical equations are given which fit their test results well. The results are a useful addition to available information on the deterioration of bond with repeated loading.

White and Chowdhury present results from tests performed on 1/10 scale reinforced concrete beam-column assemblies which show very good load-deflection and moment-rotation agreement with prototype tests conducted by the Portland Cement Association. They also present results obtained from 1/10 scale three storey two bay reinforced concrete frames subjected to vertical loads plus reversing horizontal loads. The monotonic load-deflection curve was the envelope for the cyclic loading curves. The paper concludes that well detailed frames do not deteriorate significantly under severe cyclic loading and that small scale models may be used to investigate reversing load phenomena in reinforced concrete. The importance of meeting model material similitude requirements, for example concrete tensile strength, as closely as possible is emphasized. A point of interest is that the stiffness of the model frame under reversed lateral loading reduced very considerably (for example, to about $\frac{1}{3}$ of the initial stiffness), presumably due to softening of plastic hinges and bond deterioration. Such stiffness degradation will have a considerable effect on the response of a structure to dynamic motions.

Yamada, Kawamura and Kondoh report results from cyclic load tests conducted on reinforced concrete rectangular frames in which plastic hinging formed in either the beams or the columns. The theoretical load-deflection behaviour is computed using idealized stress-strain curves for the steel and concrete and reasonable agreement with the test results obtained. The effect of vertical load level on behaviour, particularly the softening of stiffness, is illustrated.

Tichý and Urban present experimental evidence which tends to show that for prestressed concrete beams which fail in compression, where an increase in the steel stress is possible, repeated loading may cause an increase in the load carrying capacity. They postulate that this is due to repeated loading causing a separation of the tension and compression zone of the member due to cracking and that the deformation of the concrete then becomes no longer dependent on the deformation of the steel. Thus a greater concrete force may be available and result in an increase in the ultimate moment capacity. However, on average the percentage increase is small, generally much less than 10%.

Muguruma, Tominaga, Takaya and Tada present test results for the flexural behaviour of prestressed concrete beams under repeated reversed loading. An idealized moment-curvature curve for prestressed concrete flexural members is proposed which takes into account deterioration of strength and stiffness with loading cycles. Compression steel and stirrups are shown to improve the ductility. This paper gives useful information regarding the shape of moment-curvature hysteresis loops for a number of variables which could be used in realistic dynamic analyses of prestressed concrete structures.

2. Concluding Remarks

2.1 Experimental Studies

Professor Bertero's comprehensive introductory report has been complemented by the contributions to the prepared discussion. Some general conclusions which may be drawn are as follows.

Reinforced Concrete

For reinforced concrete members (elements) when flexure dominates (low shear), properly detailed members can develop very high inelastic deformations. The flexural stiffness reduces with each cycle of loading but the maximum moment capacity does not reduce unless crushing of the concrete causes a reduction in the concrete cross section. Final failure may be due to buckling of compression steel. When flexure occurs with a high shear force, say a nominal shear stress V/bd greater than $\frac{3}{4}f'_c$ psi, an additional reduction in stiffness may occur in each cycle of loading due to shear, and failure may be initiated by shear. Web reinforcement should be provided to carry the greater part of the shear force. When flexure occurs with high shear and high axial compressive force, the reduction in the strength and stiffness with each cycle of loading may be substantial unless the column contains adequate transverse steel for shear reinforcement and concrete confinement. Hence there may be a substantial reduction in ductility unless columns contain closely spaced steel hoops.

A better indication of the behaviour of reinforced concrete members in frames may be obtained by testing beam-column assemblies. When lateral loading is applied to a frame substantial shear and bond forces need to be carried across the panel zones of beam-column joints. For example, a beam reinforcement bar passing through a column will be in compression on one side of the joint core and in tension on the other side, and hence twice the yield force of the bar may need to be developed by bond in the panel zone. Also, the horizontal shear force to be carried by the panel zone is twice the tensile force in the beam. Tests have shown that shear reinforcement is required in the panel zone of joints to prevent failure under cyclic load conditions which simulate reversed lateral loading on structures. If the beams frame into the columns on all four sides, the panel zone may be well confined by the surrounding beams and the problem may not be so serious. However if a single beam frames into only one or two sides of a column it may be difficult to prevent a shear failure occurring in the panel zone even with large quantities of shear reinforcement present. This is due to alternating diagonal tension cracks, which open and close in the panel zone as the direction of loading alternates. These cracks may eventually cause the concrete in the panel zone to break up, leading to a loss of strength and stiffness of the joint core.

Shear walls provide an effective way of carrying lateral forces in buildings and because of their greater stiffness they generally provide superior protection against damage. It is a wide spread belief that shear walls are brittle. Recent studies show however, that properly detailed shear walls can be ductile enough to sustain large lateral loads repeatedly while undergoing plastic deformations comparable with those expected in framed buildings.

Prestressed Concrete

Tests have shown that large post-elastic deformations can be obtained from prestressed concrete flexural members providing steel contents are not excessive. Energy dissipation prior to crushing of the concrete is small but is substantial once crushing of concrete has occurred. A reduction in stiffness occurs with high intensity cyclic loading. Mortar joints between precast post-tensioned frame members can behave satisfactorily under high intensity load reversals.

2.2 Future Research

Areas where future cyclic loading experimental research is still required involve the buckling of compressed reinforcing steel, shear-axial load-flexure interaction, beam-column and slab-column joints, shear walls, rate of strain effects, repair of members after damage, and the behaviour of complete structures.

Also, the full theoretical moment-curvature curve may require too much computer time for practical frame analysis and simple idealized curves may be adequate for use in the non-linear dynamic analysis of structures responding to earthquake motions or to wind. Simple idealizations already exist, for example, Clough's degrading stiffness model for reinforced concrete. More research is required to determine more accurate idealized moment-curvature loops and idealized deformation characteristics due to bond slip in plastic hinge regions and due to shear at plastic hinge regions and in panel zones of joints. This has already been discussed with regard to Theme I.

Experimental studies of reinforced subassemblages should also give an indication of the ductility requirements at critical plastic hinge regions in order to achieve the deflections required when structures respond non-linearly to earthquake motions, so that designers can detail sections for adequate rotation ductility. It is to be noted that the displacement response of a structure to a severe earthquake will depend on the shape of the load-displacement loops and hence, for example, prestressed and reinforced concrete structures will have different ductility demands.

In general the loading direction of earthquakes will cause biaxial bending and shear of columns and joint cores because the loading will seldom act in the direction of a principal axis of a building. Thus the shear strength of diagonally loaded columns and joint cores should also be considered. At present there is very little experimental evidence of the shear strength of members with diagonal loading.

The question of the repair of structures is a very important issue. More research is needed to determine whether badly damaged members can be repaired satisfactorily. Cracked members can be repaired by injecting epoxy resins into cracks as has been found at Berkeley University, and some badly crushed members have been repaired by replacing the damaged concrete by new concrete at the University of Canterbury. However more tests will be necessary before such repairs can be recommended with confidence.

Finally it is important that future testing should be carried out on realistic specimens involving subassemblages of beams, slabs, columns and walls where necessary to include all interaction effects.

SUMMARY

The contributions to the prepared discussion of Theme IV: Experimental Studies Concerning Reinforced, Prestressed and Partially Prestressed Concrete Structures and their Elements are commented upon briefly. Concluding remarks on experimental studies are made and areas requiring further research are indicated.

RESUME

Les contributions à la discussion préparée concernant thème IV sont brièvement commentées. On donne des remarques de conclusion sur des études expérimentales et on mentionne les domaines où des recherches ultérieures sont indiquées.

ZUSAMMENFASSUNG

Die Beiträge zur vorbereiteten Diskussion betreffend Thema IV werden kurz kommentiert. Es werden Schlussbemerkungen über experimentelle Studien angebracht und Gebiete bezeichnet, die weiterer Forschung bedürfen.

Leere Seite
Blank page
Page vide