

Zeitschrift: IABSE reports of the working commissions = Rapports des commissions de travail AIPC = IVBH Berichte der Arbeitskommissionen

Band: 34 (1981)

Artikel: Structural concrete as a plastic material

Autor: Braestrup, M.W.

DOI: <https://doi.org/10.5169/seals-26876>

Nutzungsbedingungen

Die ETH-Bibliothek ist die Anbieterin der digitalisierten Zeitschriften. Sie besitzt keine Urheberrechte an den Zeitschriften und ist nicht verantwortlich für deren Inhalte. Die Rechte liegen in der Regel bei den Herausgebern beziehungsweise den externen Rechteinhabern. [Siehe Rechtliche Hinweise.](#)

Conditions d'utilisation

L'ETH Library est le fournisseur des revues numérisées. Elle ne détient aucun droit d'auteur sur les revues et n'est pas responsable de leur contenu. En règle générale, les droits sont détenus par les éditeurs ou les détenteurs de droits externes. [Voir Informations légales.](#)

Terms of use

The ETH Library is the provider of the digitised journals. It does not own any copyrights to the journals and is not responsible for their content. The rights usually lie with the publishers or the external rights holders. [See Legal notice.](#)

Download PDF: 13.10.2024

ETH-Bibliothek Zürich, E-Periodica, <https://www.e-periodica.ch>



Structural Concrete as a Plastic Material

Béton armé comme matériau plastique

Stahlbeton als plastisches Material

M.W. BRAESTRUP

Lic. techn.

Department of Structural Engineering, TU
Copenhagen Lyngby, Denmark

SUMMARY

A rigid, perfectly plastic 3-parameter constitutive model for concrete is presented. The modified Coulomb failure criterion is adopted as a yield condition with the associated flow rule. The limited ductility is accounted for by neglecting the tensile strength in practical applications and replacing the compressive strength by a reduced effective strength. The dissipation in kinematical discontinuities is calculated, and the relationship between cracks and yield lines is discussed. References to applications of the model are given.

RÉSUMÉ

Un modèle rigide, parfaitement plastique à 3 paramètres constitutifs est introduit pour le béton. Le critère de rupture de Coulomb modifié est proposé comme critère de plasticité avec la règle d'écoulement associée. La ductilité limitée est prise en compte en négligeant la résistance en tension en applications pratiques et remplaçant la résistance en compression par une résistance effective réduite. La dissipation plastique dans des discontinuités kinématiques est calculée, et la relation entre fissures et lignes d'écoulement est discutée. Des références aux applications du modèle sont indiquées.

ZUSAMMENFASSUNG

Ein starr-ideal plastisches, 3-parametrisches Materialmodell für Beton wird besprochen. Das modifizierte Coulombsche Bruchkriterium ist als Fließbedingung mit dem zugeordneten Fließgesetz angenommen. Die begrenzte Duktilität wird durch Vernachlässigung der Zugfestigkeit in praktischen Anwendungen und durch Ersatz der Druckfestigkeit durch eine reduzierte effektive Festigkeit berücksichtigt. Die Dissipationsleistung in kinematischen Diskontinuitäten wird berechnet und die Relation zwischen Rissen und Fließlinien wird diskutiert. Hinweise auf Anwendungen des Modelles werden gegeben.

1. INTRODUCTION

In order to make realistic predictions about the behaviour of structures under applied loads, it is necessary to model the response of the materials from first loading to failure. However, if attention is restricted to the strength of the structure, a short-cut can be made by considering the state of collapse only. This is accomplished by using the theory of plasticity and applying the theorems of limit analysis, which are valid under certain idealized constitutive assumptions.

The theory of plasticity is a branch of the strength of materials, which can be traced back to the work of GALILEO [1638], who determined the failure moment of a beam composed of a material with infinite compressive strength (p 115, op.cit.). COULOMB [1776] established a yield (or rather failure) criterion (cf. Section 2 below), and gave an engineering formulation of the upper bound theorem (p 343-344, op. cit.). The plastic potential was introduced by v. MISES [28.1] who, in a generalization of earlier work, proved that the work done by a given plastic strain rate is stationary in the actual state with respect to varying stress states satisfying the yield criterion. Significant work was carried out in the Soviet Union in the thirties and forties, cf. GVOZDEV [49.1].

In fact, the theorems of limit analysis were stated by GVOZDEV [38.1], but his work was not widely known and credited in the West till much later. The commonly cited formulation is due to DRUCKER, PRAGER, & GREENBERG [52.2] and is based upon variational theorems proved by HODGE & PRAGER [48.2] and HILL [50.1]. PRAGER [55.1] and KOITER [53.2] extended the theorems to bodies with singular yield surfaces.

The plasticity theory of Gvozdev was formulated with explicit reference to structural concrete. On the other hand, the school of Prager and Hill was mostly concerned with metallic bodies, and concrete was long regarded as a brittle material, generally unfit for plastic analysis. The implications of applying rigorous limit analysis to reinforced concrete structures were discussed by DRUCKER [61.1].

When plasticity is applied to reinforced concrete structures, a main problem is the formulation of a suitable constitutive description of the concrete. Early investigations of plane elements relied upon the square yield locus for plane stress (cf. below), which may be generalized into the modified Coulomb yield condition, used by CHEN & DRUCKER [69.1] to treat a problem of plain concrete. Within the last decade, this material model has been applied to a number of non-standard cases, mainly shear in plain and reinforced concrete, by a research group at the Technical University of Denmark, NIELSEN & al. [78.7], BRAESTRUP & al. [78.1], JENSEN [77.2]. Similar research has been carried out at various other institutions, notably the Swiss Institute of Technology, MUELLER [78.6], MARTI [80.4]. In May 1979 a Colloquium on Plasticity in Reinforced Concrete was organized in Copenhagen, sponsored by the International Association for Bridge and Structural Engineering. Most of the results obtained so far are collected in the conference reports [78.3],[79.5].

The collapse of a structure is characterized by large irreversible deformations. By comparison, the elastic geometry changes are small, and in the absence of stability problems they may conveniently be neglected. Also work-hardening effects are without great importance for the collapse load. Thus the structure is idealized as a rigid, perfectly plastic body.

The theory of perfect plasticity only involves the rates or increments of plastic strains, and does not predict the magnitude of the total deformations. However, when we describe the structure as rigid-plastic, and only consider the instant of collapse, then the incipient plastic deformations are the first and

only to occur, and it is immaterial whether they are regarded as increments or not. Consequently, the use of superposed dots is avoided, and although the term "rate" is employed, the distinction from conventional "small strains" is merely academical.

The constitutive equations of plasticity and the validity of the limit analysis theorems require unlimited ductility, i.e. the materials shall be able to undergo arbitrarily large deformations at constant stress level. Apparently concrete cannot be considered to satisfy this requirement to any reasonable degree. An abstract discussion of this matter is quite complicated and rather futile. Instead it is proposed to regard the theory of plasticity as a mathematical tool by which it is possible to describe the behaviour of concrete structures at collapse. The merits of the approach will then have to be judged by the correspondence between the theoretical predictions and experimental evidence.

2. MODIFIED COULOMB CRITERION

One of the simplest descriptions of the strength of a material is the frictional hypothesis introduced by COULOMB [1776], stating that in a section subjected to the shear stress τ and the normal stress σ failure occurs for

$$\tau = c - \sigma \tan \varphi \quad (1)$$

Thus the strength is defined by two material parameters, the cohesion c and the angle of internal friction φ . For $\varphi = 0$, the criterion reduces to Tresca's condition of maximum shear stress.

For a material obeying equation (1), the uniaxial tensile strength f_t and compressive strength f_c are:

$$f_t = \frac{2c}{\sqrt{k}} \quad \text{and} \quad f_c = 2c\sqrt{k} \quad (2a,b)$$

$$\text{where } k = \frac{1 + \sin \varphi}{1 - \sin \varphi} \quad (3)$$

The Coulomb criterion is used mainly for soils, but it may also be applied to other granular materials, such as concrete. One drawback of the model is that for reasonable values of the angle of friction, the ratio between tensile and compressive strength, implied by equations (2), is unrealistically high. This can be amended by introducing Rankine's maximum stress criterion, stating that tension failure occurs for

$$\sigma = f_t \quad (4)$$

The combination of equations (1) and (4) is called the modified Coulomb failure criterion, visualized in Fig. 1.

COULOMB [1776], p 348-349, attempted to determine the cohesion of a material by loading a specimen in pure shear, and found that failure occurred for a shear load approximately equal to that required to break the specimen in direct tension. This led Coulomb to identify the cohesion c with the tensile strength f_t . As seen from equation (2a), this is in fact correct for a Coulomb material with $k = 4$, corresponding to $\tan \varphi = 0.75$, which is precisely the value adopted by Coulomb in his applications, cf. HEYMAN [72.1], p 120-121. However, if the Coulomb criterion is valid, then failure in pure shear will occur at a shear stress which is less than the tensile strength f_t , cf. Fig. 2. The fact that the same value was obtained shows that the material (a sandstone) obeys a modified Coulomb criterion, where tension failure takes place by separation rather than by sliding. For such materials, the cohesion is substantially higher than



the uniaxial tensile strength, as seen in Fig. 2.

The idea of combining the criteria of maximum shear stress and maximum normal stress appears to be due to DORN [48.1], in the case of cast iron. For concrete, the combination of Coulomb sliding failure and Rankine separation failure was suggested by COWAN [53.1], PAUL [61.2], and SANDBYE [65.1].

Fig. 1 shows the modified Coulomb criterion as the envelope of the Mohr's circles for the states of stress which can be sustained on a section in the material, and such a failure criterion was proposed by MOHR [1900]. Mohr's failure envelope is also called the intrinsic curve of the material, and COWIN [74.1] has shown that the Mohr-Coulomb criterion follows from a simple constitutive assumption.

Many suggestions have been made for the shape of the failure envelope. One of the earliest is a parabola, cf. LEON [35.1], reflecting the experimental fact that the angle of friction, i.e. the slope of the curve, decreases with increasing compressive stress. On the other hand, the parabola is defined by two parameters only, whereas the modified Coulomb criterion has the attractive feature that the tensile strength may be varied independently of the compressive strength and the angle of friction.

The failure envelope of Fig. 1 is open towards the negative direction of the σ -axis, which means that theoretically the material is able to sustain arbitrarily high hydrostatic compression. It is further characteristic for any Mohr-Coulomb criterion that it does not involve the intermediate principal stress, which does have some influence, according to modern investigations. To take account of these defects, various more sophisticated criteria have been formulated, e.g. MAGNAS & AUDIBERT [71.1], De GARIEL-THORON [77.1], DRAGON & MRÓZ [79.3], OTTOSEN [79.7].

Failure of concrete may also be defined as the onset of unstable internal cracking, depending upon the loading path, KOTSOVOS & NEWMAN [78.4], [79.6], or defined by a limiting volumetric strain, CARINO & SLATE [76.1]. A maximum strain criterion, LOWE [78.5], leads to a model which is very similar to the modified Coulomb condition. Surveys of failure criteria for concrete are also given by CHEN [78.2] and WASTIELS [79.8].

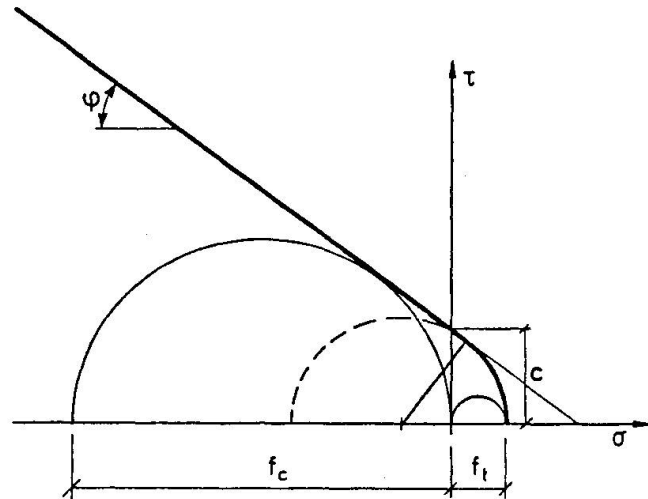

Fig. 1 Modified Coulomb failure criterion

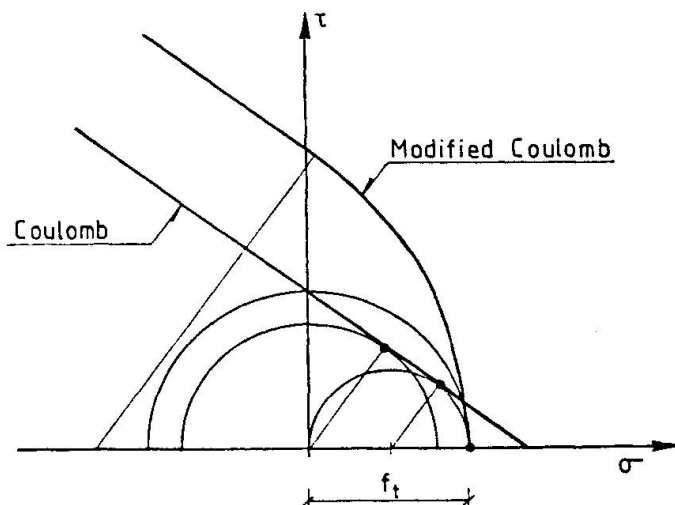

Fig. 2 Modified and unmodified Coulomb criteria with Mohr's circles of stress for pure shear and uniaxial tension

3. CONSTITUTIVE MODEL FOR CONCRETE

To be able to subject structural concrete to plastic analysis, we introduce the assumption:

Concrete is regarded as a rigid, perfectly plastic material with the modified Coulomb failure criterion as yield condition and with the associated flow rule. The compressive strength is f_c^* , the tensile strength is f_t^* , and the angle of friction is φ .

When the failure criterion of Fig. 1 is adopted as yield condition, the yield surface can be determined in the space of principal stresses $(\sigma_1, \sigma_2, \sigma_3)$. Fig. 3 shows the yield loci in the cases of plane strain and plane stress. They are found from the yield surface by projecting on, respectively intersecting with, the plane $\sigma_3 = 0$. Figure 3 also illustrates the associated flow rule, the generalized strain rates being the principal strain rates $(\epsilon_1, \epsilon_2, \epsilon_3)$. The slope of the yield locus corresponding to sliding failure is determined by the parameter k , given by equation (3).

The validity of the associated flow rule for granular materials like concrete is questionable. It is obvious that concrete dilates at failure, but experimental evidence seems to indicate that it is not nearly as much as predicted by the normality condition. However, tests of this kind are difficult to interpret because they are based upon an assumed uniform state of deformation, and failure of concrete (and rock) tend to be localized in narrow zones, cf. Section 5 below.

The constitutive description of concrete, introduced above, is very crude in the sense that it attempts to define the strength properties and the deformations at failure by means of only three material parameters, viz. f_c^* , f_t^* , and φ . It would have no purpose to pretend that such a primitive model is particularly realistic, and the approach is open to criticism, BAZANT & TSUBAKI [80.2]. On the other hand, surprisingly accurate predictions may be obtained, provided some care is taken in the definition of the strength parameters.

The stress-strain curve of concrete in compression is characterized by the total absence of a yield plateau and by a falling branch. Consequently, the redistribution of stresses, which is a condition for the validity of the limit analysis theorems, can only take place at the expense of losing strength. This is taken into account by assuming f_c^* , called the effective concrete strength, to be a certain fraction of the uniaxial compressive strength f_c , estimated by standard tests (cylinders, prisms, cubes, etc.). The ratio $v = f_c^*/f_c$ is called the effectiveness factor, and

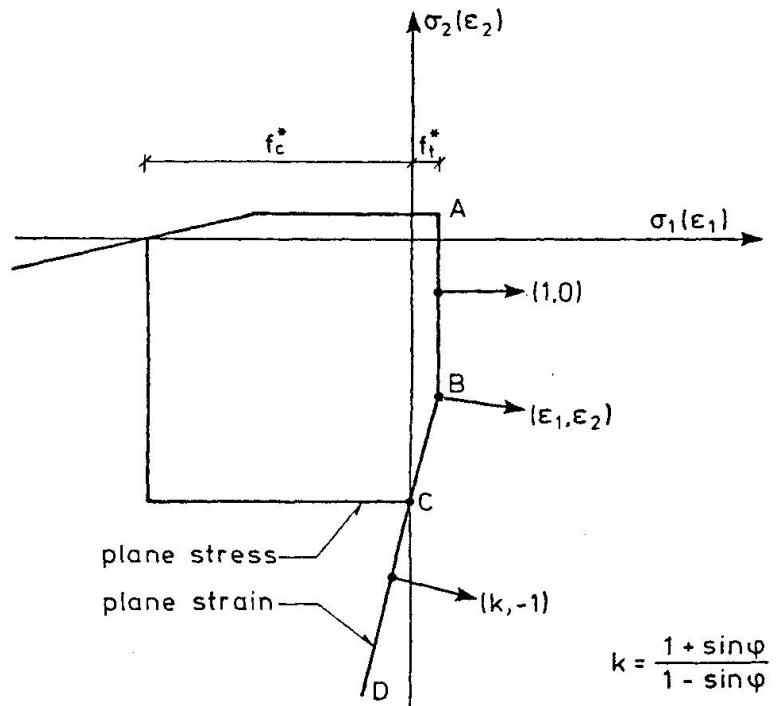

Fig. 3 Yield loci for concrete in plane stress and plain strain



since it is primarily a measure of concrete ductility, it decreases with increasing strength level. Empirical investigations have shown that this trend may be described by assuming the effective strength f_c^* to be proportional to $\sqrt{f_c}$. Incidentally, the same empirical relationship appears to exist between the tensile strength f_t and the compressive strength f_c .

A theoretical estimate of the effective concrete strength may be obtained, EXNER [79.4], by requiring the strain energy (i.e. the area under the stress-strain curve) for a certain limiting strain ϵ_g to be identical for the actual and the idealized materials. Based upon experimentally determined stress-strain curves, the effectiveness factor is then found as a function of the compressive strength f_c , which is very similar to the square root dependency described above. COLLINS [79.2] finds that the effective concrete strength does not only depend upon the value of the corresponding principal compressive strain, but also on the magnitude of the co-existing maximum shear strain.

In addition to reflect the ductility, the effectiveness factor must also incorporate all the effects which are not explicitly accounted for in the theory, e.g. initial state of stress, stiffness of the materials, size effects, etc. Therefore the effectiveness factor for a given type of structure will have to be evaluated by comparing the predictions of plastic analysis with results of tests.

The behaviour of concrete in tension is almost brittle, hence the effective tensile strength f_t^* is very small. If $f_t^* = 0$ is assumed, the lack of ductility in tension becomes immaterial, and the theorems of limit analysis may be applied with confidence. Problems arise if the strain rates change from tensile to compressive, but that is not relevant for simple yield point analysis. Consequently, the tensile concrete strength is prudently neglected for all practical purposes, which means that reinforcement must be provided if tensile stresses cannot be avoided. For $f_t^* = 0$, the yield locus for plane stress (fig. 3) reduces to the so-called square yield locus for concrete, cf. Fig. 4.

The angle of internal friction appears to be fairly independent of the concrete quality, and ample experimental evidence suggests the value $\varphi = 37^\circ$, corresponding to $\tan\varphi = 0.75$ and $k = 4$. This value corresponds to the slope of the experimental Mohr-Coulomb failure envelope for stress states in the vicinity of $(\sigma_1, \sigma_2, \sigma_3) = (0, 0, -f_c)$. As mentioned in Section 2, the angle of friction is reduced by the superposition of a high hydrostatic compression. Sometimes substantially higher angles of friction are quoted, BAZANT & TSUBAKI [79.1], [80.2], based upon the shear transfer in cracks. However, what is effectively measured by such tests is the slope of the modified Coulomb criterion, Fig. 1, at the intersection with the τ -axis.

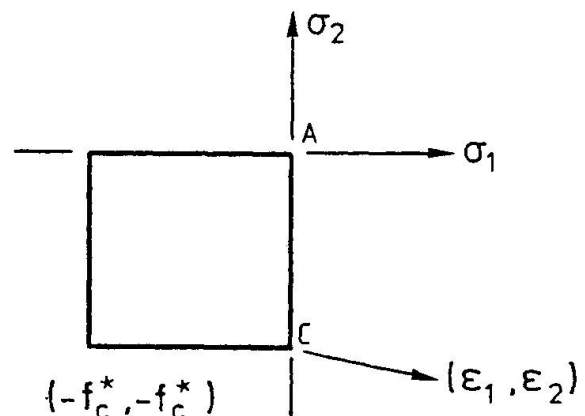

Fig. 4 Square yield locus for concrete in plane stress

The modified Coulomb criterion with a zero tension cut-off was used by DRUCKER & PRAGER [52.1] as a yield condition for soil. For concrete, CHEN & DRUCKER [69.1] introduced a non-zero tensile strength. The yield condition has been discussed by CHEN [70.1] and JENSEN [77.2].

The square yield locus for concrete in plane stress was applied by NIELSEN [64.1] to slabs, and later to walls, NIELSEN [71.2], and shear in beams, NIELSEN [67.1].

In the latter context, NIELSEN [69.2] introduced the concept of effective concrete strength.

4. CONSTITUTIVE MODEL FOR REINFORCEMENT

For the steel reinforcement, we introduce the assumption:

The reinforcing bars are regarded as rigid, perfectly plastic, and able to resist forces in their axial direction only. The tensile yield stress of the steel is f_y .

It follows that dowel action of the bars is neglected. So is usually the contribution from compressed reinforcement, because it is small in comparison with that of the surrounding concrete. The one-dimensional yield locus for steel subject-

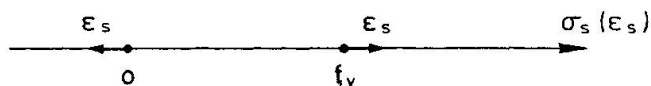

ed to the axial stress σ_s is visualized in Fig. 5. For steel without a definite yield point, the yield stress f_y is defined in a suitable manner, e.g. as the 0.2% offset strength.

The reinforcement is assumed to be either concentrated in lines (stringers) or continuously distributed over the section (smeared). In the latter case, the bars are assumed to be parallel and sufficiently closely spaced. The tensile strength of a stringer is the yield force $T = A_s f_y$, where A_s is the cross-sectional steel area. The strength of smeared reinforcement is characterized by the equivalent yield stress $r f_y$, where r is the reinforcement ratio, defined as

$$r = \frac{A_s}{A_c} \quad (5)$$

Here A_c is the area of the section of concrete perpendicular to the bars of area A_s .

The actions of reinforcement in different directions are assumed to be independent. Generally, problems with bond and anchorage are neglected. Thus perfect bond is assumed in upper bound solutions. In lower bound solutions, any stress transfer, including complete slip, is possible.

5. DISSIPATION IN YIELD LINES

In the derivation of upper bound solutions, it is very convenient to use failure mechanisms where the deformations are localized in failure surfaces, separating rigid parts of the body. The angle between the relative displacement rate v and the surface is termed α , where $-\pi/2 \leq \alpha \leq \pi/2$, cf. Fig. 6b. The intersection of the failure surface with the normal plane containing the displacement vector is called a yield line. The yield line is a kinematical discontinuity which may be regarded as an idealization of a narrow zone of depth Δ with high strain rates, assumed to be homogeneous, cf. Fig. 6a.

In the normal plane, the local components of the strain rates are

$$\epsilon_n = \frac{v}{\Delta} \sin \alpha, \quad \epsilon_t = 0, \quad \varphi_{nt} = 2\gamma_{nt} = \frac{v}{\Delta} \cos \alpha$$

The transformation formulae (Mohr's circle) then yield the principal strain rates:

$$\epsilon_1 = \frac{v}{2\Delta} (1 + \sin \alpha) \quad \text{and} \quad \epsilon_2 = -\frac{v}{2\Delta} (1 - \sin \alpha) \quad (6a,b)$$

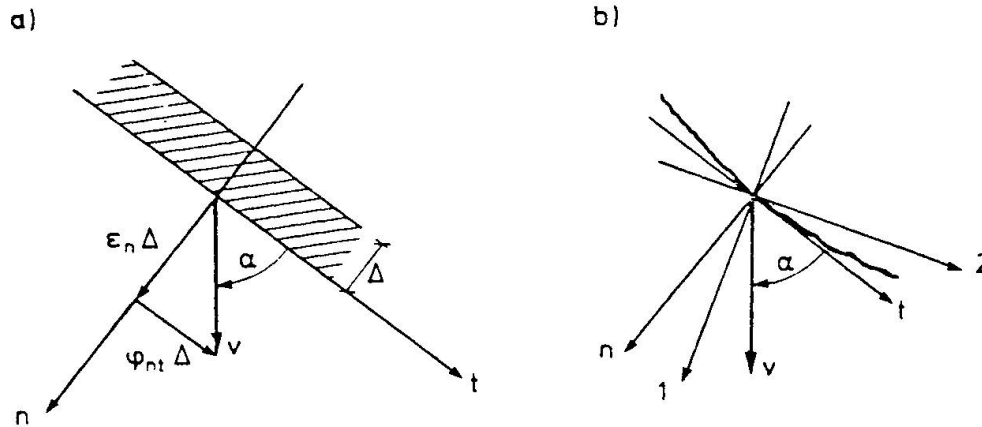

Fig. 6 Yield line in plain concrete
 a) Narrow zone with high straining
 b) Kinematical discontinuity

The principal directions of strain rate, which coincide with the principal directions of stress, are indicated in Figs. 6. The first principal axis bisects the angle between the deformation vector and the yield line normal.

In the cases of plane stress ($\sigma_3 = 0$) or plane strain ($\epsilon_3 = 0$), the rate of internal work per unit area of the discontinuity is

$$D = (\epsilon_1 \sigma_1 + \epsilon_2 \sigma_2) \quad (7)$$

Referring to equations (6), note that the dissipation is independent of the assumed depth Δ of the deforming zone.

The principal stresses (σ_1, σ_2) which are able to produce the principal strain rates (ϵ_1, ϵ_2) given by equations (6) are determined by the flow rule and the yield condition, Fig. 3. The stress regime on the yield locus depends upon the direction of the strain rate vector, i.e. upon the value of α .

Inserting into equation (7), we find:

$$D = \frac{1}{2} v f_c^* (\lambda - m \sin \alpha) \quad (8)$$

$$\text{for } \varphi \leq \alpha \leq \pi/2 \quad (\text{plane stress or strain})$$

$$D = \frac{1}{2} v f_c^* (1 - \sin \alpha) \quad (9)$$

$$\text{for } -\pi/2 \leq \alpha \leq \varphi \quad (\text{plane stress})$$

Here the parameters λ and m are defined as

$$\lambda = 1 - (k-1) \frac{f_t^*}{f_c^*}, \quad m = 1 - (k+1) \frac{f_t^*}{f_c^*} \quad (10a,b)$$

Note that equations (8) and (9) are identical for $\alpha = \varphi$. Equation (9) is valid for plane stress only, because the flow rule and the yield condition exclude yield lines with $\alpha < \varphi$ in the case of plane strain. To describe such deformations, it would be necessary to introduce a more sophisticated constitutive model, e.g. by assuming a curved failure envelope (cf. Fig. 1) or a non-associated flow rule.

The derivation of equations (8) and (9) is explained in further detail by JENSEN [75.1], cf. also [78.6]. General formulae for the dissipation in a modified Coulomb material are given by JENSEN [77.2].

Suppose a reinforcement stringer intersects a yield line at the angle β , where $0 \leq \beta \leq \pi$ and $\beta = 0$ corresponds to the same direction as $\alpha = 0$, cf. Fig. 7. The rate of strain ϵ_s in the stringer is then

$$\epsilon_s = \frac{v}{\Delta} \sin\beta \cos(\beta - \alpha)$$

The rate of internal work is determined by the flow rule and the yield condition, Fig. 5:

$$W_I = v T_y \cos(\beta - \alpha) \quad \text{for } \beta - \alpha \leq \pi/2 \quad (11)$$

$$W_I = 0 \quad \text{for } \beta - \alpha \geq \pi/2$$

If the yield line is crossed by a band of smeared reinforcement, the contribution to the rate of internal work per unit area of the discontinuity is

$$D = v r f_y \cos(\beta - \alpha) \sin\beta \quad \text{for } \beta - \alpha \leq \pi/2 \quad (12)$$

$$D = 0 \quad \text{for } \beta - \alpha \geq \pi/2$$

The factor $\sin\beta$ takes account of the fact that the reinforcement ratio r is defined per unit area perpendicular to the reinforcement, cf. equation (5).

6. CRACKS AND YIELD LINES

Cracks in concrete are damages which are always present at the micro-level, and may occur for a number of reasons, including changes in temperature and humidity. Under load, visible cracks tend to form perpendicular to the direction of first principal stress. Thus from Figs. 6 we conclude that a yield line will only coincide with the crack direction provided that it is perpendicular to the relative displacement rate. In that case, the yield line may be termed a collapse crack, MUELLER [76.2],[78.6].

During a loading history leading to collapse, the principal axes (and the cracks) are likely to change directions, and at failure the latest formed cracks will generally be at an angle to the yield line. This means that shear stresses are transferred across the discontinuity, presumably by aggregate interlock in old cracks and by crushing zones between cracks.

The transfer of shear in yield lines is expressed by the rate of work dissipated, which depends upon the direction α of the deformation, cf. Figs. 6. For $\alpha = \pi/2$, equation (8) reduces to $D = v f_c^*$, i.e. the resistance of concrete to cracking is equal to the tensile strength. However, as soon as a tangential deformation is introduced ($\alpha < \pi/2$), the resistance increases dramatically, and the compressive strength becomes dominant.

If the tensile strength is neglected, the stress state in the yield line is given by the corner C of the yield locus, Fig. 3, for $\varphi < \alpha < \pi/2$ in plane strain and $-\pi/2 < \alpha < \pi/2$ in plane stress ($-\pi/2 < \alpha < \varphi$ in the case of finite tensile strength). Hence the principal stresses are $(\sigma_1, \sigma_2) = (0, -f_c^*)$, corresponding to the local stresses in the yield line (cf. Figs. 6):

$$\sigma_n = -\frac{1}{2} f_c^* (1 - \sin\alpha) \quad , \quad \tau_{nt} = \frac{1}{2} f_c^* \cos\alpha \quad (13a,b)$$

Note that the shear stress increases to a maximum of half the compressive strength in the case of pure shearing ($\alpha = 0$).

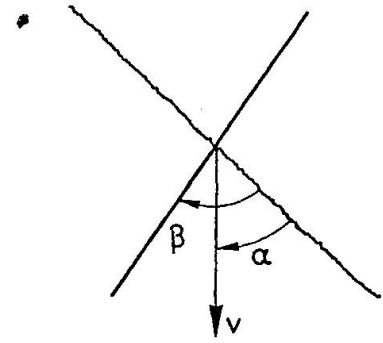

Fig. 7 Yield line with reinforcing bar



To minimize the rate of internal work, concrete will tend to fail mainly by cracking, with as little shearing as possible. The efficiency of steel bars as reinforcement is to a large extent due to the restraint they offer against the dilation of cracking concrete. The principal merit of the modified Coulomb condition is that it offers a simple and rational description of this behaviour.

The adoption of a zero tensile strength is equivalent with the assumption that the concrete is potentially cracked in all directions, whether cracks are detected or not. Still, the concrete behaves as an isotropic material, in the sense that the cracks in one direction do not affect the strength in other directions, unless the cracking is associated with significant strains, cf. Section 3. It might be feared that the presence of cracks would reduce the resistance to sliding failure in certain directions. However, experience indicates that the crack width should be very large (several millimeters) before the shear transfer is significantly reduced.

A different approach is that of BAZANT & TSUBAKI [79.1],[80.2]. They regard cracks as unable to transfer shear without the presence of compressive stresses, but rather than describe this behaviour by the modified Coulomb criterion with a zero tensile strength they introduce a so-called slip-free criterion, which is effectively the Coulomb criterion with zero cohesion (cf. BRAESTRUP [80.3]). For isotropic concrete this implies zero compressive strength, but the criterion is intended for concrete under predominantly tensile loading, and with large crack openings. Thus the cracked concrete is assumed to be anisotropic. A constitutive model for cracked concrete valid for small crack displacements has recently been proposed by BAZANT & GAMBAROVA [80.1].

7. APPLICATIONS OF THE MODEL

Early applications of plasticity to structural concrete consists of cases where the strength is mainly governed by the reinforcement, e.g. flexure of beams and slabs, and for such problems, the use of a plastic approach has become standard. Prominent examples are the yield hinge method for beams and frames, BAKER [56.1], and the yield line theory for slabs, JOHANSEN [43.1]. In these cases, the role of the concrete is merely to provide a suitable compression zone.

Plastic analysis of concrete structures subjected primarily to shear loads represents a comparatively new development. Such non-classical applications include in-plane shear in overreinforced (constrained) walls, shear in joints, shear in slender beams with vertical, inclined or no stirrups, shear in deep beams and corbels, punching shear and pull-out, concentrated loading, anchorage and bond. A common feature of these problems is that the strength of the structure is largely dependent upon the concrete properties, which means that the constitutive model for the concrete plays a dominant part.

The predictions of the plastic analysis have been compared with experimental evidence, and in most cases a remarkable qualitative agreement has been found. The quantitative agreement hinges upon the assumed values of the effective strength parameters, cf. Section 3. It appears that reasonable strength predictions are obtained by neglecting the tensile strength f_t^* and adopting an effectiveness factor $v = f_t^*/f_c$ of the order of $v = 0.5$, f_c being the cylinder strength.

A detailed account of the individual applications is outside the scope of the present paper, and the reader is referred to the papers and reports mentioned in Section 1, as well as to a monograph by NIELSEN and a thesis by BRAESTRUP, both in preparation. A summary of the results will also appear as a chapter of a forthcoming Handbook of Structural Concrete.

8. DISCUSSION

Mathematical models for material response are tools by which engineers may predict the strength and deformations of structures. By introducing a sufficiently large number of constitutive parameters it is possible to describe the behaviour of the most complex material to any desired degree of accuracy. The computational difficulties arising from the application of such complicated models can be overcome by the use of numerical methods adapted for large electronic computers. However, the machine does not give any indications on how to assign realistic values to the various material parameters in any particular application.

In the preceding sections we have introduced a description of concrete at ultimate which is extremely simple, in the sense that it relies upon only three parameters, which are easily evaluated, the physical significance being straightforward. If the tensile strength f_t^* is neglected, and the standard value $\phi = 37^\circ$ is adopted for the angle of friction, then the only parameter left to characterize the material is the effective concrete strength f_c^* , which essentially is a conservative estimate of the uniaxial compressive strength.

It is obvious that such a primitive model cannot furnish any detailed description, even when attention is restricted to strength properties. Nevertheless, experience indicates that surprisingly good predictions are obtained concerning the failure of structures in plain and reinforced concrete.

It appears that the best results are produced for problems involving plane stress. For plane strain, and particularly axisymmetric cases, the solutions tend to significantly overestimate the load-carrying capacity. This is probably due to the fact that the yield condition is unconservative in the presence of high hydrostatic compression. A refinement of the model should address that problem, e.g. by substituting a curved failure envelope for the straight line of the Coulomb criterion, cf. Fig. 1.

A reasonable amendment would be to replace equation (1) by the parabola:

$$\tau^2 = \frac{1}{4} f_c^2 (1 - \sin\phi)^2 - \sigma f_c \sin\phi \quad (14)$$

This failure envelope has the property that the inclination is equal to ϕ for the stress state corresponding to uniaxial compression. The tension cut-off, equation (4), only becomes effective for a tensile strength $f_t < \frac{1}{4} f_c (1 - \sin\phi)^2 / \sin\phi$.

The modified failure envelope is shown in Fig. 8 for $f_t = 0$. Note that in this case the yield locus for plane stress still is the square yield locus, cf. Fig. 4. For plane strain the lines with slope k (Fig. 3) are replaced by hyperbolas with asymptotes parallel with the hydrostatic axis. Thus plain strain yield lines with deformation inclinations $\alpha < \phi$ become possible, albeit the resistance against pure shearing ($\alpha = 0$) is infinite. This should lead to a better description of axisymmetric problems without the introduction of additional parameters.

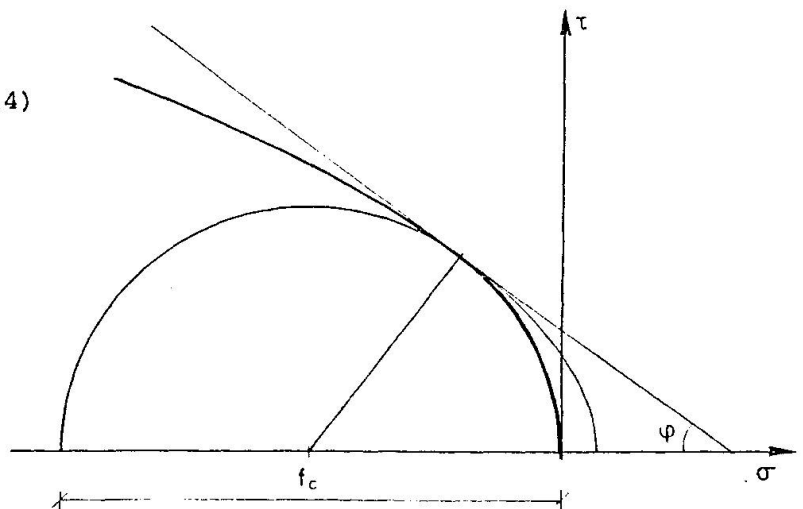

Fig. 8 Parabolic failure envelope with zero tension cut-off.



ACKNOWLEDGEMENTS

The research reported has been carried out at the Department of Structural Engineering (ABK) of the Technical University of Denmark under a grant from the Danish Council for Scientific and Technical Research. The material for the present paper is partly extracted from a thesis under preparation.

REFERENCES

- [1638] GALILEO: Discorsi e Dimostrazioni Matematiche intorno à due nuove Scienze Attenenti alla Mecanica & i Movimenti Locali. Leyden, Elsevirs, 1638. (English translation: Dialogues concerning Two New Sciences. New York, Dover Publ. 1950, 294 pp.)
- [1776] COULOMB, C.A.: Essai sur une application des règles de maximis & minimis à quelques problèmes de statique, relatifs à l'architecture. Mémoires de Mathématique & de Physique Présentés à l'Académie Royale des Sciences, Vol. 7, 1776, pp. 343-382. (English translation: HEYMAN [72.1], pp. 41-74)
- [1900] MOHR, O.: Welche Umstände bedingen die Elastizitätsgrenze und den Bruch eines Materials. Zeitschrift des Vereines deutscher Ingenieure, Vol. 44II, 1900, pp. 1524-1530, 1572-1577.
- [28.1] MISES, R.v.: Mechanik der plastischen Formänderung von Kristallen. Zeitschrift für Angewandte Mathematik und Mechanik, Vol. 8, 1928, pp. 161-185.
- [35.1] LEON, A.: Ueber die Scherfestigkeit des Betons. Beton und Eisen, Vol. 34, No. 8, 1935, pp. 130-135.
- [38.1] GVOZDEV, A.A.: Opređenje veličiny razrushayushchei nagruzki dlya staticheskoi neopredelimoj sistemy, preterpevayushchikh plasticheskie deformatsii. Sbornik trudov konferentsii po plasticheskim deformatsiyam, Moscow-Leningrad, Akademia Nauk SSSR, 1938, pp. 19-30. (English translation: The determination of the value of the collapse load for statically indeterminate systems undergoing plastic deformation. International Journal of Mechanical Sciences, Vol. 1, 1960, pp. 322-333.)
- [43.1] JOHANSEN, K.W.: Brudlinieteorier. Copenhagen, Gjellerup, 1943, 189 pp. (English translation: Yield-Line Theory. London, Cement and Concrete Association, 1962).
- [48.1] DORN, J.E.: The effect of stress state on the fracture strength of metals. Fracturing of Metals, Cleveland, Ohio, American Society of Metals, 1948, pp. 32-50.
- [48.2] HODGE, P.G. & PRAGER, W.: A variational principle for plastic materials with strainhardening. Journal of Mathematics and Physics, Vol. 27, No. 1, 1948, pp. 1-10.
- [49.1] GVOZDEV, A.: Raschet nesushchei sposobnosti konstruktsii po metodu predelnogo ravnoveiya. (Analysis of the load-carrying capacity of structures by the method of limiting equilibrium). Moscow, Stroiizdat, 1949, 280 pp.
- [50.1] HILL, R.: The Mathematical Theory of Plasticity. Oxford, Clarendon Press, 1950, 356 pp.
- [52.1] DRUCKER, D.C. & PRAGER, W.: Soil mechanics and plastic analysis or limit design. Quarterly of Applied Mathematics, Vol. 10, 1952, pp. 157-165.
- [52.2] DRUCKER, D.C., PRAGER, W. & GREENBERG, H.J.: Extended limit design theorems for continuous media. Quarterly of Applied Mathematics, Vol. 9, 1952, pp. 381-389.
- [53.1] COWAN, H.J.: The strength of plain, reinforced and prestressed concrete under the action of combined stresses, with particular reference to the combined bending and torsion of rectangular sections. Magazine of Concrete Research, Vol. 5, 1953, pp. 75-86.
- [53.2] KOITER, W.T.: Stress-strain relations, uniqueness and variational theorems for elastic-plastic materials with singular yield surfaces. Quarterly of Applied Mathematics, Vol. 11, No. 3, 1953, pp. 350-354.

- [55.1] PRAGER, W.: The general theory of limit design. 8th International Congress of Theoretical and Applied Mechanics, Proc. Vol. II, 1955, pp. 65-72.
- [56.1] BAKER, A.L.L.: The Ultimate-Load Theory Applied to the Design of Reinforced and Prestressed Concrete Frames. London, Concrete Publications Ltd. 1956, 91 pp.
- [61.1] DRUCKER, D.C.: On structural concrete and the theorems of limit analysis. International Association for Bridge and Structural Engineering, Memoirs, Vol. 21, 1961, pp. 49-59.
- [61.2] PAUL, B.: A modification of the Coulomb-Mohr theory of fracture. Journal of Applied Mechanics, Vol. 28, June 1961, pp. 259-268.
- [64.1] NIELSEN, M.P.: Limit analysis of reinforced concrete slabs. Copenhagen, Acta Polytechnica Scandinavica, Civil Engineering and Building Construction Series No. 26, 1964, 167 pp.
- [65.1] SANDBYE, P.: A plastic theory for plain concrete. Bygningssatiske Meddelelser, Vol. 36, No. 2, 1965, pp. 41-62.
- [67.1] NIELSEN, M.P.: Om forskydningsarmering i jernbetonbjælker. (On shear reinforcement in reinforced concrete beams). Bygningssatiske Meddelelser, Vol. 38, No. 2, 1967, pp. 33-58.
- [69.1] CHEN, W.-F. & DRUCKER, D.C.: Bearing capacity of concrete blocks or rock. Journal of the Engineering Mechanics Division, Proc. ASCE, Vol. 95, No. EM4, Aug. 1969, pp. 955-978.
- [69.2] NIELSEN, M.P.: Discussion on NIELSEN [67.1]. Bygningssatiske Meddelelser, Vol. 40, No. 1, 1969, pp. 60-63.
- [70.1] CHEN, W.-F.: Extensibility of concrete and theorems of limit analysis. Journal of the Engineering Mechanics Division, Proc. ASCE, Vol. 96, No. EM3, June 1970, pp. 341-352.
- [71.1] MAGNAS, J.-P. & AUDIBERT, A.: Critères de résistance du béton sous sollicitations multiaxiales. Annales de l'Institut Technique du Bâtiment et des Travaux Publics, No. 287, Nov. 1971, pp. 22-43.
- [71.2] NIELSEN, M.P.: On the strength of reinforced concrete discs. Copenhagen, Acta Polytechnica Scandinavica, Civil Engineering and Building Construction Series No. 70, 1971, 261 pp.
- [72.1] HEYMAN, J.: Coulomb's Memoir on Statics: An Essay in the History of Civil Engineering. Cambridge University Press, 1972, 212 pp.
- [74.1] COWIN, S.C.: Constitutive relations that imply a generalized Mohr-Coulomb criterion. Acta Mecanica, Vol. 20, 1974, pp. 41-46.
- [75.1] JENSEN, B.C.: Lines of discontinuity for displacements in the theory of plasticity of plain and reinforced concrete. Magazine of Concrete Research, Vol. 27, No. 92, Sep. 1975, pp. 143-150.
- [76.1] CARINO, N.J. & SLATE, F.O.: Limiting tensile strain criterion for failure of concrete. Journal of the American Concrete Institute, Proc. Vol. 73, No. 3, Mar. 1976, pp. 160-165.
- [76.2] MUELLER, P.: Failure mechanisms for reinforced concrete beams in torsion and bending. International Association for Bridge and Structural Engineering, Memoirs, Vol. 36 II, 1976, pp. 147-163.
- [77.1] GARIEL-THORON, R.de: Un nouveau critère de plasticité: Application a la Mécanique des sols. Annales de l'Institut Technique du Bâtiment et des Travaux Publics, No. 349, Apr. 1977, pp. 117-152.
- [77.2] JENSEN, B.C.: Some applications of plastic analysis to plain and reinforced concrete. Copenhagen, Technical University of Denmark, Institute of Building Design, Report No. 123, 1977, 119 pp.
- [78.1] BRAESTRUP, M.W., NIELSEN, M.P. & BACH, F.: Plastic analysis of shear in concrete. Zeitschrift für Angewandte Mathematik und Mechanik, Vol. 58, No. 6, June 1978, pp. 3-14.
- [78.2] CHEN, W.-F.: Constitutive equations for concrete. IABSE [78.3], Oct. 1978, pp. 11-34.



- [78.3] IABSE. Plasticity in Reinforced Concrete. Introductory Report. Zürich, International Association for Bridge and Structural Engineering, Reports of the Working Commissions, Vol. 28, Oct. 1978, 172 pp.
- [78.4] KOTSOVOS, M.D. & NEWMAN, J.B.: Generalized stress-strain relations for concrete. Journal of the Engineering Mechanics Division, Proc. ASCE, Vol. 104, No. EM4, Aug. 1978, pp. 845-856.
- [78.5] LOWE, P.G.: Deformation and fracture of plain concrete. Magazine of Concrete Research, Vol. 30, No. 105, Dec. 1978, pp. 200-204.
- [78.6] MUELLER, P.: Plastische Berechnung von Stahlbetonscheiben und -Balken. Zürich, Eidgenössische Technische Hochschule, Institut für Baustatik und Konstruktion, Bericht Nr. 83 (ETH Diss. 6083), July 1978, 160 pp.
- [78.7] NIELSEN, M.P., BRAESTRUP, M.W., JENSEN, B.C. & BACH, F.: Concrete Plasticity. Beam Shear - Punching Shear - Shear in Joints. Copenhagen, Danish Society for Structural Science and Engineering, Special Publication, Oct. 1978, 129 pp.
- [79.1] BAŽANT, Z.P. & TSUBAKI, T.: Concrete reinforcing net: Optimum slip-free limit design. Journal of the Structural Division, Proc. ASCE, Vol. 105, No. ST2, Feb. 1979, pp. 327-346.
- [79.2] COLLINS, M.P.: Investigating the stress-strain characteristics of diagonally cracked concrete. IABSE [79.5], Aug. 1979, pp. 27-34.
- [79.3] DRAGON, A. & MRÓZ, Z.: A continuum model for plastic-brittle behaviour of rock and concrete. International Journal of Engineering Science, Vol. 17, No. 2, Feb. 1979, pp. 121-137.
- [79.4] EXNER, H.: On the effectiveness factor in plastic analysis of concrete. IABSE [79.5], Aug. 1979, pp. 35-42.
- [79.5] IABSE: Plasticity in Reinforced Concrete, Final Report. Zürich, International Association for Bridge and Structural Engineering, Report of the Working Commissions, Vol. 29, Aug. 1979, 360 pp.
- [79.6] KOTSOVOS, M.D. & NEWMAN, J.B.: A model of concrete behaviour under generalized stress. IABSE [79.5], Aug. 1979, pp. 19-26.
- [79.7] OTTOSEN, N.S.: Constitutive model for short-time loading of concrete. Journal of the Engineering Mechanics Division, Proc. ASCE, Vol. 105, No. EM1, Feb. 1979, pp. 127-141.
- [79.8] WASTIELS, J.: Failure criteria for concrete under multiaxial stress states. IABSE [79.5], Aug. 1979, pp. 3-10.
- [80.1] BAŽANT, Z.P. & GAMBAROVA, P.: Rough cracks in reinforced concrete. Journal of the Structural Division, Proc. ASCE, Vol. 106, No. ST4, Apr. 1980, pp. 819-842.
- [80.2] BAŽANT, Z.P. & TSUBAKI, T.: Discussion on BAŽANT & TSUBAKI [79.1]. Journal of the Structural Division, Proc. ASCE, Vol. 106, No. ST6, June 1980, pp. 1378-1383.
- [80.3] BRAESTRUP, M.W.: Discussion on BAŽANT & TSUBAKI [79.1]. Journal of the Structural Division, Proc. ASCE, Vol. 106, No. ST6, June 1980, pp. 1375-1378.
- [80.4] MARTI, P.: Zur plastischen Berechnung von Stahlbeton. Zürich, Eidgenössische Technische Hochschule, Institut für Baustatik und Konstruktion, Bericht Nr. 104, Oct. 1980, 176 pp.