

# Fibre RC deck slabs with diminished steel reinforcement

Autor(en): **Mufti, Aftab A. / Bakht, Baidar / Jaeger, Leslie G.**

Objektyp: **Article**

Zeitschrift: **IABSE reports = Rapports AIPC = IVBH Berichte**

Band (Jahr): **64 (1991)**

PDF erstellt am: **15.08.2024**

Persistenter Link: <https://doi.org/10.5169/seals-49341>

## **Nutzungsbedingungen**

Die ETH-Bibliothek ist Anbieterin der digitalisierten Zeitschriften. Sie besitzt keine Urheberrechte an den Inhalten der Zeitschriften. Die Rechte liegen in der Regel bei den Herausgebern.

Die auf der Plattform e-periodica veröffentlichten Dokumente stehen für nicht-kommerzielle Zwecke in Lehre und Forschung sowie für die private Nutzung frei zur Verfügung. Einzelne Dateien oder Ausdrucke aus diesem Angebot können zusammen mit diesen Nutzungsbedingungen und den korrekten Herkunftsbezeichnungen weitergegeben werden.

Das Veröffentlichen von Bildern in Print- und Online-Publikationen ist nur mit vorheriger Genehmigung der Rechteinhaber erlaubt. Die systematische Speicherung von Teilen des elektronischen Angebots auf anderen Servern bedarf ebenfalls des schriftlichen Einverständnisses der Rechteinhaber.

## **Haftungsausschluss**

Alle Angaben erfolgen ohne Gewähr für Vollständigkeit oder Richtigkeit. Es wird keine Haftung übernommen für Schäden durch die Verwendung von Informationen aus diesem Online-Angebot oder durch das Fehlen von Informationen. Dies gilt auch für Inhalte Dritter, die über dieses Angebot zugänglich sind.



## Fibre RC Deck Slabs with Diminished Steel Reinforcement

Dalles en béton renforcé de fibres et avec une armatures métallique réduite

Fahrbahnplatten aus Faserbeton mit reduzierter Stahlbewehrung

### Aftab A. MUFTI

Professor  
Techn. Univ. of Nova Scotia  
Halifax, NS, Canada

### Baidar BAKHT

Princ. Res. Eng.  
Minist. of Transp. of Ontario  
Downsview, ON, Canada

### Leslie G. JAEGER

Professor  
Techn. Univ. of Nova Scotia  
Halifax, NS, Canada

### 1. INTRODUCTION

It is now well-established that when concrete deck slabs of slab-on-girder bridges are subjected to concentrated loads an internal arching system develops in the slabs, preventing them from responding in a purely flexural mode. The presence of the internal arching system, by reducing the tensile stresses in the slab, causes the slab to fail in punching shear rather than in flexure [1,2,3]. Recognizing this mode of behaviour of deck slabs, some jurisdictions around the world (e.g. [4]) require the deck slabs of their bridges to be designed by taking account of this internal arching. Overlays of concrete mixed with chopped polypropylene fibres and without any steel reinforcement have already been applied successfully on existing decks. From this application there has emerged the idea of deck slabs with polypropylene Fibre-Reinforced Concrete (FRC) with little or no steel reinforcement. Since the deck slab is subjected to predominantly compressive stresses, the low modulus of elasticity of the fibres is not expected to be of concern, as it is in purely flexural slabs. The fibres are practically inert to deicing salts; accordingly a deck slab reinforced with these fibres should prove to be very durable.

### 2. EXPERIMENTAL SETUP

The Technical University of Nova Scotia (TUNS) has initiated a research program to investigate experimentally and analytically, the feasibility of constructing a deck slab with FRC and with limited or no steel reinforcement. The laboratory model used in this program, represents at half-scale, a two-girder bridge having a 200 mm thick slab on girders spaced at about 2.2 m and with a span of about 7.3 m. The details of the model are shown in Fig. 1 which also illustrates the setup for the application of a concentrated load at the centre of the slab. The first model was provided with no diaphragms at the supports and three intermediate diaphragms, at mid-span and each of the quarter span locations. For the second test, fairly substantial diaphragms were added at the supports. For both models, the necessary workability of the concrete mixed with the polypropylene fibres was achieved by adding extra water rather than by the use of customary super-plasticizers.

### 3. TEST OBSERVATIONS

The first model failed under a concentrated load of about 177 kN. The mode of failure was not that of pure flexure, nor did it resemble the punching shear type of failure observed in deck slabs incorporating steel reinforcement. The deck failed along two lines which were close to and roughly parallel with the girders. The second model failed at about 222 kN in practically the same mode as that of the first model. A 25% increase in the failure load clearly establishes the significance of diaphragms at the supports. Despite the fact that the failure mode of the FRC slab is somewhat different from its steel-reinforced counterpart, the failure load for the second model corresponds to about 890 kN, which is about 18 times the maximum permissible weight of one half of the axle of a vehicle. It is pointed, however, that unless the failure zone could be restricted to within the close proximity of the zone of load

application, the presence of other concentrated loads on the deck cannot be neglected as it can be in the case of the punching shear type of failure.

#### 4. FINITE ELEMENT MODELLING

The model was analyzed using the finite element program ADINA [5]. The analysis model incorporated 20-noded isoparametric solid elements to model the deck slab; 3-D beam elements to model longitudinal girders; and 3-D truss elements to model the transverse diaphragms. Figure 2 plots the load-deflection relationships under the load for different degrees of restraint provided by the transverse diaphragms. It can be seen from this figure that the restraint provided by the diaphragms has a significant influence on the failure load.

#### 5. CONCLUSIONS

Tests on the models have clearly pointed towards the feasibility of FRC slabs with little or no steel reinforcement. However, before such slabs are recommended to be incorporated in bridges, it is necessary to know more about their behaviour through full-scale static and fatigue-type tests. It remains to be seen whether localized failure under a concentrated load, as experienced with steel reinforcement, can be achieved in FRC slabs in the total absence of transverse steel reinforcement, or whether some diminished amount of transverse steel within, or just below, the deck slab will still be found to be necessary.

#### REFERENCES

1. Hewitt, B.E., An Investigation of the Punching Strength of Restrained Slabs with Particular Reference to the Deck Slabs of Composite I-Beam Bridges, Ph.D. Thesis, Queen's University, Kingston, Canada, 1972.
2. Hewitt, B.E. and Batchelor, de V., Punching Shear Strength of Restrained Slabs, ASCE Journal of the Structural Division, 101 (ST9), September 1975, pp. 1827-1853.
3. Faug, I.K., Worley, J.A. Burns, N.H. and Klinger, R.E., Behaviour of Ontario Type Bridge Decks on Steel Girders. Research Report 350-1, Center for Transportation Research, Bureau of Engineering Research, the University of Texas at Austin, Jan. 1986.
4. Ontario Highway Bridge Design Code, Ontario Ministry of Transportation and Communication, 2nd Edition, 1983.
5. ADINA, ADINA R and D Inc., 71 Elton Avenue, Watertown, USA.

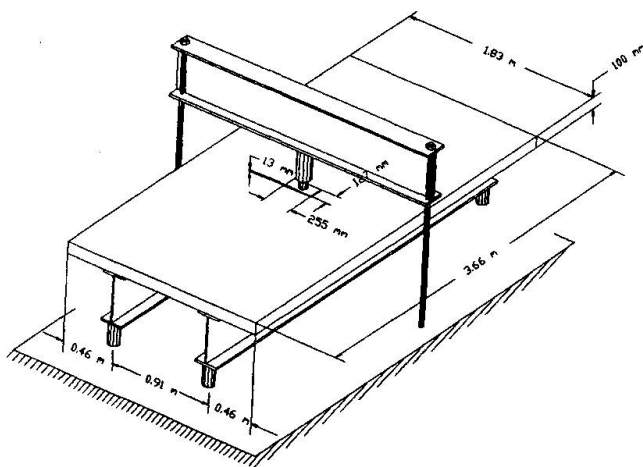

Figure 1. Details of the First Model

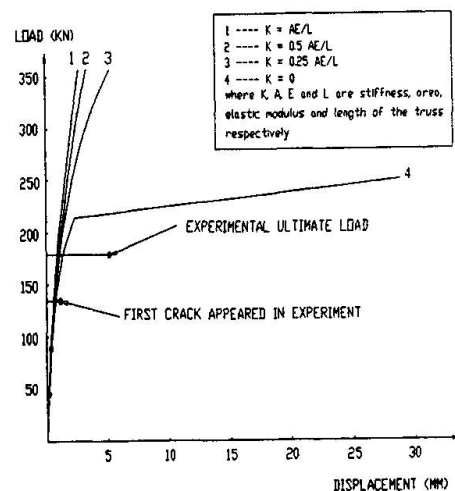

Figure 2. Load-deflection Curves

Leere Seite  
Blank page  
Page vide