

# Planches

Objektyp: **Group**

Zeitschrift: **Cahiers d'archéologie romande**

Band (Jahr): **90 (2002)**

PDF erstellt am: **26.09.2024**

## **Nutzungsbedingungen**

Die ETH-Bibliothek ist Anbieterin der digitalisierten Zeitschriften. Sie besitzt keine Urheberrechte an den Inhalten der Zeitschriften. Die Rechte liegen in der Regel bei den Herausgebern.

Die auf der Plattform e-periodica veröffentlichten Dokumente stehen für nicht-kommerzielle Zwecke in Lehre und Forschung sowie für die private Nutzung frei zur Verfügung. Einzelne Dateien oder Ausdrucke aus diesem Angebot können zusammen mit diesen Nutzungsbedingungen und den korrekten Herkunftsbezeichnungen weitergegeben werden.

Das Veröffentlichen von Bildern in Print- und Online-Publikationen ist nur mit vorheriger Genehmigung der Rechteinhaber erlaubt. Die systematische Speicherung von Teilen des elektronischen Angebots auf anderen Servern bedarf ebenfalls des schriftlichen Einverständnisses der Rechteinhaber.

## **Haftungsausschluss**

Alle Angaben erfolgen ohne Gewähr für Vollständigkeit oder Richtigkeit. Es wird keine Haftung übernommen für Schäden durch die Verwendung von Informationen aus diesem Online-Angebot oder durch das Fehlen von Informationen. Dies gilt auch für Inhalte Dritter, die über dieses Angebot zugänglich sind.

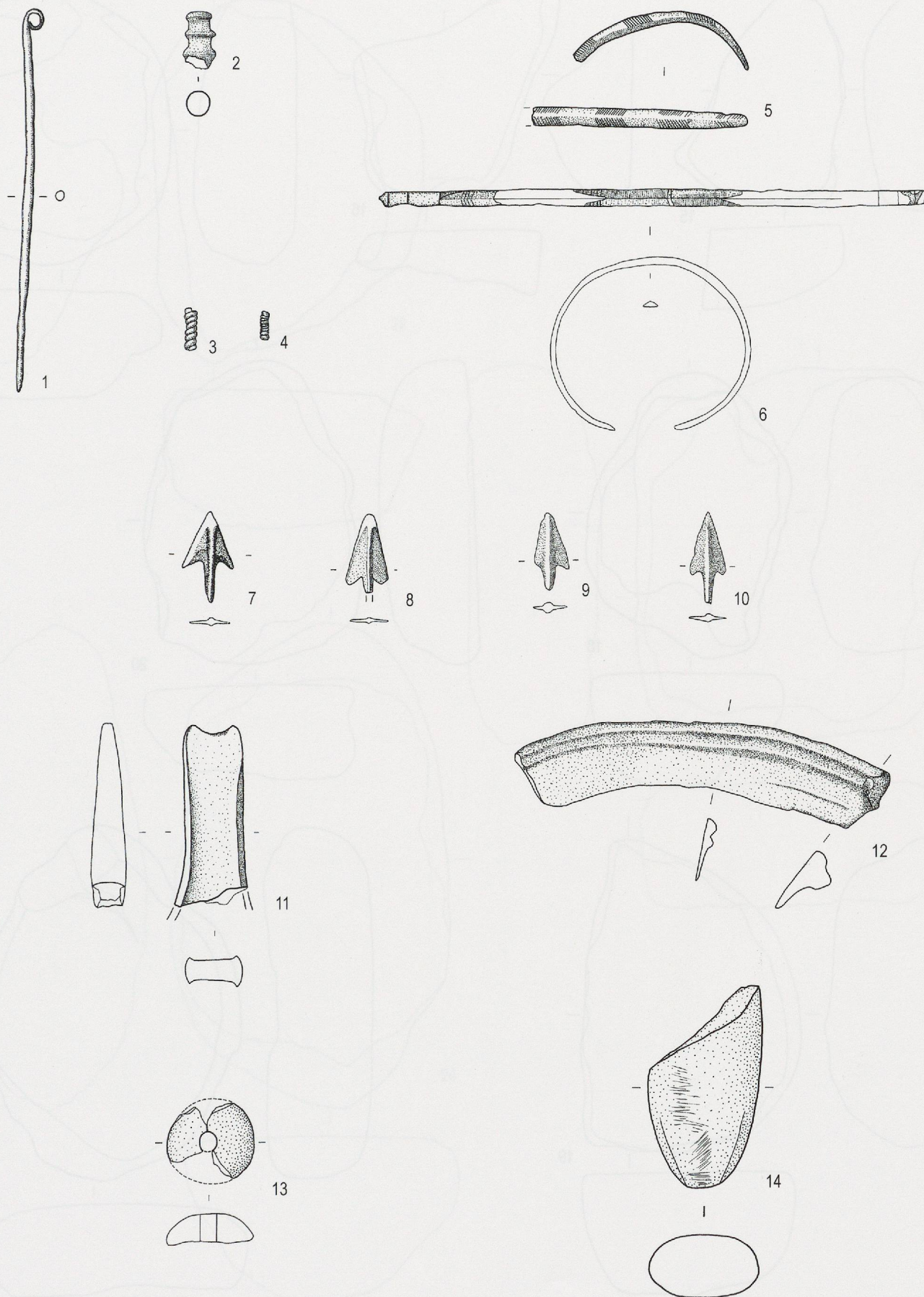

Pl. 1. Montricher VD Châtel d'Arruffens. Bronze moyen/récent. Mobilier en bronze (1-12), en céramique (13) et en pierre (14) (éch. 1:2).



Pl. 2. Montricher VD Châtel d'Arruffens. Bronze moyen/récent. Molettes à surface active plano-convexe (15-19) et convexe (20-21) (éch. 1:4).

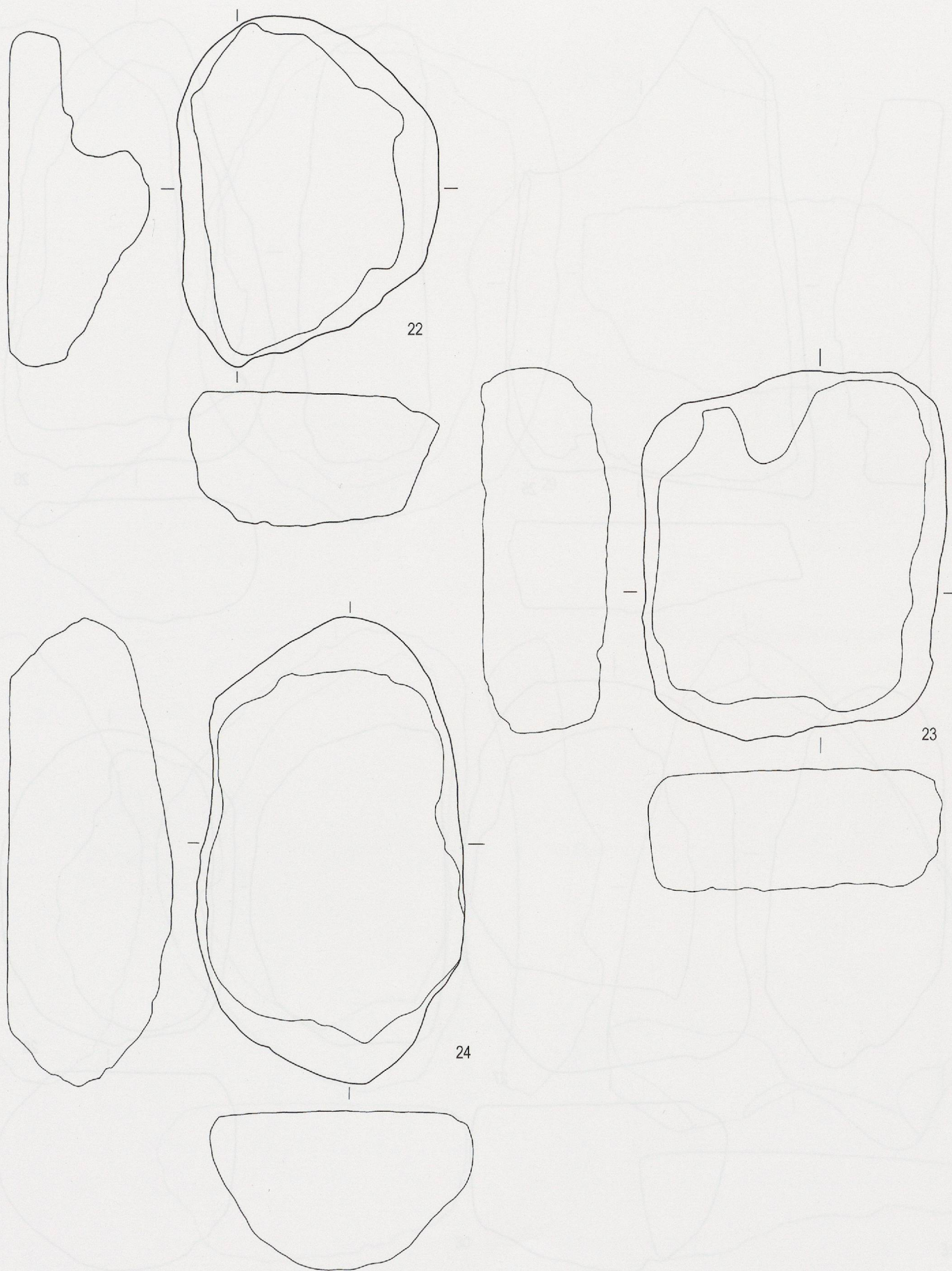

Pl. 3. Montricher VD Châtel d'Arruffens. Bronze moyen/récent. Meules à surface active plano-convexe (éch. 1:4).



Pl. 4. Montricher VD Châtel d'Arruffens. Bronze moyen/récent. Meules à surface active plano-concave (éch. 1:4).

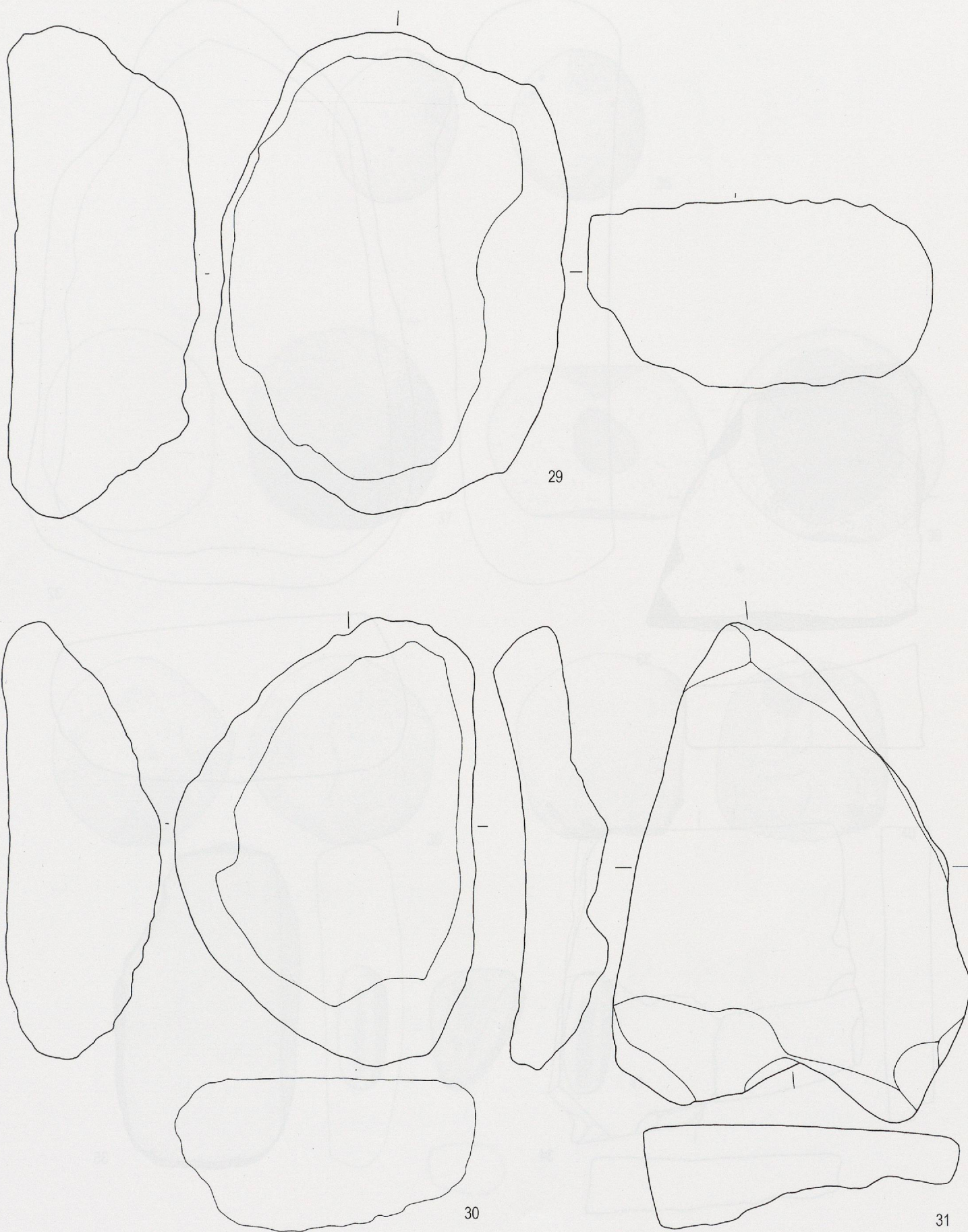

Pl. 5. Montricher VD Châtel d'Arruffens. Bronze moyen/récent. Meules à surface active plano-concave (29-30) et concave (31) (éch. 1:4).

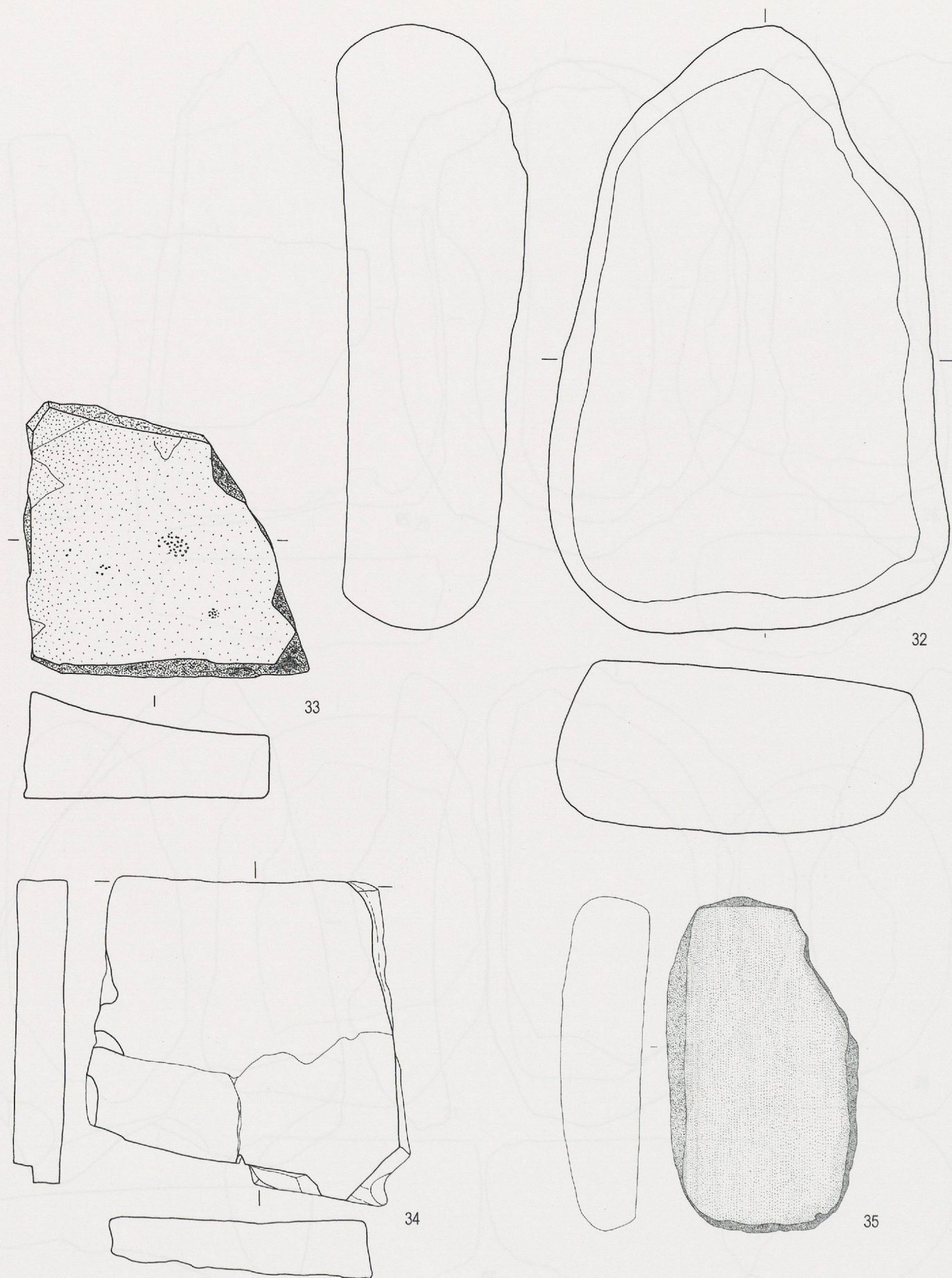

Pl. 6. Montricher VD Châtel d'Arruffens. Bronze moyen/récent ou Bas-Empire. Meule à surface active concave-convexe (32) et éléments en pierre de fonction indéterminée (éch. 1:4).

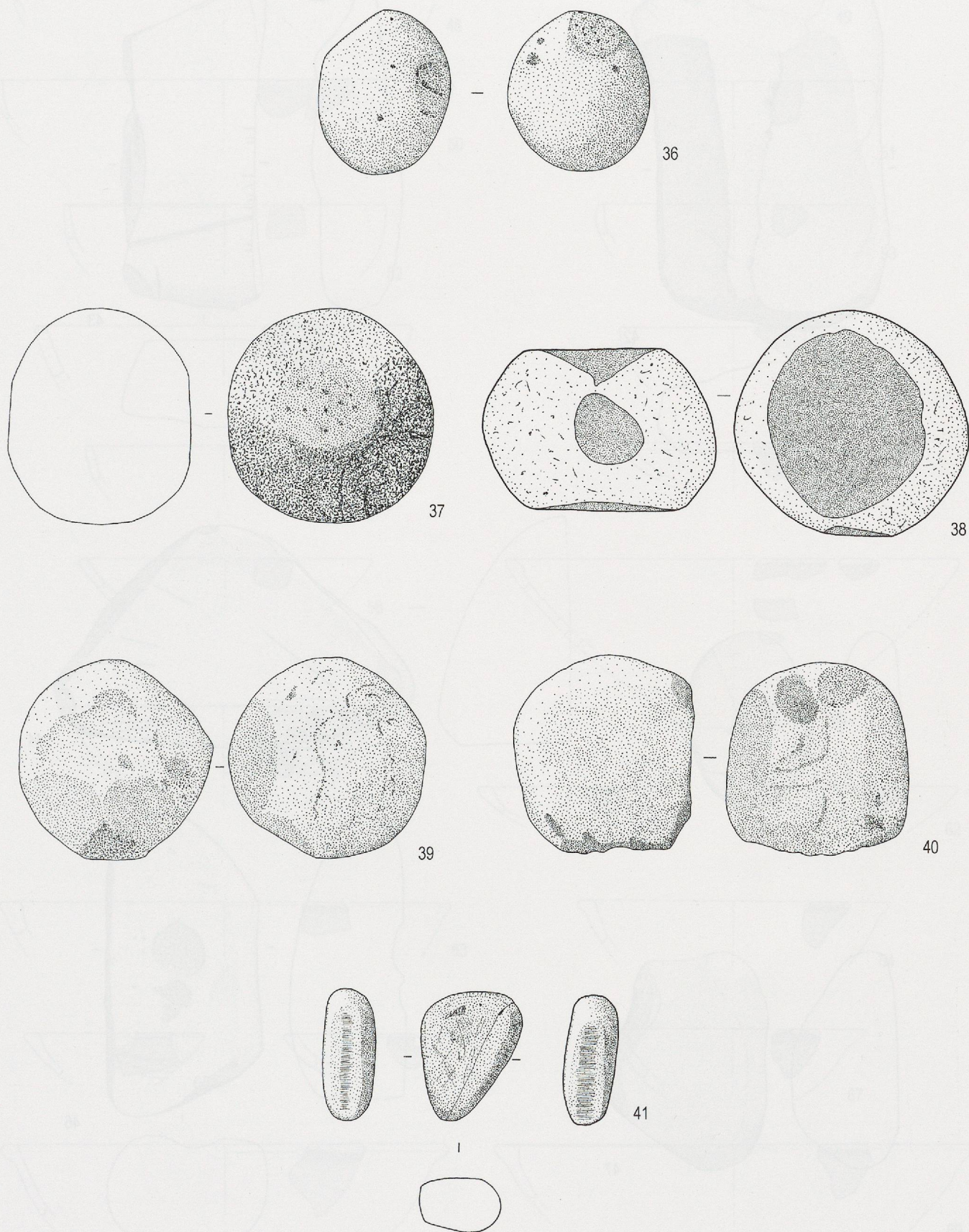

Pl. 7. Montricher VD Châtel d'Arruffens. Bronze moyen/récent ou Bas-Empire. Percuteurs et lissoir (41) (éch. 1:2).



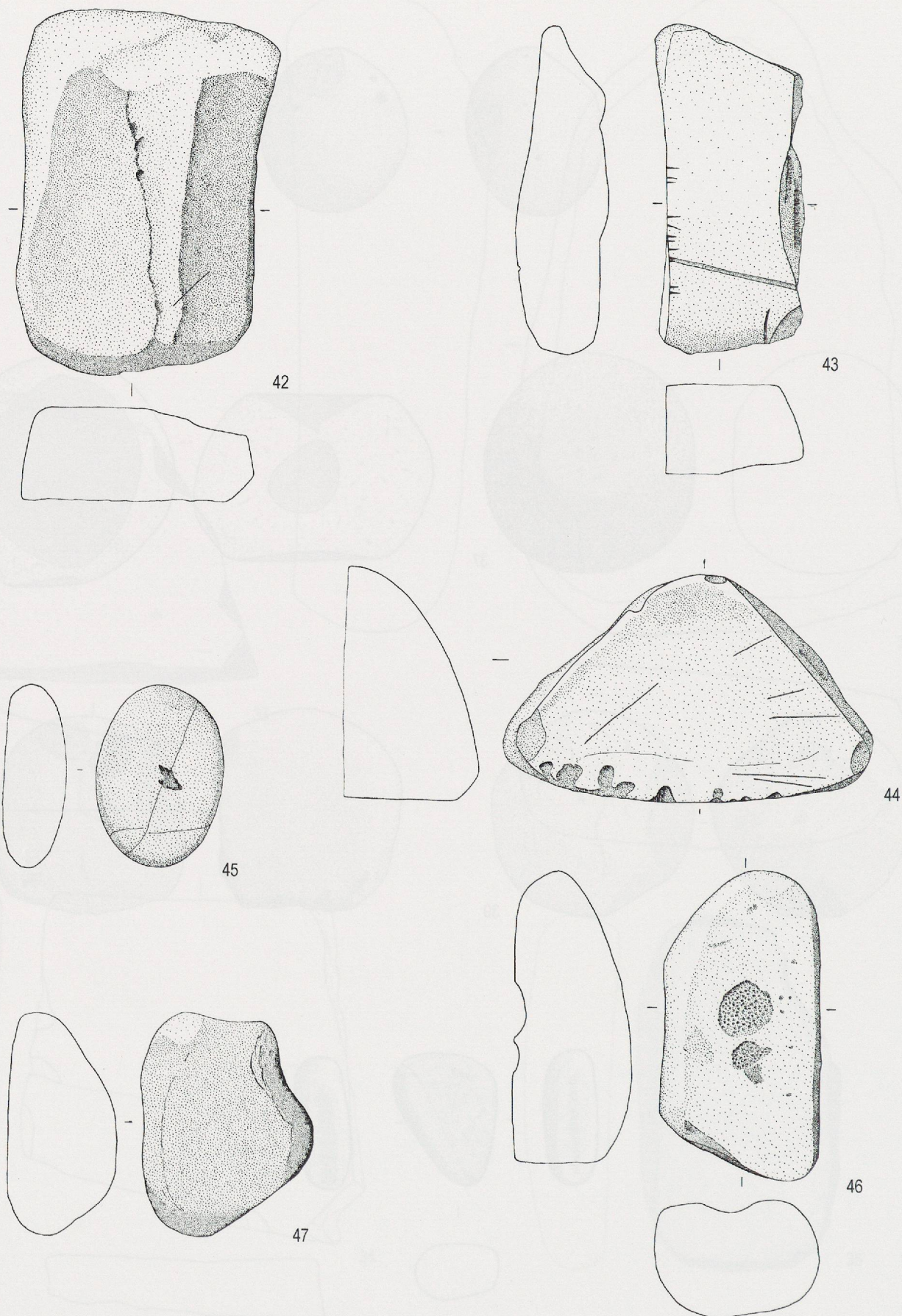

Pl. 8. Montricher VD Châtel d'Arruffens. Bronze moyen/récent ou Bas-Empire. Polissoirs/aiguiseurs (42-44), enclumes (45-46) et galet (47) (éch. 1:3).

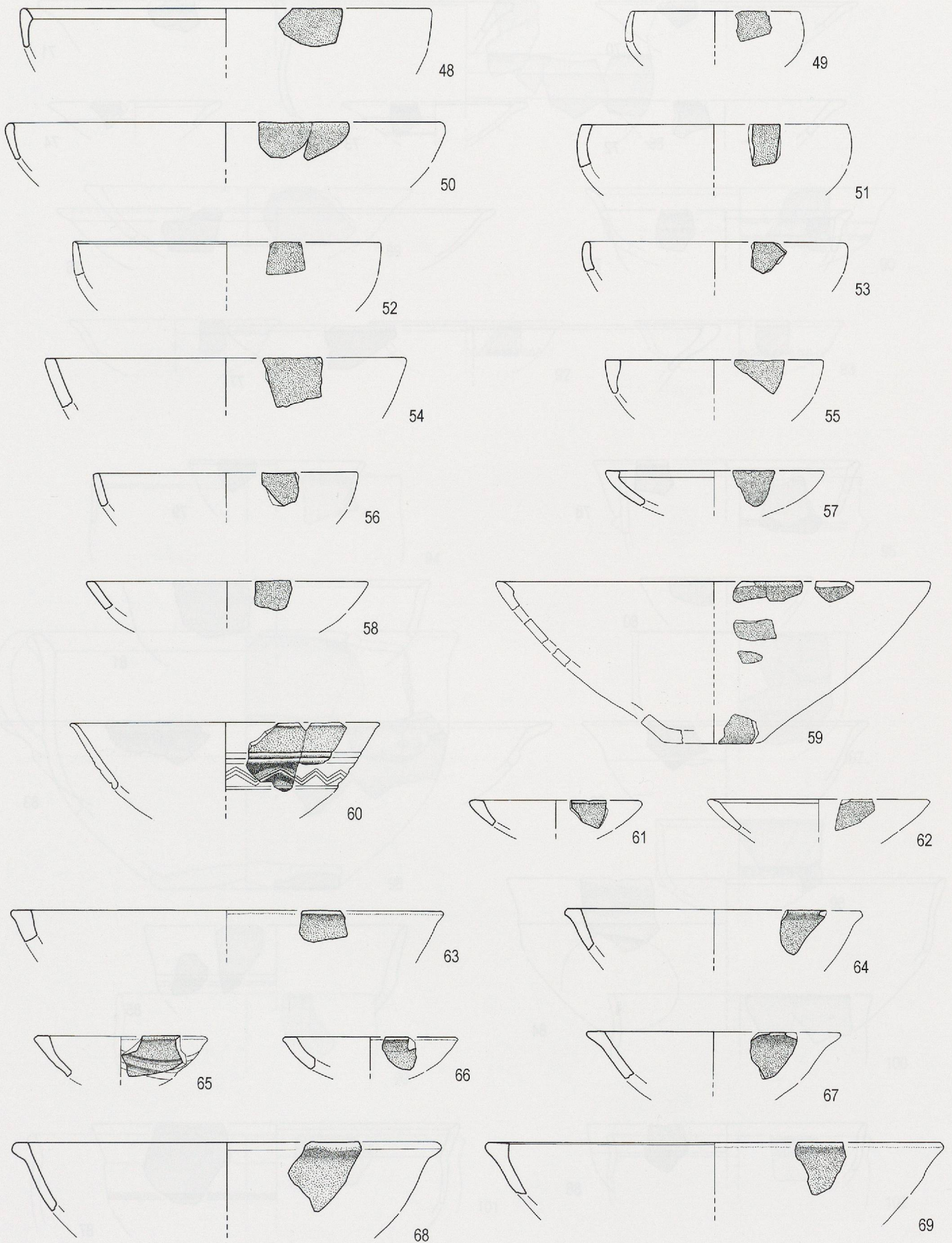

Pl. 9. Montricher VD Châtel d'Arruffens. Bronze moyen/récent. Ecuelles en céramique fine (éch. 1:3).

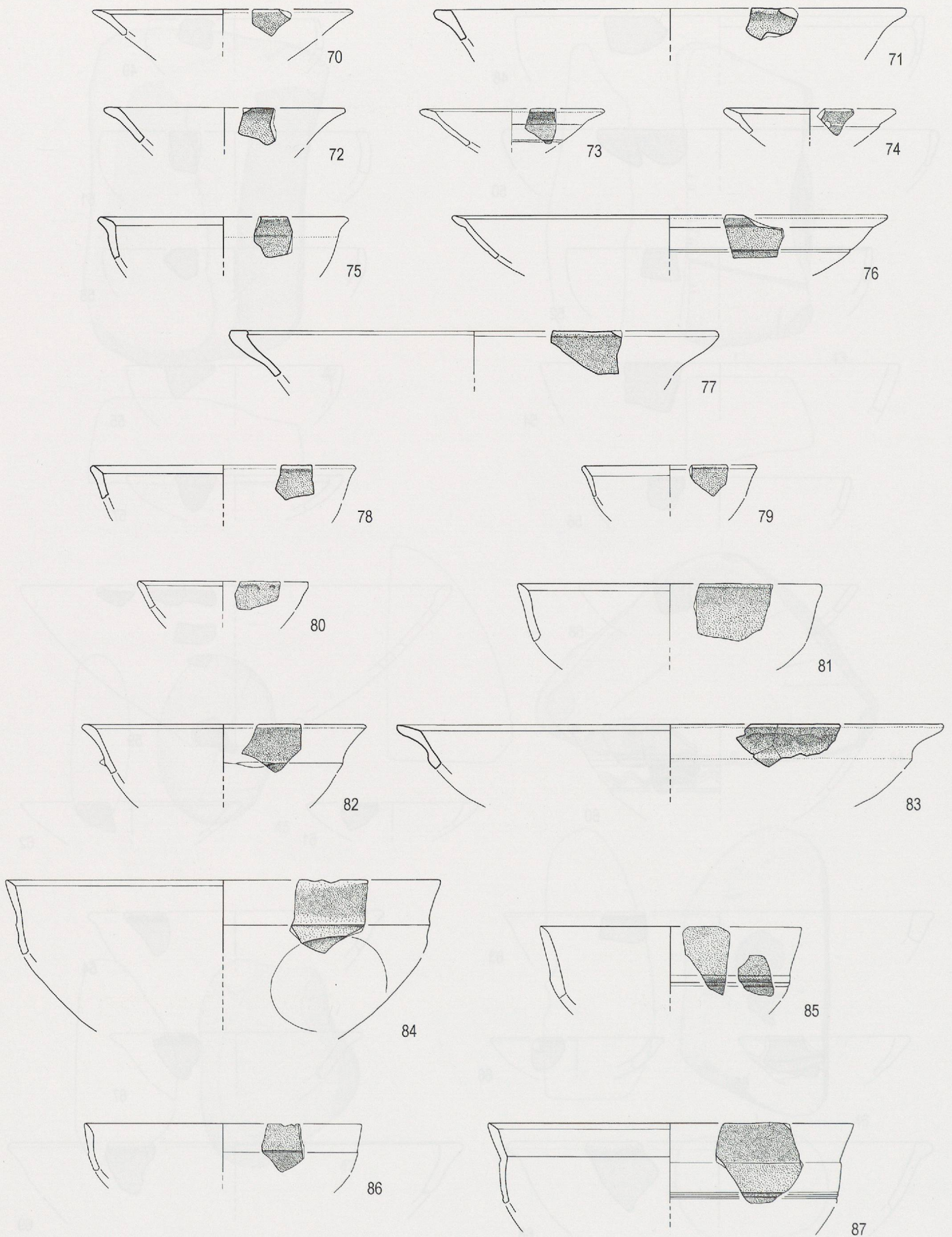

Pl. 10. Montricher VD Châtel d'Arruffens. Bronze moyen/récent. Ecuellen en céramique fine (éch. 1:3).

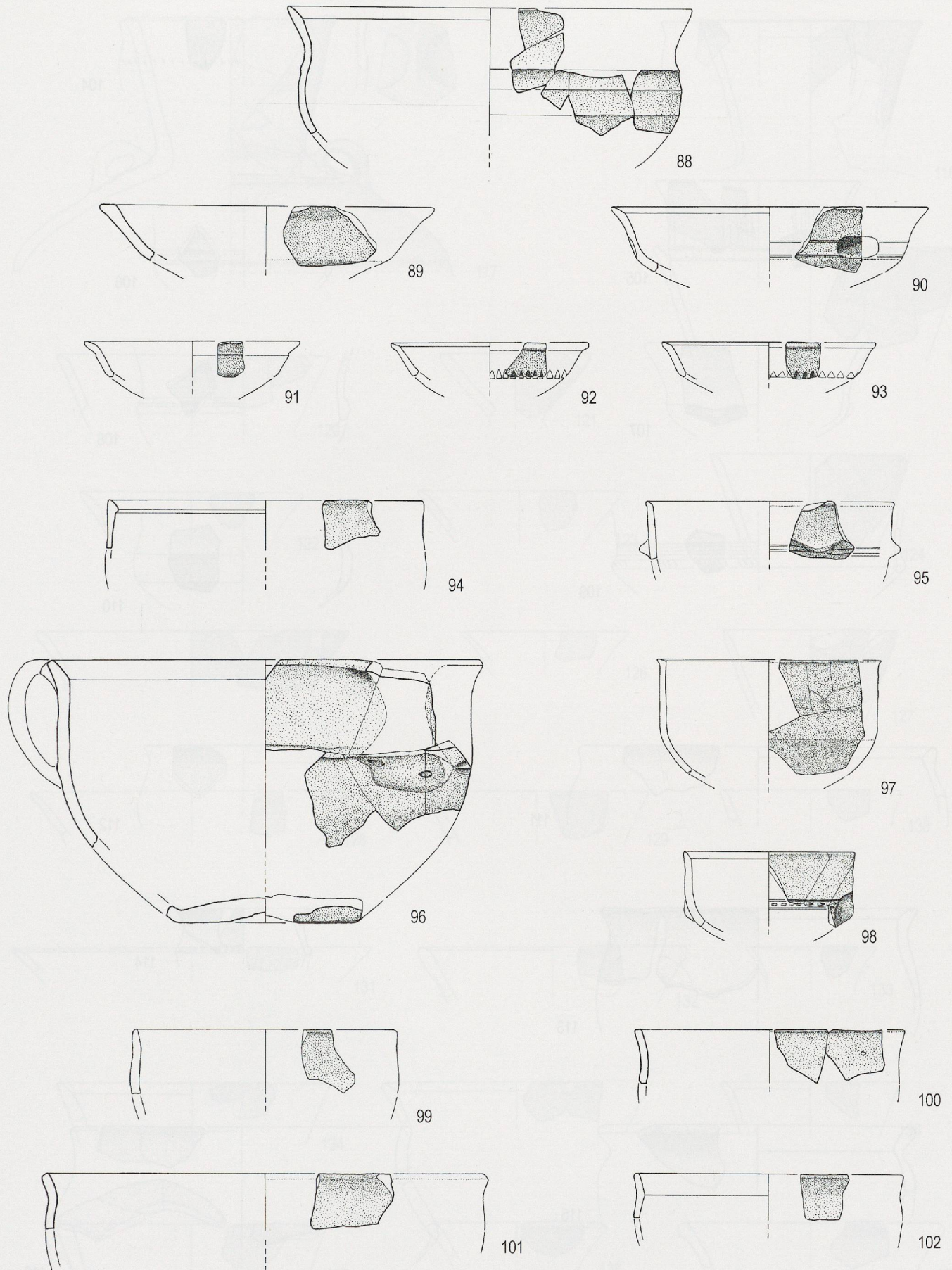

Pl. 11. Montricher VD Châtel d'Arruffens. Bronze moyen/récent. Ecuellen (88-93) et tasses ou bols (94-102) en céramique fine (éch. 1:3).

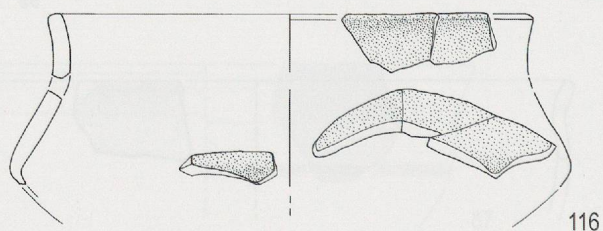
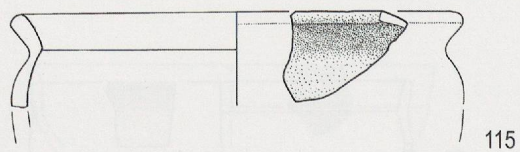
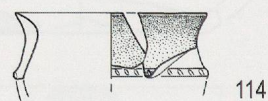
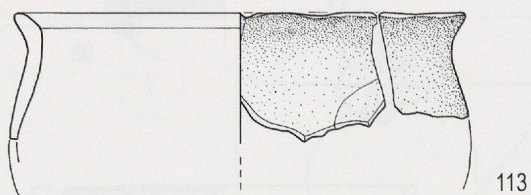
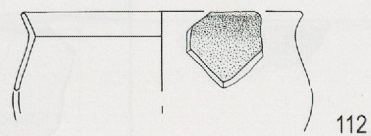
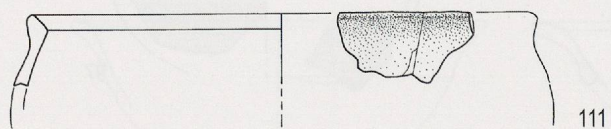
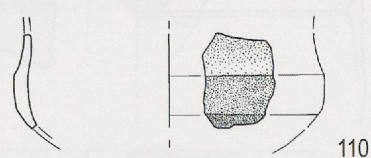
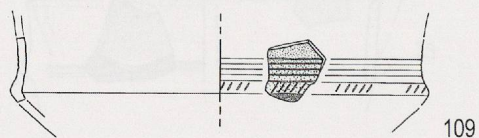
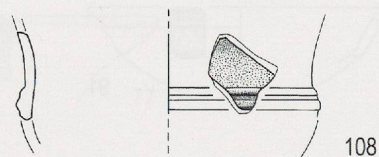
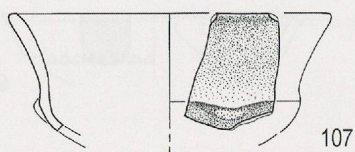
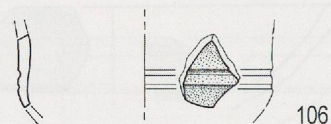
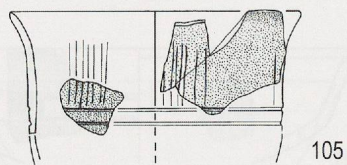
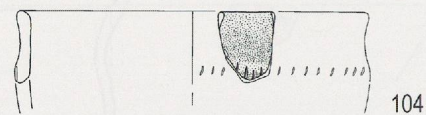
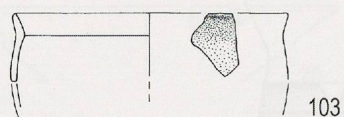

BPl. 12. Montricher VD Châtel d'Arruffens. Bronze moyen/récent. Bols ou tasses (103-104), gobelets (105-110) et petits plats creux (111-116) en céramique fine (éch. 1:3).

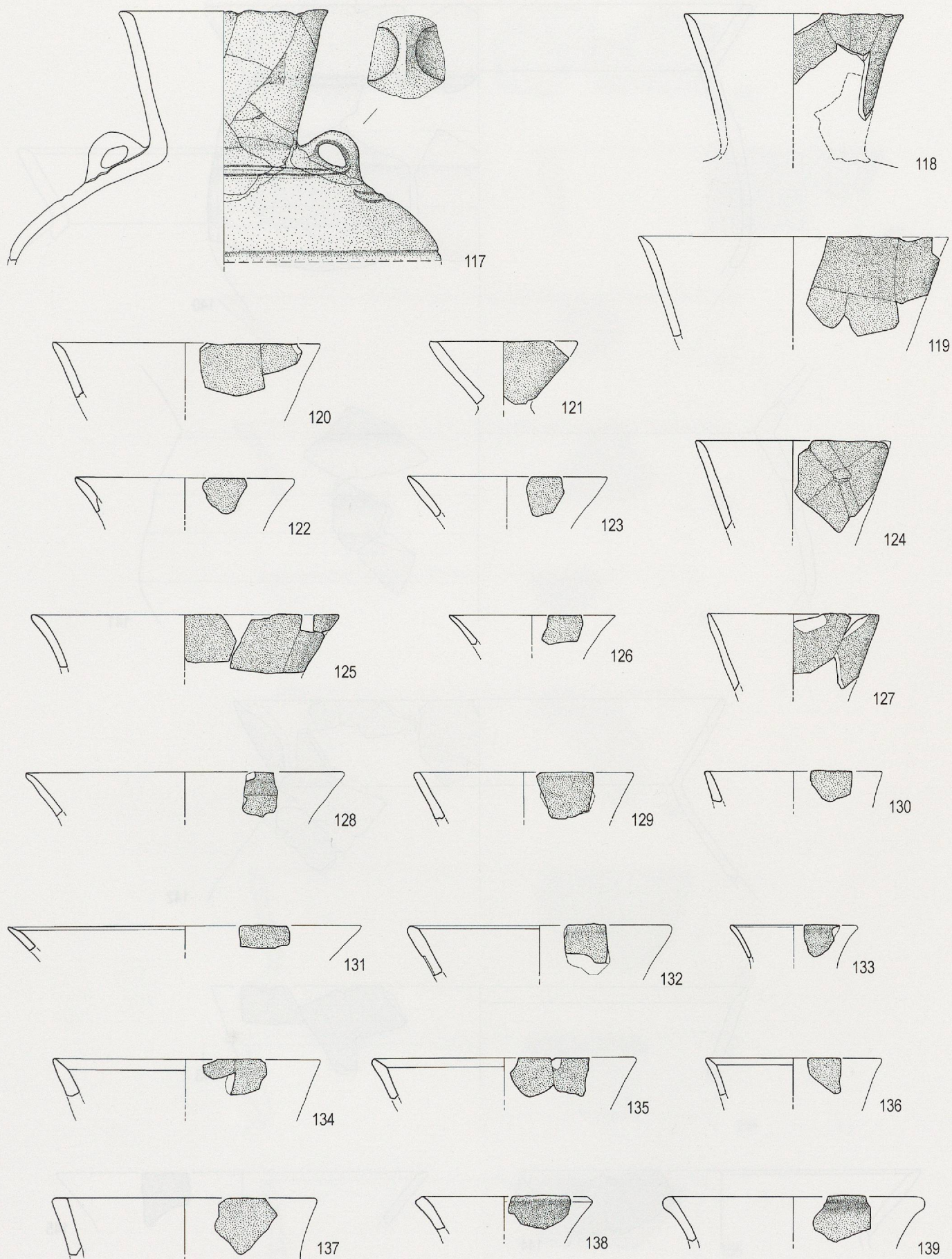

Pl. 13. Montricher VD Châtel d'Arruffens. Bronze moyen/récent. Pots à col évasé étroit (cruches ou amphores) en céramique fine (éch. 1:3).

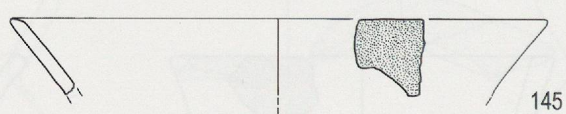
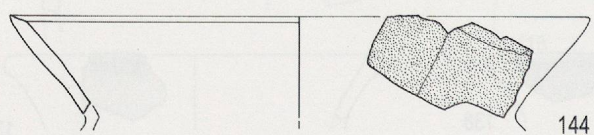
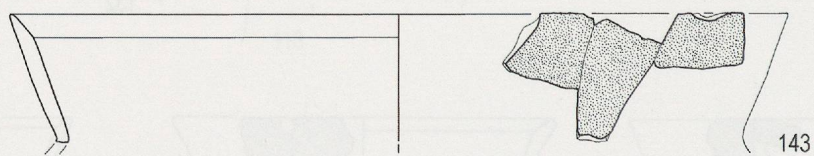
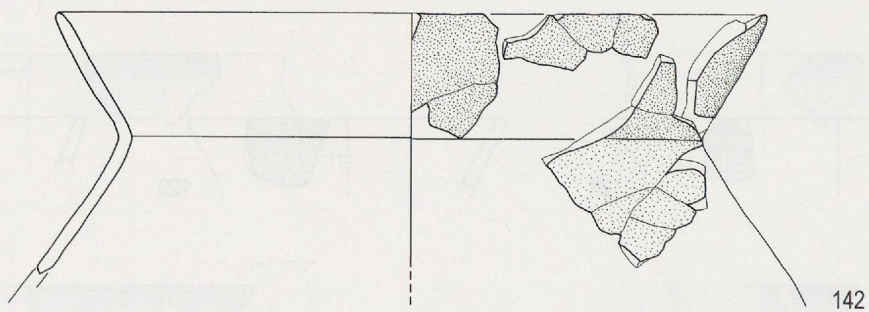
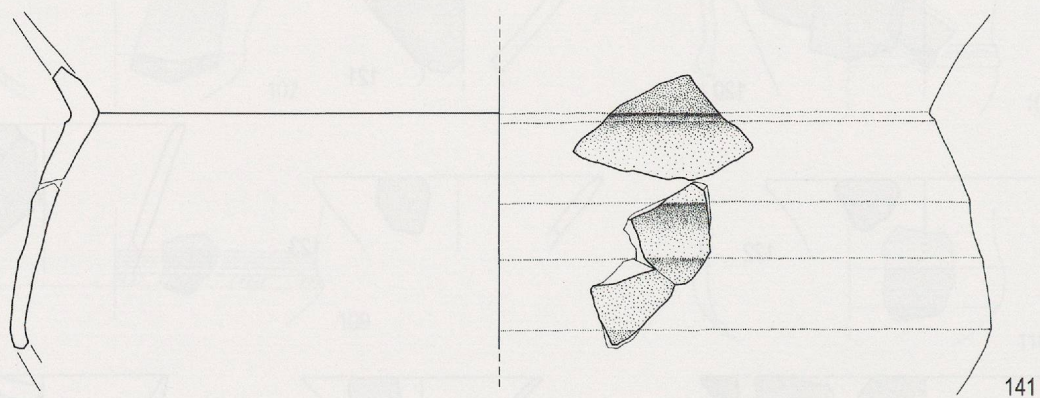
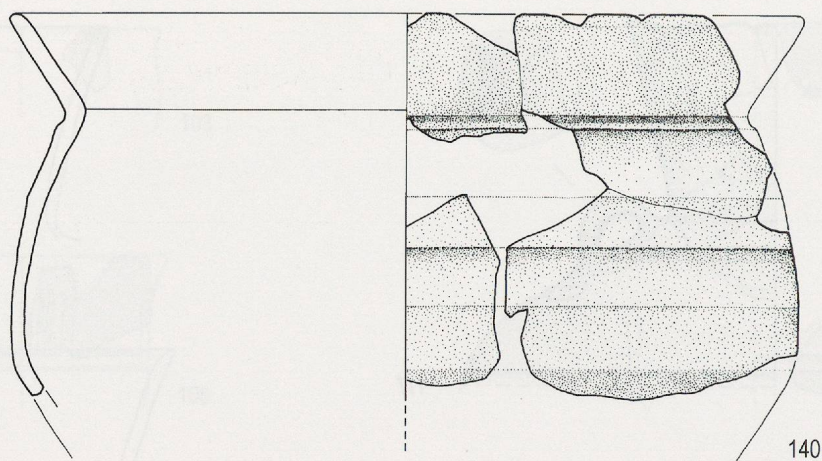

Pl. 14. Montricher VD Châtel d'Arruffens. Bronze moyen/récent. Pots à col évasé large (cruches ou amphores) en céramique fine (éch. 1:3).

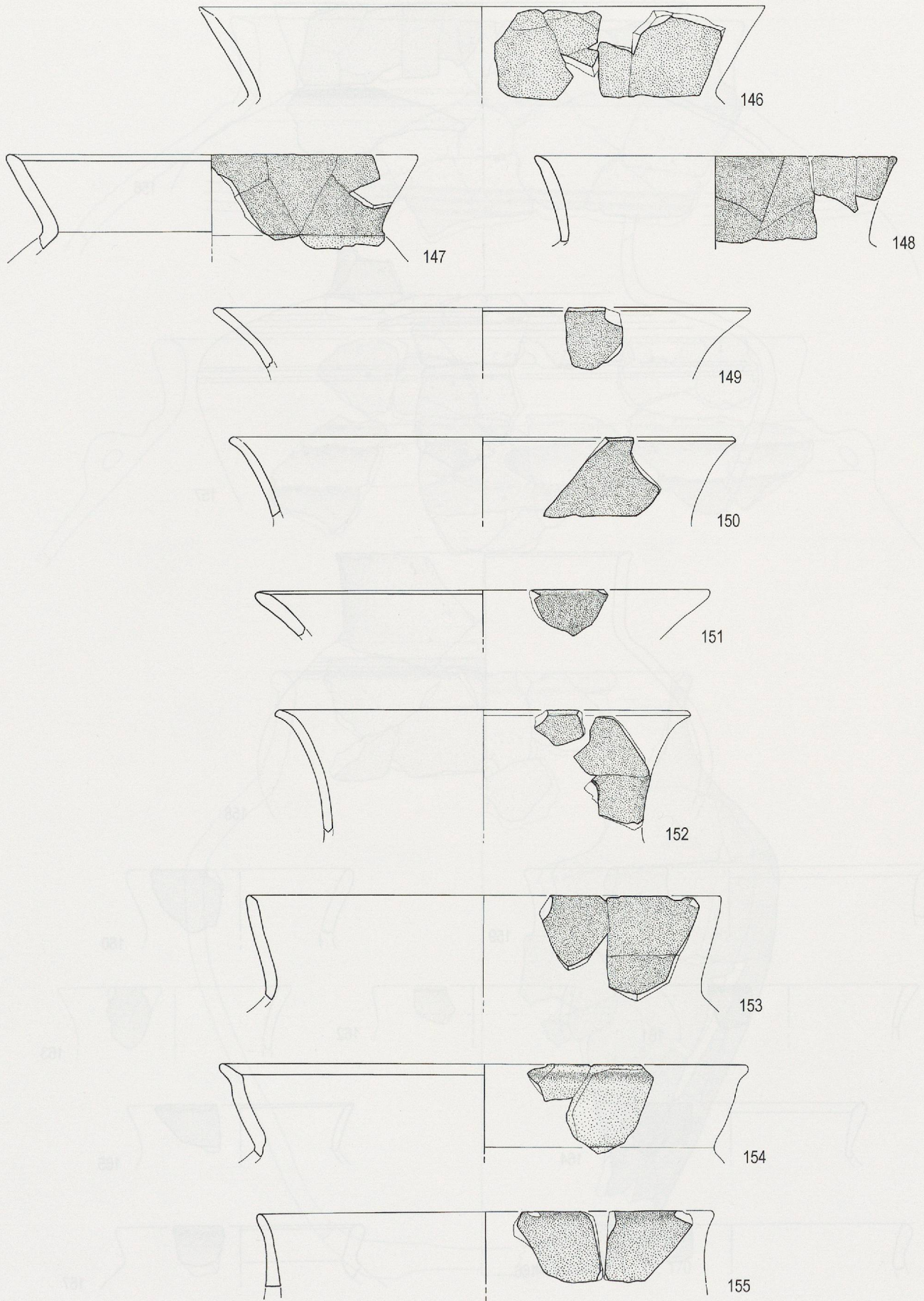

Pl. 15. Montricher VD Châtel d'Arruffens. Bronze moyen/récent. Pots à col évasé large (cruches ou amphores) en céramique fine (éch. 1:3).



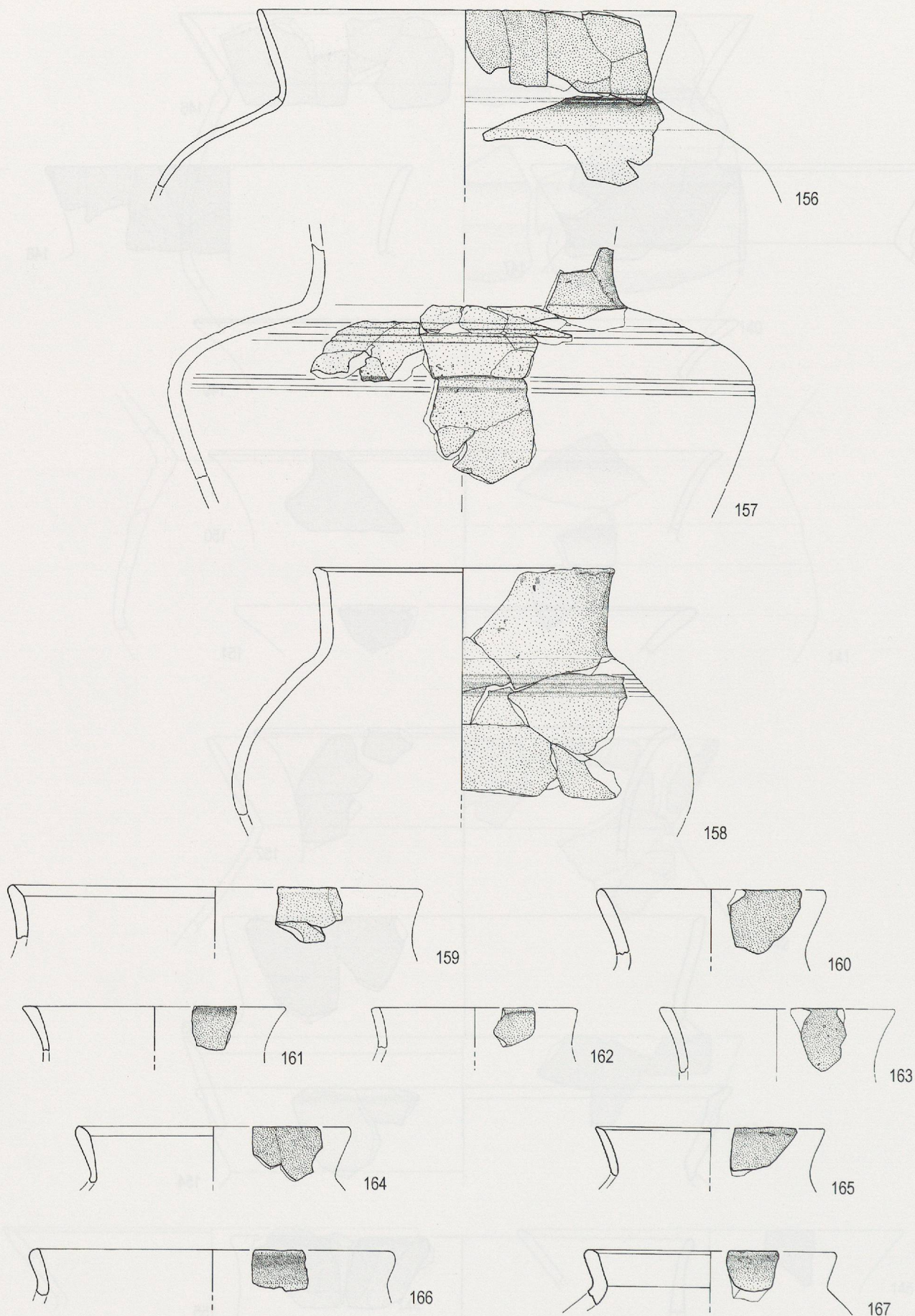

Pl. 16. Montricher VD Châtel d'Arruffens. Bronze moyen/récent. Pots à col évasé large (156) et étroit (cruche?) (157-158) et cols évasés divers (159-167) en céramique fine (éch. 1:3).

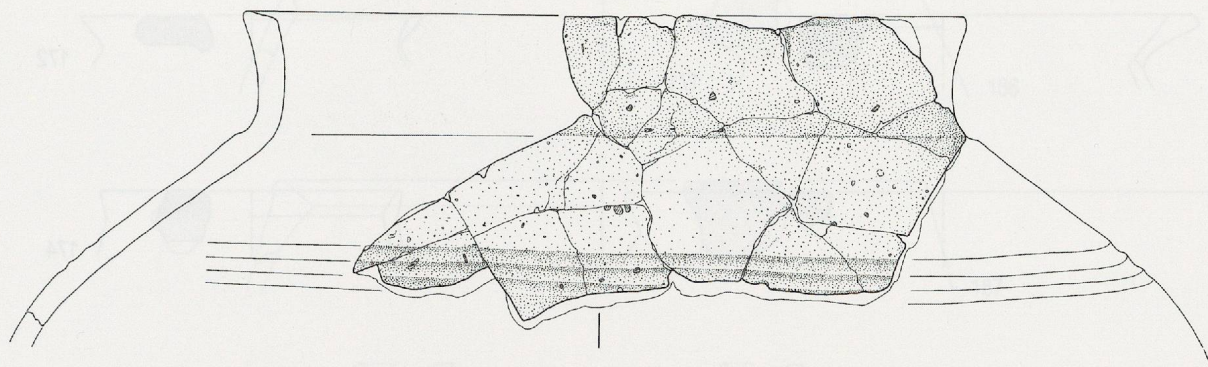

168

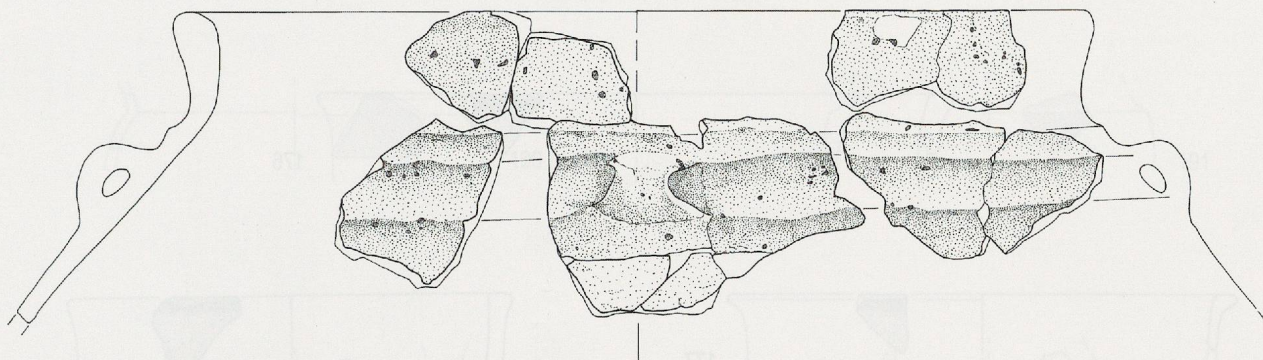

169

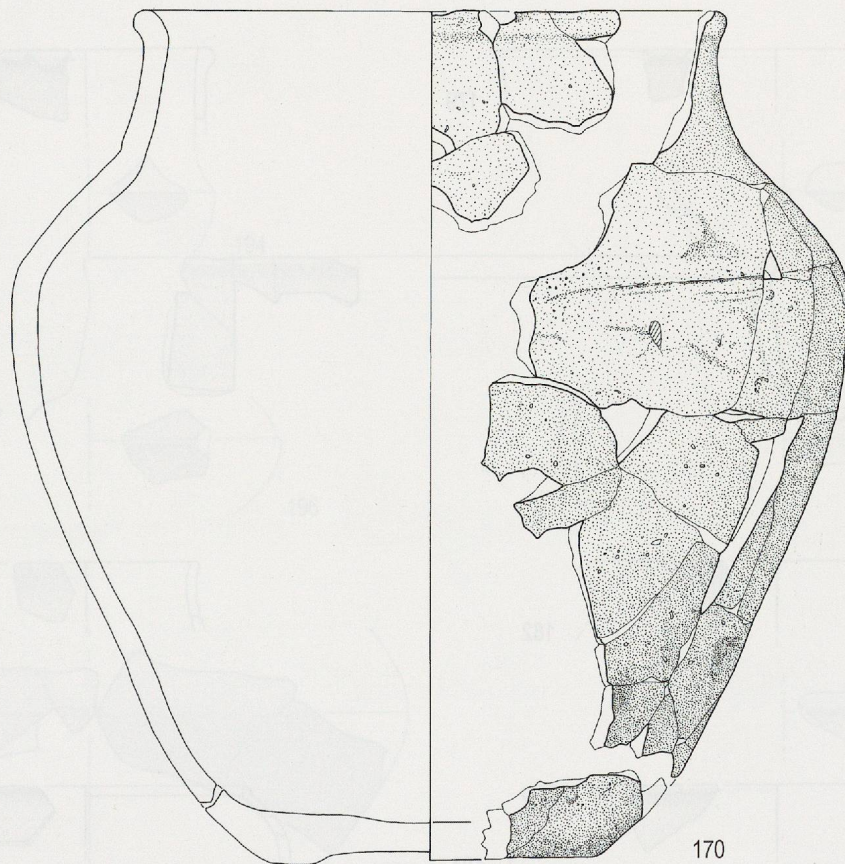

170

Pl. 17. Montricher VD Châtel d'Arruffens. Bronze moyen/récent. Pots en céramique fine (éch. 1:3).

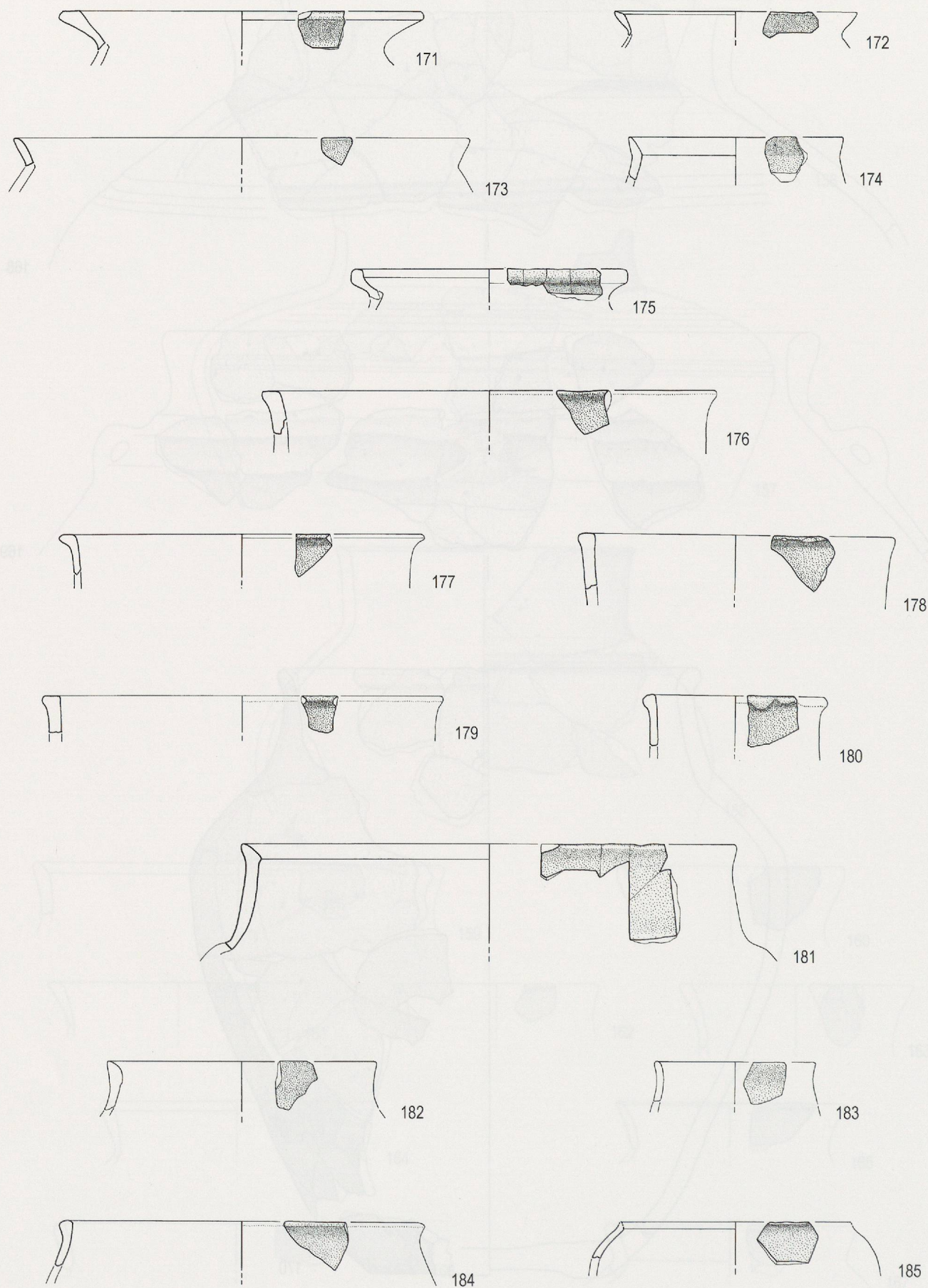

Pl. 18. Montricher VD Châtel d'Arruffens. Bronze moyen/récent. Cols évasés divers (171-175), cols cylindriques (176-183) et corps à épaule rentrante sans encolure (184-185) en céramique fine (éch. 1:3).

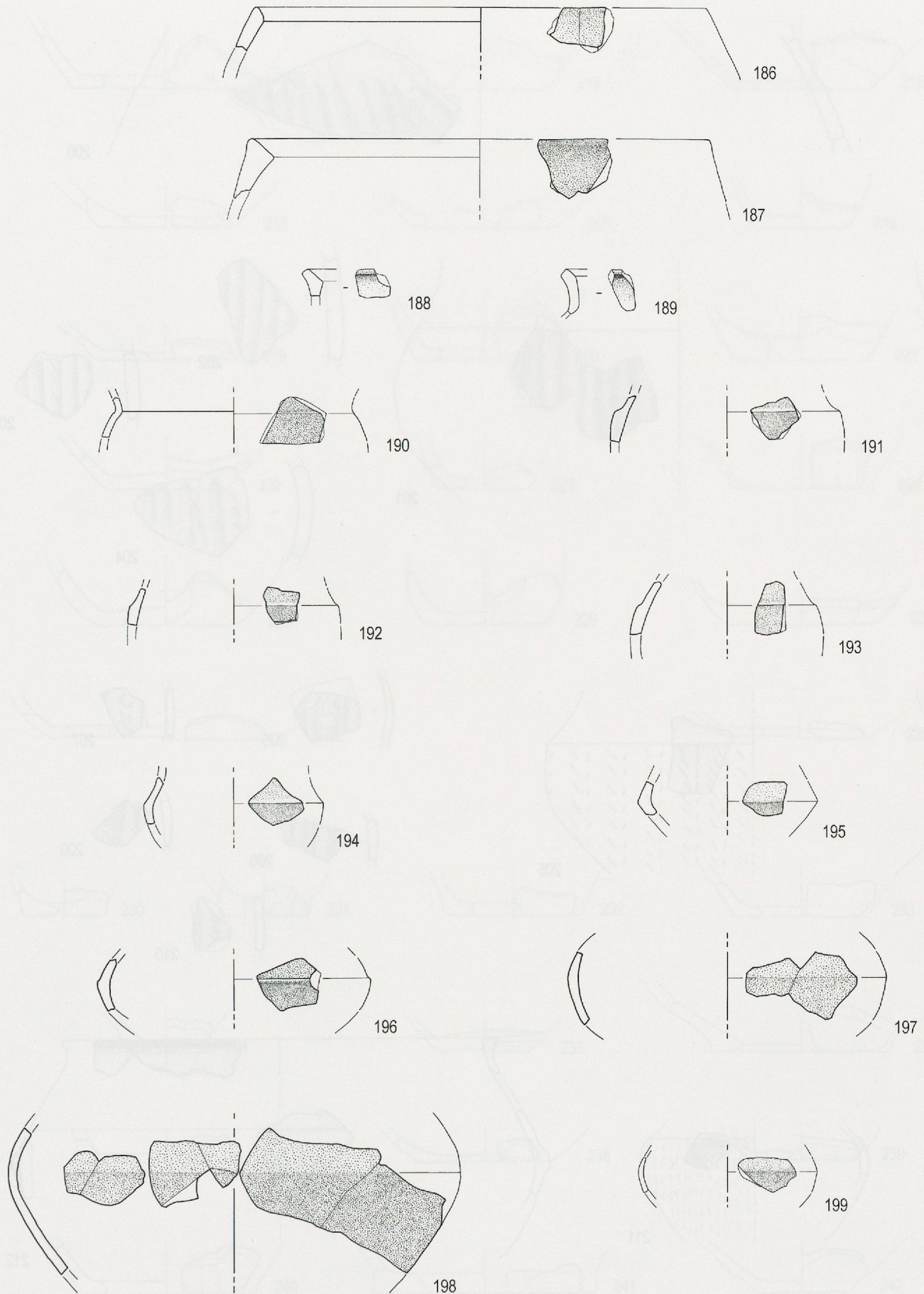

Pl. 19. Montricher VD Châtel d'Arruffens. Bronze moyen/récent. Corps à épaule rentrante sans encolure (186-187), lèvres segmentées (188-189), ressauts corps/col (190-194), corps biconiques (195-199) en céramique fine (éch. 1:3).

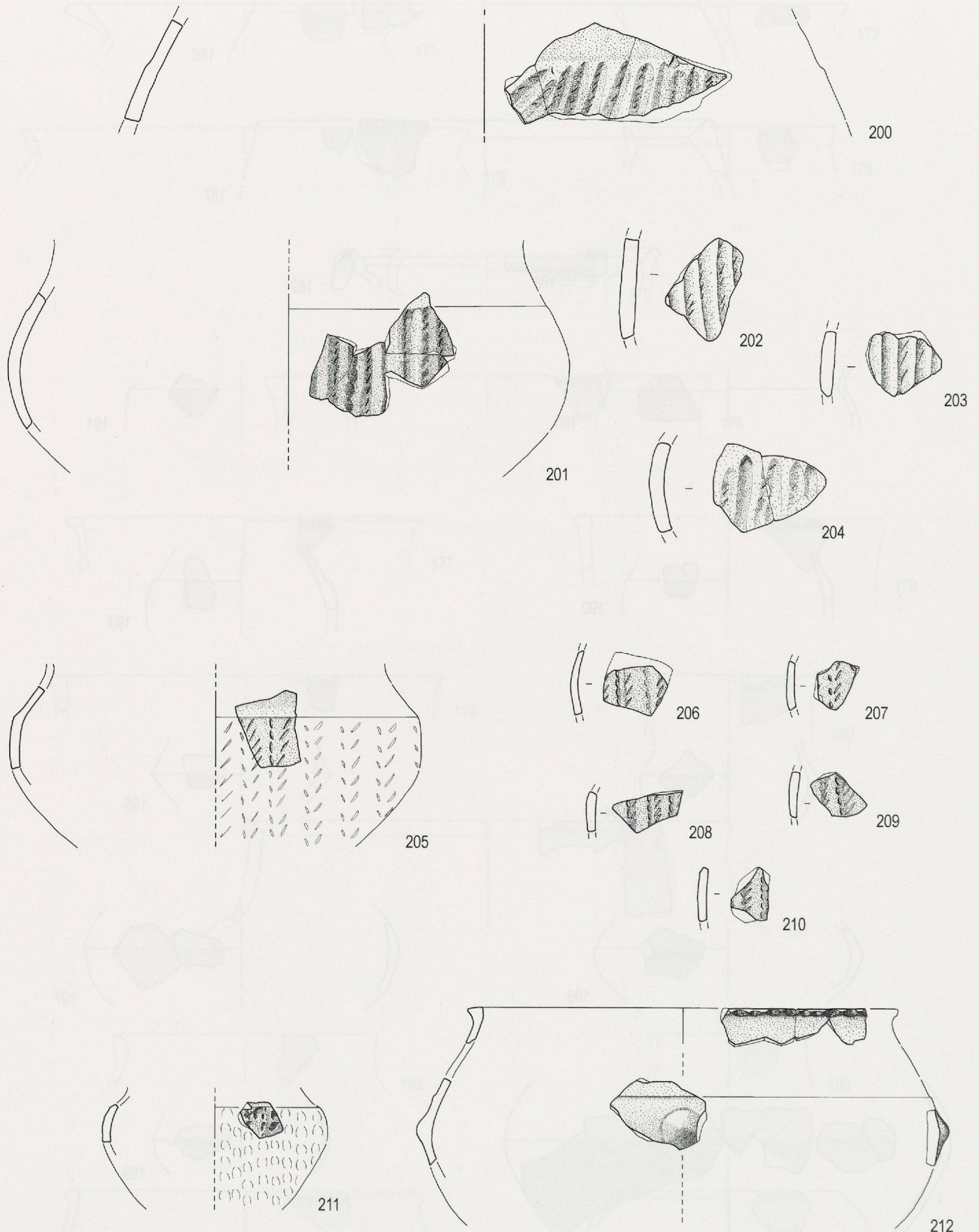

Pl. 20. Montricher VD Châtel d'Arruffens. Bronze moyen/récent. Plats creux (201, 205, 211-212) et décors couvrants à la roulette en céramique fine (éch. 1:3).

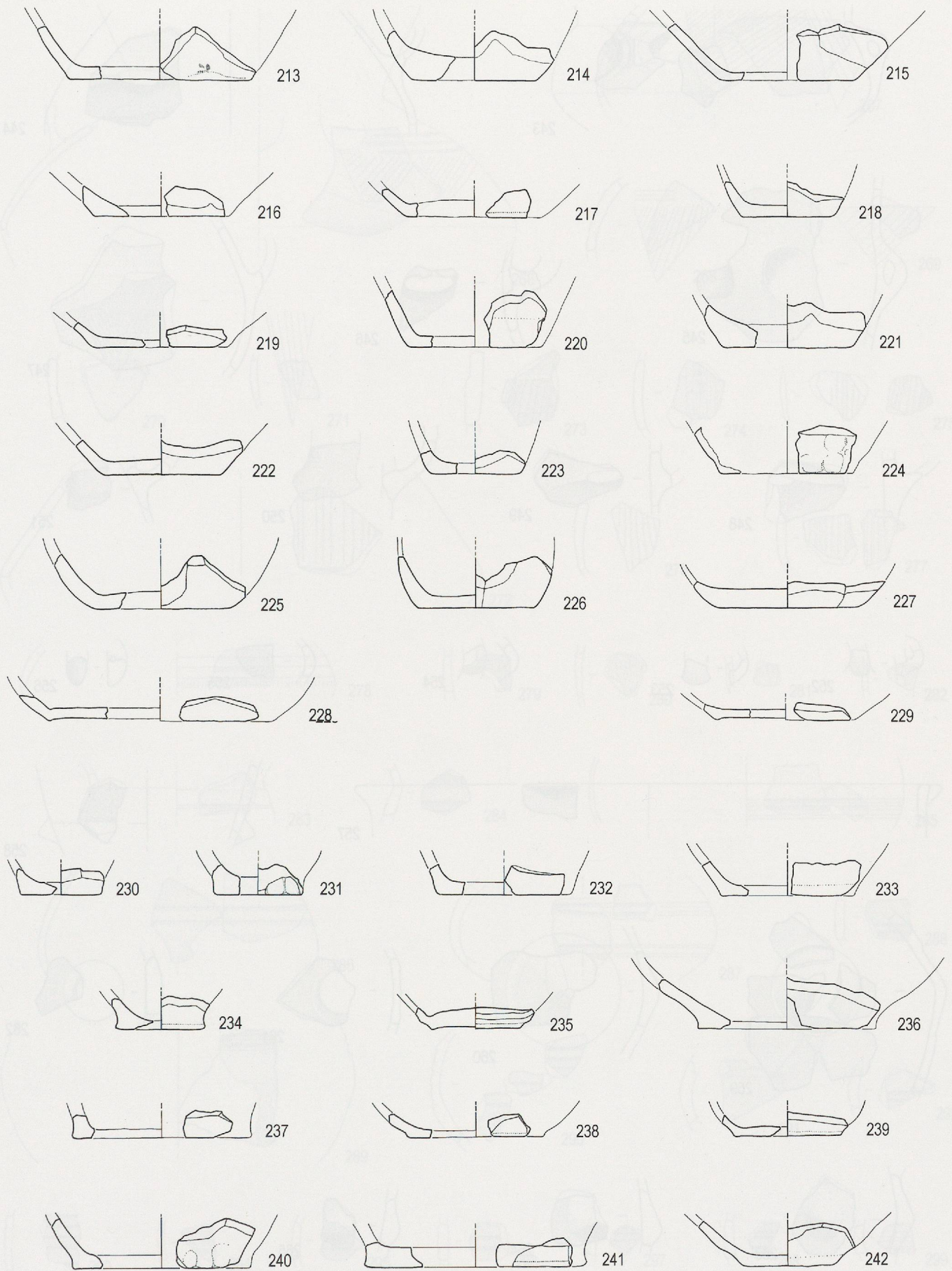

Pl. 21. Montricher VD Châtel d'Arruffens. Bronze moyen/récent. Bases plates (213-229) et plates à amorce de pied (230-242) en céramique fine (éch. 1:3).

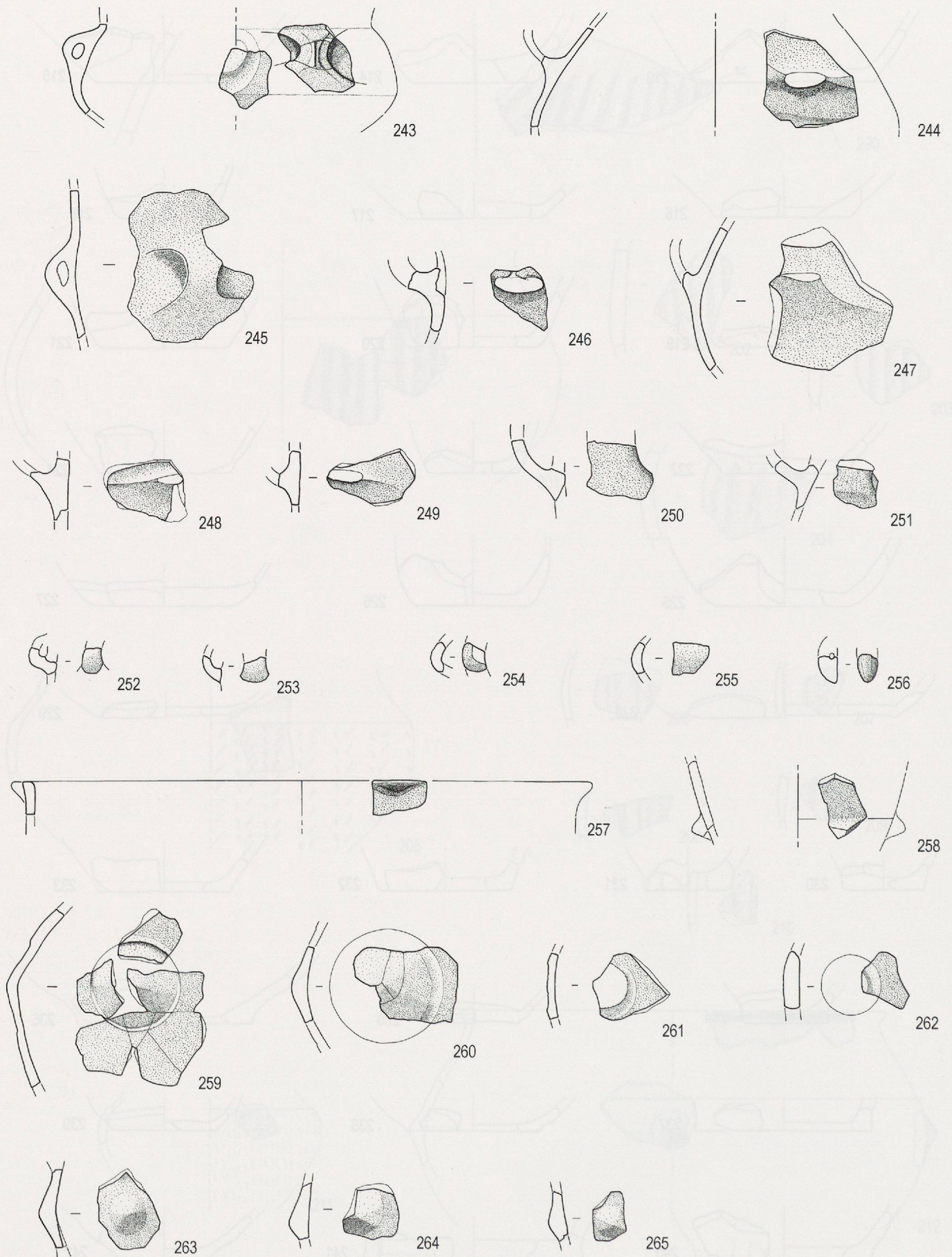

Pl. 22. Montrichier VD Châtel d'Arruffens. Bronze moyen/récent. Anses (243-256), languettes (257-258) et mamelons (259-265) en céramique fine (éch. 1:3).

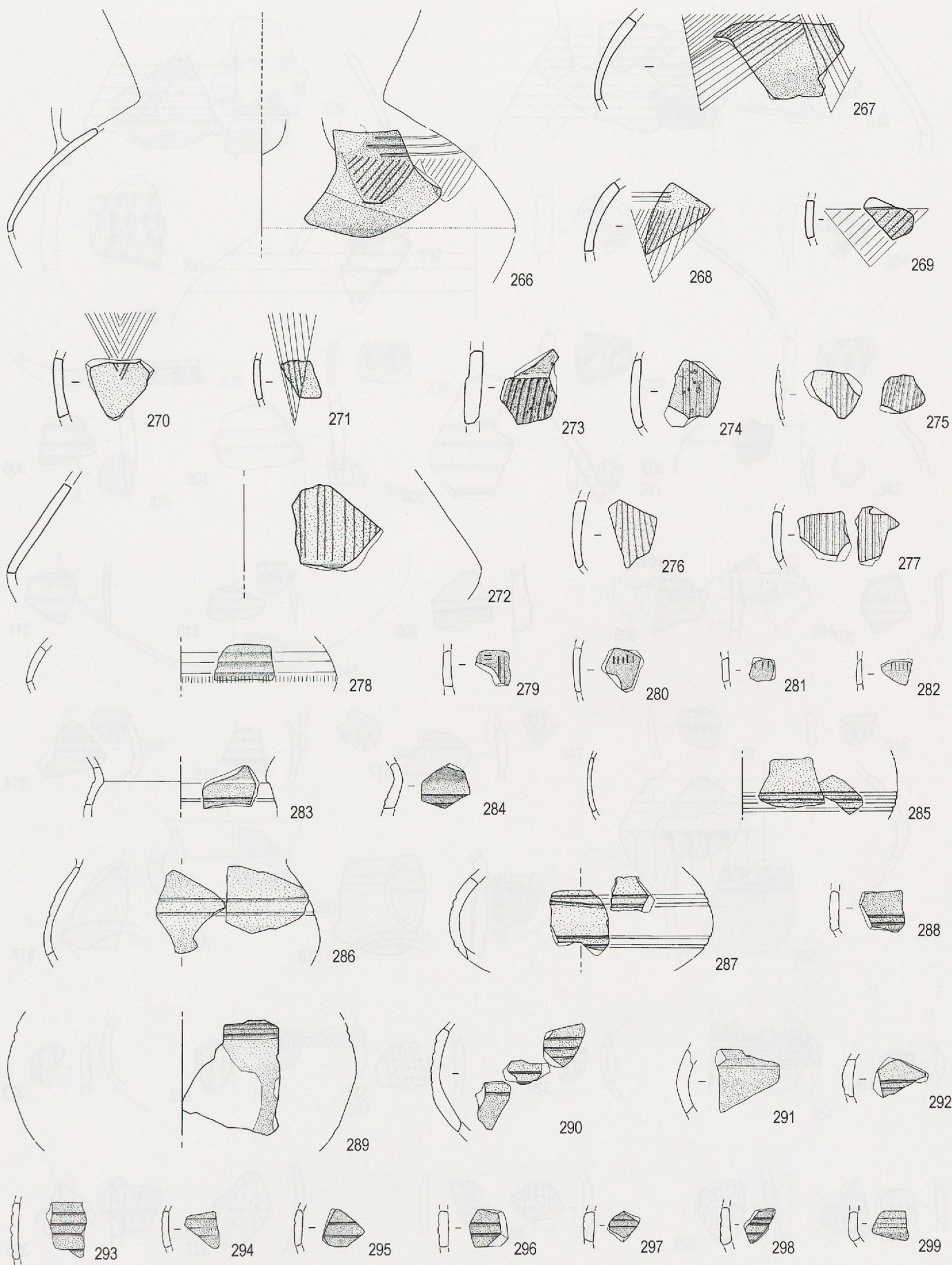

Pl. 23. Montricher VD Châtel d'Arruffens. Bronze moyen/récent. Triangles (266-271), incisions couvrantes (272), surfaces peignées (275-277), lignes d'encoches (278-282) et rainures (283-299) en céramique fine et grossière (273-274) (éch. 1:3).



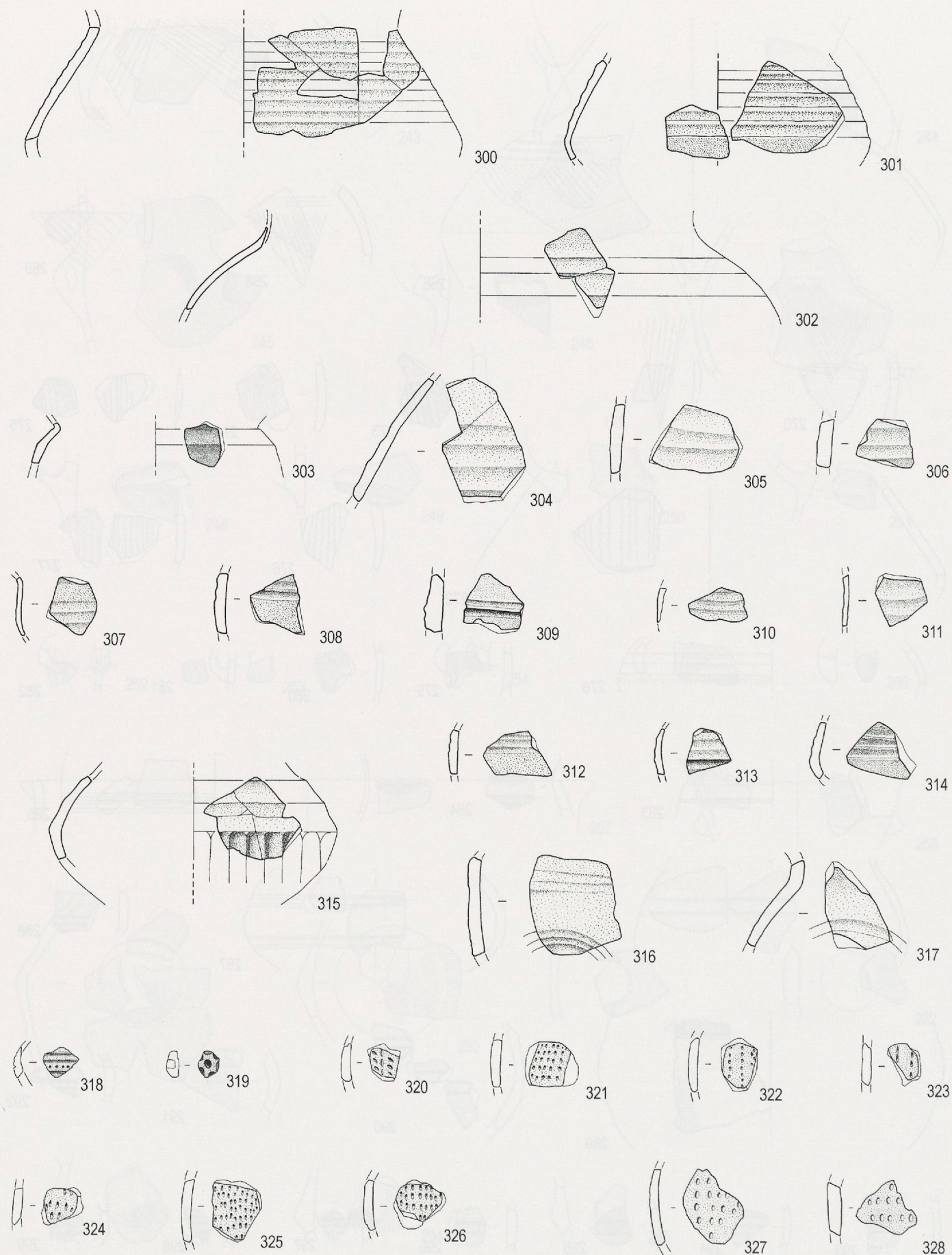

Pl. 24. Montricher VD Châtel d'Arruffens. Bronze moyen/récent. Cannelures (300-317), décors de coups de poinçon (318-319) et couvrants à la roulette (320-328) en céramique fine (éch. 1:3).

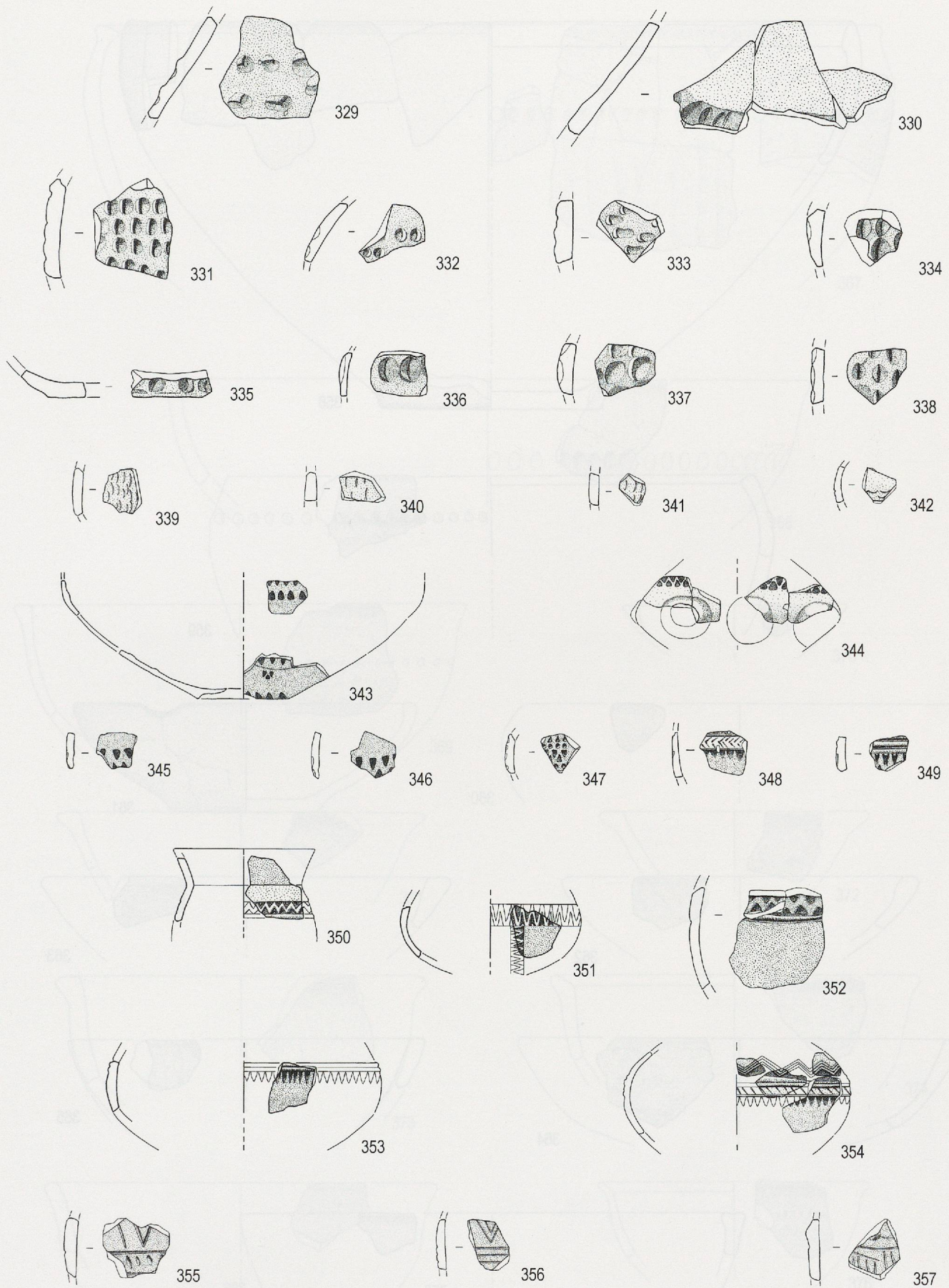

Pl. 25. Montricher VD Châtel d'Arruffens. Bronze moyen/récant. Impressions digitales couvrantes (329-338), coups d'ongle couvrants (339-342), décors estampés, excisés et complexes (343-357) en céramique fine (éch. 1:3).

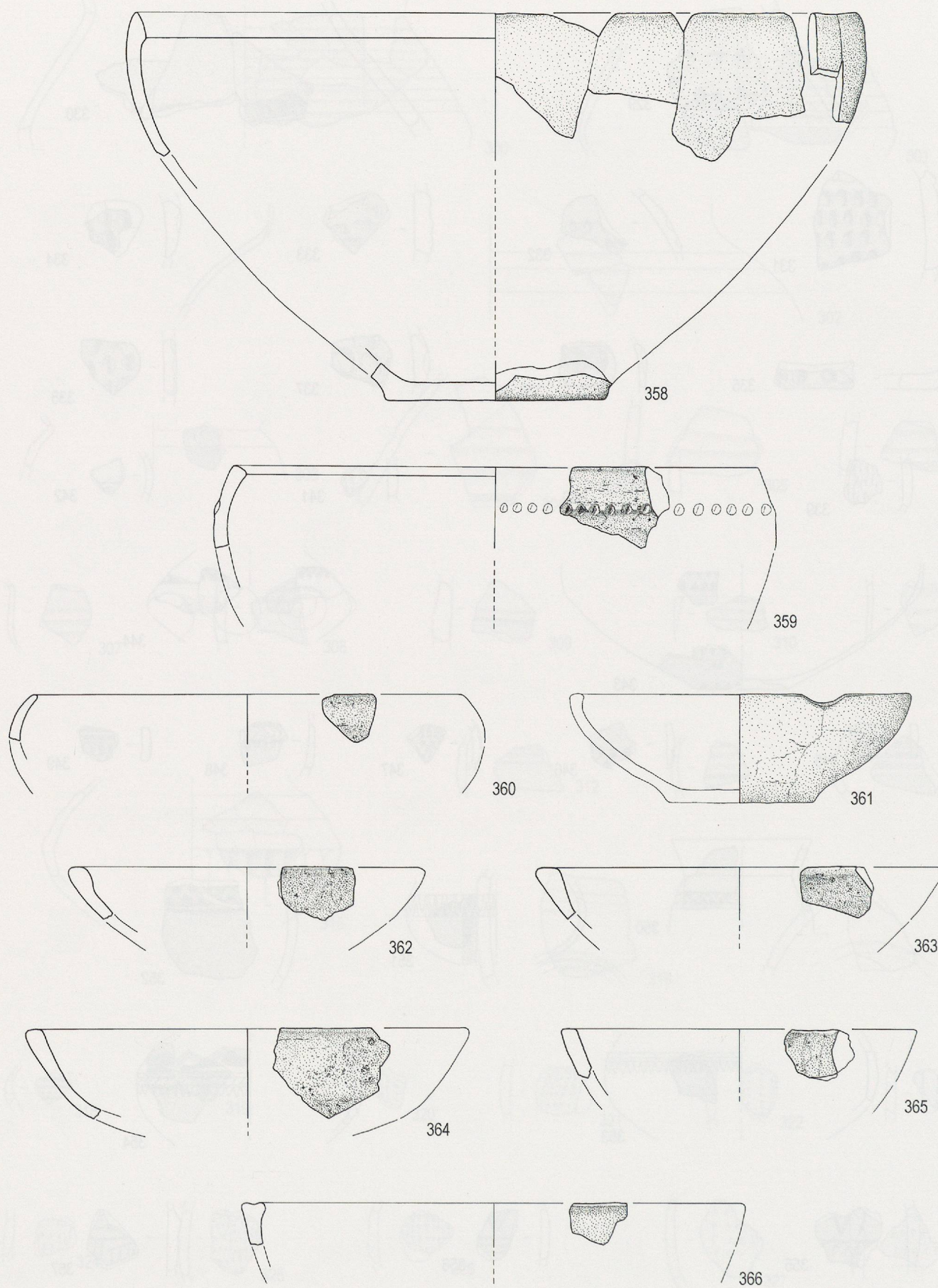

Pl. 26. Montricher VD Châtel d'Arruffens. Bronze moyen/récent. Ecuellen en céramique grossière (éch. 1:3).

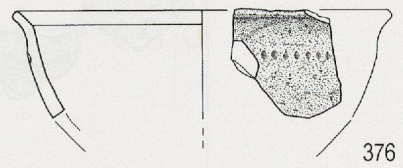
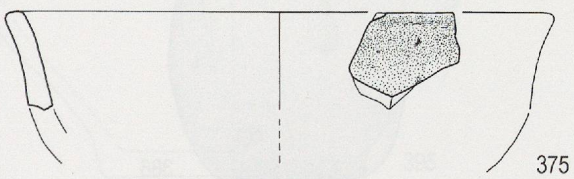
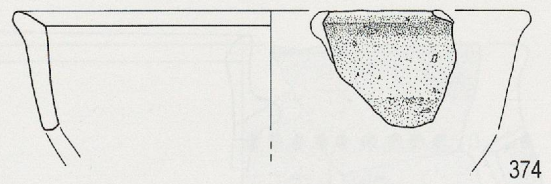
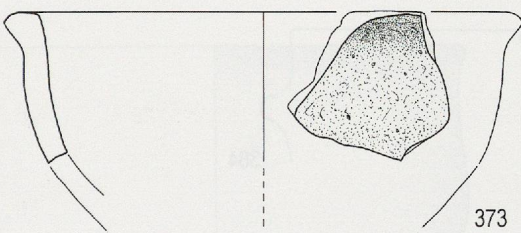
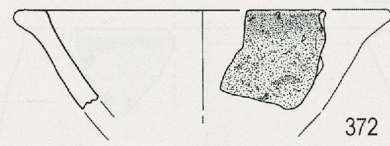
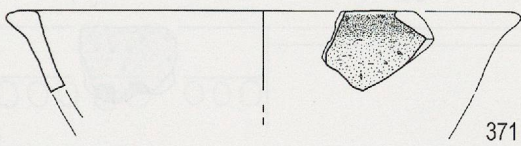
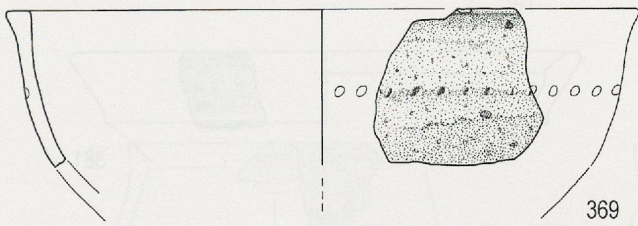
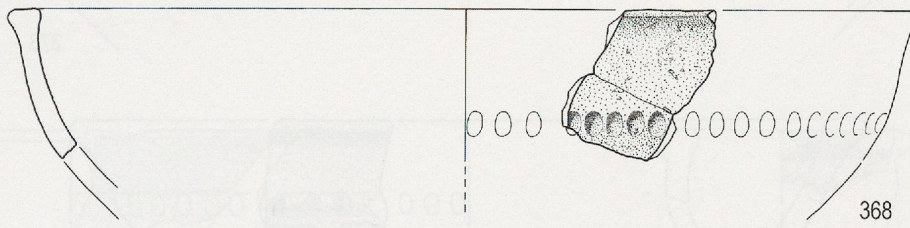
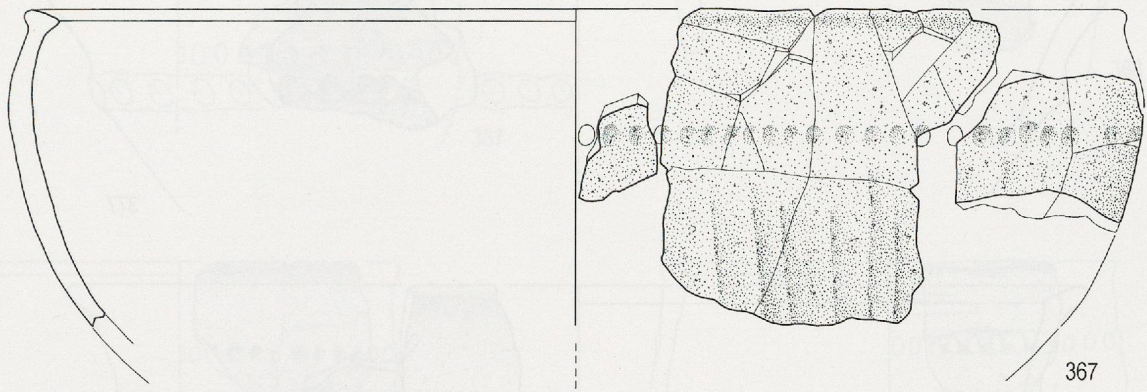

Pl. 27. Montricher VD Châtel d'Arruffens. Bronze moyen/récent. Ecuellen en céramique grossière (éch. 1:3).

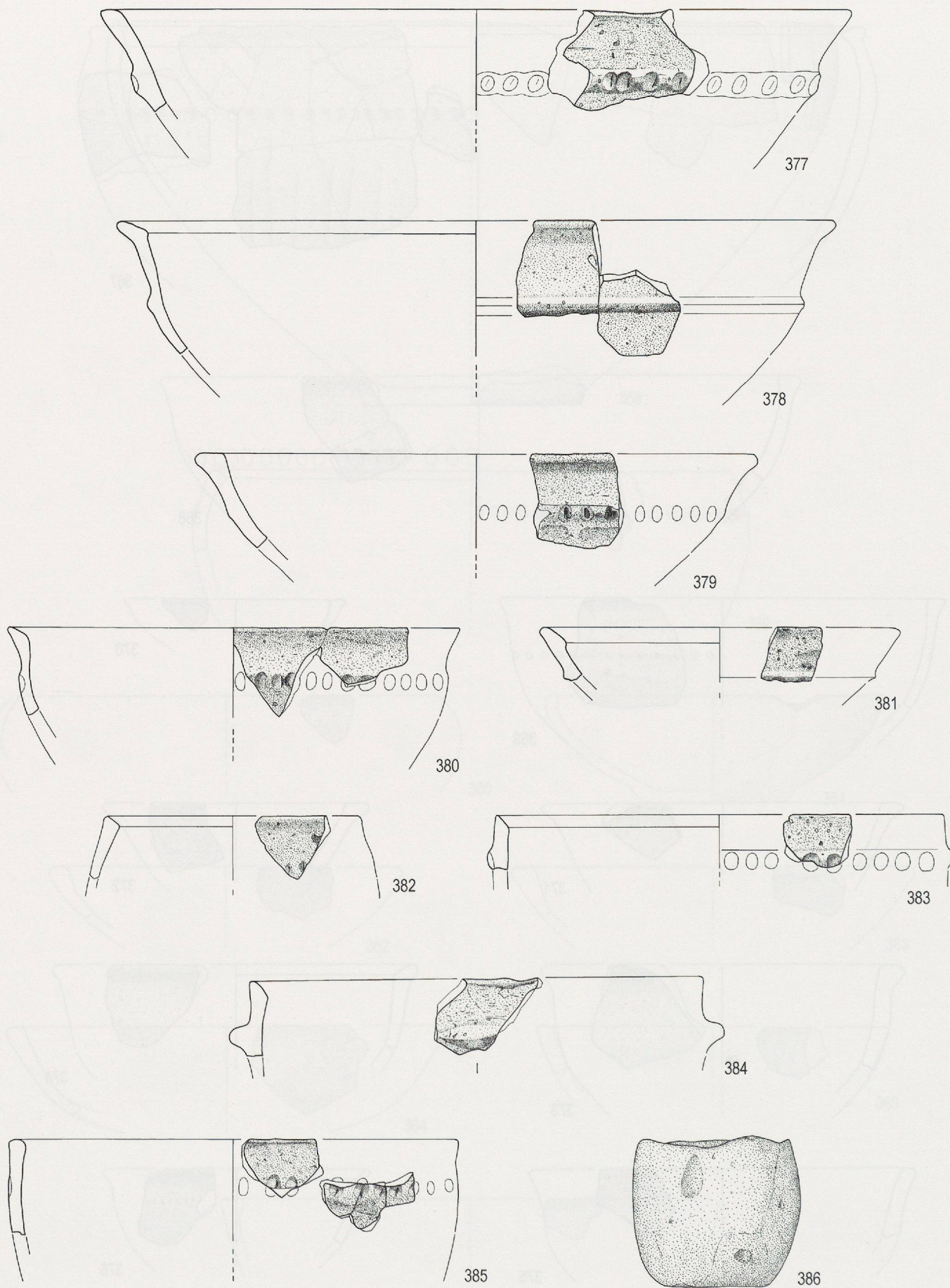

Pl. 28. Montricher VD Châtel d'Arruffens. Bronze moyen/récent. Ecuellen (377-381) et bols ou tasses (382-386) en céramique grossière (éch. 1:3).

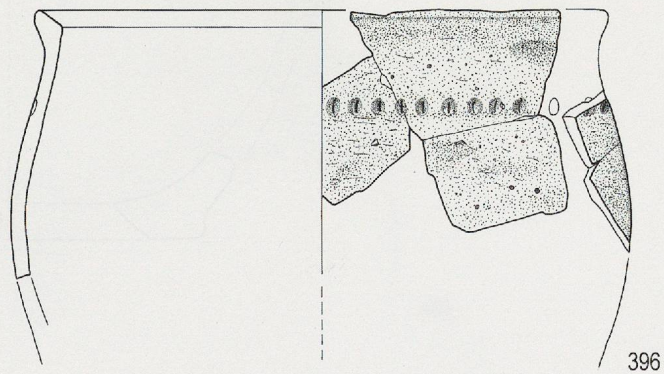
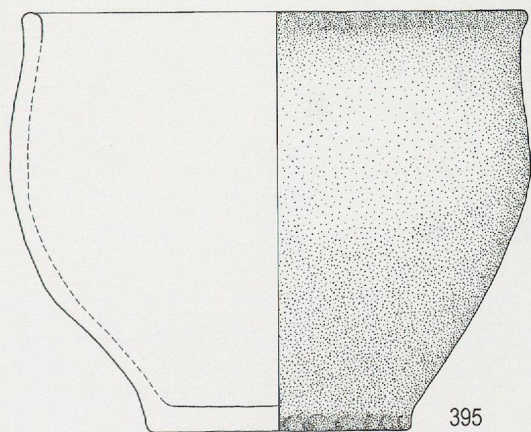
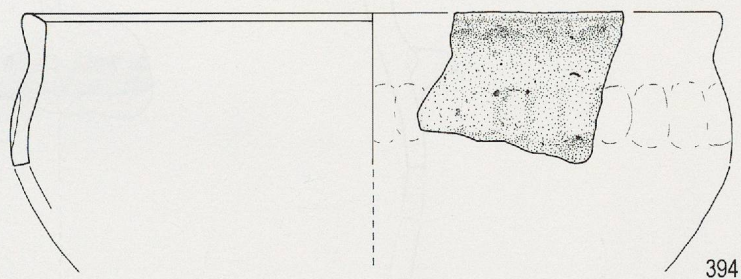
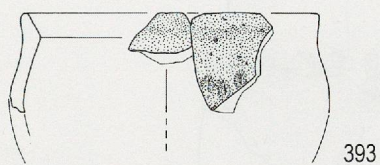
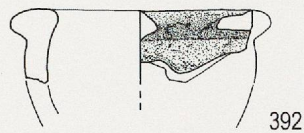
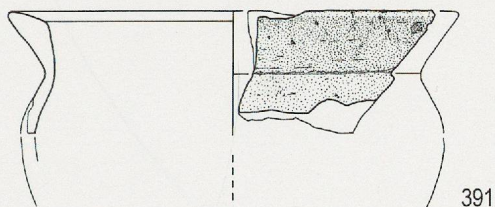
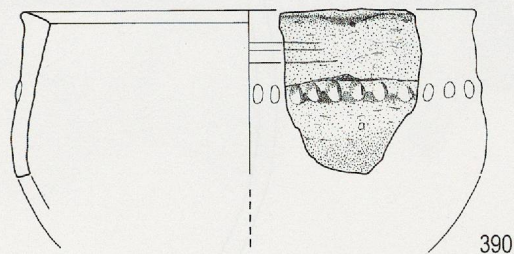
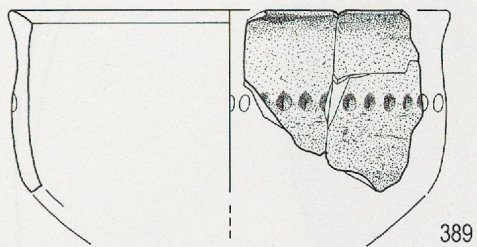
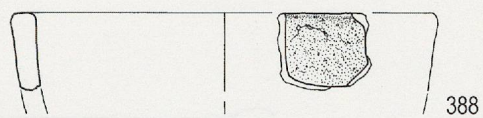
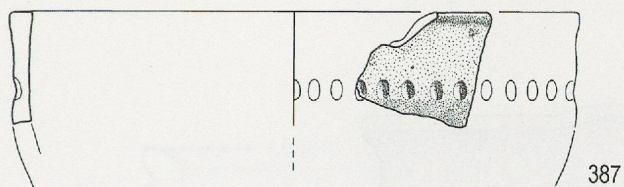

Pl. 29. Montricher VD Châtel d'Arruffens. Bronze moyen/récent. Euelles (377-381) et bols ou tasses (382-386) en céramique grossière (éch. 1:3).

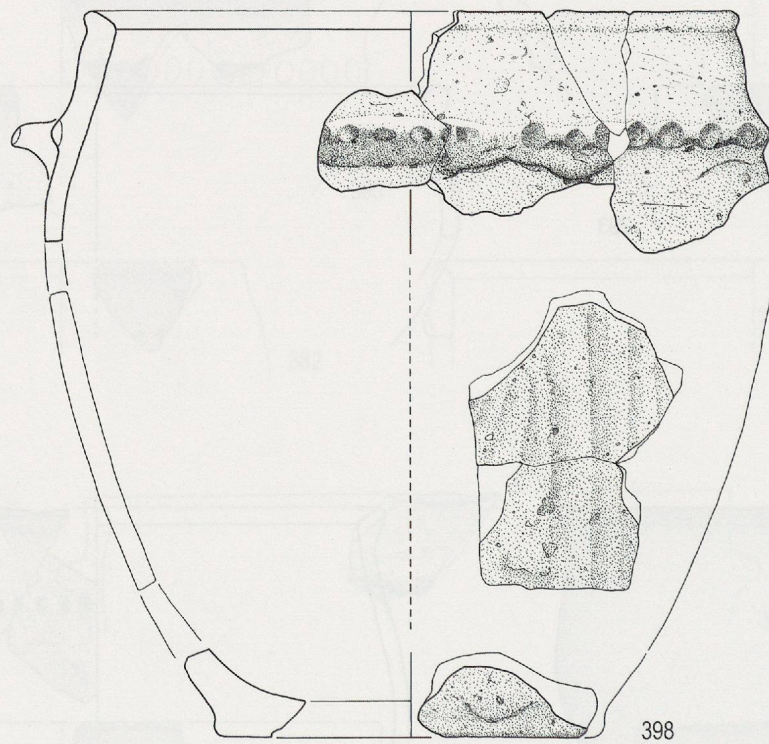
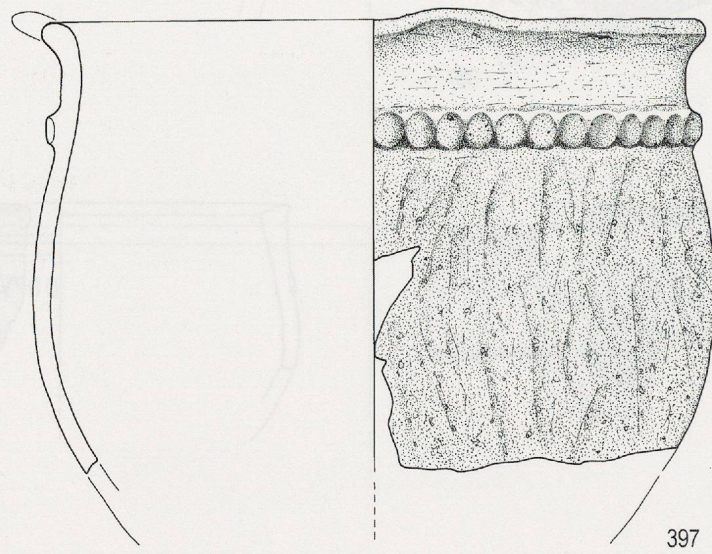

Pl. 30. Montricher VD Châtel d'Arruffens. Bronze moyen/récent. Grands plats creux en céramique grossière (éch. 1:3).

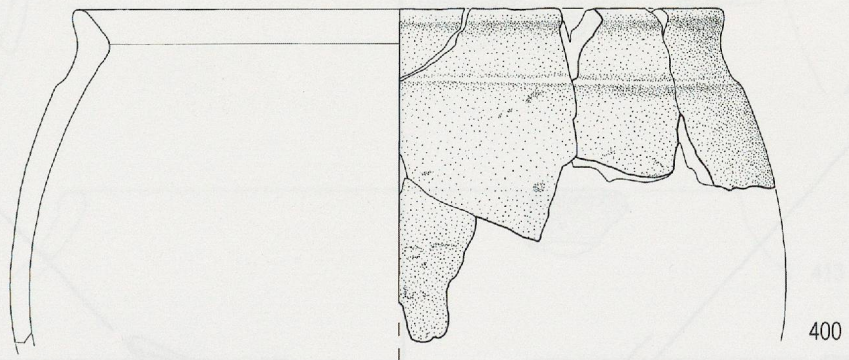

Pl. 31. Montricher VD Châtel d'Arruffens. Bronze moyen/récent. Grands plats creux en céramique grossière (éch. 1:3).



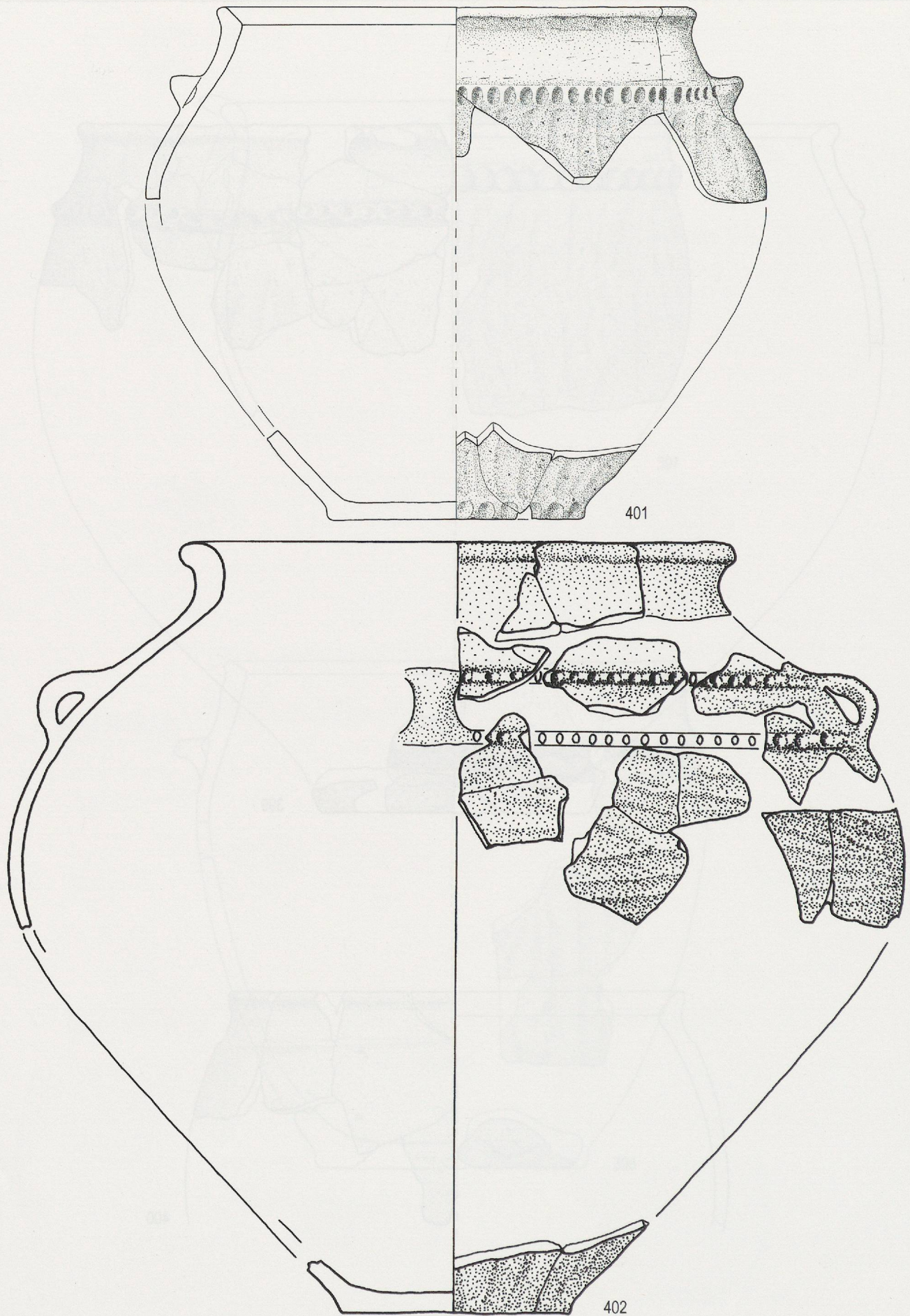

Pl. 32. Montricher VD Châtel d'Arruffens. Bronze moyen/récent. Pots biconiques en céramique grossière (401, éch. 1:3; 402, éch. 1:4).

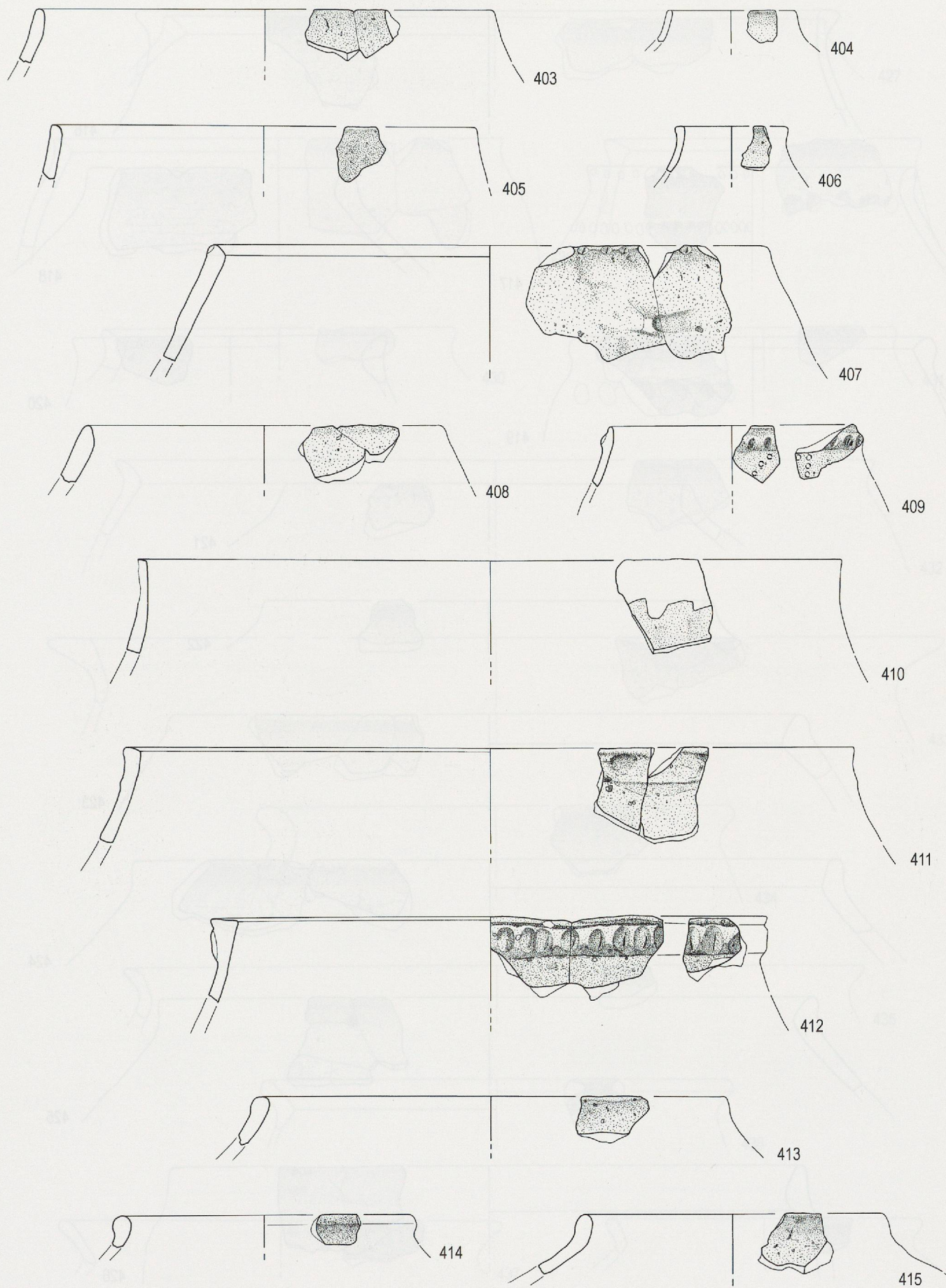

Pl. 33. Montricher VD Châtel d'Arruffens. Bronze moyen/récent. Corps à épaule rentrante sans encolure (403-414) et rebord cylindrique (415) en céramique grossière (éch. 1:3).

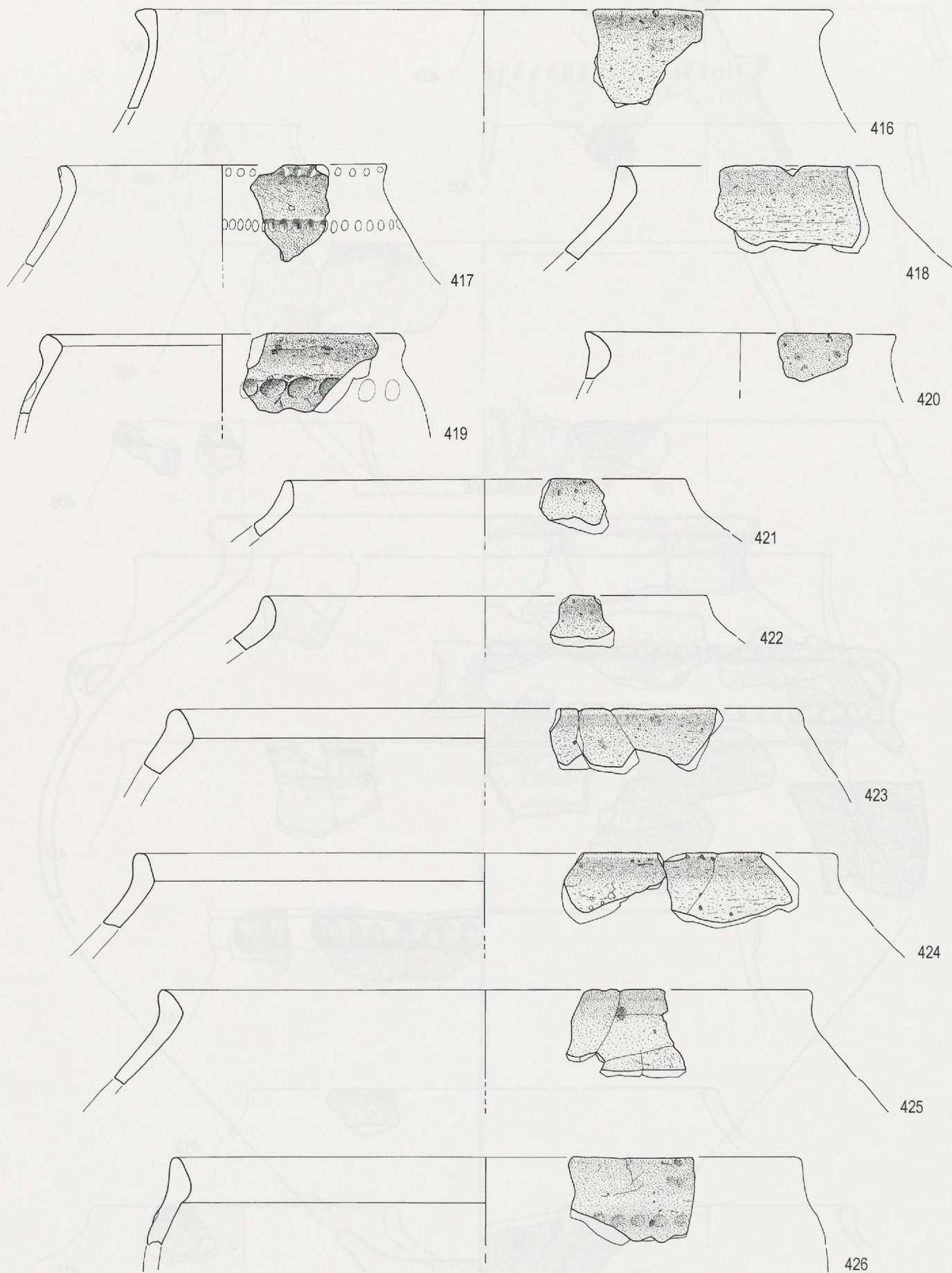

Pl. 34. Montrichier VD Châtel d'Arruffens. Bronze moyen/récent. Rebords cylindriques en céramique grossière (éch. 1:3).

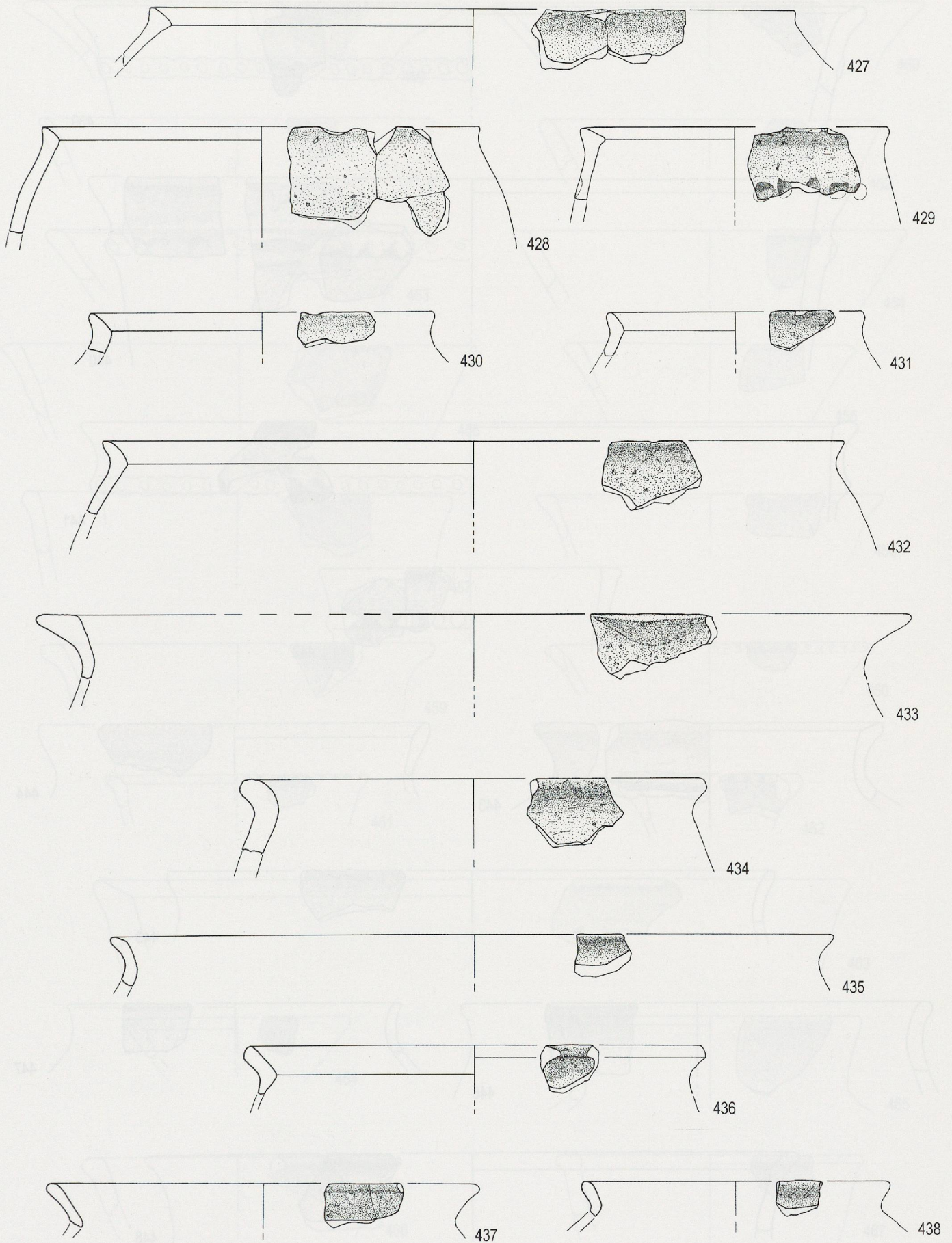

Pl. 35. Montricher VD Châtel d'Arruffens. Bronze moyen/récent. Rebords cylindrique (427) et évasés (428-438) en céramique grossière (éch. 1:3).

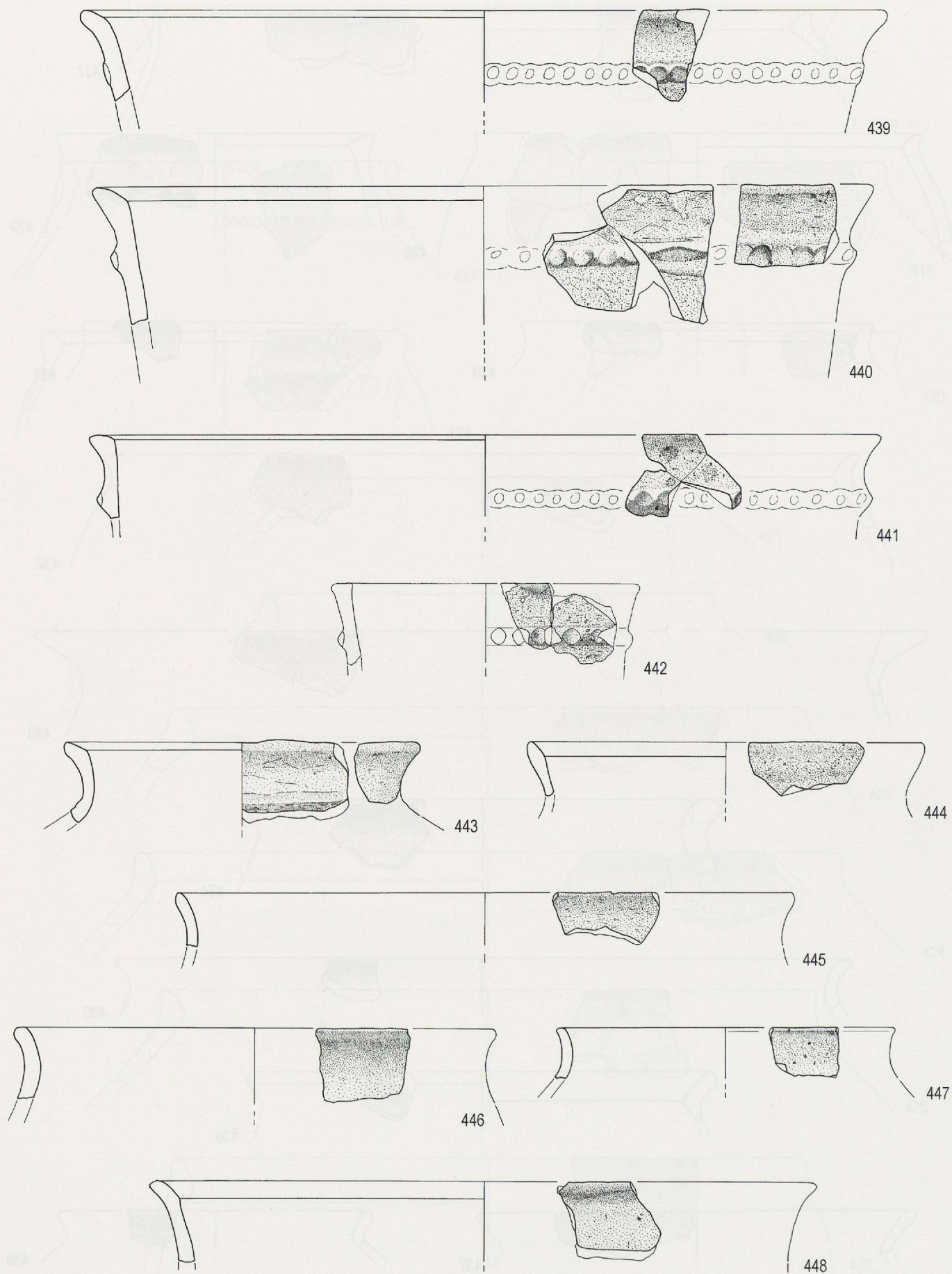

Pl. 36. Montricher VD Châtel d'Arruffens. Bronze moyen/récent. Récipients à corps et col évasés (439-442) et cols incurvés évasés (443-448) en céramique grossière (éch. 1:3).

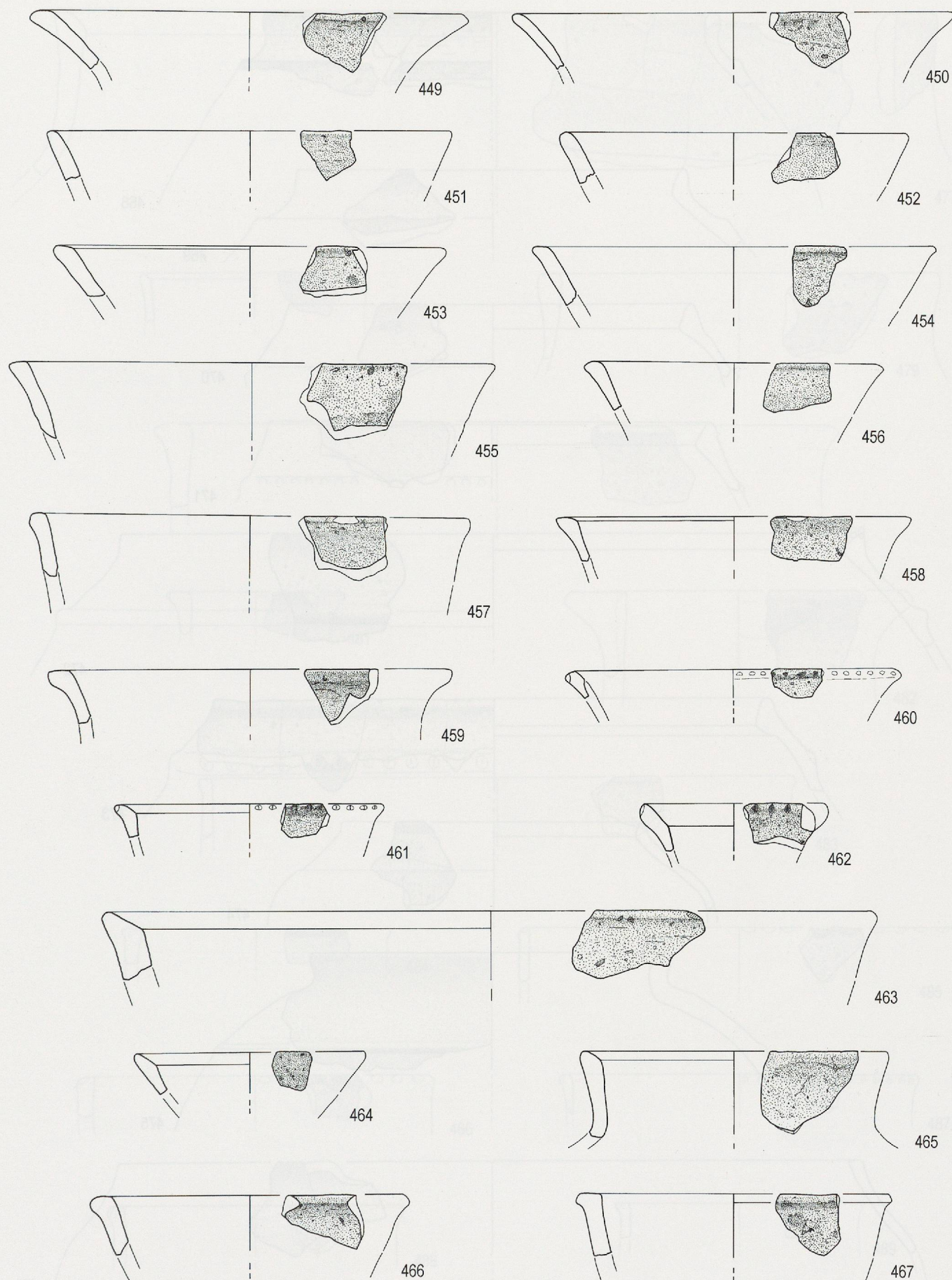

Pl. 37. Montricher VD Châtel d'Arruffens. Bronze moyen/récent. Cols évasés en céramique grossière (éch. 1:3).

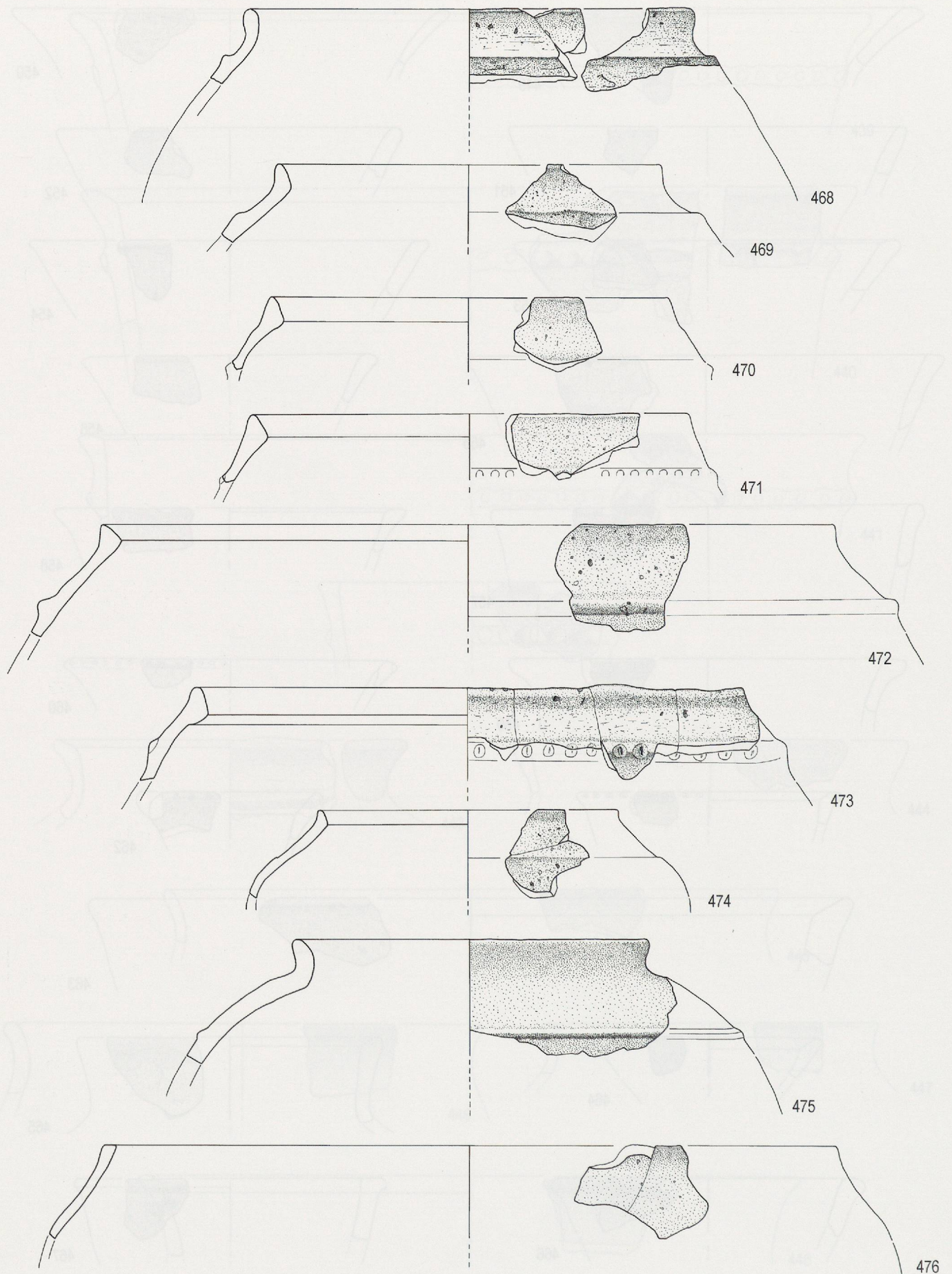

Pl. 38. Montricher VD Châtel d'Arruffens. Bronze moyen/récant. Cols rentrants individualisés en céramique grossière (éch. 1:3).

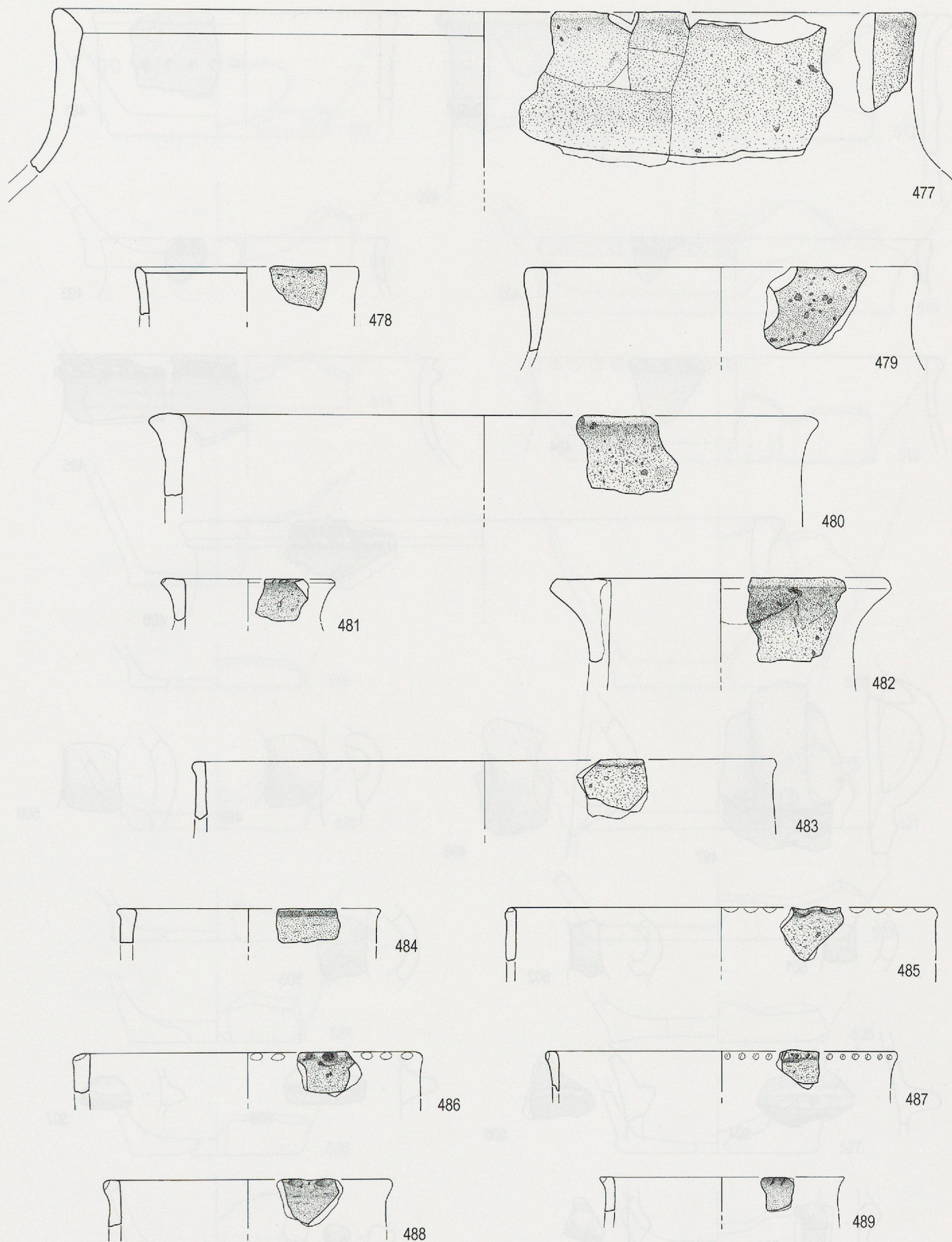

Pl. 39. Montricher VD Châtel d'Arruffens. Bronze moyen/récent. Cols cylindriques en céramique grossière (éch. 1:3).



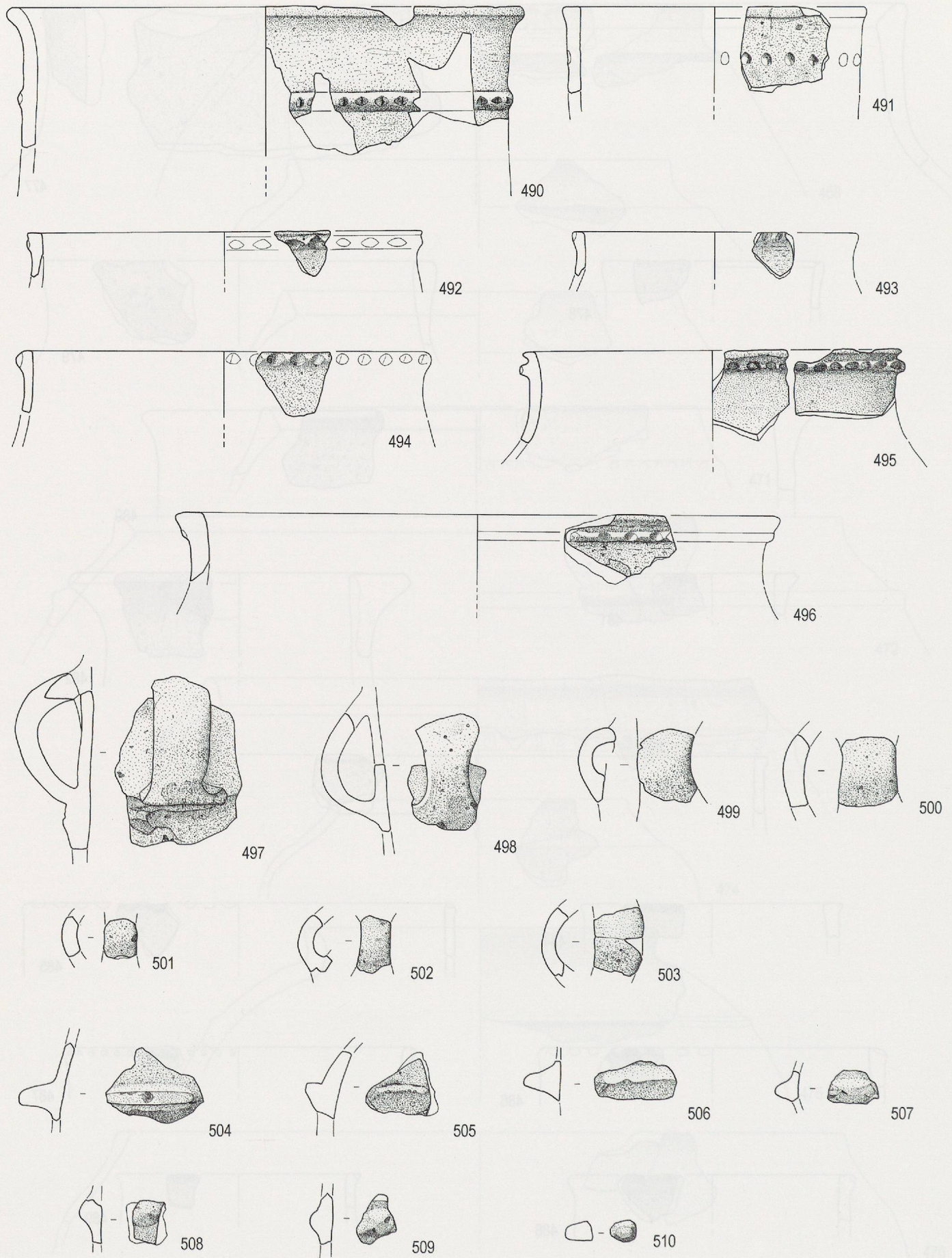

Pl. 40. Montricher VD Châtel d'Arruffens. Bronze moyen/récent. Cols cylindriques (490-496), anses (497-503), languettes (504-507) et mamelons (508-510) en céramique grossière (éch. 1:3).

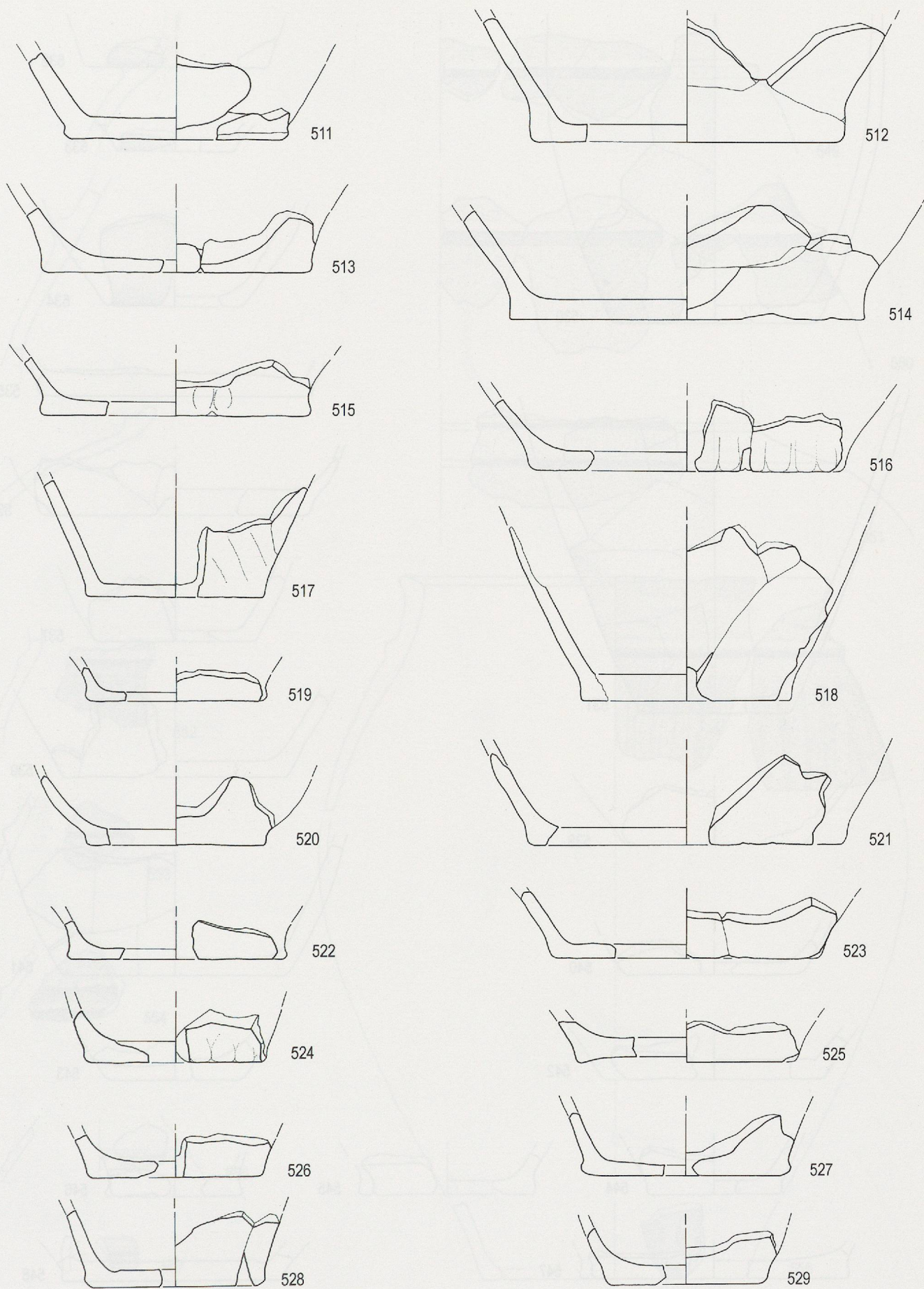

Pl. 41. Montricher VD Châtel d'Arruffens. Bronze moyen/récent. Bases plates à amorce de pied en céramique grossière (éch. 1:3).

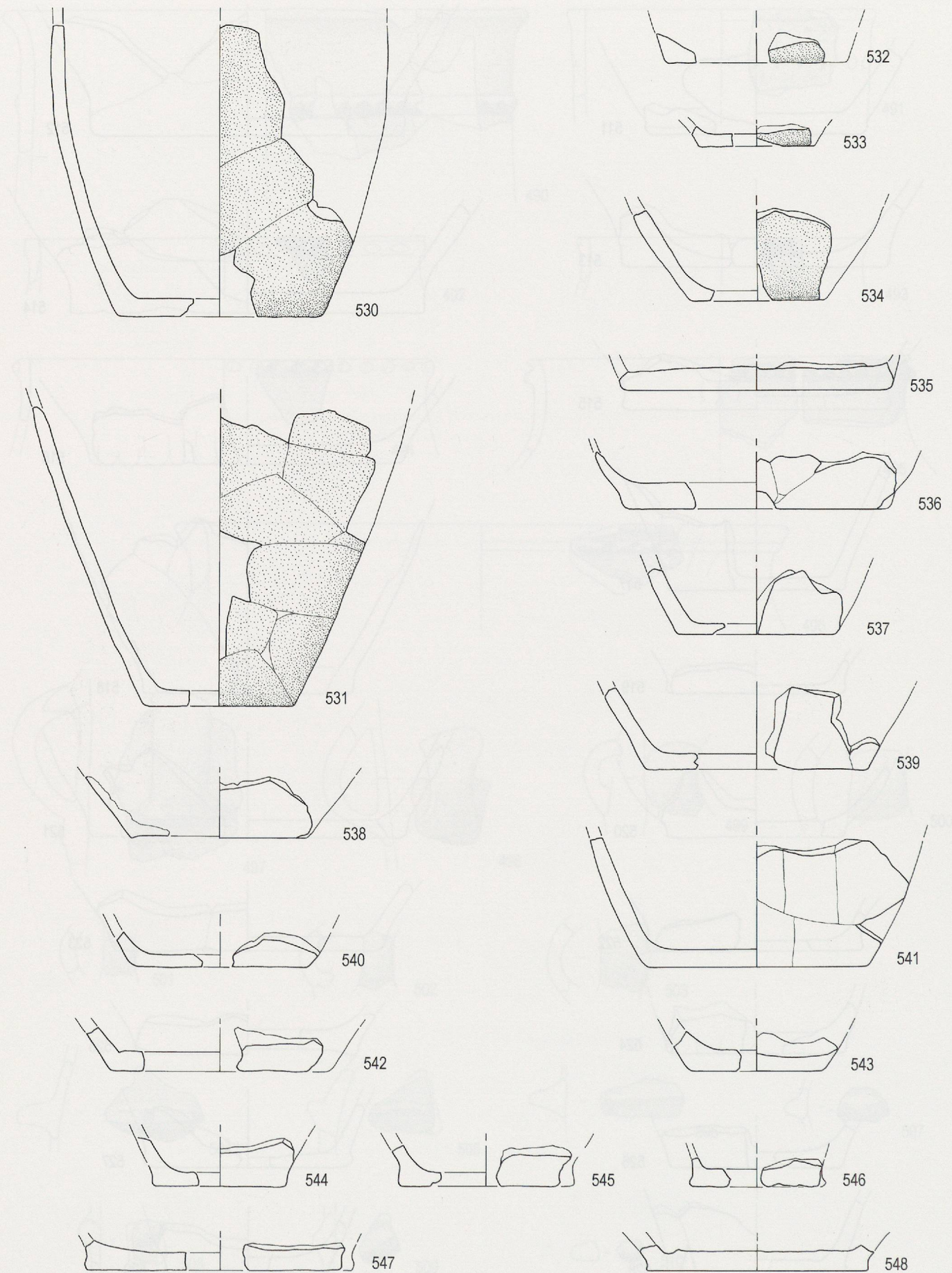

Pl. 42. Montricher VD Châtel d'Arruffens. Bronze moyen/récent. Bases plates (530-543) et plates à amorce de pied (544-548) en céramique grossière (éch. 1:3).

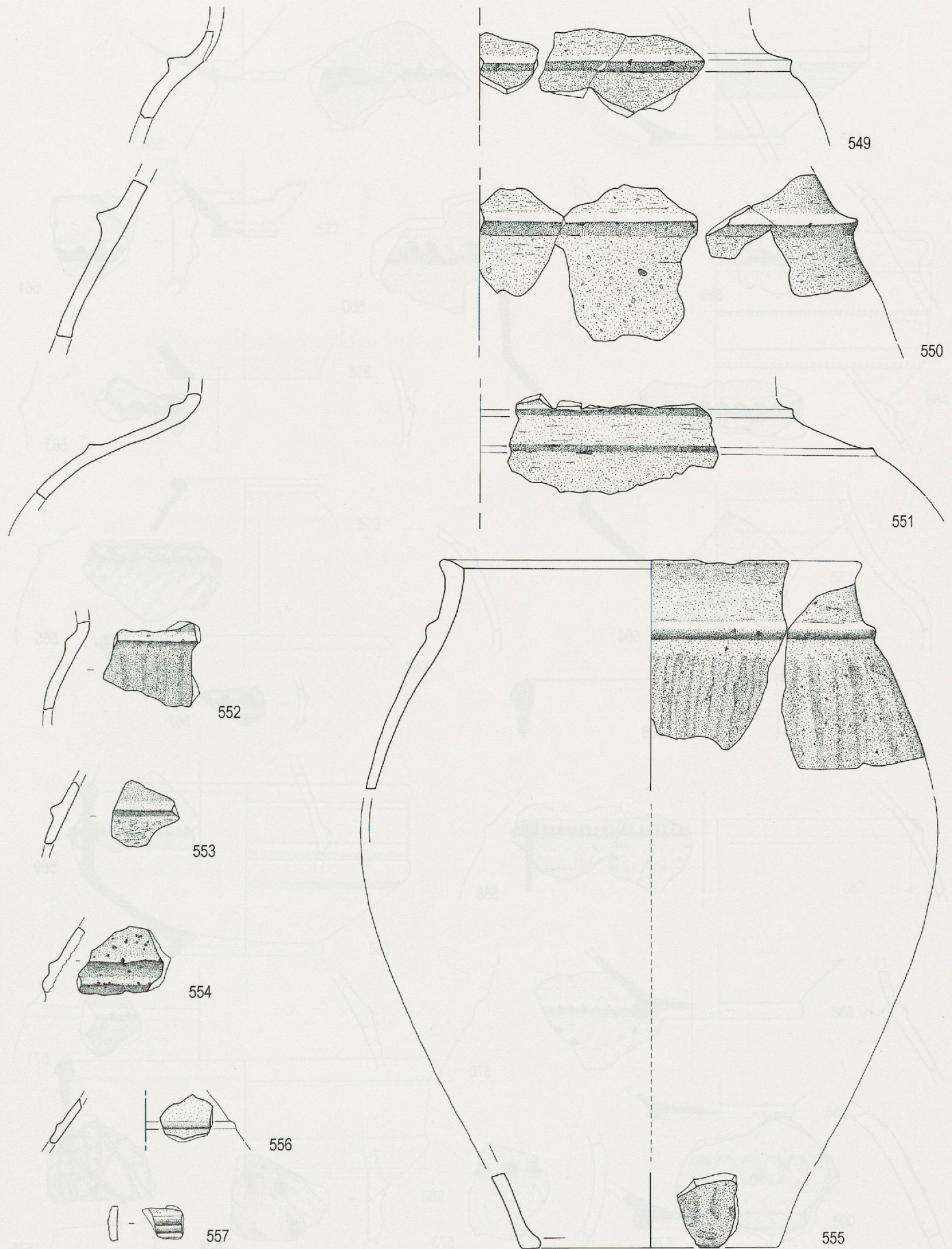

Pl. 43. Montricher VD Châtel d'Arruffens. Bronze moyen/récent. Cordons lisses horizontaux en céramique grossière (549-554) et fine (556-557), jarre en tonnelet (555) en céramique grossière (éch. 1:3).

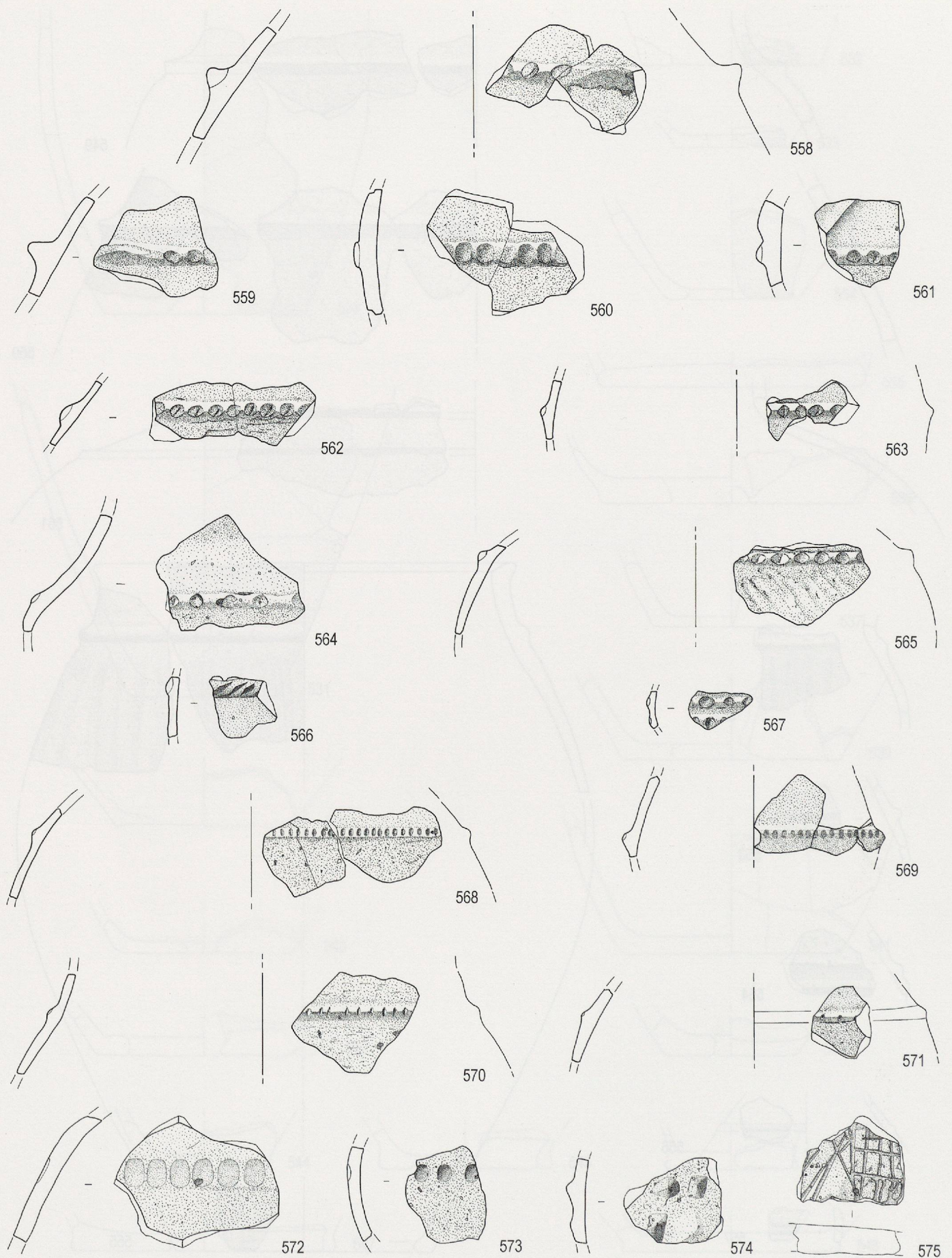

Pl. 44. Montricher VD Châtel d'Arruffens. Bronze moyen/récent. Cordons impressionnés (558-571), lignes d'impressions digitales (572-573), mamelons couvrants (574) et réseau d'incisions (575) en céramique grossière (éch. 1:3).

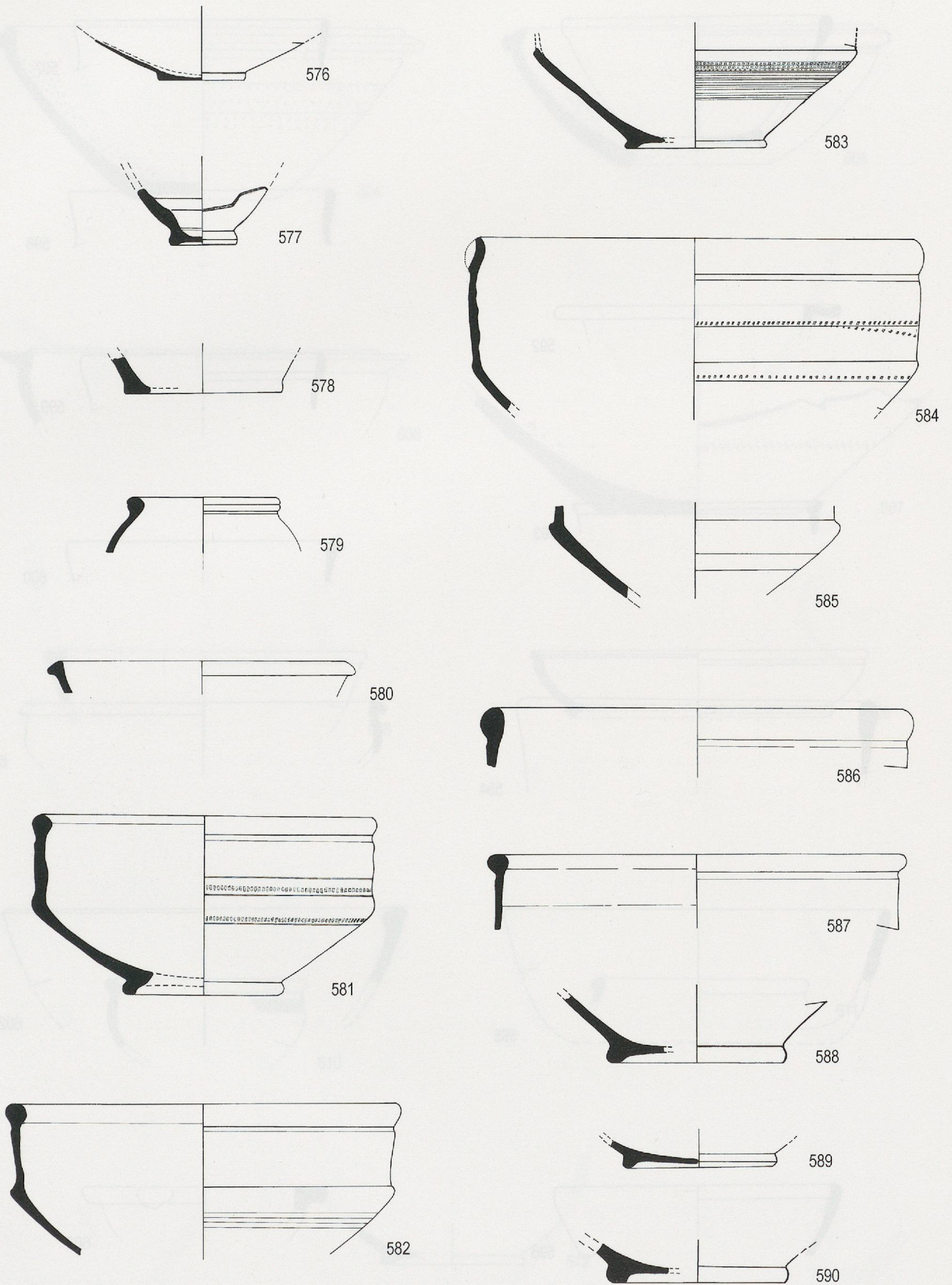

Pl. 45. Montricher VD Châtel d'Arruffens. Bas-Empire. Céramique à revêtement argileux (576-590) (éch. 1:3).

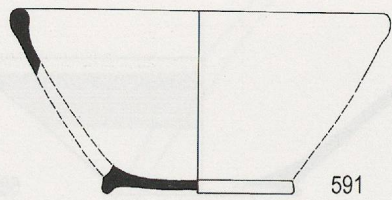

591

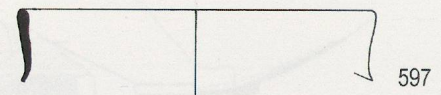

597

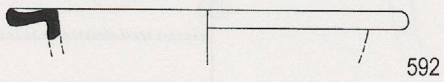

592

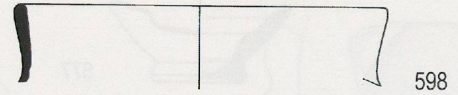

598

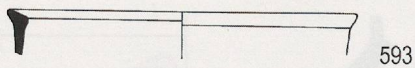

593

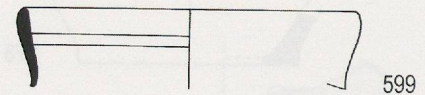

599

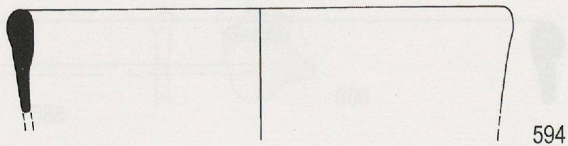

594

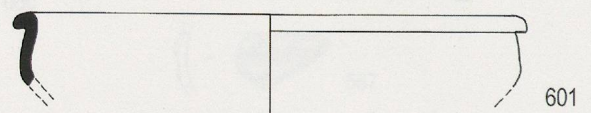

601

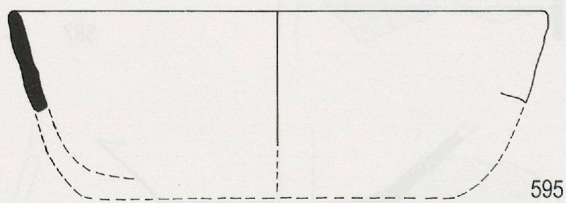

595

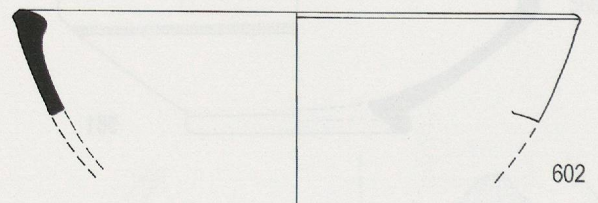

602

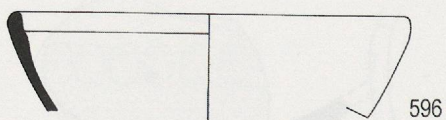

596

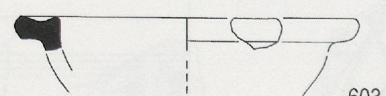

603

Pl. 46. Montricher VD Châtel d'Arruffens. Bas-Empire. Céramique à revêtement argileux (591-600) ; céramique sans revêtement apparent (601-603) (éch. 1:3).

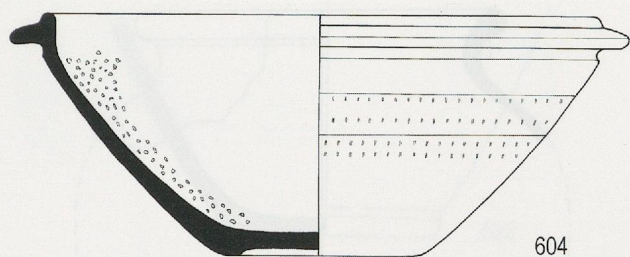

604

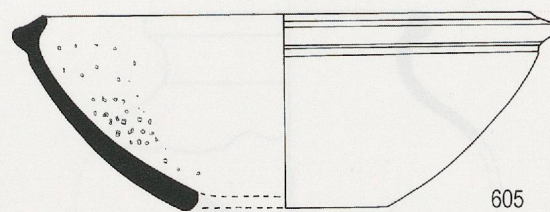

605

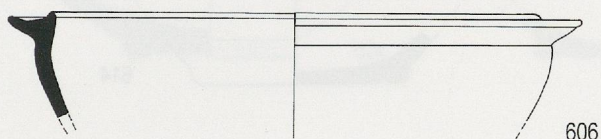

606

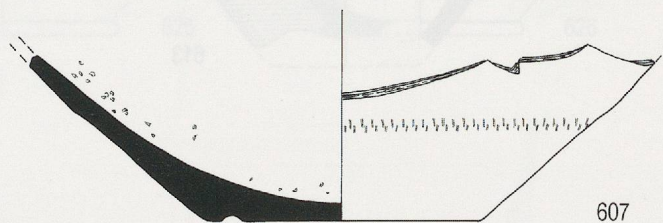

607

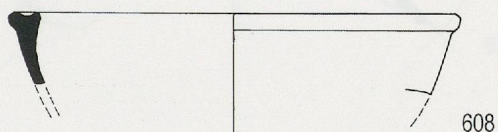

608

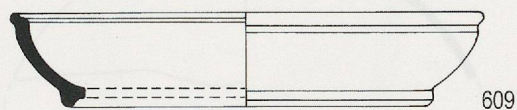

609

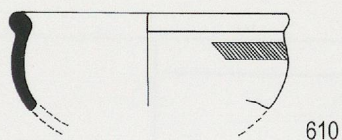

610

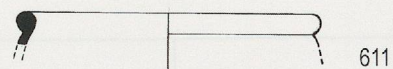

611

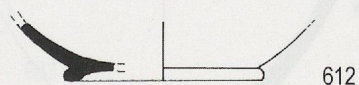

612

Pl. 47. Montricher VD Châtel d'Arruffens. Bas-Empire. Céramique à revêtement argileux (604-608); céramique dérivée de sigillées paléochrétiennes (609-612) (éch. 1:3).



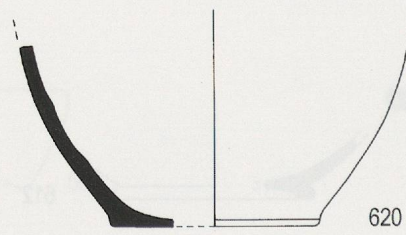
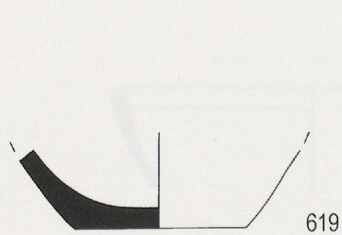
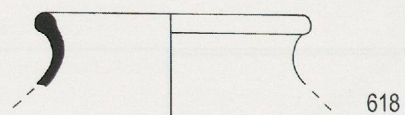
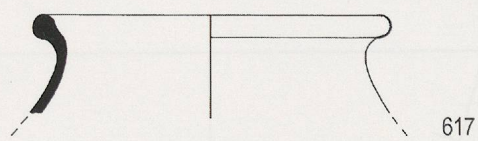
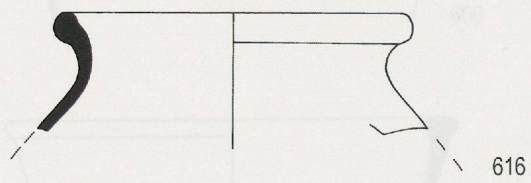
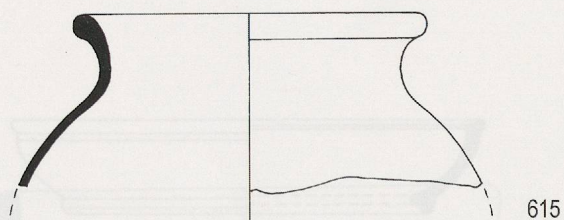
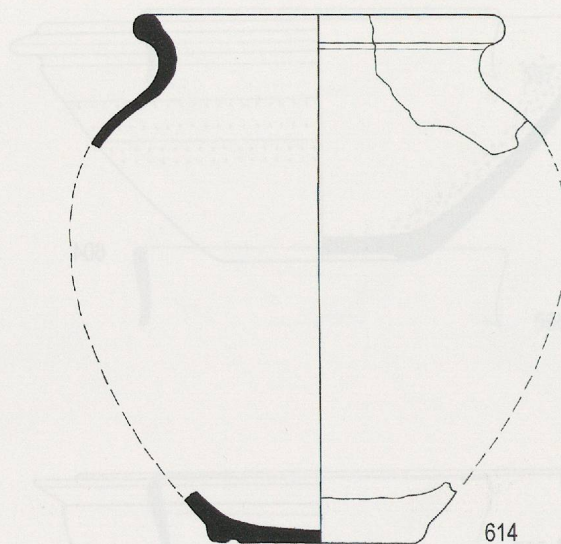
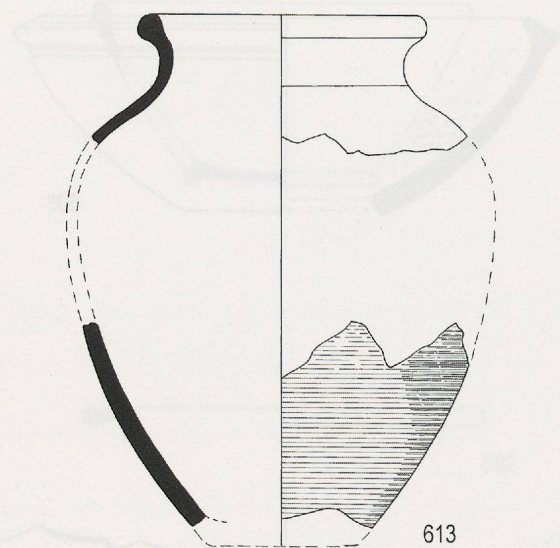

Pl. 48. Montricher VD Châtel d'Arruffens. Bas-Empire. Céramique grossière à pâte sombre (613-621) (éch. 1:3).

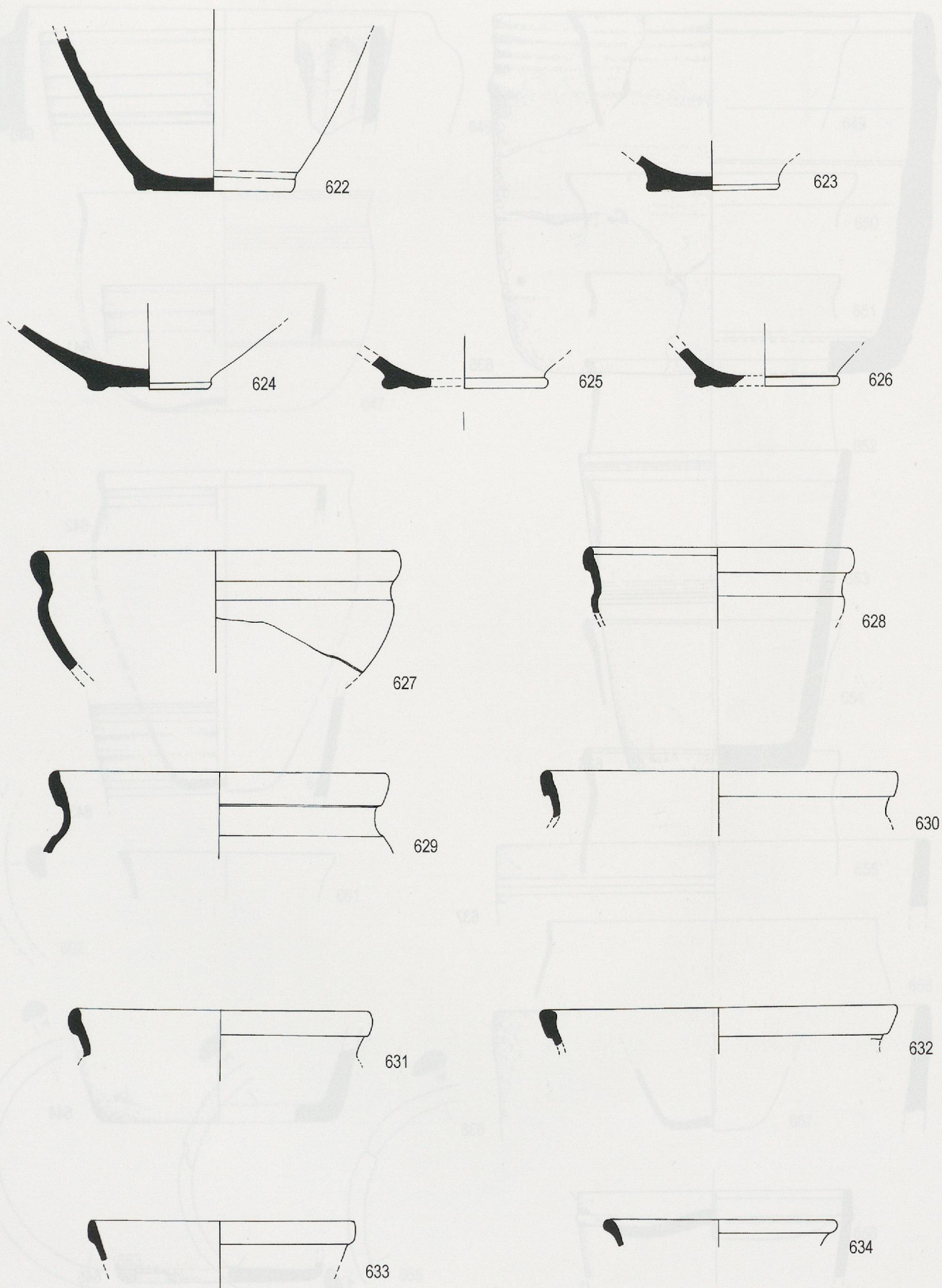

Pl. 49. Montricher VD Châtel d'Arruffens. Bas-Empire. Céramique grossière à pâte sombre (622-634) (éch. 1:3).

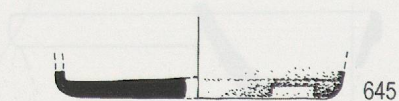
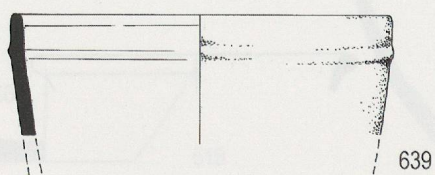
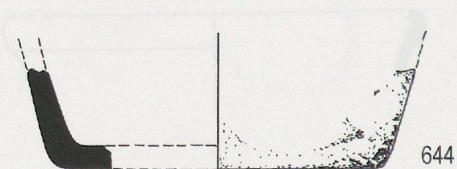
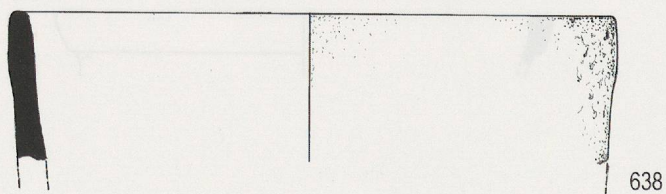
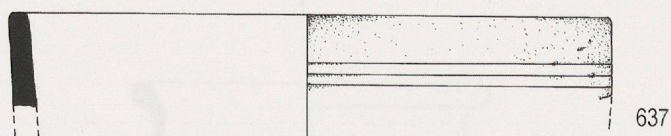
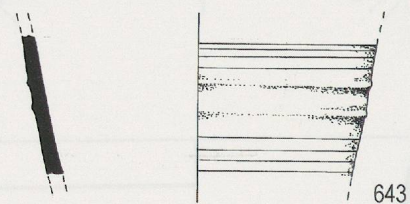
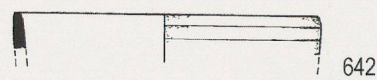
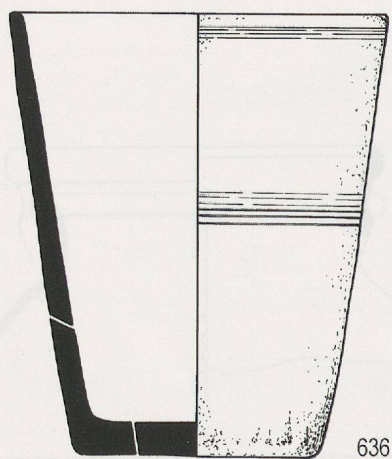
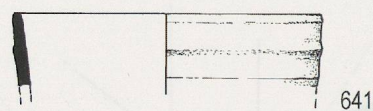
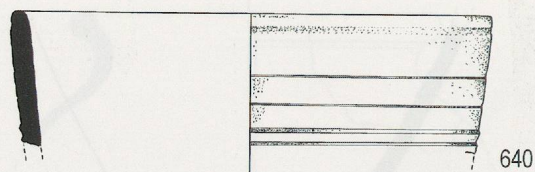
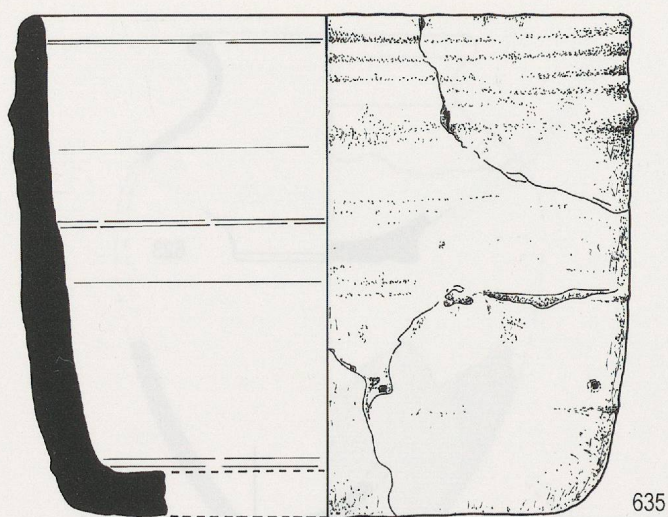

Pl. 50. Montricher VD Châtel d'Arruffens. Bas-Empire. Pierre ollaire (635-645) (éch. 1:3).

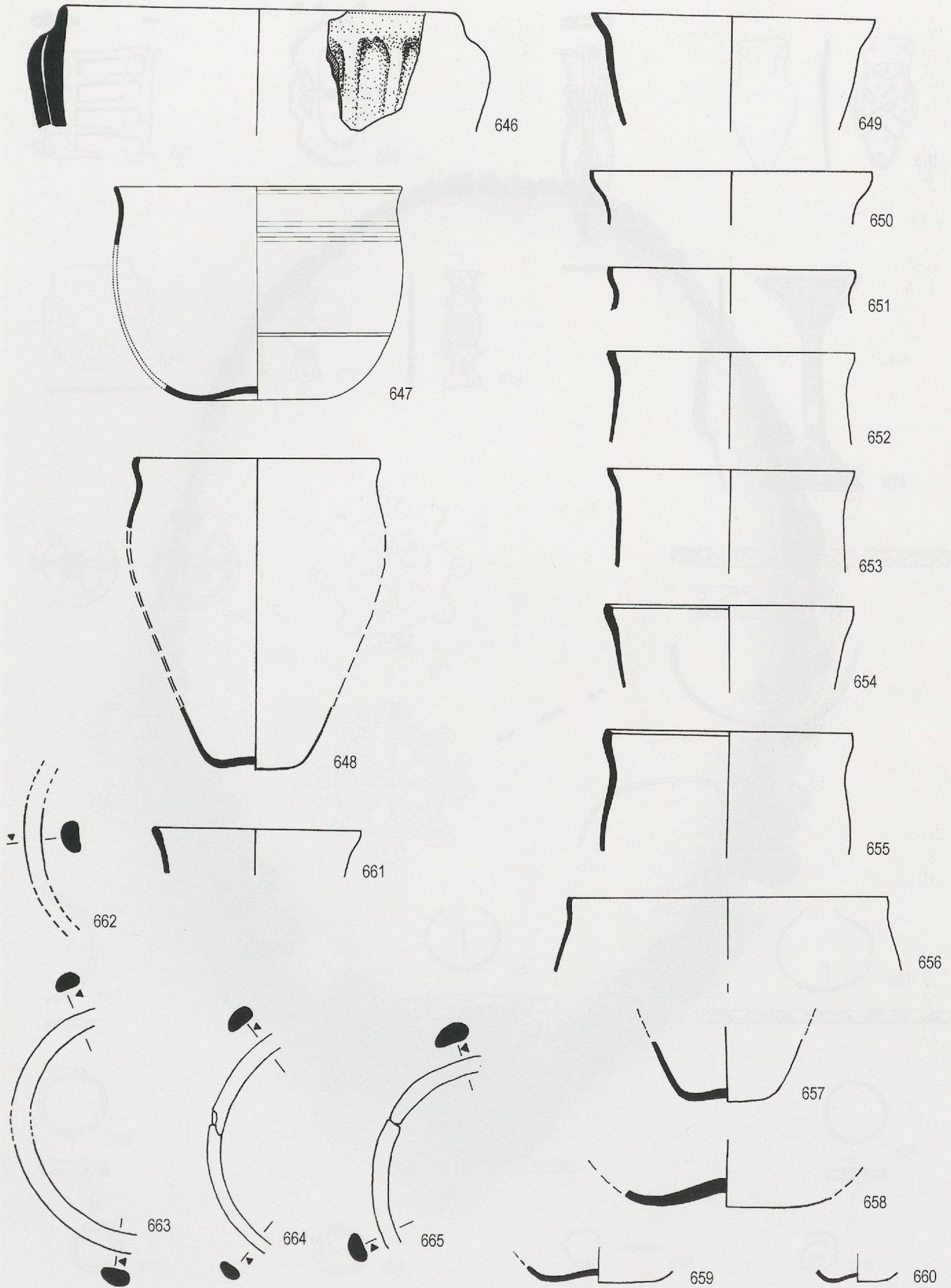

Pl. 51. Montricher VD Châtel d'Arruffens. Bas-Empire. Verre. Bols et gobelets (646-661); bracelets (662-665) (éch. 2/3).



Pl. 52. Montricher VD Châtel d'Arruffens. Bas-Empire. Perles en verre. Diam. de la grande perle: 33 mm (Musée cantonal d'archéologie et d'histoire de Lausanne, photo Fibbi-Aeppli, Grandson).

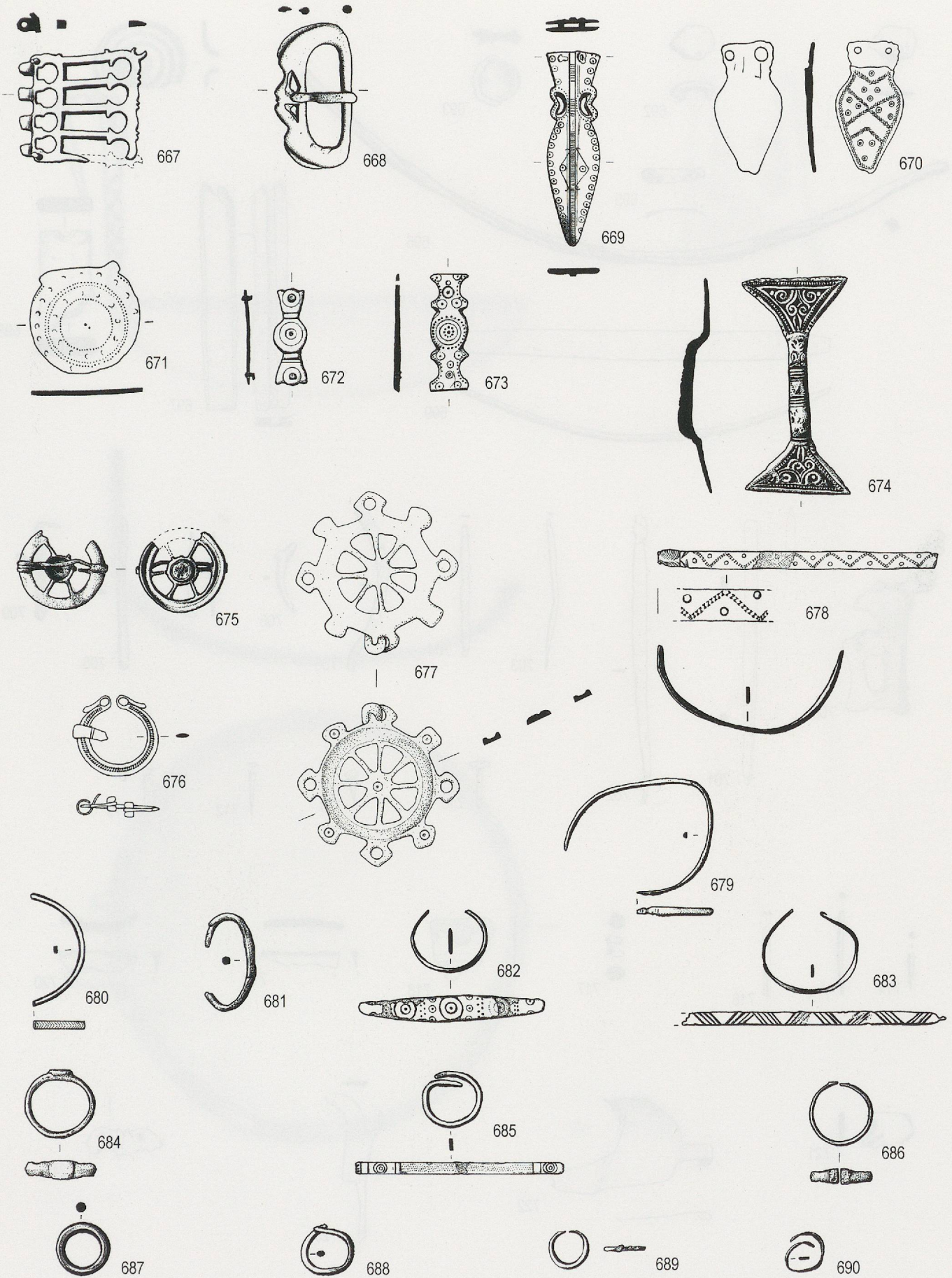

Pl. 53. Montricher VD Châtel d'Arruffens. Bas-Empire. Bronze. Éléments de ceinturons (667-674); fibules et rouelle (675-677); bracelets, bagues et anneaux (678-690) (éch. 1:2).

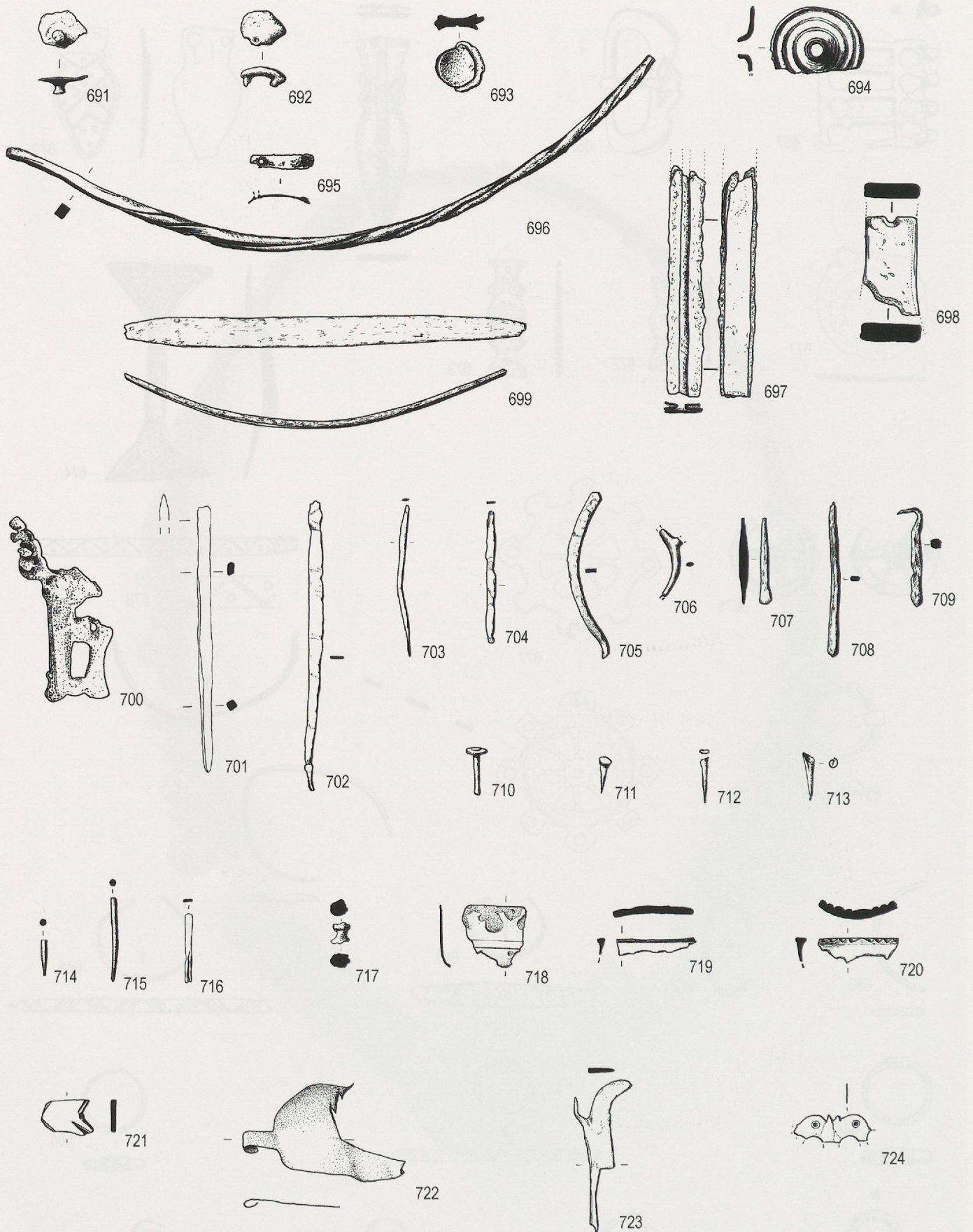

Pl. 54. Montricher VD Châtel d'Arruffens. Bas-Empire. Bronze. Objets divers (691-724) (éch. 1:2).

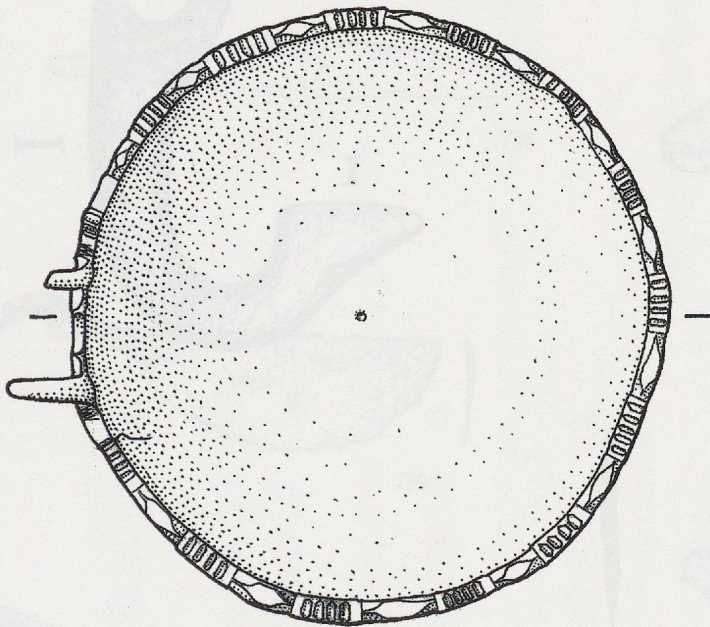
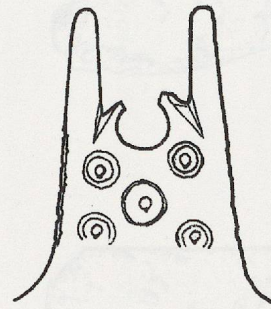
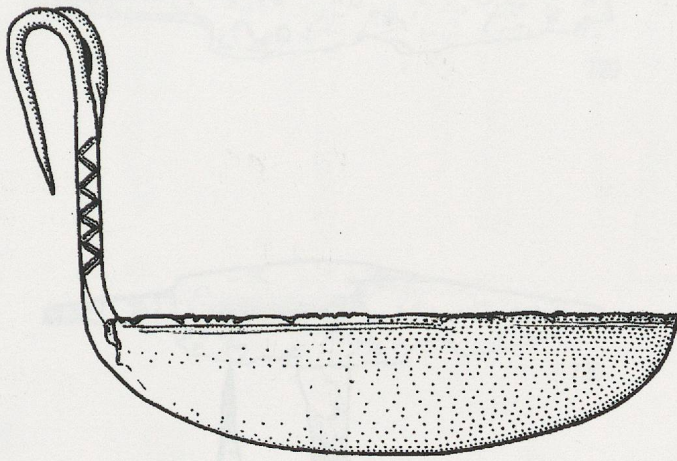

725

Pl. 55. Montricher VD Châtel d'Arruffens. Bas-Empire. Lampe en bronze (éch. 1:1).



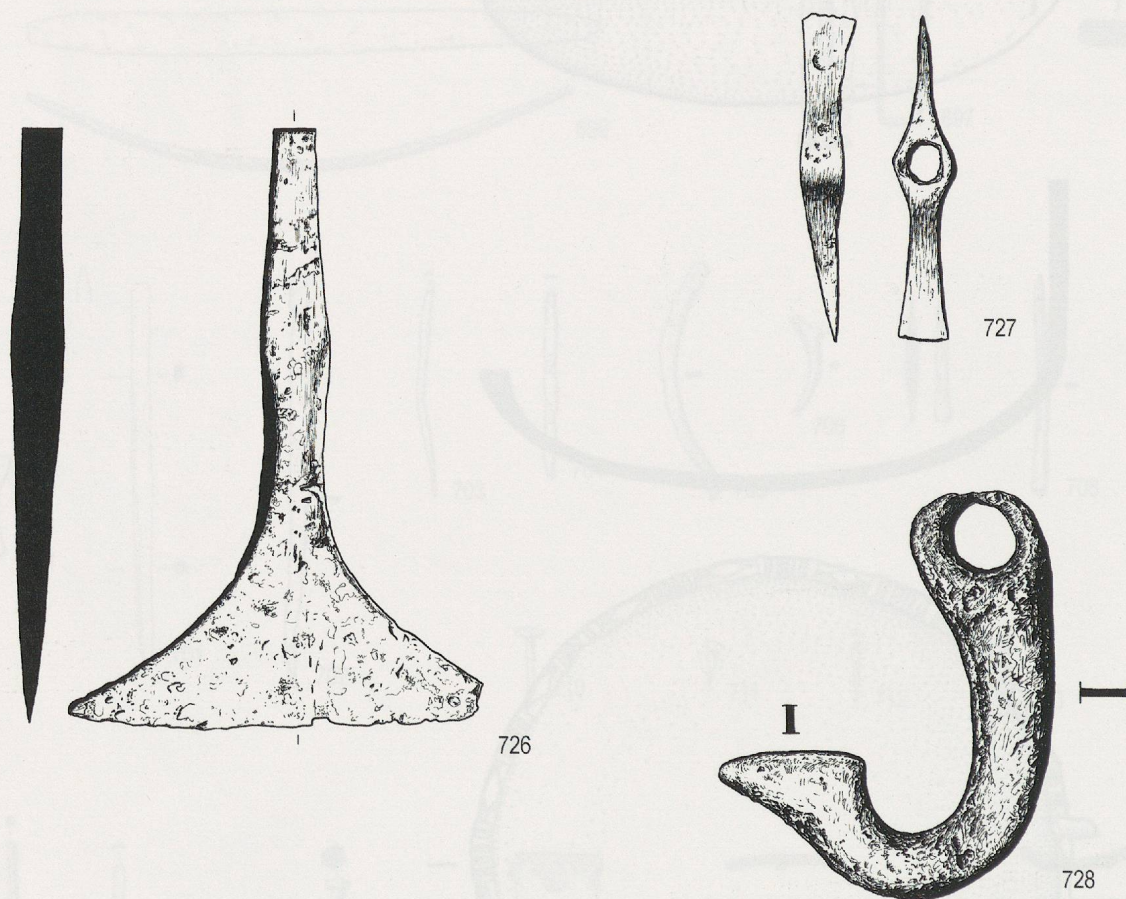

Pl. 56. Montricher VD Châtel d'Arruffens. Bas-Empire. Fer. Tranchet et martelet (726-727); crochet de construction (728) (éch. 1:2).

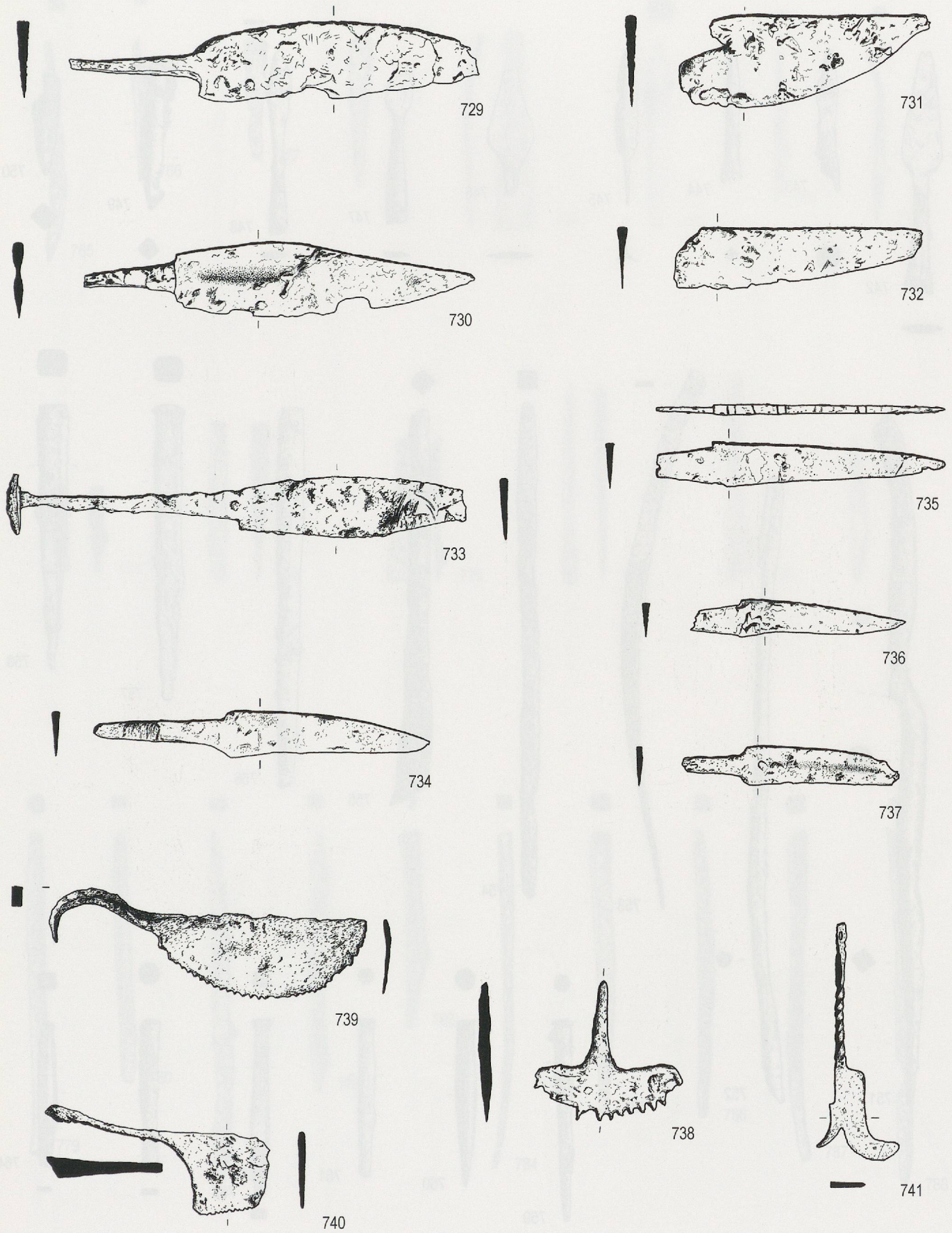

Pl. 57. Montricher VD Châtel d'Arruffens. Bas-Empire. Fer. Couteaux (729-737); outils de sellier (738-740); tranchet (741) (éch. 1:2).

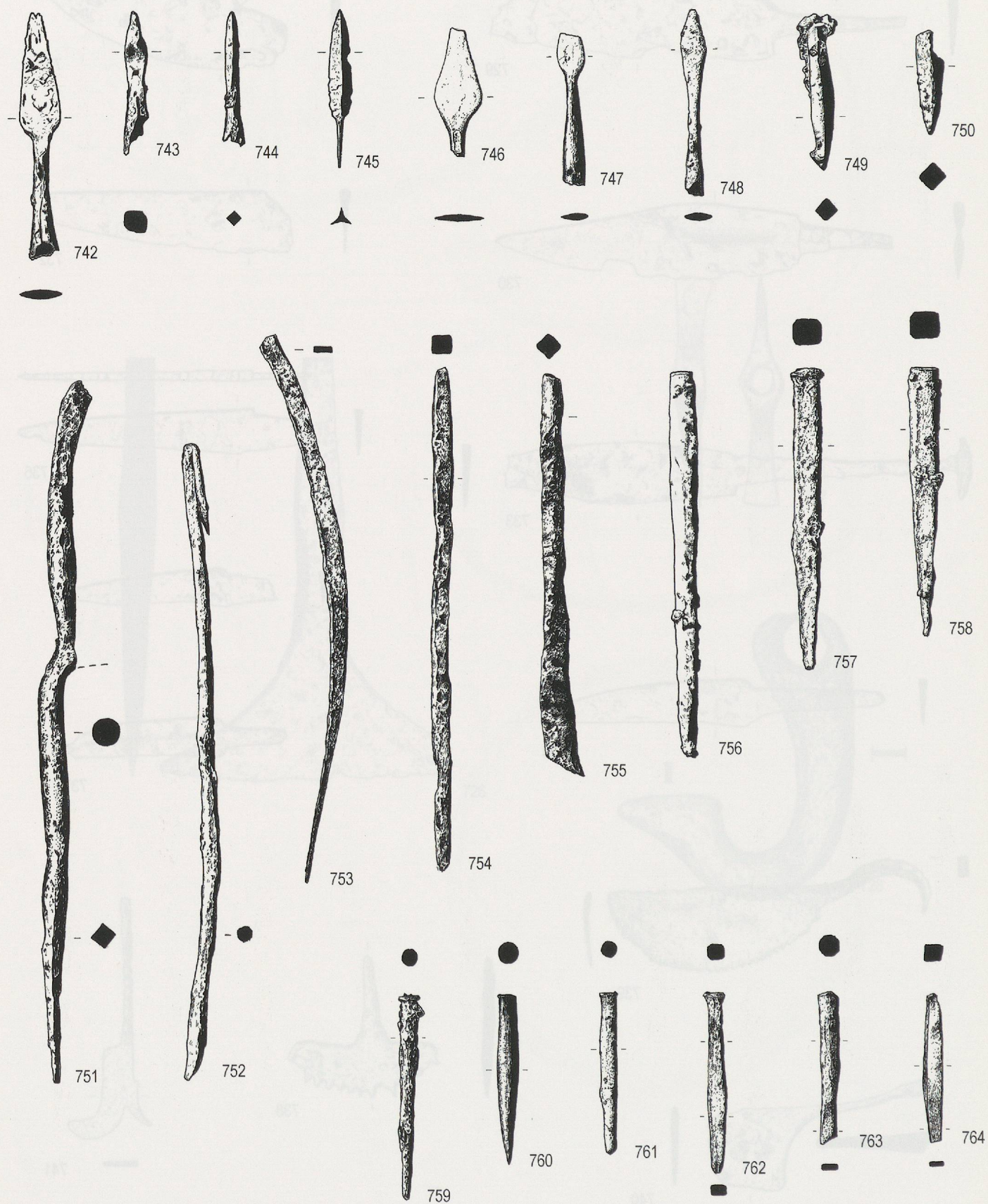

Pl. 58. Montricher VD Châtel d'Arruffens. Bas-Empire. Fer. Pointes de flèches ou de projectiles (742-748; 750). Alènes et burins (749; 751-764) (éch. 1:2).



Pl. 59. Montricher VD Châtel d'Arruffens. Bas-Empire. Fer. Alènes, burins et poinçons (765-775; 778-788); style (776); foret (777) (éch. 1:2).



Pl. 60. Montricher VD Châtel d'Arruffens. Bas-Empire. Fer. Alènes et burins (789-801); objets divers (802-815) (éch. 1:2).



Pl. 61. Montricher VD Châtel d'Arruffens. Bas-Empire. Fer. Alènes ou poinçons (816-818); clous (819-842 et 845); crampons (843-844); agrafe (846); clous ou rivets (847-850) (éch. 1:2).



Pl. 62. Montricher VD Châtel d'Arruffens. Bas-Empire. Fer. Fibule (851); boucle de ceinturon (852); objets divers (853-883) (éch. 1:2).

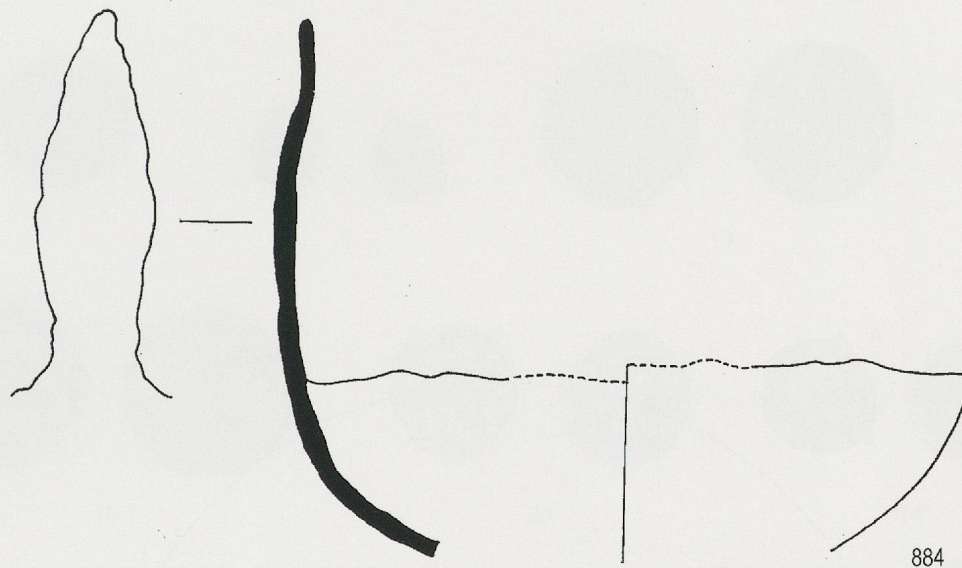

884

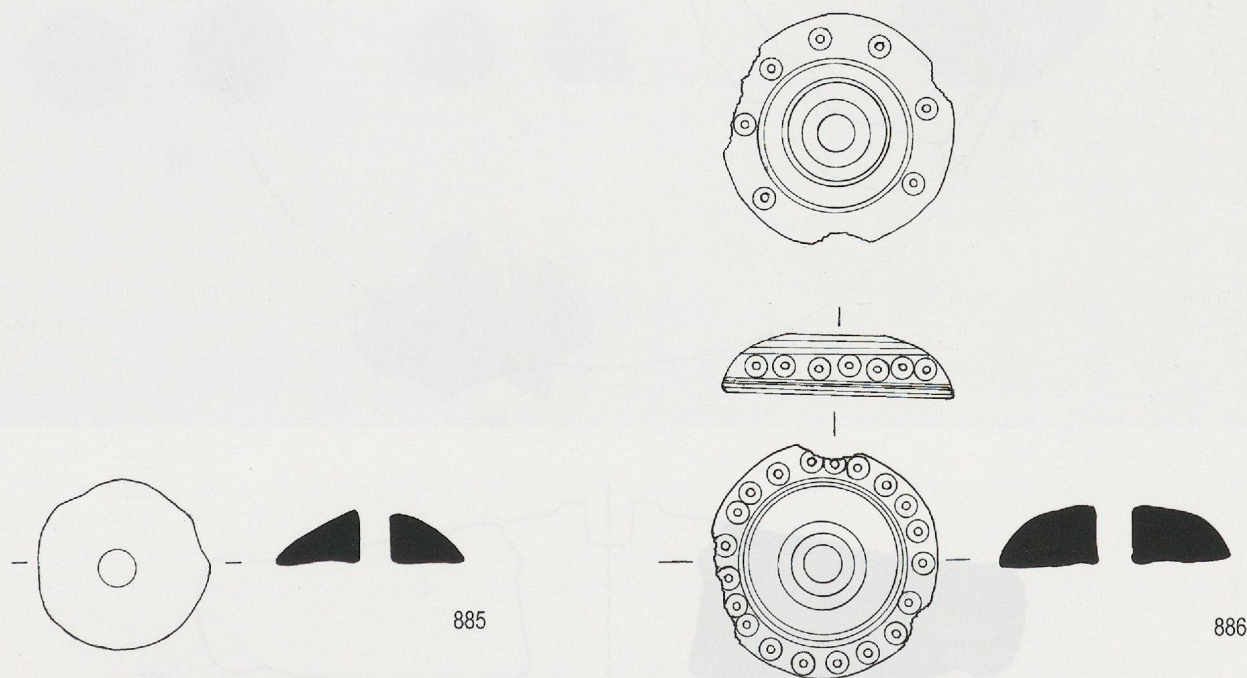

885

886

Pl. 63. Montricher VD Châtel d'Arruffens. Bas-Empire. Lampe en fer (884) (éch. 1:2); fusaiöle en plomb (885) (éch. 1:3), fusaiöle en os (886) (éch. 1:2).



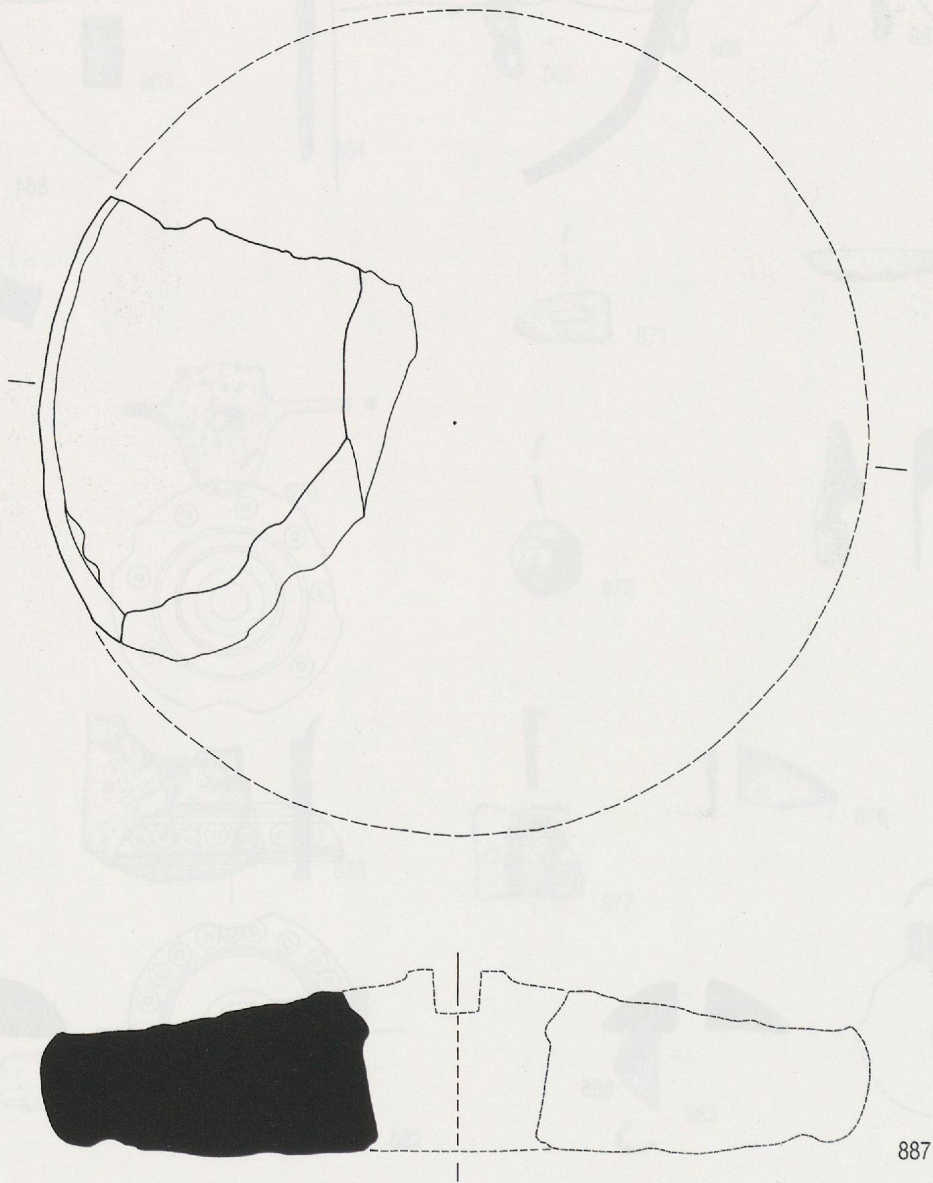

Pl. 64. Montricher VD Châtel d'Arruffens. Bas-Empire. Fragment de meule rotative en granite (887) (éch. 1:4).

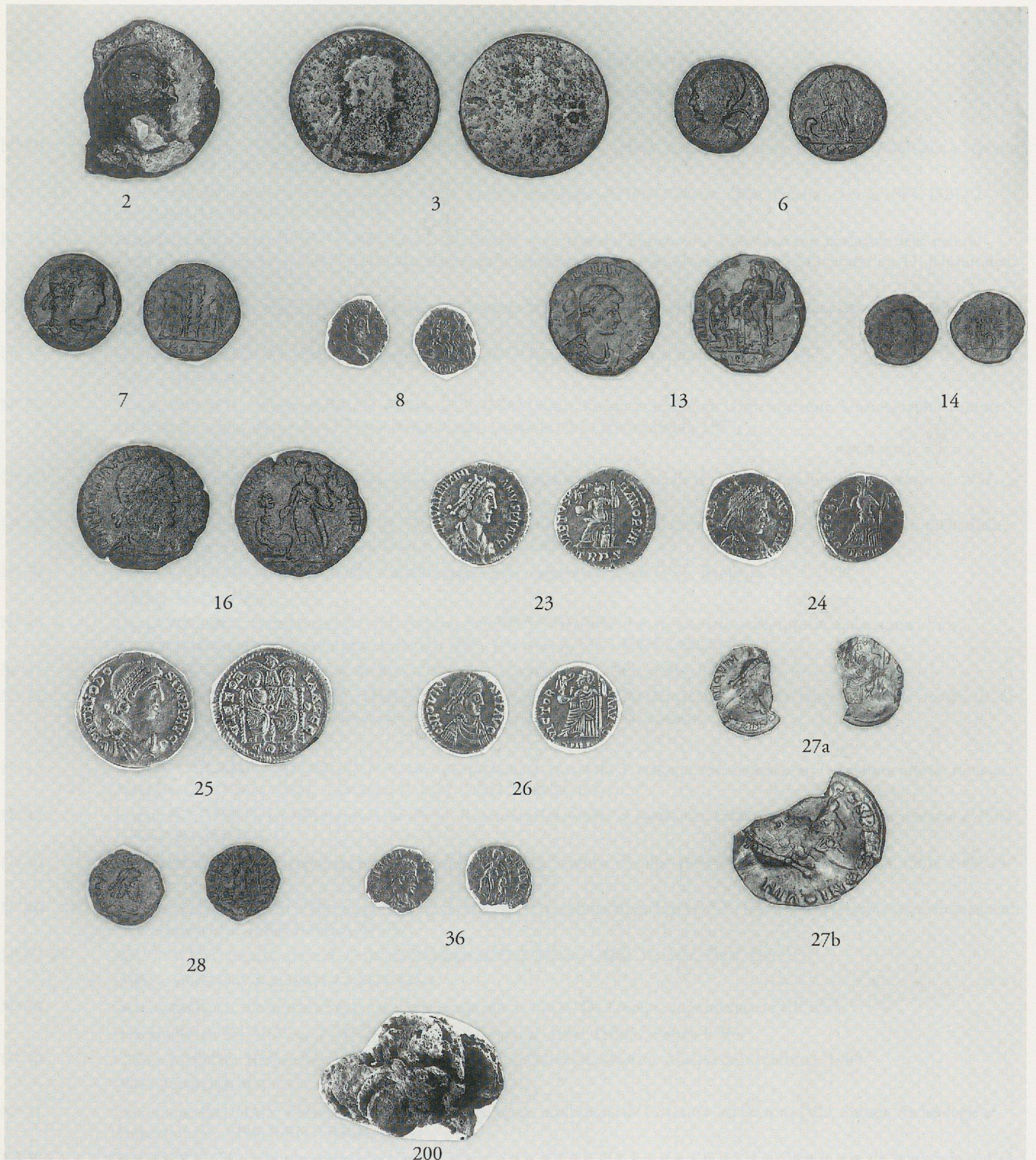

Pl. 65. Montricher VD Châtel d'Arruffens. Choix de monnaies romaines : les numéros correspondent à ceux du catalogue p. 143 (éch. 1:1, sauf 27b, 2:1) (photos Cabinet des médailles du canton de Vaud, Martine Prod'Hom).

