

# Current trends in EDI and X.400

Autor(en): **Greevy, Orla**

Objektyp: **Article**

Zeitschrift: **Technische Mitteilungen / Schweizerische Post-, Telefon- und Telegrafienbetriebe = Bulletin technique / Entreprise des postes, téléphones et télégraphes suisses = Bollettino tecnico / Azienda delle poste, dei telefoni e dei telegrafi svizzeri**

Band (Jahr): **70 (1992)**

Heft 11

PDF erstellt am: **11.09.2024**

Persistenter Link: <https://doi.org/10.5169/seals-874014>

## **Nutzungsbedingungen**

Die ETH-Bibliothek ist Anbieterin der digitalisierten Zeitschriften. Sie besitzt keine Urheberrechte an den Inhalten der Zeitschriften. Die Rechte liegen in der Regel bei den Herausgebern.

Die auf der Plattform e-periodica veröffentlichten Dokumente stehen für nicht-kommerzielle Zwecke in Lehre und Forschung sowie für die private Nutzung frei zur Verfügung. Einzelne Dateien oder Ausdrucke aus diesem Angebot können zusammen mit diesen Nutzungsbedingungen und den korrekten Herkunftsbezeichnungen weitergegeben werden.

Das Veröffentlichen von Bildern in Print- und Online-Publikationen ist nur mit vorheriger Genehmigung der Rechteinhaber erlaubt. Die systematische Speicherung von Teilen des elektronischen Angebots auf anderen Servern bedarf ebenfalls des schriftlichen Einverständnisses der Rechteinhaber.

## **Haftungsausschluss**

Alle Angaben erfolgen ohne Gewähr für Vollständigkeit oder Richtigkeit. Es wird keine Haftung übernommen für Schäden durch die Verwendung von Informationen aus diesem Online-Angebot oder durch das Fehlen von Informationen. Dies gilt auch für Inhalte Dritter, die über dieses Angebot zugänglich sind.

# Current Trends in EDI and X.400

Orla GREEVY, Berne

## 1 Introduction

The aim of this article is to consider the relationship between Electronic Data Interchange (EDI) and X.400, and to closely examine the existing and future efforts to merge these two technologies. Theoretically they are closely related in that EDI and X.400 are both involved with the transfer of messages in a distributed processing environment. EDI, on the one hand, refers to the electronic transfer of messages between computer applications. Similarly, X.400 defines a means of electronic messaging. However, X.400 systems realized to date implement a messaging system providing electronic mail services. Such messages are intended for human interpretation and are, therefore, not directly suitable as a means of transferring EDI messages. The typical EDI message can contain administrative, commercial or trade-related data formatted for easy interpretation by a computer application.

The practice of EDI between business partners has been in existence since the early seventies; therefore, a wealth of experience exists within the established EDI community. This experience has been exploited and used as vital input for the standards bodies involved with defining standards for EDI over X.400. The aspects of X.400 and X.435 will be discussed in detail with respect to the specific communication requirements of EDI.

When considering standardization and EDI, it is necessary to distinguish between the standards for defining the actual data transmitted from the communications protocols used to transmit these messages. This situation has arisen due to the separate evolution paths that EDI and X.400 have taken. EDI solutions have been traditionally developed to meet the needs of a specific industry. This gave rise to various standards for specifying data formats. Much of the recent standardization work for EDI has been concentrated on standardizing the format of data and message types being transferred. As a result, UN/EDIFACT (Electronic Document Interchange for Finance, Administration, Commerce and Transport; ISO 9735) is now emerging as an internationally accepted standard. It is receiving full support and is promoted by many governments and the European Commission.

EDI and X.400 can be viewed as having a synergetic affect on each other. EDI is an obvious OSI upper layer application. Due to marketplace demands, EDI will play

a major role in the establishment and evolution of a worldwide X.400 network. Similarly, an internationally established X.400 service will provide the basis for an international EDI service.

The impact of a global EDI service raises issues that still remain to be resolved if EDI is to succeed at this level. The important questions such as global naming and addressing of EDI applications and auditing are still under discussion.

Interworking of existing EDI solutions to new proposed standard solutions is a high priority issue. The slow evolution process of defining standards and the urgent nature of business requirements has led to a divergence of operational solutions. Many of these solutions are based on proprietary protocols or interim guidelines for using EDI and X.400. These will continue to remain in existence for some years to come.

## 2 Open Systems

Both government and the private sector have recognized the advantages associated with Open Systems. Due to the current marketing trends, the term 'Open System' has been used to refer to systems which do not necessarily conform to its official definition.

*An open system is a system capable of communicating with other open systems by virtue of implementing common international standard protocols [20].*

International standards are being progressed on a worldwide basis by two bodies: The International Standards Organization (ISO) and the Comité Consultatif International Télégraphique et Téléphonique (CCITT). These organizations are responsible for defining standards based on the Open Systems Interconnection (OSI) seven-layer reference model. A primary objective of CCITT recommendations and OSI standards is to specify how distributed information processing tasks are realized when carried out by several cooperating open systems. Communication technology based on the OSI model offers alternatives to vendor-specific network solutions.

The obvious benefits of incorporating Open Systems philosophy into the EDI community is that a step will be made in the direction of achieving an international EDI service.

### 3 Overview of EDI in Industry

A review of the current situation of EDI in industry and its evolutionary process has served as an invaluable source of information to the standards bodies. A high level of interest in the marketplace exists for EDI, in particular for an open EDI solution. Such a solution must be conformant to OSI standards for transmission of data and define one universally accepted means of representing the data to be transmitted.

Early EDI applications were based on bilateral agreements. However, the limitations of this method quickly became apparent as business began to realize the strategic significance of electronic trading on business relationships with a wide range of partners [19]. The communication requirements of EDI naturally extend beyond one-to-one communication paths. As a result, many companies capitalized on this market by offering network services to potential EDI customers. Such companies are commonly referred to as Value-Added and Data Service (VADS) Providers or Value-Added Network Service (VANS) Providers. VADS provide clearing centers for companies performing EDI transactions. Communication in a VADS network (Fig. 1) is usually restricted to a proprietary protocol. With this solution, the EDI communication potential was considerably increased, as the customer had the capability of communicating with all other VADS customers. VADS solutions however, do not provide a user with open EDI, as he is limited to communicating with other customers of the VADS supplier. With the emergence of new universal standardization of messages and communications (OSI X.400), the need for specialized VADSs will be reduced [15]. Public network providers (PTTs) are concentrating on providing services based on internationally standardized protocols.

Traditionally, message standards for EDI were defined within the confines of specific trade organizations and user communities. As with communications aspects, the limitations of this approach are apparent. An open market needs an international message standard in order to ensure interoperability of EDI systems and realize the full potential of EDI. With this in mind, ISO endorsed UN/EDIFACT as an international standard (ISO 9735). EDIFACT standards are also recommended by the Commission for the European Communities (CEC) and by the European Free Trade Association (EFTA) [22]. In Europe, the TEDIS programme encourages the formation of 'EDI associations' and their active participation within the EDIFACT board framework as a most effective means of consolidating user requirements [19].

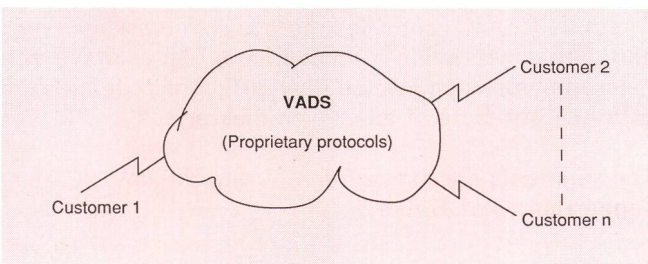

Fig. 1 VADS network

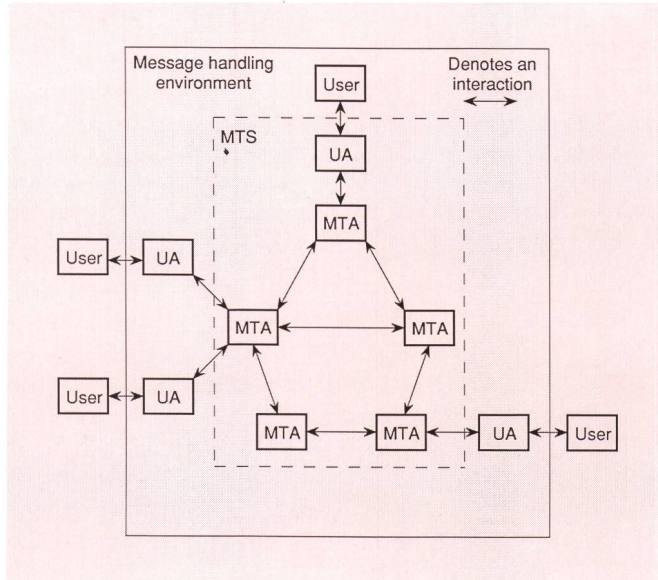

Fig. 2 X.400 (84) MHS functional model

The EDIFACT Board was formed in January 1988 with the aim of coordinating and encouraging the definition of messages based on the UN/EDIFACT standards. EDIFACT defines both the format and the information to be transmitted and its coding. The EDIFACT standardization work is still in progress. While work is almost completed in the area of message syntax, only a few message content types have been developed, to the extent that they are used in practice.

### 4 X.400 – An Application Layer Standard

In 1984, CCITT released the X.400 standards defining an application layer messaging service based on a store-and-forward philosophy. The need for such a messaging service has been reflected response in the marketplace to an X.400-standardized electronic mail system. Its acceptance has been much faster than expected [21]. As a result, there are many X.400 (84) implementations in existence today, as all major computer vendors raced to achieve a leading edge in the X.400 market.

The X.400 (84) approach adopted an architecture which is hierarchically structured into two levels: The Interpersonal Messaging Service (IPMS), which defines electronic mail functions, and the Message Transfer System (MTS), which defines a general mechanism for reliable, connectionless transmission of messages.

The functional model of the X.400 Message Handling System (MHS) defines the components involved in message transfer between users (Fig. 2).

The User Agent (UA) is an application process which makes the services of the MTS accessible to the user. Every UA, thus every user, is identified to the MHS by its address, known in X.400 as the originator/recipient name (or O/R name).

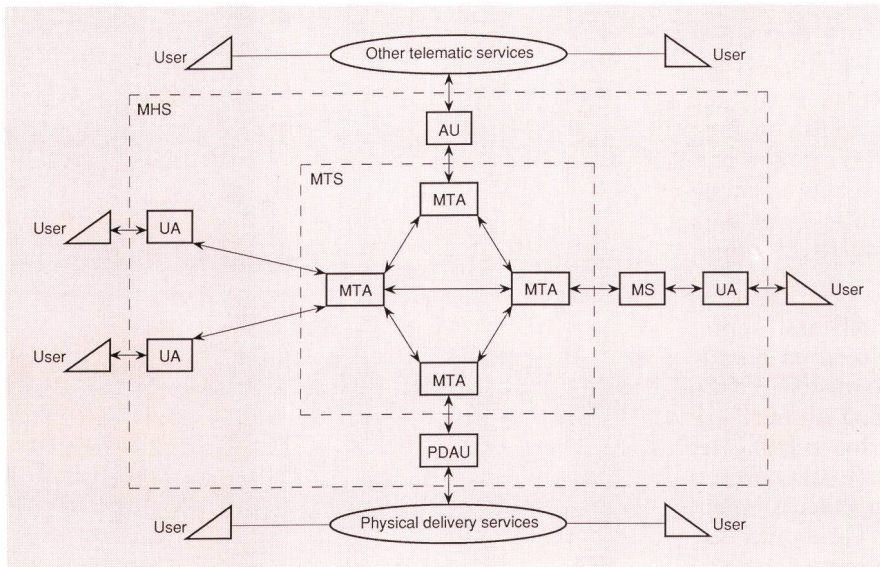

Fig. 3 X.400 (88) MHS functional model

The MTS consists of Message Transfer Agents which relay messages from the UA to the final-destination UA on a store-and-forward basis.

This approach is known as the sublayer approach, as it divides layer 7 of the OSI reference model into two sub-layers: the User Agent Layer (UAL) and the Message Transfer Layer (MTL). This approach is, however, incompatible with the philosophy of the seven-layer OSI reference model. In order to rectify this situation, ISO and CCITT collaborated on the production of a revised version of the CCITT series of recommendations, which were released in 1988 (Fig. 3).

The X.400 (88) series of recommendations are notable at first glance by their significant increase in size. Apart from the alignment with the OSI seven-layer approach, they include many important extensions to the original standards of 1984. The evolution of the X.400 recommendations has been influenced in particular by the accumulated experience of the implementors of the X.400 (84) systems. To encourage and coordinate this input, CCITT introduced the *X.400 Implementor's Guide*. Implementors were asked to report all the inconsistencies and shortcomings they had encountered in the standards [22].

The EDI specific requirements have also been a major influencing factor in the design of extensions in X.400 (88). The X.400 MTS provides the necessary open communication service for transferring EDI messages. The X.400 (88) recognizes the need to consider types of messages other than interpersonal messages. X.400 (88) also includes aspects of the messaging such as autoforwarding, selective retrieval and security issues. Such extensions greatly improve the suitability of X.400 for EDI. Ideally all X.400 systems should conform to the X.400 (88) recommendations, as these are aligned with the OSI reference model and provide many indispensable features for the commercial world. However, in practice, many of the X.400 (88) systems will be extensions of existing X.400 systems. As a result, CCITT have made the ability to interwork with X.400 (84) systems a mandatory requirement for X.400 (88) implementations [23].

## 5 EDI Standards

One significant incompatibility between the X.400 and the EDI technology is the means of representing data to be transmitted. OSI applications use an abstract syntax notation (ASN.1) to code information to be transmitted. Commonly used EDI message standards are purely text-oriented, that is, all data are encoded in ASCII or an equivalent character representation and are transmitted as such [8].

The general acceptance which EDIFACT as received has been a major factor, influencing the design of the PEDI protocol (X.435). It is expected that EDIFACT and X.400 will coexist in the EDI environment. A review of EDIFACT syntax provides an insight into the X.435 protocol.

The EDIFACT message is hierarchically structured. The smallest logical unit of an EDIFACT message is the data element. This corresponds to a document data field. Closely related data elements are grouped into segments. The first data element of a segment specifies its type and thus the nature of the information contained in the segment. A NAD segment, for example, contains the name and address of a business partner. One data element is distinguished from another by means of a separator. Sequences of segments are referred to as segment groups. All segments of a specific document form one EDIFACT message. Several individual messages are combined into a transfer file (Fig. 4).

Message types have also been defined within the EDIFACT standards. The UN Electronic Document Message Directory (EDMD) specifies the possible message types and their construction from segments. An example of a message type is an invoice (INVOIC), which defines the EDIFACT structure of an invoice message.

The segments are defined here, using the INVOIC message example of Figure 5.

UNA The purpose of this segment is to define data delimiters used in the message.

Fig. 4 Structure of an EDIFACT transfer file

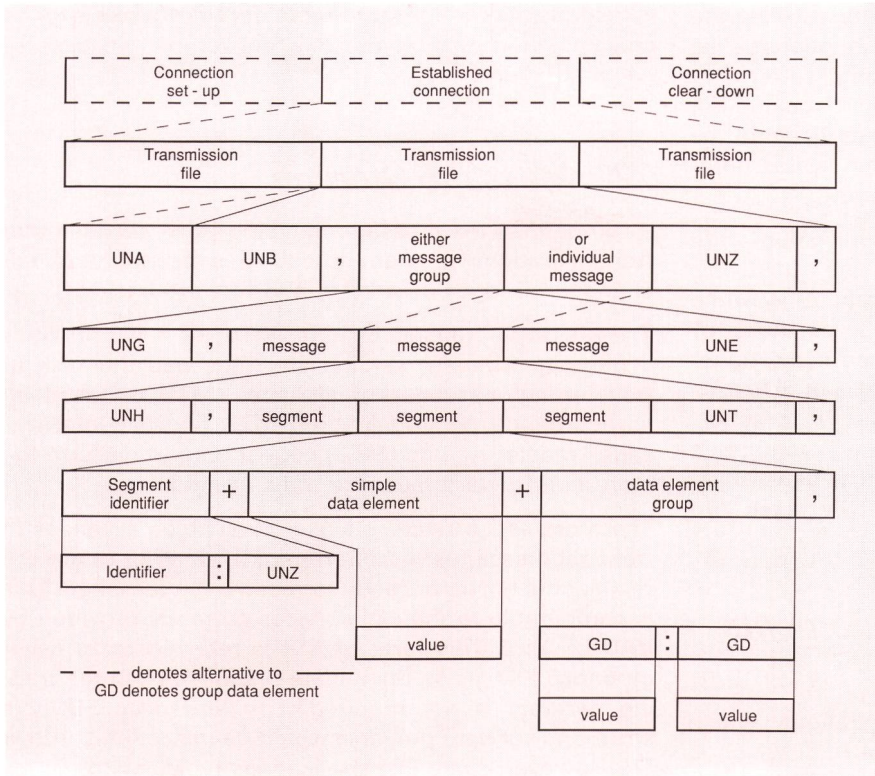

**UNB** This defines a header segment of the transfer file. It contains a statement on the standard and which version is used (UN0A:1 for UN/EDIFACT), the EDIFACT system-specific source and destination addresses, date and time at which the file was generated, and a unique identification.

**UNH** This is the message header segment of an individual message within a transfer file. It contains the originator's reference number, the message type (e.g. INVOIC), and a sequence number.

**BGM** This contains the basic data of the invoice, for example the commercial invoice code (380), the invoice number (999123), and the date of the invoice (900228 = 28th Feb. 1990).

**RFF** This segment contains references to other related documents, eg. the order document.

**NAD** This identifies the name and address segment.

**UNS** This marks the start of the listing of individual +D items of an invoice.

**LIN** This identifies the invoice items. Every item corresponds to one or more segments. It contains the article number, the quantity ordered, price per unit and size of price unit, and the number of price units and the price of the whole item.

**UNS** This segment marks the end of the individual +S items of the invoice.

**TMA** This segment contains the total value of the invoice.

**UNT** This segment marks the end of a message. It contains the message identification and the number of segments.

**UNZ** This segment marks the end segment of a transfer file.

## 6 Message Formats and X.400

In OSI, the Abstract Syntax Notation One (ASN.1) language is used to describe data types. ASN.1 is a 'Backus-Naur-Form'-like context-free language used for

Firma Meier AG Electronic Components Einbahnstrasse 101 8021 Zürich		Herrn Hans Muster Zehnderweg 559 8021 Zürich		
INVOICE Nr. 999123				
Part Number	Description	Quantity	Price	Amount
123-1071	Transistor BC 107 A	20	0.50	10.00
137-3553	Transistor 2n 3553	10	6.40	64.00
118-7400	IC TTL 74LS00	50	0.90	45.00
Postage and Packing				6.50
Total			SFr.	125.50
Payable within 30 days net to Giro account number 80-11111-7				
<pre> UNA: + ? UNB+UN0A:1+126401+126981+900228:1503+REF701' UNH+INV001+INVOIC:1++1' BGM+380+999123+900288' NAD+BY+126981:91++HANS MUSTER+ZEHNDERWEG 559+ZUERICH++8021' NAD+SE+126401:92++FIRMA MEIER AG+EINBAHNSTR 101+ZUERICH++8021' UNS+D LIN++123-1071+20:21:PC+0.5:CA:1+20+10' LIN++137-3553+10:21:PC+6.4:CA:1+10+64' LIN++118-7400+50:21:PC+0.9:CA:1+50+45' LIN++999-9901++++6.5' UNS+S' TMA+125.5' UNT+13+INV001' UNZ+1+REF701' </pre>				

Fig. 5 'INVOIC' message example with its segments

the definition of abstract syntax. It is comparable to the formalism available in programming languages like PASCAL or ADA for the definition of complicated data types. The notation and encoding was first specified in 1984. The X.409 recommendation has since become the most widely accepted method for abstract syntax notation and encoding in the information world [21].

When considering incorporating EDI applications into the OSI world, it might appear logical to use ASN.1 as a means of defining the EDI message format. This would take advantage of X.400-inherent ability to parse ASN.1 syntax. The X.400 User Agents could then make transmission and retrieval decisions on the basis of EDI attributes defined in the message. However, in practical terms, both EDI and X.400 technologies will continue a path of parallel evolution for some time. The general acceptance of the EDIFACT standard must be taken into consideration by the X.400 EDI solution.

## 7 Communications Requirements of EDI

The CCITT X.435 and F.435 recommendations, which were released in 1990, define a protocol PEDI which is specifically designed for the transmission of EDI messages in the X.400 environment. Prior to the release of these recommendations, extensive studies were carried out to assess the suitability of X.400 to fulfil the communications requirements of EDI.

One of the most notable of these studies was commissioned by the UK Department of Trade and Industry as part of the Vanguard Study [11] with the aim of considering the technical relationship between X.400 and EDI. By investigating the market and obtaining information directly from both EDI and X.400 experts and users, the study successfully identified the requirements for modification or extension to the existing standards to enable EDI to take place over X.400. The results of this study served as an important contribution to the CCITT Study Group responsible for defining X.435.

The major requirements identified by this study can be classified under the following headings:

- message transfer
- message storage and retrieval
- interworking
- security and audit
- acknowledgment of receipt
- administration

The aspects of both X.400 and X.435, which satisfy the communication requirements of EDI, are discussed in detail in the following sections.

### 71 Message Transfer

A basic communications requirement of an EDI application is a means of reliably transferring messages between systems.

Both X.400 (84) and X.400 (88) define a means of reliable transfer which fully satisfies this requirement. In X.400 (88), the Reliable Transfer Service Element (RTSE)

is responsible for bulk mode transfer. It provides explicit checkpointing and connection recovery in the case of network failure.

### 72 Message Storage

X.400 defines the message handling (MH) services that Administrations provide to enable subscribers to exchange messages on a store-and-forward basis [1].

The Message Transfer System (MTS) of X.400 provides a message transfer service and thus has the task of transferring messages of all types. MTS is based on asynchronous communication. MTS consists of Message Transfer Agents (MTA) cooperating to perform the store-and-forward message transfer model.

The store-and-forward philosophy enables a sender to transmit messages without regard to whether or not the recipient is online or ready to receive the message. This is comparable to the EDI services currently provided by VADS/VANS. This form of EDI is referred to as asynchronous EDI, as an immediate response from the trading partners is not required. For interactive EDI this store-and-forward principle would be unacceptably slow [7]. However, since EDI applications typically do not require real-time transmission, they are well suited to the store-and-forward nature of X.400 [25].

### 73 Message Retrieval

This requirement identifies the need to store EDI messages before retrieval by the EDI application and to selectively retrieve these messages based on specific message attributes.

The inclusion of the Message Store (MS) in X.400 (88) improves the suitability of X.400 for EDI. It supports message archiving and selective retrieval. It removes the requirement of 24-hour availability of the UA. This is particularly important in the case of a UA running on a stand-alone PC. The MS stores delivered messages and maintains information on these messages. It provides a service of selective retrieval.

X.435 defines a MS satisfying the specific needs of EDI messaging. It maintains EDI attributes, thus facilitating selective retrieval. The EDI MS incorporates the ability to perform autoactions for EDI messages based on a set of predefined EDI attributes.

The EDI-specific autoactions are identified as:

- forwarding with responsibility accepted
- forwarding with responsibility not accepted

## 8 EDI and Security

Due to the sensitive nature of information exchanged in EDI, security is a major issue for consideration. In 1989, as part of the TEDIS programme, the Directorate General of the Commission of European Communities made publicly available the results of an extensive study on security requirements of EDI users.

This study identified possible threats to security, the aspects of security which are prerequisites for EDI and those which are considered important.

Threats:

- loss of service
- disclosure of information
- unauthorized network access by insiders
- fraud
- unauthorized network access by outsiders

Prerequisites:

- user authentication
- message integrity
- confirmation of end-to-end delivery

Important:

- message confidentiality
- network service operational security
- auditability
- network service-harmonized security levels
- nonrepudiable confirmation of receipt

If EDI is to be exploited by more than small closed communities, a standardized approach to security is required. This requirement is realizable if X.400 is adopted as a communication standard for EDI. Harmonized security services, as specified in X.402 and X.411, are an integral part of the X.400 protocol. In addition, X.400 (88) has been expanded to define security aspects of messaging and to secure access management and administration and now provides the necessary security features for EDI messaging. X.435 also identifies EDI-specific security requirements.

## 9 Auditability

The purpose of this security facility is to be able to verify what has passed through the network, so that confidence in the effectiveness of the network security measures can be established [8].

This facility is similar to the concept of an audit. It would appear that creating and maintaining log files is essential for the provision of auditability. Creation of log files is considered a local matter and beyond the scope of the X.400 standards.

Thus, considerable work remains to be done in this important area. Audible logfiles could be provided by VADS or specialized certified agencies.

## 10 Interworking

Interworking aspects are vital for the acceptance and the commercial success of EDI over X.400. It is expected that, as OSI protocols mature, proprietary solutions will eventually be phased out. However, the development of standards is a slow-moving process.

The question of interworking is even applicable within the boundaries of OSI. This is apparent with the incompatibilities between X.400 (84) and X.400 (88). In addition, interim solutions for EDI over X.400 are in existence which are not based on X.435.

## 11 Interim Solutions

In the period preceding the publication of X.435, two radically different approaches for implementing EDI over X.400 emerged. Both approaches involved minimal extensions to existing X.400 implementations. This is intended to emphasize their interim nature. They are commonly referred to as the P2 and P0 approaches, which reflects their respective philosophies for extending X.400 protocols to include an EDI messaging capability.

The P0 approach predominates in the U.S. and is outlined by the National Institute for Standards and Technology (NIST) [28].

The P2 approach, favoured in Europe, is defined by the TEDIS guidelines and approved by CCITT and the European Commission [14].

Care has been taken to design a gateway to interwork both of these approaches, thus enabling EDI communication between European and U.S. trading partners.

### 111 The P0 Approach

The P0 approach to X.400 EDI was directly influenced by U.S. companies solutions to EDI. Their approach was based on a central EDI communications agent responsible for performing EDI communications on behalf of the whole company. It seemed obvious then to base the X.400 on the same philosophy. They chose to incorporate EDI at the MTS layer. As a result, the NIST guidelines recommend that the content of an X.400 envelope (i.e. the P1 protocol) be used to carry the EDI interchange transparently. The form and structure of the EDI interchange is completely transparent to the X.400 messaging system (Fig. 6).

In X.400 (84) an integer is used to define the content type of an MTS envelope. Content type 2 for example refers to an interpersonal message. As NIST had no authority to define content types, they chose 0 to represent the message containing the EDI interchange. For this reason this method is referred to as the P0 approach. However, as it is effectively making use of the P1 protocol to transmit the message, it is more precisely referred to as the P1/0 approach [15].

### 112 The P2 Approach

The P2 interim approach to EDI over X.400 has also been influenced by the practical approach to EDI by European companies. In many cases these companies had been

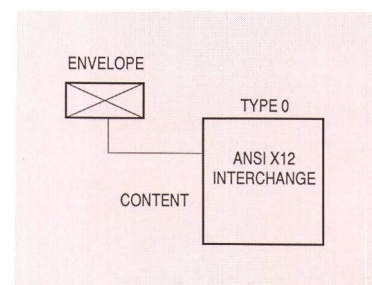

Fig. 6 P1/0 approach

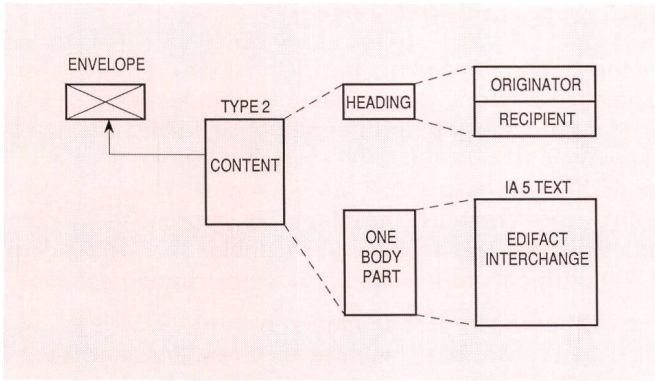

Fig. 7 P2 approach

using proprietary mail systems for EDI; therefore, it seemed logical to incorporate EDI at the IPMS level. The TEDIS guidelines simply recommend that the EDI interchange is transported as the text part of the Interpersonal Message (IPM) content (Fig. 7).

In addition, they specify that one EDI interchange is sent per IPM. The use of P2 service elements in the P2 header is discouraged. The O/R name of the IPM header is the address of the EDI application. Mapping between O/R names and EDI applications is considered by TEDIS as a local issue.

### 113 Shortcomings of the Interim Solutions

Implementations of interim solutions are generally based on X.400 (84). Therefore, the added security extensions of X.400 (88) and the Message Store (MS) are not present. In addition, for both solutions, the EDI in-

terchange is transparent to X.400; therefore, selective retrieval based on EDI attributes is not possible.

## 12 The PEDI Protocol

The X.435 and F.435 recommendations define the PEDI protocol, which is specifically designed for EDI messages. It includes many features not available in the interim P0 and P2 approaches or VADS solutions.

It specifies an EDI message (EDIM) whose structure directly reflects the requirements identified by the VANGUARD Study.

X.435 defines EDI-specific User Agents (EDI-UA) and Message Stores (EDI-MS). The message transfer service used by PEDI is the same as that used by IPM (Fig. 8).

The EDIM consists of a heading and one or more body parts. Only one EDI interchange per EDIM is specified. Other body parts can be used to carry data, such as a drawing related to the interchange (Fig. 9).

The EDI heading contains information required to provide the services such as selective retrieval that more fully satisfy the EDI requirements. The header contains both X.400-specific fields and EDI interchange-specific fields. The EDI-specific fields are copied from the data elements contained in the EDI interchange header segment. The reason for copying data from the EDI interchange header segment to the EDIM heading is to allow the EDI-UA to make decisions on the basis of the data without having to parse the EDI interchange syntax. For convenience, X.435 refers to data elements defined in the EDIFACT-UNB segment. No loss of generality is implied, since other EDI standards have comparable header segments and data elements [8].

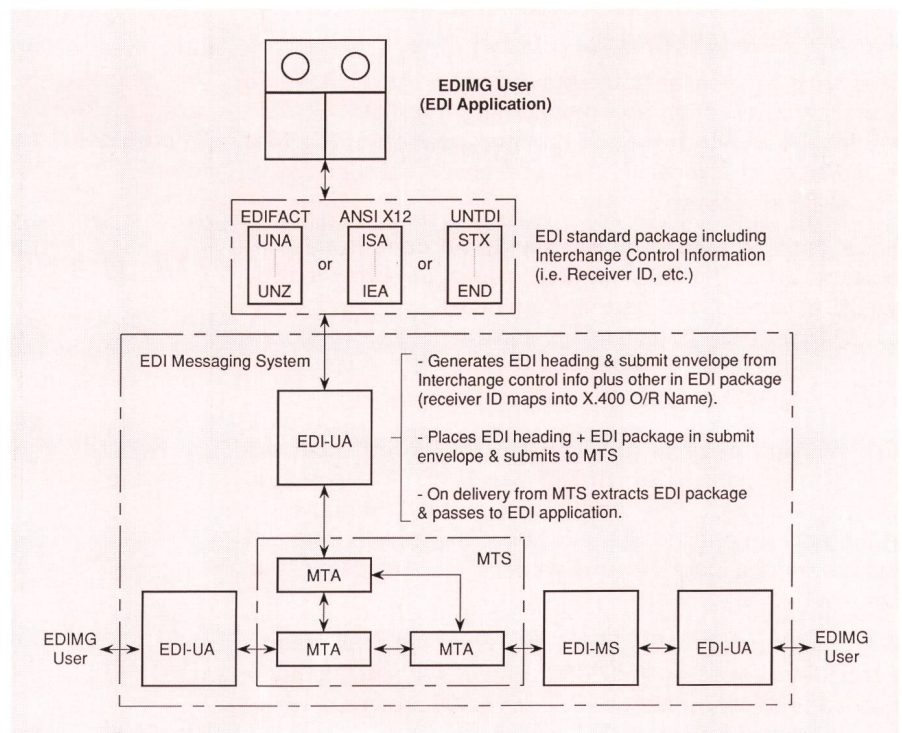

Fig. 8 The EDI messaging system



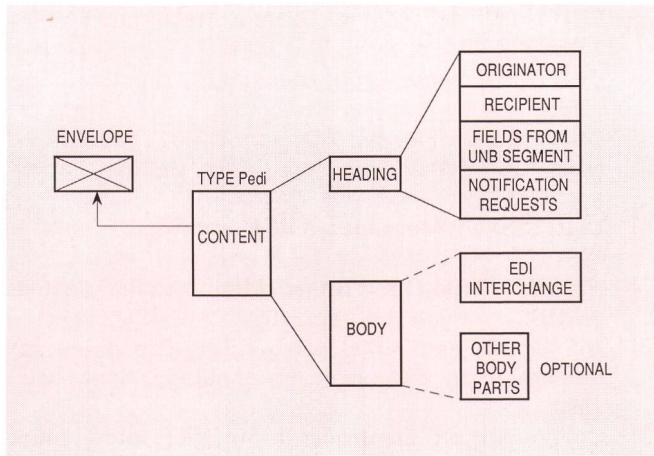

Fig. 9 PEDI approach

### 13 EDI Notifications

EDI notifications (EDIN, Fig. 10) are similar to IPM notifications but consider EDI-specific requirements. Their function is to acknowledge receipt of an EDIM from an EDI recipient to an originator.

### 14 PEDI Security

The PEDI protocol introduces a number of security features that are unique to it and that allow end-to-end security features to be provided even when EDIMS are forwarded.

The X.435 specifications assume that there is a trusted boundary between EDI application and the EDI-UA.

Provision for such security features are considered beyond the scope of X.435.

### 15 Functional Profiles

The CCITT standards contain many options that can be implemented. This degree of flexibility is dangerous, as it can lead to implementors making different decisions on what options should be implemented. The resulting solutions may be conformant to the standards but still be unable to exchange messages. In Europe the Standards Promotion and Application Group (SPAG) and the Comité Européen de Normalisation/Comité Européen de Normalisation Electrotechnique (CEN/CENELEC) are involved with the development of X.400 profiles. Functional profiles specify options in the base standards, which are necessary or desirable, if the specific requirements are to be met and interoperability is to be achieved. NIST is responsible for profiles in the U.S.A. The European Workshop for Open Systems (EWOS) is responsible for the exchange of information between NIST and Europe to ensure profile compatibility.

Draft versions of functional profiles for the X.435 have been published. These profiles classify options of the base standards as optional (O) or mandatory (M).

EWOS A/3331 EDI-UA to EDI-UA profile specifies conformance rules for EDI-UAs and conformance rules for the interchange of PEDI messages.

EWOS A/3332 EDI-UA to MS profile specifies the conformance rules for EDI-MS and for EDI-UA interactions with the EDI-MS.

These functional profiles also approach the subject of interworking X.435-conformant solutions with solutions based on interim approaches to EDI.

## 16 Unresolved Issues

### 161 Naming and Addressing

At present there is no global naming scheme for EDI applications. Each community allocates addresses to EDI trading partners. Names are limited in length by the EDI message syntaxes being used. Therefore, uniqueness is not guaranteed.

The X.400 provides a global addressing scheme called ORAddress. The ORAddress is hierarchically structured and reflects the topographical location of the UA with respect to the MTS.

As the EDI Interchange address is held within the EDI syntax, it is not unique and cannot uniquely identify its trading partners. Existing interim approach to X.400 over EDI map EDI interchange addresses to ORAddresses. This, however, is not a one-to-one mapping.

The VANGUARD Study identified the problem of EDI naming as crucial, requiring immediate attention, if EDI is to succeed at a global level [11].

One possible solution would be to base a global naming scheme in the EANCOM communications standard EAN system. This system defines a numbering system that uniquely identifies an article and its supplier at international level. EAN numbers are an integral part of a common vocabulary used by business partners when exchanging EAN messages [28].

### 162 Realtime Data Interactions

The store-and-forward nature of MHS makes it unsuitable for applications requiring interactive EDI. ISO is currently developing an OSI application layer standard for transaction processing which may well be the basis for OSI support to realtime EDI [11].

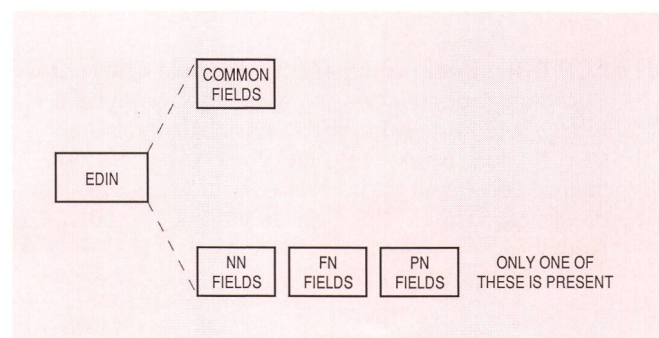

Fig. 10 Key features of an EDIN

## 163 FTAM

The VANGUARD Study briefly mentions the OSI File Transfer Access and Manipulation Protocol (FTAM) as a means of exchanging EDI data [11]. FTAM is an application layer protocol which provides a facility for the transfer and manipulation of files between two systems. However, it does not satisfy the requirements of applications based on message transfer. As previously discussed, the underlying philosophy of the X.400 MTS provides a suitable mechanism for transferring messages between processes. With the introduction of the X.435 protocol, which has been specifically designed to meet the needs of EDI communication, the use of FTAM as a means of exchanging EDI data would be considered as nonconformant.

## 17 Conclusions

The transition to open communications as a means of transmitting EDI messages is essential if EDI is to be successful and an integral part of business transactions. As the X.400 protocol evolves and becomes established worldwide, it becomes increasingly obvious that EDI can exploit this international message handling system. Existing EDI networks and those based on international standards will be required to coexist for some time. The ability to interwork new solutions to existing solutions is a prerequisite for their success and acceptance.

Due to the nature of the data being transmitted, security must be guaranteed. The X.400 (1988) version of the standards and X.435 standards make provisions for secure messaging. Security is also being considered by the EDIFACT Board. Standardization is the only means of ensuring uniform security across the message handling system.

Issues such as naming and addressing on a global basis and billing will be resolved as open EDI matures and becomes established.

X.400 and EDI does not necessarily mean that the VADS market will dry up. On the contrary: the requirement for true added: value in the nature of audit, interworking and message format conversion will increase.

### Bibliography

- [1] CCITT Red Book, volume VIII – Fascicle VIII.7, 'Data Communication Networks, Message Handling Systems', Recommendations X.400–X.430 (1984).
- [2] CCITT Blue Book, volume VIII – Fascicle VIII.7, 'Data Communication Networks, Message Handling Systems', Recommendations X.400–X.420 (1988).
- [3] CCITT EDI Messaging System Recommendation X.435.
- [4] CCITT EDI Messaging Service Recommendation F.435.
- [5] CCITT SG VII Plenary 'EDI and X.400' Theodore H. Myer, CCITT Associate Rapporteur, Geneva, February 1990.
- [6] UN/EDIFACT Messages and Frameworks, October 1991.
- [7] *Rose M. T.* The Open Book: A Practical Perspective on OSI. Prentice Hall Inc., 1990.
- [8] *Hill R.* EDI and X.400 using PEDI: The guide for implementors and users. Technology Appraisals, 1990.
- [9] Colloquium on 'Electronic Information Interchange – X.400 and EDI'. May 1988, Digest No: 1988/72.
- [10] *Bhoania H. P.* X.400 fördert den elektronischen Datenaustausch. Computerworld Schweiz, April 1992.
- [11] VANGUARD EDI and X.400 Study. U. K. Department of Trade and Industry, 1988.
- [12] 'EDITECH'/'TELEMATIK' – Veranstaltung vom 28. Feb. 1991, GD PTT, Bern.
- [13] *Bedere P.* EWOS Working Draft Functional Standard A/3331 EDI-UA to EDI-UA. Bull SA.
- [14] Minutes of TEDIS Meeting on EDI and X.400 Commission of the European Communities, 23 Dec. 1988.
- [15] *Genilloud G.* X.400 MHS: First Steps Toward an EDI Communication Standard. Laboratoire d'informatique.
- [16] *Berger P.* OSI-LAB – Testlabor für OSI-Protokolle. Bern, Techn. Mitt. PTT, 70 (1992) 3, p. 90 and 4, p. 122.
- [17] 'VADS Interworking: A Cloud on the EDI horizon'.
- [18] Meeting User Requirements with X.400.
- [19] EDI in Perspective EUR 1188 3EN Commission of European Communities ECSC-EEC-EAC, Brussels, Luxembourg, 1989.
- [20] U.S. Government Open Systems Interconnection Profile (Gosip), Draft Version 2.0, April 1989.
- [21] *Manros C.-U.* The X.400 Blue Book Companion. Technology Appraisals, 1989.
- [22] X.400 Implementors Guide.
- [23] *Craigie J.* ISO 1000021 – X.400(88): A tutorial for those familiar with X.400(84). Computer Networks and ISDN Systems 16 (1988/89).
- [24] *Gifkins M.* and *Hitchcock D.* The EDI Handbook: Trading in the 1990's. Blenheim Online, 1988.
- [25] *Scott K.* EDI and X.400 Electronic Mail come together. Datamation Communications International, May 1991.
- [26] *Plattner B., Lanz C., Lubich H., Müller M.* and *Walter T.* X.400 Message Handling. Swiss Federal Institute of Technology (ETH), Zürich, Addison Wesley Publishers, 1991.
- [27] *Parfett M.* The EDI Implementor's Handbook. NCC Blackwell Ltd., 1992.
- [28] nEANder – Elektronischer Datenaustausch in der Schweiz. Eine Information der Schweizerischen Artikelcode-Vereinigung (SACV).

## Zusammenfassung *Résumé*

*Aktuelle Entwicklungen im Gebiet des elektronischen Datenaustauschs (EDI) in offenen Systemen nach X.400*

Die Märkte der neunziger Jahre tendieren auf eine Internationalisierung der Geschäftsbeziehungen. Die Bildung des Europäischen Binnenmarkts im Jahre 1992 ist ein deutliches Anzeichen dieser Tendenz. Diese Entwicklung steht als hauptsächliche treibende Kraft hinter der Zusammenführung zweier eingeführter Techniken: dem elektronischen Datenaustausch (EDI) und der Meldungsübermittlung nach X.400. Trotz Ähnlichkeiten in Philosophie und Funktion wurden beide Techniken bis vor wenigen Jahren unabhängig voneinander entwickelt. Nun wurde umfassend untersucht, inwieweit das Meldungsvermittlungssystem nach X.400 in der Lage ist, die Übertragungsforderungen von EDI zu erfüllen, damit die Vorteile offener Systeme auch in der Welt des EDI zum Tragen kommen. Die Normierung ist entscheidend für den weltweiten Erfolg von EDI. Die Ergebnisse vieler Studien in den Bereichen von EDI und X.400 dienen als wichtige Grundlagen für die Studiengruppen der Normierungsgremien. Ein wichtiger Meilenstein bei der Zusammenführung beider Techniken wurde im Juni 1990 mit dem Erscheinen der CCITT-Empfehlungen X.435 und F.435 erreicht, die die Mittel zur Übertragung von EDI-Meldungen über X.400-Netze spezifizieren.

*Développements actuels dans le domaine de l'échange de documents normalisés (EDI) dans les systèmes ouverts selon X.400*

Les années 90 ont été caractérisées par une internationalisation des relations commerciales. La mise en place du marché intérieur européen en 1992 reflète clairement cette tendance. Ce développement est le principal moteur de la confluence de deux techniques déjà introduites: l'échange par voie électronique de documents normalisés (EDI) et la commutation de messages selon X.400. Malgré certaines analogies concernant leur philosophie et leur fonction, ces deux techniques ont été développées il y a peu indépendamment l'une de l'autre. On a maintenant examiné dans quelle mesure le système de commutation de messages selon X.400 était en mesure de satisfaire aux exigences des transmissions EDI, afin de tirer profit des avantages des systèmes ouverts dans l'environnement EDI également. Or, la normalisation joue un rôle décisif pour le succès de l'EDI à l'échelle mondiale. Les résultats de nombreuses études dans les domaines EDI et X.400 servent de bases fondamentales aux groupes d'étude des organismes de normalisation. Au mois de juin 1990, un jalon important a été posé en la matière par la publication des recommandations X.435 et F.435 du CCITT. Ces documents spécifient les moyens permettant de transmettre des messages EDI par le truchement des réseaux X.400.

## Riassunto

*Sviluppi attuali nell'ambito dello scambio elettronico di dati (EDI) nei sistemi aperti secondo X.400*

I mercati degli anni novanta tendono a internazionalizzare i rapporti commerciali. La creazione del mercato unico europeo nel 1992 è un chiaro indizio di questa tendenza. Tale sviluppo è la forza motrice principale che sta dietro alla fusione delle due tecniche introdotte: lo scambio elettronico di dati (EDI) e la trasmissione di messaggi secondo X.400. Benché siano simili per quel che concerne la filosofia e la funzione, fino ad alcuni anni fa le due tecniche sono state sviluppate separatamente. Ora si è voluto esaminare a fondo in che misura il sistema di trasmissione di messaggi secondo X.400 è in grado di soddisfare le condizioni di trasmissione di EDI affinché anche nell'ambito di EDI sia possibile approfittare dei vantaggi di sistemi aperti. La normalizzazione è decisiva per il successo internazionale di EDI. I risultati di molti studi nei settori di EDI e X.400 fungono da basi importanti per i gruppi di studio degli enti di normalizzazione. Un rilevante passo avanti verso la fusione delle due tecniche è stato effettuato nel mese di giugno del 1990 con la pubblicazione delle raccomandazioni CCITT X.435 e F.435 che specificano i mezzi per la trasmissione di messaggi EDI attraverso le reti X.400.

## Summary

*Current trends in EDI and X.400*

The marketplace of the nineties is moving towards the internationalisation of business relationships. This tendency can be observed with the establishment of the Single European Market in 1992. Such developments have been the major driving force leading to the convergence of two established technologies – Electronic Data Interchange (EDI) and X.400 message transfer. Up until recent years both of these technologies were being developed independently of each other, despite similarities in their philosophy and functionality. Extensive work has been carried out to investigate the suitability of the X.400 Message Handling System to satisfy EDI communication requirements in order to incorporate the advantages of Open Systems into the EDI world. Standardization is crucial to the success of EDI on a global basis. The results of many studies within the EDI and X.400 Communities serve as vital input to the Standards Organizations study groups. The publication in June 1990 of the CCITT X.435 and F.435 Recommendations, which specify a means of transmitting EDI Messages over X.400, marks an important merging point for these two technologies.