

Zero Lyapunov exponents of the Hodge bundle

Autor(en): **Forni, Giovanni / Matheus, Carlos / Zorich, Anton**

Objektyp: **Article**

Zeitschrift: **Commentarii Mathematici Helvetici**

Band (Jahr): **89 (2014)**

PDF erstellt am: **11.09.2024**

Persistenter Link: <https://doi.org/10.5169/seals-515677>

Nutzungsbedingungen

Die ETH-Bibliothek ist Anbieterin der digitalisierten Zeitschriften. Sie besitzt keine Urheberrechte an den Inhalten der Zeitschriften. Die Rechte liegen in der Regel bei den Herausgebern. Die auf der Plattform e-periodica veröffentlichten Dokumente stehen für nicht-kommerzielle Zwecke in Lehre und Forschung sowie für die private Nutzung frei zur Verfügung. Einzelne Dateien oder Ausdrucke aus diesem Angebot können zusammen mit diesen Nutzungsbedingungen und den korrekten Herkunftsbezeichnungen weitergegeben werden. Das Veröffentlichen von Bildern in Print- und Online-Publikationen ist nur mit vorheriger Genehmigung der Rechteinhaber erlaubt. Die systematische Speicherung von Teilen des elektronischen Angebots auf anderen Servern bedarf ebenfalls des schriftlichen Einverständnisses der Rechteinhaber.

Haftungsausschluss

Alle Angaben erfolgen ohne Gewähr für Vollständigkeit oder Richtigkeit. Es wird keine Haftung übernommen für Schäden durch die Verwendung von Informationen aus diesem Online-Angebot oder durch das Fehlen von Informationen. Dies gilt auch für Inhalte Dritter, die über dieses Angebot zugänglich sind.

Zero Lyapunov exponents of the Hodge bundle

Giovanni Forni, Carlos Matheus and Anton Zorich

Abstract. By the results of G. Forni and of R. Treviño, the Lyapunov spectrum of the Hodge bundle over the Teichmüller geodesic flow on the strata of Abelian and of quadratic differentials does not contain zeroes even though for certain invariant submanifolds zero exponents are present in the Lyapunov spectrum. In all previously known examples, the zero exponents correspond to those $\mathrm{PSL}(2, \mathbb{R})$ -invariant subbundles of the real Hodge bundle for which the monodromy of the Gauss–Manin connection acts by isometries of the Hodge metric. We present an example of an arithmetic Teichmüller curve, for which the real Hodge bundle does not contain any $\mathrm{PSL}(2, \mathbb{R})$ -invariant, subbundles, and nevertheless its spectrum of Lyapunov exponents contains zeroes. We describe the mechanism of this phenomenon; it covers the previously known situation as a particular case. Conjecturally, this is the only way zero exponents can appear in the Lyapunov spectrum of the Hodge bundle for any $\mathrm{PSL}(2, \mathbb{R})$ -invariant probability measure.

Mathematics Subject Classification (2010). 37D25, 37D40, 32G15.

Keywords. Moduli spaces of Abelian and quadratic differentials, Teichmüller flow, Hodge bundle, Kontsevich–Zorich cocycle, Lyapunov exponents, groups of pseudo-unitary complex matrices.

Contents

1	Introduction	490
1.1	Statement of the results	494
1.2	Lyapunov spectrum of pseudo-unitary cocycles	498
1.3	Outline of the proofs and plan of the paper	498
2	Hodge bundle over invariant suborbifolds in loci of cyclic covers	499
2.1	Splitting of the Hodge bundle over loci of cyclic covers	499
2.2	Construction of $\mathrm{PSL}(2, \mathbb{R})$ -invariant orbifolds in loci of cyclic covers	501
3	Concrete example: the calculations	502
3.1	The $\mathrm{PSL}(2, \mathbb{Z})$ -orbit	502
3.2	Spectrum of Lyapunov exponents	503
4	Closed geodesics on an arithmetic Teichmüller curve	505
4.1	Encoding a Veech group by a graph	506
4.2	Partition of an arithmetic Teichmüller disc into hyperbolic triangles	507

4.3	Encoding an arithmetic Teichmüller curve by a graph	509
5	Irreducibility of the Hodge bundle in the example	511
5.1	Irreducibility of the decomposition	511
5.2	Zariski closure of the monodromy group	514
5.3	Strong irreducibility of the decomposition	516
6	Non-varying phenomenon for certain loci of cyclic covers	518
A	Lyapunov spectrum of pseudo-unitary cocycles: the proofs	521
B	Evaluation of the monodromy representation	525
B.1	Scheme of the construction	525
B.2	Choice of concrete paths and calculation of the monodromy	527
	References	533

1. Introduction

A complex structure on the Riemann surface X of genus g determines a complex g -dimensional space of holomorphic 1-forms $\Omega(X)$ on X , and the Hodge decomposition

$$H^1(X; \mathbb{C}) = H^{1,0}(X) \oplus H^{0,1}(X) \simeq \Omega(X) \oplus \bar{\Omega}(X).$$

The pseudo-Hermitian intersection form

$$\langle \omega_1, \omega_2 \rangle := \frac{i}{2} \int_X \omega_1 \wedge \bar{\omega}_2 \tag{1.1}$$

is positive-definite on $H^{1,0}(X)$ and negative-definite on $H^{0,1}(X)$.

For any linear subspace $V \subset H^1(X, \mathbb{C})$ define its holomorphic and anti-holomorphic parts respectively as

$$V^{1,0} := V \cap H^{1,0}(X)$$

and

$$V^{0,1} := V \cap H^{0,1}(X).$$

A subspace V of the complex cohomology which decomposes as a direct sum of its holomorphic and anti-holomorphic parts, that is, $V = V^{1,0} \oplus V^{0,1}$, will be called a *split* subspace (the case when one of the summands is null is not excluded: a subspace V which coincides with its holomorphic or anti-holomorphic part is also considered as *split*). Clearly, the restriction to any split subspace V of the pseudo-Hermitian form of formula (1.1) is non-degenerate. Note that the converse is, in general, false.

The complex Hodge bundle $H_{\mathbb{C}}^1$ is the bundle over the moduli space \mathcal{M}_g of Riemann surfaces with fiber the complex cohomology $H^1(X, \mathbb{C})$ at any Riemann surface X . The complex Hodge bundle can be pulled back to the moduli space of Abelian or quadratic differentials under the natural projections $\mathcal{H}_g \rightarrow \mathcal{M}_g$ or

$\mathcal{Q}_g \rightarrow \mathcal{M}_g$ respectively. A subbundle V of the complex Hodge bundle is called a *split* subbundle if all of its fibers are split subspaces or, in other terms, if it decomposes as a direct sum of its holomorphic and anti-holomorphic parts.

Let \mathcal{L}_1 be an orbifold in some stratum of unit area Abelian differentials (respectively, in some stratum of unit area meromorphic quadratic differentials with at most simple poles). Throughout this paper we say that such an orbifold is $\mathrm{SL}(2, \mathbb{R})$ -invariant (respectively, $\mathrm{PSL}(2, \mathbb{R})$ -invariant) if it is the support of a Borel probability measure, invariant with respect to the natural action of the group $\mathrm{SL}(2, \mathbb{R})$ (respectively, of the group $\mathrm{PSL}(2, \mathbb{R})$) and ergodic with respect to the Teichmüller geodesic flow. The action of $\mathrm{SL}(2, \mathbb{R})$ (respectively, of $\mathrm{PSL}(2, \mathbb{R})$) on \mathcal{L}_1 lifts to a cocycle on the complex Hodge bundle $H_{\mathbb{C}}^1$ over \mathcal{L}_1 by parallel transport of cohomology classes with respect to the Gauss–Manin connection. This cocycle is called the complex Kontsevich–Zorich cocycle.

It follows from this definition that the pseudo-Hermitian intersection form is $\mathrm{SL}(2, \mathbb{R})$ -equivariant (respectively, $\mathrm{PSL}(2, \mathbb{R})$ -equivariant) under the complex Kontsevich–Zorich cocycle. The complex Kontsevich–Zorich cocycle has a well-defined restriction to the real Hodge bundle $H_{\mathbb{R}}^1$ (the real part of the complex Hodge bundle), called simply the Kontsevich–Zorich cocycle.

By the results of H. Masur [Ma] and of W. Veech [V], the Teichmüller geodesic flow is ergodic on all connected components of all strata in the moduli spaces of Abelian differentials and in the moduli spaces of meromorphic quadratic differentials with at most simple poles with respect to the unique $\mathrm{SL}(2, \mathbb{R})$ -invariant (respectively, $\mathrm{PSL}(2, \mathbb{R})$ -invariant), absolutely continuous, finite measure. By the further results of G. Forni [F1] and of R. Treviño [Tr], it is known that the action of the Teichmüller geodesic flow on the real or complex Hodge bundle over such $\mathrm{SL}(2, \mathbb{R})$ -invariant (respectively, $\mathrm{PSL}(2, \mathbb{R})$ -invariant) orbifolds has only non-zero Lyapunov exponents.

In this paper we continue our investigation on the occurrence of zero Lyapunov exponents for special $\mathrm{PSL}(2, \mathbb{R})$ -invariant orbifolds (see [FMZ1], [FMZ2]). Previous examples of $\mathrm{SL}(2, \mathbb{R})$ -invariant (respectively, $\mathrm{PSL}(2, \mathbb{R})$ -invariant) measures with zero exponents in the Lyapunov spectrum were found in the class of cyclic covers over $\mathbb{C}P^1$ branched exactly at four points (see [BMö], [EKZ1], [F2], [FMZ1] and [FMZ2]). In all of those examples the neutral Oseledets subbundle (that is, the subbundle of the zero Lyapunov exponent in the Oseledets decomposition) is a smooth $\mathrm{SL}(2, \mathbb{R})$ -invariant (respectively, $\mathrm{PSL}(2, \mathbb{R})$ -invariant) split subbundle.

Our main contribution in this paper is the analysis of a cocycle acting on the complex Hodge bundle over a certain $\mathrm{PSL}(2, \mathbb{R})$ -invariant orbifold (which projects onto an arithmetic Teichmüller curve) in the moduli space of holomorphic quadratic differentials in genus four. This particular example was inspired by the work of C. McMullen on the Hodge theory of general cyclic covers [McM3]. It is the first explicit example of a cocycle with the Lyapunov spectrum containing zero exponents such that the neutral Oseledets subbundle, which is by definition flow-invariant, is nevertheless *not* $\mathrm{PSL}(2, \mathbb{R})$ -invariant. In other words, the neutral subbundle in this

example *is not* a pullback of a flat subbundle of the Hodge bundle over the corresponding Teichmüller curve.

In fact, the zero exponents in this new example, as well as those in all previously known ones, can be explained by a simple common mechanism. Conjecturally such a mechanism is completely general and accounts for all zero exponents with respect to any $\mathrm{SL}(2, \mathbb{R})$ -invariant (respectively, $\mathrm{PSL}(2, \mathbb{R})$ -invariant) probability measure on the moduli spaces of Abelian (respectively, quadratic) differentials. It can be outlined as follows. We conjecture that a semisimplicity property holds for the complex Hodge bundle in the spirit of Deligne’s Semisimplicity Theorem. Namely, we conjecture that the restriction of the complex Hodge bundle to any $\mathrm{SL}(2, \mathbb{R})$ -invariant (respectively, $\mathrm{PSL}(2, \mathbb{R})$ -invariant) orbifold as above splits into a direct sum of irreducible $\mathrm{SL}(2, \mathbb{R})$ -invariant (respectively, irreducible $\mathrm{PSL}(2, \mathbb{R})$ -invariant), continuous, split subbundles.¹

The *continuous* vector subbundles in the known examples are, actually, smooth (even analytic, or holomorphic). However, in the context of this paper it is important to distinguish subbundles which are only *measurable* and those which are *continuous*. To stress this dichotomy in the general case we shall always speak about *continuous* subbundles, even when we know that they are smooth (analytic, holomorphic). In particular, a $\mathrm{SL}(2, \mathbb{R})$ -invariant (respectively, $\mathrm{PSL}(2, \mathbb{R})$ -invariant) subbundle of the Hodge bundle is called *irreducible* if it has no non-trivial *continuous* $\mathrm{SL}(2, \mathbb{R})$ -invariant (respectively, $\mathrm{PSL}(2, \mathbb{R})$ -invariant) subbundle. In the special case of subbundles defined over suborbifolds which project onto Teichmüller curves *all* $\mathrm{SL}(2, \mathbb{R})$ -invariant (respectively, $\mathrm{PSL}(2, \mathbb{R})$ -invariant) subbundles are continuous, in fact smooth, since by definition the action of the group on the suborbifold is transitive.

We describe this splitting in our example. In fact, it was observed by M. Möller (see Theorem 2.1 in [Mö]) that whenever the projection of the invariant orbifold \mathcal{L}_1 to the moduli space \mathcal{M}_g is a Teichmüller curve (as in our example) the Deligne Semisimplicity Theorem [DI] implies the existence and uniqueness of the above-mentioned decomposition. The action of the group $\mathrm{SL}(2, \mathbb{R})$ (respectively, $\mathrm{PSL}(2, \mathbb{R})$) on each irreducible, invariant split subbundle of the complex Hodge bundle is a cocycle with values in the group $U(p, q)$ of pseudo-unitary matrices, that is, matrices preserving a quadratic form of signature (p, q) . It is a general result, very likely known to experts, that any $U(p, q)$ -cocycle has at least $|p - q|$ zero Lyapunov exponents (we include a proof of this simple fundamental result in Appendix A).

In the very special case of cyclic covers branched at four points, considered in [BMö], [EKZ2], [FMZ1], [FMZ2], only pseudo-unitary irreducible cocycles of type $(0, 2)$, $(2, 0)$, $(0, 1)$, $(1, 0)$, and $(1, 1)$ arise. In the first four cases the Lyapunov

¹*Added in proof:* this conjecture has been recently proved by S. Filip [Fil2]. Semisimplicity of the Kontsevich–Zorich cocycle on the *real* Hodge bundle had been proved earlier by Avila, Eskin and Möller (see Theorem 1.5 in [AEMö]) after a weaker semisimplicity result, establishing semisimplicity of the algebraic hulls of the cocycle, was proved by Eskin and Mirzahani (see [EMir], Appendix A, also quoted as Theorem 2.1 in [AEMö]).

spectrum of the corresponding invariant irreducible component is null, while in the fifth case there is a symmetric pair of non-zero exponents. The examples which we present in this paper are suborbifolds of the locus of cyclic covers branched at six points. In this case we have a decomposition into two (complex conjugate) continuous components of type $(3, 1)$ and $(1, 3)$. It follows that the zero exponent has multiplicity at least 2 in each component (which is of complex dimension 4). We prove that, in fact, the multiplicity of the zero exponent is exactly 2. Our main example is a suborbifold which projects onto a certain arithmetic Teichmüller curve. In this case we prove that the above-mentioned decomposition is in fact *irreducible*. The irreducibility of the components implies that the complex two-dimensional neutral Oseledets subbundles of both components cannot be $\mathrm{PSL}(2, \mathbb{R})$ -invariant. For general suborbifolds of our locus of cyclic covers branched at six points, it follows from results of [FMZ2] (see in particular Theorem 8 in that paper) that whenever the complex two-dimensional neutral Oseledets subbundles of both components are $\mathrm{PSL}(2, \mathbb{R})$ -invariant, then they are also continuous, in fact smooth. It follows then from our irreducibility result that the neutral Oseledets subbundles are not $\mathrm{PSL}(2, \mathbb{R})$ -invariant on the full locus of cyclic covers branched at six points, which contains our main example. Moreover, recent work of Avila, Matheus and Yoccoz [AMY] suggests that the neutral Oseledets subbundles are also not continuous there.

As in all known examples, our cocycle is non-degenerate, in the sense that the multiplicity of the zero exponent is exactly equal to $|p - q|$. Conjecturally, all cocycles arising from the action of $\mathrm{SL}(2, \mathbb{R})$ (respectively, $\mathrm{PSL}(2, \mathbb{R})$) on the moduli space of Abelian (respectively, quadratic) differentials are non-degenerate in the above sense and are simple, in the sense that all non-zero exponents are simple in every irreducible $\mathrm{SL}(2, \mathbb{R})$ -invariant (respectively, $\mathrm{PSL}(2, \mathbb{R})$ -invariant) continuous component of the complex Hodge bundle. (The simplicity of the Lyapunov spectrum for the canonical invariant measure on the connected components of the strata of Abelian differentials is proved in [AV]; an analogous statement for the strata of *quadratic* differentials for the moment remains conjectural.)

Note that currently one cannot naively apply the Deligne Semisimplicity Theorem to construct an $\mathrm{SL}(2, \mathbb{R})$ -invariant (respectively, a $\mathrm{PSL}(2, \mathbb{R})$ -invariant) splitting of the Hodge bundle over a general invariant suborbifold \mathcal{L} . Even though by recent results of A. Eskin and M. Mirzakhani [EMir] each such invariant suborbifold is an affine subspace in the ambient stratum, it is not known, whether it is a quasiprojective variety or not.²

Note also that the conjectural decomposition of the complex Hodge bundle into irreducible $\mathrm{SL}(2, \mathbb{R})$ -invariant (respectively, $\mathrm{PSL}(2, \mathbb{R})$ -invariant) components might be finer than the decomposition coming from the Deligne Semisimplicity Theorem. The summands in the first (hypothetical) decomposition are irreducible only with

²*Added in proof*: it has been proved recently by S. Filip [Fil1] that all invariant suborbifolds are quasiprojective varieties.

respect to the action by parallel transport *along the* $GL_+(2, \mathbb{R})$ -orbits in \mathcal{L} , or equivalently, *along the leaves of the foliation by Teichmüller discs* in the projectivization $P\mathcal{L}$, while the decomposition of the Hodge bundle provided by the Deligne Semisimplicity Theorem is invariant with respect to the action by parallel transport *of the full fundamental group* of \mathcal{L} . For example, the Hodge bundle $H_{\mathbb{C}}^1$ over the moduli space \mathcal{H}_g of Abelian differentials splits into a direct sum of $(1, 1)$ -tautological subbundle and its $(g - 1, g - 1)$ -orthogonal complement. This splitting is $GL_+(2, \mathbb{R})$ -invariant, but it is by no means invariant under the parallel transport in the directions transversal to the orbits of $GL_+(2, \mathbb{R})$. The only case when the two splittings certainly coincide corresponds to the Teichmüller curves, when the entire orbifold \mathcal{L} is represented by a single orbit of $GL_+(2, \mathbb{R})$.

We conclude the introduction by formulating an outline of the principal conjectures.

Conjecture. *Let \mathcal{L}_1 be a suborbifold in the moduli space of unit area Abelian differentials or in the moduli space of unit area meromorphic quadratic differentials with at most simple poles. Suppose that \mathcal{L}_1 is endowed with a Borel probability measure, invariant with respect to the natural action of the group $SL(2, \mathbb{R})$ (respectively, of the group $PSL(2, \mathbb{R})$) and ergodic with respect to the Teichmüller geodesic flow. The Lyapunov spectrum of the complex Hodge bundle $H_{\mathbb{C}}^1$ over the Teichmüller geodesic flow on \mathcal{L}_1 has the following properties.*

(I) *Let r be the total number of zero entries in the Lyapunov spectrum. By passing, if necessary, to an appropriate finite (possibly ramified) cover $\widehat{\mathcal{L}}_1$ of \mathcal{L}_1 one can decompose the vector bundle induced from the Hodge bundle over $\widehat{\mathcal{L}}_1$ into a direct sum of irreducible $SL(2, \mathbb{R})$ -invariant (respectively, irreducible $PSL(2, \mathbb{R})$ -invariant) continuous split subbundles.³ Denote by (p_i, q_i) the signature of the restriction of the pseudo-Hermitian intersection form to the corresponding split subbundle. Then $\sum_i |p_i - q_i| = r$.*

(II) *By passing, if necessary, to an appropriate finite (possibly ramified) cover $\widehat{\mathcal{L}}_1$ of \mathcal{L}_1 one can decompose the vector bundle induced from the Hodge bundle over $\widehat{\mathcal{L}}_1$ into a direct sum of irreducible $SL(2, \mathbb{R})$ -invariant (respectively, irreducible $PSL(2, \mathbb{R})$ -invariant) continuous split subbundles, such that the nonzero part of the Lyapunov spectrum of each summand is simple.*

1.1. Statement of the results. Let us consider a flat surface S glued from six unit squares as in Figure 1. It is easy to see that this surface has genus zero, and that the flat metric has five conical singularities with the cone angle π and one conical singularity with the cone angle 3π . Thus, the quadratic differential representing the flat surface S belongs to the stratum $\mathcal{Q}(1, -1^5)$ in the moduli space of meromorphic quadratic differentials.

³*Added in proof:* this part of the conjecture in a more precise form has been recently established by S. Filip [Fil2].

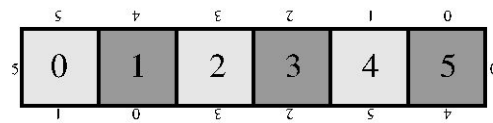

Figure 1. Basic square-tiled surface S in $\mathcal{Q}(1, -1^5)$.

The equation

$$w^3 = (z - z_1) \dots (z - z_6) \tag{1.2}$$

defines a Riemann surface \hat{X} of genus four, and a triple cover $p: \hat{X} \rightarrow \mathbb{CP}^1$, $p(w, z) = z$. The cover p is ramified at the points z_1, \dots, z_6 of \mathbb{CP}^1 and at no other points. By placing the ramification points z_1, \dots, z_6 at the single zero and at the five poles of the flat surface S as in Figure 1 we induce on \hat{X} a flat structure, thus getting a square-tiled surface \hat{S} . It is immediate to check that \hat{S} belongs to the stratum $\mathcal{Q}(7, 1^5)$ of holomorphic quadratic differentials in genus four.

Let us consider the corresponding arithmetic Teichmüller curve $\hat{\mathcal{T}} \subset \mathcal{M}_4$ and the Hodge bundle over it. The following theorem, announced in [FMZ2], Appendix B, summarizes the statement of Proposition 3.1 and of Corollary 5.1.

Theorem 1. *The Lyapunov spectrum of the real Hodge bundle $H_{\mathbb{R}}^1$ with respect to the geodesic flow on the arithmetic Teichmüller curve $\hat{\mathcal{T}}$ is*

$$\left\{ \frac{4}{9}, \frac{4}{9}, 0, 0, 0, 0, -\frac{4}{9}, -\frac{4}{9} \right\}.$$

The real Hodge bundle $H_{\mathbb{R}}^1$ over $\hat{\mathcal{T}}$ does not have any nontrivial $\text{PSL}(2, \mathbb{R})$ -invariant subbundles.

It follows from the above theorem that the neutral Oseledets subbundle E_0 over $\hat{\mathcal{T}}$ is not $\text{PSL}(2, \mathbb{R})$ -invariant. It seems likely that it is also not continuous.

Note that the cyclic group $\mathbb{Z}/3\mathbb{Z}$ acts naturally on any Riemann surface \hat{X} as in (1.2) by deck transformations of the triple cover $p: \hat{X} \rightarrow \mathbb{CP}^1$. In coordinates this action is defined as

$$T : (z, w) \mapsto (z, \zeta w), \tag{1.3}$$

where $\zeta = e^{2\pi i/3}$. Thus, the complex Hodge bundle $H_{\mathbb{C}}^1$ splits over the locus of cyclic covers (1.2) into a direct sum of two flat subbundles (that is, vector subbundles invariant under the parallel transport with respect to the Gauss–Manin connection):

$$H_{\mathbb{C}}^1 = \mathcal{E}(\zeta) \oplus \mathcal{E}(\zeta^2), \tag{1.4}$$

where $\mathcal{E}(\zeta)$, $\mathcal{E}(\zeta^2)$ are the eigenspaces of the induced action of the generator T of the group of deck transformations.

The above Theorem 1 has an equivalent formulation in terms of the complex Hodge bundle, which summarizes the statements of Proposition 3.1 and of Proposition 5.2 below.

Theorem 2. *The complex Hodge bundle $H_{\mathbb{C}}^1$ over the arithmetic Teichmüller curve $\widehat{\mathcal{T}}$ does not have any non-trivial $\mathrm{PSL}(2, \mathbb{R})$ -invariant complex subbundles other than $\mathcal{E}(\zeta)$ and $\mathcal{E}(\zeta^2)$. The Lyapunov spectrum of each of the subbundles $\mathcal{E}(\zeta)$, $\mathcal{E}(\zeta^2)$ with respect to the geodesic flow on $\widehat{\mathcal{T}}$ is*

$$\left\{ \frac{4}{9}, 0, 0, -\frac{4}{9} \right\}.$$

Actually, there is nothing special about the arithmetic Teichmüller curve $\mathcal{T} \subset \mathcal{Q}(1, -1^5)$ considered above. By taking any $\mathrm{PSL}(2, \mathbb{R})$ -invariant suborbifold $\mathcal{L} \subseteq \mathcal{Q}(1, -1^5)$ we can construct a cyclic cover (1.2) for each flat surface S in \mathcal{L} placing the six ramification points at the zero and at the five poles of the quadratic differential. We get the induced quadratic differential on the resulting cyclic cover. In this way we get a $\mathrm{PSL}(2, \mathbb{R})$ -invariant suborbifold $\widehat{\mathcal{L}} \subseteq \mathcal{Q}(7, 1^5)$. By construction, it has the same properties as \mathcal{L} , namely, it is endowed with a Borel probability measure, invariant with respect to the natural action of the group $\mathrm{PSL}(2, \mathbb{R})$ and ergodic with respect to the Teichmüller geodesic flow. (See the end of Section 2 for a generalization of this construction.) Let $\widehat{\mathcal{Z}}$ denote the suborbifold of all cyclic covers branched at six points, namely, the suborbifold obtained by the above construction in the case $\mathcal{L} = \mathcal{Q}(1, -1^5)$ (see also [FMZ2], Appendix B).

Theorem 3. *The complex Hodge bundle $H_{\mathbb{C}}^1$ over the invariant orbifold $\widehat{\mathcal{L}}$ decomposes into the direct sum of two $\mathrm{PSL}(2, \mathbb{R})$ -invariant, continuous split subbundles $H_{\mathbb{C}}^1 = \mathcal{E}(\zeta) \oplus \mathcal{E}(\zeta^2)$ of signatures $(1, 3)$ and $(3, 1)$ respectively. The Lyapunov spectrum of each of the subbundles $\mathcal{E}(\zeta)$, $\mathcal{E}(\zeta^2)$ with respect to the Teichmüller geodesic flow on $\widehat{\mathcal{L}}$ is*

$$\left\{ \frac{4}{9}, 0, 0, -\frac{4}{9} \right\}.$$

The only difference between the more general Theorem 3 and the previous one, treating the particular case $\widehat{\mathcal{L}} = \widehat{\mathcal{T}}$, is that now we do not claim irreducibility of the subbundles $\mathcal{E}(\zeta)$, $\mathcal{E}(\zeta^2)$ for all invariant orbifolds $\widehat{\mathcal{L}}$ as above. Theorem 3 follows from Theorem 4 below and from Proposition 6.2.

Note that the stratum $\mathcal{Q}(1, -1^5)$ is naturally isomorphic to the stratum $\mathcal{H}(2)$. Thus, the classification of C. McMullen [McM1] describes all $\mathrm{PSL}(2, \mathbb{R})$ -invariant suborbifolds in $\mathcal{Q}(1, -1^5)$: they are represented by an explicit infinite series of suborbifolds corresponding to arithmetic Teichmüller curves, by an explicit infinite series of suborbifolds corresponding to non-arithmetic Teichmüller curves and by the entire stratum. By the way, note that the subbundles $\mathcal{E}(\zeta)$, $\mathcal{E}(\zeta^2)$ of the Hodge bundle over

the invariant suborbifold $\widehat{\mathcal{Z}} \subset \mathcal{Q}(7, 1^5)$ (induced from the entire stratum $\mathcal{Q}(1, -1^5)$) are irreducible: indeed, this follows from Theorem 2 as $\widehat{\mathcal{T}} \subset \widehat{\mathcal{Z}}$. Theorem 3 confirms the Conjecture stated in the introduction for all resulting $\mathrm{PSL}(2, \mathbb{R})$ -invariant suborbifolds (up to the irreducibility of the decomposition in the case of suborbifolds $\widehat{\mathcal{L}} \neq \widehat{\mathcal{T}}, \widehat{\mathcal{Z}}$).

As proved in [FMZ2], Appendix B, Theorem 8, from Theorem 1 and Theorem 3 above and from Theorem 3 of [FMZ2] we can derive the following result.

Corollary 1.1. *If the neutral Oseledets subbundle E_0 of the Kontsevich–Zorich cocycle over the invariant suborbifold $\widehat{\mathcal{L}}$ is $\mathrm{PSL}(2, \mathbb{R})$ -invariant, then it is continuous, in fact smooth. In particular, since $\widehat{\mathcal{T}} \subset \widehat{\mathcal{Z}}$, the subbundle E_0 is not almost everywhere $\mathrm{PSL}(2, \mathbb{R})$ -invariant over the suborbifold $\widehat{\mathcal{Z}}$ endowed with the canonical measure.*

A. Avila, C. Matheus and J.-C. Yoccoz [AMY] have recently proved that indeed E_0 is also not continuous over the suborbifold $\widehat{\mathcal{Z}}$.

Note that a Riemann surface X , or a pair given by a Riemann surface and an Abelian or quadratic differential, might have a nontrivial automorphism group. This automorphism group is always finite. The fiber of the Hodge bundle $H_{\mathbb{C}}^1$ over the corresponding point x of the moduli space is defined as the quotient of $H^1(X, \mathbb{C})$ by the corresponding finite group G_x of induced linear automorphisms. In other words, the bundle $H_{\mathbb{C}}^1$ is an *orbifold vector bundle*, in the sense that it is a *fibered space* H over a base M such that the fiber H_x over any $x \in M$ is the quotient $H_x = V_x/G_x$ of a vector space V_x over a finite subgroup G_x of the group $\mathrm{Aut}(V_x)$ of linear automorphisms of V_x .

Since the Hodge bundle $H_{\mathbb{C}}^1$ is an orbifold vector bundle, the complex Kontsevich–Zorich cocycle is an example of an *orbifold linear cocycle* on an orbifold vector bundle H over a flow T_t on M , i.e., a flow F_t on H such that the restrictions $F_t: H_x \rightarrow H_{T_t x}$ are well defined and are projections of linear maps $\widehat{F}_t: V_x \rightarrow V_{T_t x}$. Note that such linear maps are only defined up to precomposition with the action of elements of G_x on V_x and postcomposition with the action of elements of $G_{T_t x}$ on $V_{T_t x}$.

In this paper we always work within the locus of cyclic covers. For any generic cyclic cover x as in (1.2) the automorphism group is isomorphic to the cyclic group $\mathbb{Z}/3\mathbb{Z}$. The induced action on the subspaces $\mathcal{E}_x(\zeta)$ and $\mathcal{E}_x(\zeta^2)$ is particularly simple: the induced group G_x of linear automorphisms acts by multiplication by the complex numbers ζ^k for $k = 0, 1, 2$ (we recall that $\zeta = e^{2\pi i/3}$). This implies that any complex vector subspace of $\mathcal{E}_x(\zeta)$ or $\mathcal{E}_x(\zeta^2)$ is invariant. The elements of the monodromy representations of the bundles $\mathcal{E}(\zeta)$ and $\mathcal{E}(\zeta^2)$, hence in particular the restrictions of the Kontsevich–Zorich cocycle to those bundles, are thus given by linear maps defined only up to composition with the maps $\zeta^k \mathrm{Id}$, that is, up to multiplication by ζ^k , for $k = 0, 1, 2$,

1.2. Lyapunov spectrum of pseudo-unitary cocycles. Consider an invertible transformation (or a flow) ergodic with respect to a finite measure. Let U be a log-integrable cocycle over this transformation (flow) with values in the group $U(p, q)$ of pseudo-unitary matrices. The Oseledets Theorem (i.e. the multiplicative ergodic theorem) can be applied to complex cocycles. Denote by $\lambda_1, \dots, \lambda_{p+q}$ the corresponding Lyapunov spectrum.

Theorem 4. *The Lyapunov spectrum of a pseudo-unitary cocycle U is symmetric with respect to the sign change and has at least $|p - q|$ zero exponents.*

In other words, the Lyapunov spectrum of an integrable cocycle with the values in the group $U(p, q)$ of pseudo-unitary matrices has the form

$$\lambda_1 \geq \dots \geq \lambda_r \geq 0 = \dots = 0 \geq -\lambda_r \geq \dots \geq -\lambda_1,$$

where $r = \min(p, q)$. In particular, if $r = 0$, the spectrum is null.

This theorem might be known to experts, and, in any case, the proof is completely elementary. For the sake of completeness, it is given in Appendix A.

1.3. Outline of the proofs and plan of the paper. We begin by recalling in Section 2.1 some basic properties of cyclic covers. In Section 2.2 we construct plenty of more general $\mathrm{PSL}(2, \mathbb{R})$ -invariant orbifolds in loci of cyclic covers.

By applying results of C. McMullen [McM3], we then show in Section 2.1 that in the particular case of the arithmetic Teichmüller disc $\widehat{\mathcal{T}}$ defined in Section 1.1, the splitting $H_{\mathbb{C}}^1 = \mathcal{E}(\zeta) \oplus \mathcal{E}(\zeta^2)$ of the complex Hodge bundle over $\widehat{\mathcal{T}}$ decomposes the corresponding cocycle over the Teichmüller geodesic flow on $\widehat{\mathcal{T}}$ into the direct sum of complex conjugate $U(3, 1)$ and $U(1, 3)$ -cocycles. By Theorem 4 the Lyapunov spectrum of each of the two cocycles has the form

$$\{\lambda, 0, 0, -\lambda\},$$

with nonnegative λ . Since the two cocycles are complex conjugate, their Lyapunov spectra coincide. Hence, the Lyapunov spectrum of real and complex Hodge bundles over $\widehat{\mathcal{T}}$ has the form

$$\{\lambda, \lambda, 0, 0, 0, 0, -\lambda, -\lambda\}.$$

To compute λ we construct in Section 3.1 the $\mathrm{PSL}(2, \mathbb{Z})$ -orbit of the square-tiled surface \widehat{S} . This orbit is very small: it contains only two other square-tiled surfaces. Knowing the cylinder decompositions of the resulting square-tiled surfaces in the $\mathrm{PSL}(2, \mathbb{Z})$ -orbit of \widehat{S} , we apply a formula from [EKZ2] for the sum of the positive Lyapunov exponents of the Hodge bundle over the corresponding arithmetic Teichmüller disc $\widehat{\mathcal{T}}$ to get the explicit value $\lambda = 4/9$. This computation is performed in Section 3.2. (In Section 6 we present an alternative, more general, way to compute Lyapunov exponents in similar situations.)

In Section 5 we check the irreducibility of the subbundles $\mathcal{E}(\zeta)$ and $\mathcal{E}(\zeta^2)$ essentially by hands. Note that the monodromy representation of the subbundles $\mathcal{E}(\zeta)$ and $\mathcal{E}(\zeta^2)$ factors through the action of the Veech group of $\widehat{\mathcal{F}}$. We encode the action of the group $\mathrm{PSL}(2, \mathbb{Z})$ on the orbit of \widehat{S} by a graph Γ associating oriented edges to the basic transformations

$$h = \begin{pmatrix} 1 & 1 \\ 0 & 1 \end{pmatrix} \quad \text{and} \quad r = \begin{pmatrix} 0 & -1 \\ 1 & 0 \end{pmatrix}.$$

The resulting graph Γ is represented at Figure 5, p. 531. We choose a basis of homology on every square-tiled surface in the $\mathrm{PSL}(2, \mathbb{Z})$ -orbit of \widehat{S} and associate to every oriented edge of the graph the corresponding monodromy matrix. Any closed path on the graph defines the free homotopy type of the corresponding closed path on the Teichmüller curve $\widehat{\mathcal{F}}$. The monodromy along such path on $\widehat{\mathcal{F}}$ can be calculated as the product of matrices associated to edges of the graph in the order following the path on the graph. In Proposition 5.1 we construct two explicit closed paths and show that the induced monodromy transformations cannot have common invariant subspaces. This implies the irreducibility claims in Theorems 1 and 2. The evaluation of the monodromy representation is outlined in Appendix B. However, in order to avoid overloading the paper, we have left the details to Appendix B of the extended version [FMZ3] of this paper.

Following a suggestion of M. Möller, we compute in Section 5.2 the Zariski closure of the monodromy group of $\mathcal{E}(\zeta)$ (Lemma 5.2) and prove in Proposition 5.3 the *strong irreducibility*⁴ of $\mathcal{E}(\zeta)$ and of $\mathcal{E}(\zeta^2)$.

In Section 6 we prove the non-varying phenomenon for certain $\mathrm{PSL}(2, \mathbb{R})$ -invariant loci of cyclic covers. Namely, we show that the sum of the Lyapunov exponents is the same for any $\mathrm{PSL}(2, \mathbb{R})$ -invariant suborbifold in such loci.

Finally, in Appendix A we discuss some basic facts concerning linear algebra of pseudo-unitary cocycles and prove Theorem 4.

2. Hodge bundle over invariant suborbifolds in loci of cyclic covers

2.1. Splitting of the Hodge bundle over loci of cyclic covers. Consider a collection of n pairwise-distinct points $z_i \in \mathbb{C}$. The equation

$$w^d = (z - z_1) \dots (z - z_n) \tag{2.1}$$

defines a Riemann surface \widehat{X} , and a cyclic cover $p: \widehat{X} \rightarrow \mathbb{CP}^1$, $p(w, z) = z$. Consider the canonical generator T of the group $\mathbb{Z}/d\mathbb{Z}$ of deck transformations; let

$$T^*: H^1(X; \mathbb{C}) \rightarrow H^1(X; \mathbb{C})$$

⁴I.e., the irreducibility of lifts of $\mathcal{E}(\zeta)$ and $\mathcal{E}(\zeta^2)$ to any finite (possibly ramified) cover of $\widehat{\mathcal{F}}$.

be the induced action in cohomology. Since $(T^*)^d = \text{Id}$, the eigenvalues of T^* belong to a subset of $\{\zeta, \dots, \zeta^{d-1}\}$, where $\zeta = \exp\left(\frac{2\pi i}{d}\right)$. We excluded the root $\zeta^0 = 1$ since any cohomology class invariant under deck transformations would be a pullback of a cohomology class on $\mathbb{C}P^1$, and $H^1(\mathbb{C}P^1) = 0$.

For $k = 1, \dots, d - 1$ set

$$\mathcal{E}(\zeta^k) := \text{Ker}(T^* - \zeta^k \text{Id}) \subseteq H^1(X; \mathbb{C}). \quad (2.2)$$

Write

$$\mathcal{E}^{1,0}(\zeta^k) := \mathcal{E}(\zeta^k) \cap H^{1,0}$$

and

$$\mathcal{E}^{0,1}(\zeta^k) := \mathcal{E}(\zeta^k) \cap H^{0,1}.$$

Since a generator T of the group of deck transformations respects the complex structure, it induces a linear map

$$T^* : H^{1,0}(X) \rightarrow H^{1,0}(X).$$

This map preserves the pseudo-Hermitian form (1.1) on $H^{1,0}(X)$. This implies that T^* is a unitary operator on $H^{1,0}(X)$, and hence $H^{1,0}(X)$ admits a splitting into a direct sum of eigenspaces of T^* ,

$$H^{1,0}(X) = \bigoplus_{k=1}^{d-1} \mathcal{E}^{1,0}(\zeta^k). \quad (2.3)$$

The latter observation also implies that for any $k = 1, \dots, d - 1$ one has $\mathcal{E}(\zeta^k) = \mathcal{E}^{1,0}(\zeta^k) \oplus \mathcal{E}^{0,1}(\zeta^k)$. The vector bundle $\mathcal{E}^{1,0}(\zeta^k)$ over the locus of cyclic covers (2.1) is a holomorphic subbundle of $H_{\mathbb{C}}^1$.

The decomposition

$$H^1(X; \mathbb{C}) = \bigoplus \mathcal{E}(\zeta^k),$$

is preserved by the Gauss–Manin connection, which implies that the complex Hodge bundle $H_{\mathbb{C}}^1$ over the locus of cyclic covers (2.1) splits into a direct sum of the subbundles $\mathcal{E}(\zeta^k)$ invariant with respect to the parallel transport of the Gauss–Manin connection.

Theorem (C. McMullen). *The signature of the intersection form on $\mathcal{E}(\zeta^{-k})$ is given by*

$$(p, q) = ([n(k/d) - 1], [n(1 - k/d) - 1]). \quad (2.4)$$

In particular,

$$\dim \mathcal{E}(\zeta^k) = \begin{cases} n - 2 & \text{if } d \text{ divides } kn, \\ n - 1 & \text{otherwise.} \end{cases} \quad (2.5)$$

By applying these general results to the particular cyclic cover (1.2), we see that $H_{\mathbb{C}}^1 = \mathcal{E}(\zeta) \oplus \mathcal{E}(\zeta^2)$, where the signature of the intersection form on $\mathcal{E}(\zeta)$ is (3, 1) and on $\mathcal{E}(\zeta^2) = \overline{\mathcal{E}(\zeta)}$ is (1, 3).

Bibliographical remarks. Cyclic covers over $\mathbb{C}P^1$ branched at four points were used by I. Bouw and M. Möller in [BMö] to construct new series of nonarithmetic Teichmüller curves. Similar cyclic covers were independently used by G. Forni [F2] and then by G. Forni and C. Matheus [FM] to construct arithmetic Teichmüller curves with completely degenerate spectrum of the Lyapunov exponents of the Hodge bundle with respect to the geodesic flow. The monodromy of the Hodge bundle is explicitly described in these examples by C. Matheus and J.-C. Yoccoz [MY]. More general arithmetic Teichmüller curves corresponding to cyclic covers over $\mathbb{C}P^1$ branched at four points are studied in [FMZ1]. The Lyapunov spectrum of the Hodge bundle over such arithmetic Teichmüller curves is explicitly computed in [EKZ1]. More generally, Abelian covers are studied in this context by A. Wright [W]. Our consideration of cyclic covers as in (2.1) is inspired by the paper of C. McMullen [McM3], where he studies the monodromy representation of the braid group in the Hodge bundle over the locus of cyclic covers.

For details on geometry of cyclic covers see the original papers of I. Bouw [B1] and [B2] and of J. K. Koo [Koo], as well as the recent paper of A. Elkin [EI] citing the first three references as a source.

2.2. Construction of $\mathrm{PSL}(2, \mathbb{R})$ -invariant orbifolds in loci of cyclic covers. Suppose for simplicity that d divides n , where n and d are the integer parameters in equation (2.1). The reader can easily extend the considerations below to the remaining case.

Let \mathcal{L} be a $\mathrm{PSL}(2, \mathbb{R})$ -invariant suborbifold in some stratum $\mathcal{Q}(m_1, \dots, m_k, -1^l)$ in the moduli space of quadratic differentials with at most simple poles on $\mathbb{C}P^1$. For any such invariant orbifold \mathcal{L} and for any couple of integers (d, n) we construct a new $\mathrm{PSL}(2, \mathbb{R})$ -invariant suborbifold $\widehat{\mathcal{L}}$ such that the Riemann surfaces underlying the flat surfaces from $\widehat{\mathcal{L}}$ belong to the locus of cyclic covers (2.1). The construction is performed as follows.

Let $S = (\mathbb{C}P^1, q) \in \mathcal{L}$. In the simplest case, when the total number $k + l$ of zeroes and poles of the meromorphic quadratic differential q on $\mathbb{C}P^1$ coincides with the number n of ramification points, one can place the points z_1, \dots, z_n exactly at the zeroes and poles of the corresponding quadratic differential q . (Here we assume that d divides n , so that the cyclic cover as in (2.1) is not ramified at infinity.) Consider the induced quadratic differential p^*q on the cyclic cover \widehat{X} . By applying this operation to every flat surface $S \in \mathcal{L}$, we get the promised orbifold $\widehat{\mathcal{L}}$. Since by assumption \mathcal{L} is $\mathrm{PSL}(2, \mathbb{R})$ -invariant, the induced orbifold $\widehat{\mathcal{L}}$ is also $\mathrm{PSL}(2, \mathbb{R})$ -invariant, and in the simplest case, when $k + l = n$, we get $\dim \widehat{\mathcal{L}} = \dim \mathcal{L}$. In particular, starting with a Teichmüller curve, we get a Teichmüller curve.

In the concrete example from Section 1.1 we start with an arithmetic Teichmüller curve \mathcal{T} corresponding to the stratum $\mathcal{Q}(1, -1^5)$. Placing the points z_1, \dots, z_6 at the single zero and at the five poles of each flat surface S in \mathcal{T} we get an arithmetic Teichmüller curve $\widehat{\mathcal{T}}$ corresponding to the stratum $\mathcal{Q}(7, 1^5)$. By construction, $\widehat{\mathcal{T}}$ belongs to the locus of cyclic covers (1.2).

The latter construction can be naturally generalized to the case when $k + l \neq n$.

When $\mathcal{P}\mathcal{L}$ is a nonarithmetic Teichmüller curve, the construction can be modified by placing the points z_1, \dots, z_n at all possible subcollections of n distinct *periodic points*; see [GHS] for details.

The construction can be generalized further. Let \mathcal{L}_1 be a $\mathrm{PSL}(2, \mathbb{R})$ -invariant suborbifold of some stratum $\mathcal{Q}_1(m_1, \dots, m_k, -1, \dots, -1)$ in genus zero. Fix a subset Σ in the ordered set with multiplicities $\{m_1, \dots, m_k, -1, \dots, -1\}$; let j be the cardinality of Σ . For each flat surface $S = (\mathbb{CP}^1, q)$ in \mathcal{L} , consider all possible cyclic covers as in (2.1) such that the points z_1, \dots, z_j run over all possible configurations of the zeroes and poles corresponding to the subset Σ , and the remaining points z_{j+1}, \dots, z_n run over all possible configurations of $n - j$ distinct regular points in S . Considering for each configuration a quadratic differential p^*q on the resulting cyclic cover \widehat{X} , we construct a $\mathrm{PSL}(2, \mathbb{R})$ -invariant suborbifold $\widehat{\mathcal{L}}$ of complex dimension $(\dim \mathcal{L} + n - j)$.

Of course, the proof that when \mathcal{L}_1 is endowed with a Borel probability measure, invariant with respect to the natural action of the group $\mathrm{PSL}(2, \mathbb{R})$ and ergodic with respect to the Teichmüller geodesic flow, the new suborbifold $\widehat{\mathcal{L}}_1$ is also endowed with a $\mathrm{PSL}(2, \mathbb{R})$ -invariant measure satisfying the same properties, requires in general case $n - j > 0$ some extra work (see, for example, the paper [EMkMr] in this spirit).

3. Concrete example: the calculations

In this section we treat in all details the example from Section 1.1.

3.1. The $\mathrm{PSL}(2, \mathbb{Z})$ -orbit. It is an exercise (left to the reader) to verify that the $\mathrm{PSL}(2, \mathbb{Z})$ -orbit of the square-tiled surface S of Figure 1 has the structure presented in Figure 2 below. For historical reasons, the initial surface S is denoted by S_3 there.

Convention 1. For typographical reasons, we are forced to use a peculiar orientation as in Figure 2 and in all remaining figures in this paper. The notions “horizontal” and “vertical” correspond to this “landscape orientation”: “horizontal” means “parallel to the x -axes” and “vertical” means “parallel to the y -axes”. Under this convention, the leftmost surface S_3 of Figure 2 has a single *horizontal* cylinder of height 1 and width 6.

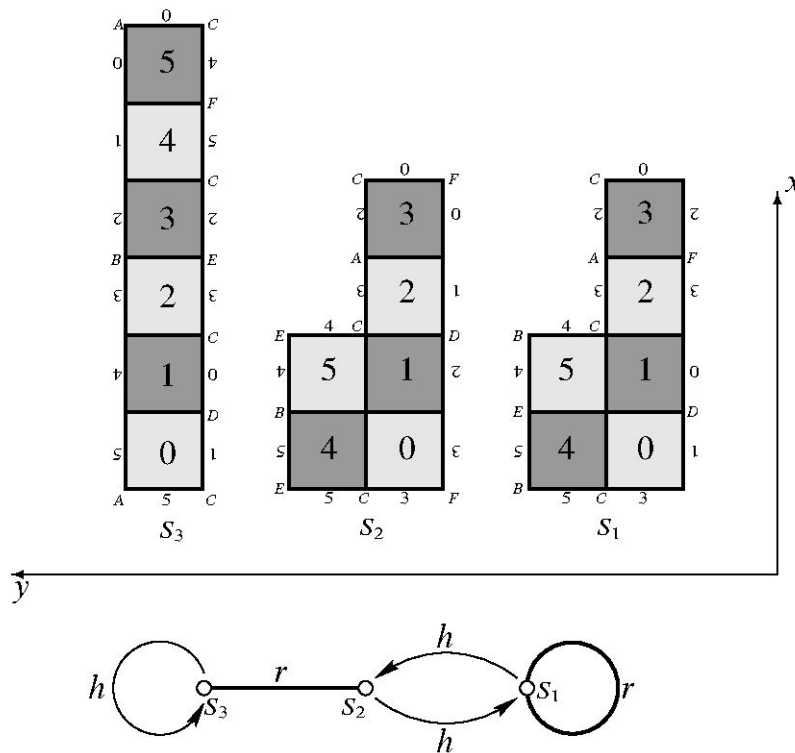

Figure 2. $PSL(2, \mathbb{Z})$ -orbit of S .

The three square-tiled surfaces $\hat{S}_1, \hat{S}_2, \hat{S}_3$ in the $PSL(2, \mathbb{Z})$ -orbit of $\hat{S} = \hat{S}_3$ are presented in Figure 5. This figure also shows how the surfaces $\hat{S}_1, \hat{S}_2, \hat{S}_3$ are related by the basic transformations

$$h = \begin{pmatrix} 1 & 1 \\ 0 & 1 \end{pmatrix} \quad \text{and} \quad r = \begin{pmatrix} 0 & -1 \\ 1 & 0 \end{pmatrix}$$

given by the action of $PSL(2, \mathbb{Z})$ on the flat surfaces $\hat{S}_1, \hat{S}_2, \hat{S}_3$.

3.2. Spectrum of Lyapunov exponents

Lemma 3.1. *The sum of the nonnegative Lyapunov exponents of the Hodge bundle H^1 with respect to the geodesic flow on $\hat{\mathcal{F}}$ is equal to $8/9$.*

Proof. By the formula for the sum of Lyapunov exponents of the subbundle $H_{\mathbb{R}}^1 = H_+^1$ from [EKZ2] one has

$$\lambda_1 + \dots + \lambda_g = \frac{1}{24} \sum_{j=1}^n \frac{d_j(d_j + 4)}{d_j + 2} + \frac{\pi^2}{3} \cdot c_{\text{area}}(\hat{\mathcal{F}}) \tag{3.1}$$

where the Siegel–Veech constant for the corresponding arithmetic Teichmüller disc $\widehat{\mathcal{F}}$ is computed as

$$c_{\text{area}}(\widehat{\mathcal{F}}) = \frac{3}{\pi^2} \cdot \frac{1}{\text{card}(\text{PSL}(2, \mathbb{Z}) \cdot \widehat{\mathcal{S}})} \sum_{\widehat{\mathcal{S}}_i \in \text{PSL}(2, \mathbb{Z}) \cdot \widehat{\mathcal{S}}} \sum_{\substack{\text{horizontal} \\ \text{cylinders } \text{cyl}_{ij} \\ \text{such that} \\ \widehat{\mathcal{S}}_i = \sqcup \text{cyl}_{ij}}} \frac{h_{ij}}{w_{ij}},$$

In our case $\widehat{\mathcal{F}} \subset \mathcal{Q}(7, 1^5)$, so the first summand in (3.1) gives

$$\frac{1}{24} \sum_{j=1}^n \frac{d_j(d_j + 4)}{d_j + 2} = \frac{1}{24} \left(\frac{7 \cdot 11}{9} + 5 \cdot \frac{1 \cdot 5}{3} \right) = \frac{19}{27}.$$

Observing the cylinder decompositions of the three surfaces in the $\text{PSL}(2, \mathbb{Z})$ -orbit of the initial square-tiled cyclic cover, we get:

$$\frac{\pi^2}{3} \cdot c_{\text{area}}(\widehat{\mathcal{F}}) = \frac{1}{3} \left(\frac{1}{18} + 2 \left(\frac{1}{12} + \frac{1}{6} \right) \right) = \frac{5}{27}.$$

Thus, taking the sum of the two terms in (3.1) we get

$$\lambda_1 + \dots + \lambda_4 = \frac{19}{27} + \frac{5}{27} = \frac{8}{9}$$

□

Consider the $\text{PSL}(2, \mathbb{R})$ -invariant subbundles $\mathcal{E}(\zeta)$, $\mathcal{E}(\zeta^2)$ of the Hodge bundle $H_{\mathbb{C}}^1$ over $\widehat{\mathcal{F}}$ as in (2.2). Note that in our case we have $H_{\mathbb{C}}^1 = \mathcal{E}(\zeta) \oplus \mathcal{E}(\zeta^2)$.

Proposition 3.1. *The Lyapunov spectrum of the real and complex Hodge bundles $H_{\mathbb{R}}^1$ and $H_{\mathbb{C}}^1$ with respect to the geodesic flow on the arithmetic Teichmüller curve $\widehat{\mathcal{F}}$ is*

$$\left\{ \frac{4}{9}, \frac{4}{9}, 0, 0, 0, 0, -\frac{4}{9}, -\frac{4}{9} \right\}.$$

The Lyapunov spectrum of each of the subbundles $\mathcal{E}(\zeta)$, $\mathcal{E}(\zeta^2)$ with respect to the geodesic flow on $\widehat{\mathcal{F}}$ is

$$\left\{ \frac{4}{9}, 0, 0, -\frac{4}{9} \right\}.$$

Proof. Note that the vector bundles $\mathcal{E}(\zeta)$ and $\mathcal{E}(\zeta^2)$ are complex conjugate. Hence, their Lyapunov spectra coincide.

The pseudo-Hermitian Hodge bilinear form on $H_{\mathbb{C}}^1$ is preserved by the Gauss–Manin connection. By the theorem of C. McMullen cited at the end of Section 2.1, the

signature of its restriction to $\mathcal{E}(\zeta)$, $\mathcal{E}(\zeta^2)$ equals to $(3, 1)$ and $(1, 3)$ respectively. Thus, the restriction of the cocycle to $\mathcal{E}(\zeta)$, $\mathcal{E}(\zeta^2)$ lies in $U(3, 1)$ and $U(1, 3)$ respectively. Hence, by Theorem 4 the spectrum of each of $\mathcal{E}(\zeta)$ and $\mathcal{E}(\zeta^2)$ has the form

$$\{\lambda, 0, 0, -\lambda\},$$

where $\lambda \geq 0$. Since $H_{\mathbb{C}}^1 = \mathcal{E}(\zeta) \oplus \mathcal{E}(\zeta^2)$, the spectrum of Lyapunov exponents of the Hodge bundle $H_{\mathbb{C}}^1$ is the union of spectra of $\mathcal{E}(\zeta)$ and of $\mathcal{E}(\zeta^2)$. Since the Lyapunov spectrum of $H_{\mathbb{R}}^1$ coincides with the one of $H_{\mathbb{C}}^1$ we conclude that the spectrum of $H_{\mathbb{R}}^1$ is

$$\{\lambda, \lambda, 0, 0, 0, 0, -\lambda, -\lambda\}.$$

By Lemma 3.1 we get $\lambda = 4/9$. □

Recall that the Oseledets subspace (subbundle) E_0 (the one associated to the zero exponents) is called *neutral Oseledets subspace (subbundle)*.

Proposition 3.2. *The Kontsevich–Zorich cocycle over $\widehat{\mathcal{T}}$ acts by isometries on the neutral Oseledets subbundle E_0 of each of the bundles $\mathcal{E}(\zeta)$, $\mathcal{E}(\zeta^2)$. In other words, the restriction of the pseudo-Hermitian form to the subbundle E_0 of each of the bundles $\mathcal{E}(\zeta)$, $\mathcal{E}(\zeta^2)$ is either positive-definite or negative-definite.*

Proof. The Kontsevich–Zorich cocycle over $\widehat{\mathcal{T}}$ on $\mathcal{E}(\zeta)$, respectively, on $\mathcal{E}(\zeta^2)$, is a $U(3, 1)$, respectively, a $U(1, 3)$, cocycle. Moreover, by Proposition 3.1, the dimension of the corresponding neutral Oseledets subspaces is $2 = 3 - 1 = |1 - 3|$. By Lemma A.5 below, this implies that the Kontsevich–Zorich cocycle acts by isometries along the neutral Oseledets subspace. □

Remark 3.1. This proposition was motivated by a question of Y. Guivarch to the authors.

We prove in Section 6 a non-varying phenomenon similar to the one proved by D. Chen and M. Möller in [ChMö] for strata in lower genera: certain invariant loci of cyclic covers share the same sum of the Lyapunov exponents.

4. Closed geodesics on an arithmetic Teichmüller curve

In this section we describe basic facts concerning the geometry of a general arithmetic Teichmüller curve. We do not claim originality: these elementary facts are in part already described in the literature (see [Hr], [HL1], [HS], [MMöY], [McM2], [Schm1], [Schm2], [Y], [Zm], [Z1] and references there); in part widely known in folklore concerning square-tiled surfaces (as in recent experiments [DxL]); in part

they can be extracted from the broad literature on coding of geodesics on surfaces of constant negative curvature (see, for example, [Da] and [Ser] and references there).

Consider a general square-tiled surface S_0 . Throughout this section we assume that the flat structure on S_0 is defined by a quadratic differential no matter whether it is a global square of an Abelian differential or not. In particular, we deviate from the traditional convention and always consider the Veech group $\Gamma(S_0)$ of S_0 as a subgroup of $\mathrm{PSL}(2, \mathbb{R})$, and never as a subgroup of $\mathrm{SL}(2, \mathbb{R})$.

We use the same notation \mathcal{T} for the arithmetic Teichmüller curve defined by S_0 and for the corresponding hyperbolic surface with cusps.

Note that, when working with geodesic flows, in some situations one has to consider the points of the unit tangent bundle while in the other situations the points of the base space. In our concrete example with arithmetic Teichmüller curves, the orbit $\mathrm{PSL}(2, \mathbb{R}) \cdot S_0 \subset \mathcal{Q}_g$ of a square-tiled surface S_0 in the moduli space of quadratic differentials \mathcal{Q}_g plays the role of the unit tangent bundle to the arithmetic Teichmüller curve $\mathcal{T} \subset \mathcal{M}_g$ in the moduli space \mathcal{M}_g of curves. The corresponding projection is defined by “forgetting” the quadratic differential:

$$\mathcal{Q}_g \ni S = (C, q) \mapsto C \in \mathcal{M}_g.$$

4.1. Encoding a Veech group by a graph. Recall that $\mathrm{PSL}(2, \mathbb{Z})$ is isomorphic to the group with two generators h and r satisfying the relations

$$r^2 = \mathrm{id} \quad \text{and} \quad (hr)^3 = \mathrm{id}. \quad (4.1)$$

As generators r and h one can chose matrices

$$h = \begin{pmatrix} 1 & 1 \\ 0 & 1 \end{pmatrix} \quad \text{and} \quad r = \begin{pmatrix} 0 & -1 \\ 1 & 0 \end{pmatrix}.$$

Given an irreducible square-tiled surface S_0 defined by a quadratic differential, construct the following graph \mathbb{G} . Its vertices are in a bijection with the elements of the orbit $\mathrm{PSL}(2, \mathbb{Z}) \cdot S_0$. Its edges are partitioned in two types. Edges of “ r -type” are not oriented. Edges of “ h -type” are oriented. The edges are naturally constructed as follows. Each vertex $S_i \in \mathbb{G}$ is joined by the edge of the r -type with the vertex represented by the square-tiled surface $r \cdot S_i$. Each vertex $S_i \in \mathbb{G}$ is also joined by the oriented edge of the “ h -type” with the vertex $h \cdot S_i$, where the edge is oriented from S_i to $h \cdot S_i$.

By construction, the graph \mathbb{G} with marked vertex S_0 is naturally identified with the coset $\mathrm{PSL}(2, \mathbb{Z}) / \Gamma(S_0)$, where $\Gamma(S_0)$ is the Veech group of the square-tiled surface S_0 . (Irreducibility of S_0 implies that $\Gamma(S_0)$ is indeed a subgroup of $\mathrm{PSL}(2, \mathbb{Z})$.)

The structure of the graph carries complete information about the Veech group $\Gamma(S_0)$. Namely, any path on the graph \mathbb{G} composed from a collection of its edges defines the corresponding word in “letters” h, h^{-1}, r . Any *closed* path starting at S_0

naturally defines an element of the Veech group $\Gamma(S_0) \subseteq \text{PSL}(2, \mathbb{Z})$. Reciprocally, any element of $\Gamma(S_0)$ represented as a word in generators h, h^{-1}, r defines a closed path starting at S_0 . Two closed homotopic paths, with respect to the homotopy in \mathbb{G} with the fixed base point S_0 , define the same element of the Veech group $\Gamma(S_0)$. Clearly, the resulting map

$$\pi_1(\mathbb{G}, S_0) \rightarrow \Gamma(S_0) \subseteq \text{PSL}(2, \mathbb{Z}) \tag{4.2}$$

is a group homomorphism, and even epimorphism.

For any flat surface $S = g \cdot S_0$ in the $\text{PSL}(2, \mathbb{R})$ -orbit $\text{PSL}(2, \mathbb{R}) \cdot S_0$ of the initial square-tiled surface S_0 the Veech group $\Gamma(S)$ is conjugated to the Veech group of S_0 , namely, $\Gamma(S) = g \cdot \Gamma(S_0) \cdot g^{-1}$. One can construct an analogous graph \mathbb{G}_S for S which would be isomorphic to the initial one. The only change would concern the representation of the edges in $\text{PSL}(2, \mathbb{R})$: the edges of the h -type would be represented now by the elements ghg^{-1} and the edges of the r -type would be represented by the elements rg^{-1} .

Note that by a result of P. Hubert and S. Lelièvre [HL2], in general, $\Gamma(S_0)$ is not a congruence subgroup.

One can formalize the properties of the graph \mathbb{G} as follows:

- (i) Each vertex of \mathbb{G} has valence three or four, where one valence is represented by an outgoing edge of the “ h -type”, another one – by an incoming edge of the “ h -type”; the remaining one or two valences are represented by an r -edge or an r -loop respectively;
- (ii) The path $hrhrhr$ (where we follow the orientation of each h -edge) starting from any vertex of the graph \mathbb{G} is closed.

4.2. Partition of an arithmetic Teichmüller disc into hyperbolic triangles. Let us consider the modular curve (modular surface)

$$\mathcal{M}\mathcal{O}\mathcal{D} = \text{PSO}(2, \mathbb{R}) \backslash \text{PSL}(2, \mathbb{R}) / \text{PSL}(2, \mathbb{Z}),$$

and its canonical fundamental domain in the upper half plane, namely the hyperbolic triangle (with angles $0, \pi/3, \pi/3$)

$$\{z \mid \text{Im } z > 0\} \cap \{z \mid -1/2 \leq \text{Re } z \leq 1/2\} \cap \{z \mid |z| \geq 1\}. \tag{4.3}$$

Any arithmetic Teichmüller curve \mathcal{F} has a natural structure of a (possibly ramified) cover over the modular curve, and, thus, it is endowed with the natural partition by isometric triangles as above. We accurately say “partition” instead of “triangulation” because of the following subtlety: the side of the triangle represented by the circle arc in the left picture of Figure 3 might be folded in the middle point B and glued to itself, as it happens, for example, already for the modular surface $\mathcal{M}\mathcal{O}\mathcal{D}$. The vertices and the sides of this partition define a graph $\check{\mathbb{G}}$ embedded into the compactified surface

$\bar{\mathcal{T}}$, where we apply the following convention: each side of the partition, which is bent in the middle and glued to itself, is considered as a loop of the graph, see Figures 3 and 4. In particular, the middle point of such side is *not* a vertex of the graph $\check{\mathbb{G}}$.

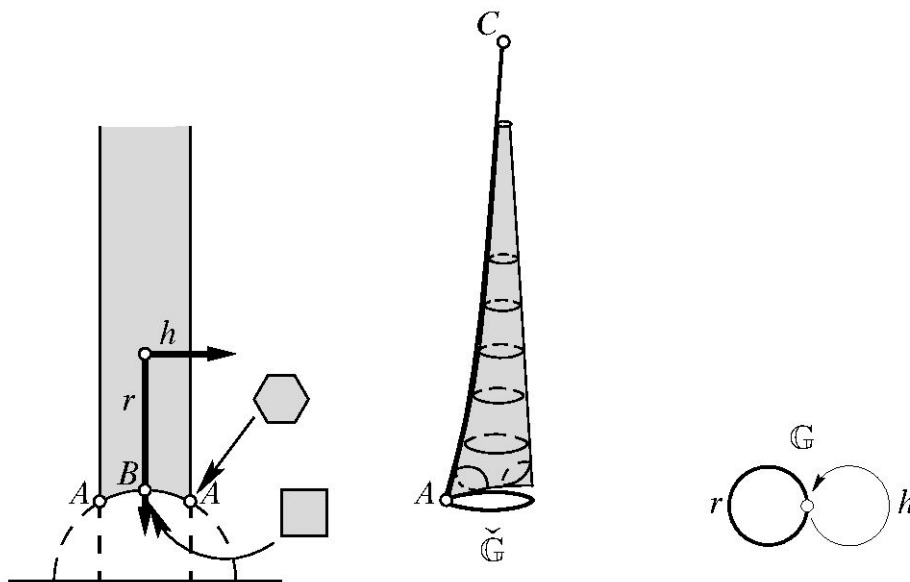

Figure 3. Modular surface, its fundamental domain, and associated graphs \mathbb{G} and $\check{\mathbb{G}}$.

The degree of the cover $\mathcal{T} \rightarrow \mathcal{M}\mathcal{O}\mathcal{D}$ equals to the cardinality of the $\text{PSL}(2, \mathbb{Z})$ -orbit of the initial square-tiled surface S_0 ,

$$\text{deg}(\mathcal{T} \rightarrow \mathcal{M}\mathcal{O}\mathcal{D}) = \text{card}(\text{PSL}(2, \mathbb{Z}) \cdot S_0). \tag{4.4}$$

The cover $\mathcal{T} \rightarrow \mathcal{M}\mathcal{O}\mathcal{D}$ might be ramified over two special points of $\mathcal{M}\mathcal{O}\mathcal{D}$. The first possible ramification point is the point B (having coordinate i); it corresponds to the flat torus glued from the unit square, see Figure 3. The second possible ramification point is the point A represented by the identified corners $e^{-i\pi/3}$ and $e^{i\pi/3}$ of the hyperbolic triangle (4.3). The latter point corresponds to the flat torus glued from the regular hexagon.

Any preimage of the point B (see Figure 3) is either regular or has ramification degree two. In the first case the preimage is a conical singularity of the hyperbolic surface \mathcal{T} with the cone angle π (as for the modular surface $\mathcal{M}\mathcal{O}\mathcal{D}$ itself); in the latter case it is a regular point of \mathcal{T} .

Any preimage of the point A (see Figure 3) is either regular or has the ramification degree three. In the first case the preimage is a conical singularity of the hyperbolic surface \mathcal{T} with the cone angle $2\pi/3$ (as for the modular surface $\mathcal{M}\mathcal{O}\mathcal{D}$ itself); in the latter case it is a regular point of \mathcal{T} .

For each of the two special points of the base surface $\mathcal{M}\mathcal{O}\mathcal{D}$ some preimages might be regular and some preimages might be ramification points. The cover $\mathcal{T} \rightarrow \mathcal{M}\mathcal{O}\mathcal{D}$ does not have any other ramification points.

A square-tiled surface $S = (X, q)$ in the moduli space of quadratic differentials defines a conical point X of the arithmetic Teichmüller disc if and only if (X, q) and $(X, -q)$ define the same point in the moduli space. In other words, a square-tiled surface S projects to a conical point of the arithmetic Teichmüller disc if turning it by $\pi/2$ we get an isomorphic square-tiled surface.

4.3. Encoding an arithmetic Teichmüller curve by a graph. Note that the set of the preimages in \mathcal{T} of the point B (with coordinate i) in $\mathcal{M}\mathcal{O}\mathcal{D}$ (see Figure 3) under the cover $\mathcal{T} \rightarrow \mathcal{M}\mathcal{O}\mathcal{D}$ coincides with the collection of the projections of the orbit $\text{PSL}(2, \mathbb{Z}) \cdot S_0$ in the moduli space \mathcal{Q}_g of quadratic differentials to the moduli space \mathcal{M}_g of curves. Since the cover $\mathcal{T} \rightarrow \mathcal{M}\mathcal{O}\mathcal{D}$ is, in general, ramified over i , the cardinality of the latter set might be less than the degree (4.4) of the cover. In this sense, the square-tiled surfaces are particularly *inconvenient* to enumerate the hyperbolic triangles as above.

Let us consider a flat torus T which does not correspond to any of the two conical points of the modular surface $\mathcal{M}\mathcal{O}\mathcal{D}$. For example, let T correspond to the point $4i$ of the fundamental domain. Let

$$g = \begin{pmatrix} 2 & 0 \\ 0 & 1/2 \end{pmatrix} \in \text{PSL}(2, \mathbb{R}).$$

We have that $T = g \cdot T_0$, where T_0 stands for the torus glued from the standard unit square. Let us then consider the following two closed paths γ_h, γ_r on the modular surface starting at $4i$, see Figure 3. The path γ_h follows the horizontal horocyclic loop, while the path γ_r descends along the vertical geodesic from $4i$ to i and returns back following the same vertical geodesic. The point T of $\mathcal{M}\mathcal{O}\mathcal{D}$ and the two loops γ_h, γ_r can be considered as a realization of the graph \mathbb{G}_T under the usual convention that the “folded” path γ_r is considered as the loop of the graph.

For any square-tiled surface S_0 consider the surface $S = g \cdot S_0$ in the $\text{PSL}(2, \mathbb{R})$ -orbit of S_0 . By construction, it projects to $T = g \cdot T_0$ under the cover $\mathcal{T} \rightarrow \mathcal{M}\mathcal{O}\mathcal{D}$. Let us consider all preimages of T under this cover, and consider the natural lifts of the loops γ_h and γ_r . Under the usual convention that “folded” paths are considered as loops of the graph, we get the graph \mathbb{G}_S from Section 4.1.

The geometry of the hyperbolic surface \mathcal{T} is completely encoded by each of the graphs $\mathbb{G} \simeq \mathbb{G}_S$ and $\check{\mathbb{G}}$. For example, the cusps of \mathcal{T} can be described as follows (see [HL1]).

Lemma 4.1. *The cusps of the hyperbolic surface \mathcal{T} are in the natural bijection with the orbits of the subgroup generated by the element*

$$h = \begin{pmatrix} 1 & 1 \\ 0 & 1 \end{pmatrix}$$

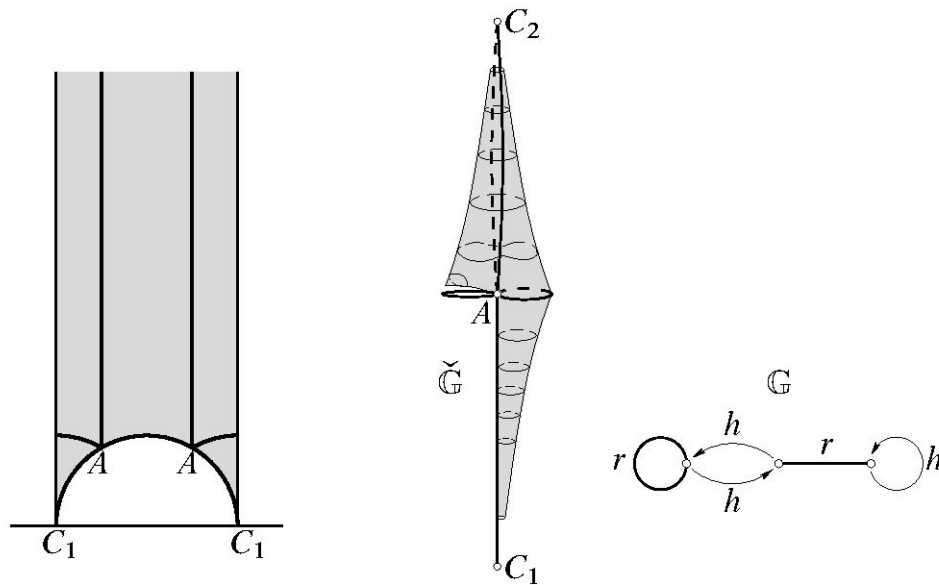

Figure 4. Partition of the Teichmüller curve $\widehat{\mathcal{T}}$, and associated graphs \mathbb{G} and $\check{\mathbb{G}}$.

on $\mathbb{G} \simeq \text{PSL}(2, \mathbb{Z})/\Gamma(S_0)$. In other words, the cusps of the hyperbolic surface \mathcal{T} are in the natural bijection with the maximal positively oriented chains of h -edges in the graph \mathbb{G} .

Remark 4.1. As it was pointed out by D. Zmiaikou, the lemma above should be applied in the context of the action of $\text{PSL}(2, \mathbb{R})$ and *not* of $\text{SL}(2, \mathbb{R})$, see [Zm].

It is clear from the construction that the graphs \mathbb{G}_S and $\check{\mathbb{G}}$ are in natural duality: under the natural embedding of \mathbb{G}_S into \mathcal{T} described above, the vertices of the graph \mathbb{G}_S are in the canonical one-to-one correspondence with the hyperbolic triangles in the partition of \mathcal{T} ; the edges of the graphs \mathbb{G}_S and $\check{\mathbb{G}}$ are also in the canonical one-to-one correspondence; under our usual convention concerning the loops, one can assume that the dual loops intersect transversally.

This allows us to encode the paths on \mathcal{T} , and, more particularly, the closed loops on \mathcal{T} with a fixed base point (or rather the homotopy classes of such loops in a homotopy fixing the base point), by the closed loops on the graph \mathbb{G} . This observation is used in the next section, where we discuss the monodromy representation of our main example, that is, the arithmetic Teichmüller curve $\widehat{\mathcal{T}}$ defined in Section 1.1.

Remark 4.2. One can go further, and encode the hyperbolic geodesics on any arithmetic Teichmüller disc using the continued fractions and the associated sequences in “letters” h, h^{-1}, r . This coding is the background of numerous computer experiments evaluating approximate values of Lyapunov exponents of the Hodge bundle over general arithmetic Teichmüller discs, as, for example, the ones described in [EKZ2] or in [DxL]. We refer the reader to the detailed surveys [Ser] and [Da] (and to references

cited there) for generalities on geometric coding of geodesics on the modular surface. The coding adapted particularly to Teichmüller discs is described in [MMöY].

5. Irreducibility of the Hodge bundle in the example

In this section we prove that the orthogonal splitting into the subbundles $\mathcal{E}(\zeta)$ and $\mathcal{E}(\zeta^2)$ is the unique irreducible decomposition of the Hodge bundle into $\mathrm{PSL}(2, \mathbb{R})$ -invariant (continuous) complex subbundles. We then determine the Zariski closure of the monodromy representations on the bundles $\mathcal{E}(\zeta)$ and $\mathcal{E}(\zeta^2)$ and generalize our irreducibility result to all finite covers of the Teichmüller curve $\widehat{\mathcal{T}}$ (strong irreducibility).

5.1. Irreducibility of the decomposition. We start with the following elementary lemma from linear algebra which we present without proof.

Lemma 5.1. *Let A, B be two $n \times n$ -matrices. If $\det(AB - BA) \neq 0$, then the corresponding linear automorphisms of \mathbb{R}^n (respectively \mathbb{C}^n) do not have any common one-dimensional invariant subspaces.*

It would be convenient to work with the dual *homology* vector bundle over the Teichmüller curve $\widehat{\mathcal{T}}$ and with its decomposition into direct sum of $\mathrm{PSL}(2, \mathbb{R})$ -invariant subbundles $\mathcal{E}_*(\zeta) \oplus \mathcal{E}_*(\zeta^2)$, where

$$\mathcal{E}_*(\zeta^k) := \mathrm{Ker}(T_* - \zeta^k \mathrm{Id}) \subseteq H_1(X; \mathbb{C}),$$

compare to (2.2). Of course, since $H^1(X; \mathbb{C})$ and $H_1(X; \mathbb{C})$ are in duality, we can safely replace $\mathcal{E}(\zeta^k)$ with $\mathcal{E}_*(\zeta^k)$ in our subsequent discussion of the complex Kontsevich–Zorich cocycle over $\widehat{\mathcal{T}}$.

Proposition 5.1. *The subbundles $\mathcal{E}(\zeta)$ and $\mathcal{E}(\zeta^2)$ over the Teichmüller curve $\widehat{\mathcal{T}}$ are irreducible, i.e., they do not have any nontrivial $\mathrm{PSL}(2, \mathbb{R})$ -invariant complex subbundles.*

Proof. We note that $\mathcal{E}_*(\zeta)$ and $\mathcal{E}_*(\zeta^2)$ are complex-conjugate and the monodromy respects the complex conjugation, hence it suffices to prove that one of them, for instance $\mathcal{E}_*(\zeta)$ is irreducible. We take the following two closed oriented paths ρ_1 and ρ_2 starting and ending at the same vertex \widehat{S}_1 , on the graph of Figure 5 (representing the $\mathrm{PSL}(2, \mathbb{Z})$ -orbit of \widehat{S}):

$$\begin{aligned} \rho_1 &:= h \cdot r h^{-3} r \cdot h \cdot r h^{-2} r, \\ \rho_2 &:= r h^{-1} r \cdot h^3 \cdot r h^{-1} r, \end{aligned}$$

where each path should be read from left to right. The paths are chosen to be compatible with the orientation of the graph. By the explicit calculation of the monodromy⁵ representation performed in Section B.3 of Appendix B (see also Section B.3 of Appendix B of [FMZ3] for details), one can compute the monodromy $X, Y : \mathcal{E}_*(\zeta) \rightarrow \mathcal{E}_*(\zeta)$ along the paths ρ_1, ρ_2 respectively, and verify that $\det(XY - YX) \neq 0$. Hence, the same property is valid for the monodromy along the two closed paths on the Teichmüller curve $\widehat{\mathcal{T}}$ whose free homotopy types are represented by the paths ρ_1, ρ_2 on the graph.

From Lemma 5.1 one concludes that $\mathcal{E}_*(\zeta)$ does not have any one-dimensional $\mathrm{PSL}(2, \mathbb{R})$ -invariant subbundles. Since the monodromy preserves the pseudo-Hermitian intersection form, which is non-degenerate, by duality the complex four-dimensional bundle $\mathcal{E}_*(\zeta)$ does not have any $\mathrm{PSL}(2, \mathbb{R})$ -invariant codimension one subbundles, i.e., three-dimensional ones.

Given the monodromy matrices X, Y along the paths ρ_1, ρ_2 one can compute (see again Section B.3 of Appendix B of this paper or of [FMZ3] for details) the induced monodromy matrices U, V in the second wedge product $\Lambda^2 \mathcal{E}_*(\zeta)$ of $\mathcal{E}_*(\zeta)$, and verify that $\det(UV - VU) \neq 0$. This proves that $\mathcal{E}_*(\zeta)$ does not have any two-dimensional $\mathrm{PSL}(2, \mathbb{R})$ -invariant subbundles. \square

Remark. The same kind of a straightforward proof of irreducibility based on Lemma 5.1 was implemented in a similar setting in Appendix B of [Z2].

Proposition 5.2. *The complex Hodge bundle $H_{\mathbb{C}}^1$ over the Teichmüller curve $\widehat{\mathcal{T}}$ has no nontrivial $\mathrm{PSL}(2, \mathbb{R})$ -invariant complex subbundles other than the subbundles $\mathcal{E}(\zeta)$ and $\mathcal{E}(\zeta^2)$.*

Proof. By Proposition 5.1 the bundles $\mathcal{E}(\zeta)$ and $\mathcal{E}(\zeta^2)$ do not have any non-trivial $\mathrm{PSL}(2, \mathbb{R})$ -invariant subbundles. Since the complex Hodge bundle $H_{\mathbb{C}}^1$ over $\widehat{\mathcal{T}}$ can be decomposed as an orthogonal direct sum

$$H_{\mathbb{C}}^1 = \mathcal{E}(\zeta) \oplus \mathcal{E}(\zeta^2),$$

this implies that $H_{\mathbb{C}}^1$ cannot have $\mathrm{PSL}(2, \mathbb{R})$ -invariant subbundles of dimension 1, 2, 3, otherwise the orthogonal projections to the direct summands would produce nontrivial $\mathrm{PSL}(2, \mathbb{R})$ -invariant subbundles. Moreover, since the flat connection preserves the nondegenerate pseudo-Hermitian intersection form, this implies that the orthogonal complement to a $\mathrm{PSL}(2, \mathbb{R})$ -invariant subbundle cannot have dimension 1, 2, 3, and thus the Hodge bundle does not have any $\mathrm{PSL}(2, \mathbb{R})$ -invariant subbundles of dimension 5, 6, 7.

If there existed a $\mathrm{PSL}(2, \mathbb{R})$ -invariant complex subbundle V of dimension 4 different from $\mathcal{E}(\zeta)$ and $\mathcal{E}(\zeta^2)$, its orthogonal projections π_1, π_2 to $\mathcal{E}(\zeta)$ and $\mathcal{E}(\zeta^2)$, respectively, would be $\mathrm{PSL}(2, \mathbb{R})$ -invariant isomorphisms. The composition $\pi_1^{-1} \circ \pi_2$

⁵Note that all monodromy matrices are defined up to a multiplication by the complex numbers ζ^k , $k = 0, 1, 2$, induced by the action of the automorphism group of a cyclic cover (1.2).

would establish a $\mathrm{PSL}(2, \mathbb{R})$ -invariant isomorphism between subbundles $\mathcal{E}(\zeta)$ and $\mathcal{E}(\zeta^2)$. This would imply that the vector bundles $\mathcal{E}(\zeta)$ and $\mathcal{E}(\zeta^2)$ would be isomorphic and would have isomorphic monodromy representations. However the bundles $\mathcal{E}(\zeta)$ and $\mathcal{E}(\zeta^2)$ are complex conjugate and the monodromy representation respects complex conjugation, hence the proof will be completed by finding a monodromy matrix C on $\mathcal{E}(\zeta)$ which has a different spectrum from its complex conjugate \bar{C} even up to multiplication times ζ^k for $k = 0, 1, 2$.

In fact, let us consider closed paths μ_1 and μ_2 starting and ending at the same vertex $\hat{S}_3 = \hat{S}$ on the graph of Figure 5 given by

$$\mu_1 := h \quad \text{and} \quad \mu_2 := (r^{-1}h^{-1}r) \cdot (r^{-1}h^{-1}r). \tag{5.1}$$

A closed path on the graph of the $\mathrm{PSL}(2, \mathbb{Z})$ -orbit of \hat{S} defines the free homotopy type of a path on the corresponding arithmetic Teichmüller curve $\hat{\mathcal{T}}$. An explicit computation (see Sections B.2 and B.3 of Appendix B of this paper or of the extended version [FMZ3] for details) shows that the monodromy matrices $A, B: \mathcal{E}_*(\zeta) \rightarrow \mathcal{E}_*(\zeta)$ associated to μ_1, μ_2 are

$$A := A_3^{\mathrm{hor}} = \begin{pmatrix} 0 & 0 & 1 & \zeta^2 \\ \zeta & 0 & 0 & \zeta \\ 0 & \zeta & 0 & \zeta \\ 0 & 0 & 0 & -\zeta^2 \end{pmatrix}, \tag{5.2}$$

$$B := A_1^{\mathrm{vert}} \cdot A_3^{\mathrm{vert}} = \begin{pmatrix} 0 & \zeta^2 - 1 & \zeta & 0 \\ 0 & \zeta & 0 & 0 \\ \zeta & \zeta - \zeta^2 & 1 - \zeta^2 & 0 \\ 1 - \zeta^2 & 1 - \zeta^2 & 1 - \zeta & 1 \end{pmatrix}. \tag{5.3}$$

We claim that the spectrum of the matrix $C = B \cdot A$ is different from that of its complex conjugate \bar{C} even up to the action of the automorphism group of the cyclic cover, that is, up to multiplication by the complex numbers $\zeta^k, k = 0, 1, 2$.

In fact, a computation shows that (see Appendix C of the extended version [FMZ3] of this paper)

$$C := B \cdot A = \begin{pmatrix} 1 - \zeta & \zeta^2 & 0 & -2\zeta \\ \zeta^2 & 0 & 0 & \zeta^2 \\ \zeta^2 - 1 & \zeta - 1 & \zeta & -2 \\ \zeta - 1 & \zeta - \zeta^2 & 1 - \zeta^2 & 2\zeta \end{pmatrix} \tag{5.4}$$

and that the characteristic polynomial of the matrix C is

$$T^4 + (\zeta^2 - \zeta)T^3 - 2\zeta^2T^2 + (\zeta^2 - 1)T + \zeta = (T - 1)(T^3 - 2\zeta T^2 + 2T - \zeta). \tag{5.5}$$

If the spectrum of C and \bar{C} up to multiplication times $\zeta^k, k = 0, 1, 2$, have a common element not equal to 1, then there exist $k \in \{0, 1, 2\}$ and $T \in \mathbb{C}$ such that

$$T^3 - 2\zeta T^2 + 2T - \zeta = (\zeta^k T)^3 - 2\bar{\zeta}(\zeta^k T)^2 + 2\zeta^k T - \bar{\zeta} = 0.$$

By subtracting the two identities above, taking into account that $\zeta^3 = 1$, we can derive the following identity:

$$2(\zeta^{2k-1} - \zeta)T^2 + 2(\zeta^k - 1)T + \zeta - 1/\zeta = 0.$$

The roots of the above second degree equation can be computed by hand for $k = 0, 1, 2$ and it can then be checked that none of them is a root of the characteristic polynomial in formula (5.5). The argument is therefore completed. \square

Corollary 5.1. *The real Hodge bundle $H_{\mathbb{R}}^1$ over the Teichmüller curve $\widehat{\mathcal{F}}$ has no non-trivial $\mathrm{PSL}(2, \mathbb{R})$ -invariant subbundles.*

Proof. Let V be a $\mathrm{PSL}(2, \mathbb{R})$ -invariant subbundle of the real Hodge bundle $H_{\mathbb{R}}^1$ over the Teichmüller curve $\widehat{\mathcal{F}}$. Its complexification $V_{\mathbb{C}}$ is a $\mathrm{PSL}(2, \mathbb{R})$ -invariant subbundle of the complex Hodge bundle. Moreover, by construction it is invariant under the complex conjugation. Since $\mathcal{E}(\zeta)$ and $\mathcal{E}(\zeta^2)$ are complex conjugate, Proposition 5.2 implies that V is trivial. \square

5.2. Zariski closure of the monodromy group. Following a suggestion of M. Möller we compute in this section the Zariski closure of the monodromy group of the bundle $\mathcal{E}(\zeta)$. This computation implies a stronger version of Proposition 5.1 stated in Proposition 5.3. The idea of this computation is due to A. Eskin.

Lemma 5.2. *The connected component of the identity of the Zariski closure of the monodromy group of the bundle $\mathcal{E}(\zeta)$ over the Teichmüller curve $\widehat{\mathcal{F}}$ is isomorphic to $\mathrm{SU}(3, 1)$.*

Proof. It follows from the theorem of C. McMullen cited in Section 2.1 that the monodromy group G of the flat bundle $\mathcal{E}(\zeta)$ preserves the pseudo-Hermitian form of signature $(3, 1)$. The direct computation of the generators of G shows that it is generated by matrices having determinant ζ^k , with k integer. Hence, the connected component of the Zariski closure of G containing the identity element is isomorphic to a subgroup of $\mathrm{SU}(3, 1)$. In order to prove that this subgroup is in fact the whole $\mathrm{SU}(3, 1)$, it is sufficient to show that the Lie algebra of the Zariski closure of G has the same dimension as the Lie algebra $\mathfrak{su}(3, 1)$, that is, 15. In other words, it is sufficient to find 15 linearly independent vectors in the Lie algebra of the Zariski closure of G , which we do, basically, by hands.

For any hyperbolic (or parabolic) element C in G the vector $X = \log(C)$ belongs to the Lie algebra \mathfrak{g}_0 of the Zariski closure of G . Also, together with any vector X , the Lie algebra \mathfrak{g}_0 contains the vector $\mathrm{Ad}_g(X) = gXg^{-1}$, where g is any element in G . Thus, it is sufficient to find a single vector in the Lie algebra \mathfrak{g}_0 , then conjugate it by elements of G ; as soon as we get by this procedure 15 linearly independent vectors, the proof is completed.

The rest of the computation is computer-assisted. We first find an explicit hyperbolic 4×4 matrix C in G and an algebraic expression for the matrix P which conjugates C to a diagonal matrix D . This allows us to compute $X = \log C = P \cdot \log D \cdot P^{-1}$ with arbitrary high precision.

As soon as we have a collection of linearly independent vectors in \mathfrak{g}_0 we construct a new vector as follows: we take some element g in G and compute the distance from gXg^{-1} to the subspace generated by our collection of independent vectors. If the distance is large enough, the new vector is linearly independent from the previous ones and we add it to our collection. If the distance is suspiciously small, we try another element g in G .

This algorithm is implemented in practice as follows. Let A and B be the matrices of formulas (5.2) and (5.3) respectively. Both elements are elliptic; A has order 18, B has order 6; the monodromy group G is generated by A and B . We check that the matrix $C := BA$ of formula (5.4) is hyperbolic, then we compute $X = \log C$ as indicated above, and show that the 15 vectors

$$\begin{aligned} A^n \cdot X \cdot A^{-n}, & \quad n = 0, \dots, 8; \\ B \cdot A^n \cdot X \cdot A^{-n} \cdot B^{-1}, & \quad n = 0, 2, 3, 4, 5, 6, \end{aligned}$$

are linearly independent (see Appendix C of [FMZ3] for details). \square

Remark 5.1. Our initial plan was to use parabolic elements in the group and not hyperbolic ones. Parabolic elements have an obvious advantage that their logarithms are polynomials and thus, the vector in the Lie algebra corresponding to an integer parabolic matrix can be computed explicitly. As a natural candidate for a parabolic element one can consider the map in cohomology of a square-tiled surface induced by a simultaneous twist of the horizontal cylinders by

$$h^n = \begin{pmatrix} 1 & n \\ 0 & 1 \end{pmatrix}$$

with n equal to, say, the least common multiple of the widths of the cylinders.

In the case of square-tiled surfaces corresponding to Abelian differentials we would certainly get parabolic elements in this way. However, in our case square-tiled surfaces correspond to quadratic differentials. A direct computation shows that the square-tiled surfaces $\widehat{S}_1, \widehat{S}_2, \widehat{S}_3$ in the $\mathrm{PSL}(2, \mathbb{Z})$ -orbit (see Figure 5) have the following property: the waist curve of any horizontal cylinder is homologous to zero. As a result, the monodromy along any path on the Teichmüller curve $\widehat{\mathcal{F}}$ represented by an element h^n as above is elliptic (i.e. has finite order) and not parabolic. We do not know whether the monodromy group in our example has at least one parabolic element.

5.3. Strong irreducibility of the decomposition

Proposition 5.3. *The subbundles $\mathcal{E}(\zeta)$ and $\mathcal{E}(\zeta^2)$ over the Teichmüller curve $\widehat{\mathcal{F}}$ are strongly irreducible, i.e., their lifts to any finite (possibly ramified) cover of $\widehat{\mathcal{F}}$ are irreducible.*

Proof. First note that $\mathcal{E}(\zeta)$ and $\mathcal{E}(\zeta^2)$ are complex-conjugate and the monodromy respects the complex conjugation. Moreover, for any finite, possibly ramified, cover the induced vector bundles stay complex conjugate. Thus, it suffices to show that one of them, say, $\mathcal{E}(\zeta)$ is strongly irreducible.

The second observation is that the component of identity of the Zariski closure of the monodromy group of a vector bundle is invariant under finite covers. In order to see this it is sufficient to note that for any hyperbolic or parabolic element g in the original monodromy group, the monodromy group of the vector bundle induced on a finite cover contains some power of g . Thus, Lemma 5.2 implies the statement of the proposition. \square

We would like to derive from the above Proposition 5.3 a generalization of Proposition 5.2 to arbitrary finite covers of the Teichmüller curve $\widehat{\mathcal{F}}$. The proof of that proposition can be in fact generalized after we have established the following algebraic lemma.

Lemma 5.3. *The matrix C in formula (5.4) has a simple eigenvalue $\mu \in \mathbb{C}$ of modulus one which is not a root of unity.*

Proof. Let $P_\zeta(T) = T^3 - 2\zeta T^2 + 2T - \zeta$ be the factor of the characteristic polynomial of the matrix C , written in formula (5.5). Since $\zeta^3 = 1$ the relation $\overline{P_\zeta(T)} = P_\zeta(1/\overline{T})$ holds, hence $P_\zeta(T)$ has exactly one root $\mu \in \mathbb{C}$ of modulus one (note that $P_\zeta(T)$ cannot have all the roots on the unit circle since the sum of all of its roots is equal to -2ζ which has modulus equal to 2). We will compute the minimal polynomial $M(T)$ (with integer coefficients) of μ and check that it is not a cyclotomic polynomial. The general procedure to compute the minimal polynomial of the roots of $P_\zeta(T)$ is to compute the resultant of $P_\zeta(T)$ and $\zeta^3 - 1$. In this particular case, it can be done by hand as follows. Assume $P_\zeta(T) = 0$, then $T(T^2 + 2) = \zeta(2 + T^2)$, hence

$$T^3(T^2 + 2)^3 = \zeta^3(2 + T^2)^3 = (2 + T^2)^3.$$

It follows then that $P_\zeta(T)$ is a divisor of the following polynomial with integer coefficients:

$$Q(T) := T^9 + 6T^7 - 8T^6 + 12T^5 - 12T^4 + 8T^3 - 6T^2 - 1.$$

The above polynomial factorizes as follows into irreducible factors:

$$Q(T) = (T - 1)(T^2 - T + 1)(T^6 + 2T^5 + 8T^4 + 5T^3 + 8T^2 + 2T + 1).$$

(The above factorization can be guessed by reduction modulo 2. In fact, $Q(T) \equiv_2 T^9 - 1$ and $T^9 - 1 \equiv_2 (T - 1)(T^2 - T + 1)(T^6 - T^3 + 1)$ and it is immediate to check that the factors $T - 1$, $T^2 - T + 1$ and $T^6 - T^3 + 1$ are irreducible modulo 2.) Since $P_\zeta(T)$ and $(T - 1)(T^2 - T + 1)$ have clearly no common roots, it follows that

$$M(T) = T^6 + 2T^5 + 8T^4 + 5T^3 + 8T^2 + 2T + 1.$$

The polynomial $M(T)$ is not cyclotomic. In fact, it is known (see [Mi]) that for all positive integers n with at most two distinct odd prime factors, the n -th cyclotomic polynomial has all the coefficients in $\{0, 1, -1\}$. It is also known that if n has r distinct odd prime factors then 2^r is a divisor of the degree of the n -th cyclotomic polynomial, which is equal to the value $\varphi(n)$ of the Euler's φ -function. It follows that all cyclotomic polynomials of degree 6 (which in fact appear only for $n = 7, 9, 14$ and 18) have all the coefficients in $\{0, 1, -1\}$. \square

Proposition 5.4. *The complex Hodge bundle $H_{\mathbb{C}}^1$ over any finite (possibly ramified) cover of the Teichmüller curve $\widehat{\mathcal{T}}$ has no nontrivial $\mathrm{PSL}(2, \mathbb{R})$ -invariant complex subbundles other than the lifts of the subbundles $\mathcal{E}(\zeta)$ and $\mathcal{E}(\zeta^2)$.*

Proof. By Proposition 5.3 the lifts of the bundles $\mathcal{E}(\zeta)$ and $\mathcal{E}(\zeta^2)$ to any finite (possibly ramified) cover of the Teichmüller curve $\widehat{\mathcal{T}}$ do not have any non-trivial $\mathrm{PSL}(2, \mathbb{R})$ -invariant subbundles. By the same argument as in the proof of Proposition 5.2, the proof can then be reduced to prove that there is no $\mathrm{PSL}(2, \mathbb{R})$ -invariant isomorphism between the lifts of the subbundles $\mathcal{E}(\zeta)$ and $\mathcal{E}(\zeta^2)$, which are complex conjugate subbundles of the Hodge bundle. By Lemma 5.3, the monodromy matrix $C = BA$ of formula (5.4) has a (simple) complex eigenvalue $\mu \in \mathbb{C}$ of modulus 1 which is not a root of unity. It follows that any power of C has a non-real eigenvalue of modulus 1, hence in particular the spectrum of any power of C is different from the spectrum of its complex conjugate. Thus for any (possibly ramified) finite cover of the Teichmüller curve $\widehat{\mathcal{T}}$, the monodromy representations on the lift of the bundles $\mathcal{E}(\zeta)$ and $\mathcal{E}(\zeta^2)$ are not isomorphic. In fact, for any finite cover of the $\widehat{\mathcal{T}}$, there exists a path with monodromy representation on the lifts of $\mathcal{E}(\zeta)$ and of $\mathcal{E}(\zeta^2)$ given by a power C^k of C and by its complex conjugate \bar{C}^k respectively, which have different spectrum and thus are not isomorphic. \square

By the same argument as in the proof of Corollary 5.1, this time based on Proposition 5.4 (instead of Proposition 5.2) we can prove that the real Hodge bundle is strongly irreducible.

Corollary 5.2. *The real Hodge bundle $H_{\mathbb{R}}^1$ over any finite (possibly ramified) cover of the Teichmüller curve $\widehat{\mathcal{T}}$ has no non-trivial $\mathrm{PSL}(2, \mathbb{R})$ -invariant subbundles.*

6. Non-varying phenomenon for certain loci of cyclic covers

It is known that the sum of the Lyapunov exponents of the Hodge bundle along the Teichmüller geodesic flow is the same for all $SL(2, \mathbb{R})$ -invariant suborbifold in any hyperelliptic locus in the moduli space of Abelian or quadratic differentials, see [EKZ2]. In the paper [ChMö] D. Chen and M. Möller proved the conjecture of M. Kontsevich and one of the authors on non-varying of the sum of the positive Lyapunov exponents for all Teichmüller curves in certain strata of low genera. We show that analogous non-varying phenomenon is valid for certain loci of cyclic covers.

Let M be a flat surface in some stratum of Abelian or quadratic differentials. Together with every closed regular geodesic γ on M we have a bunch of parallel closed regular geodesics filling a maximal cylinder cyl having a conical singularity at each of the two boundary components. By the *width* w of a cylinder we call the flat length of each of the two boundary components, and by the *height* h of a cylinder – the flat distance between the boundary components.

The number of maximal cylinders filled with regular closed geodesics of bounded length $w(\text{cyl}) \leq L$ is finite. Thus, for any $L > 0$ the following quantity is well defined:

$$N_{\text{area}}(M, L) := \frac{1}{\text{Area}(M)} \sum_{\substack{\text{cyl} \subset M \\ w(\text{cyl}) < L}} \text{Area}(\text{cyl}). \quad (6.1)$$

Note that in the above definition we do not assume that the area of the flat surface is equal to one. For a flat surface M denote by $M_{(1)}$ a proportionally rescaled flat surface of area one. The definition of $N_{\text{area}}(M, L)$ immediately implies that for any $L > 0$ one has

$$N_{\text{area}}(M_{(1)}, L) = N_{\text{area}}(M, \sqrt{\text{Area}(M)}L). \quad (6.2)$$

The following limit, when it exists,

$$c_{\text{area}}(M) := \lim_{L \rightarrow +\infty} \frac{N_{\text{area}}(M_{(1)}, L)}{\pi L^2} \quad (6.3)$$

is called the *Siegel–Veech constant*. By a theorem of H. Masur and A. Eskin [EMa], for any $PSL(2, \mathbb{R})$ -invariant suborbifold in any stratum of meromorphic quadratic differentials with at most simple poles, the limit does exist and is the same for almost all points of the suborbifold (which explains the term “constant”). Moreover, by Theorem 3 from [EKZ2], in genus zero the Siegel–Veech constant $c_{\text{area}}(M)$ depends only on the ambient stratum $\mathcal{Q}(d_1, \dots, d_m)$ and:

$$c_{\text{area}}(M) = -\frac{1}{8\pi^2} \sum_{j=1}^m \frac{d_j(d_j + 4)}{d_j + 2}. \quad (6.4)$$

Let $S = (\mathbb{CP}^1, q) \in \mathcal{Q}_1(n-5, -1^{n-1})$, where $n \geq 4$. Suppose that the limit (6.3) exists for S . Let $p: \widehat{C} \rightarrow \mathbb{CP}^1$ be a ramified cyclic cover

$$w^d = (z - z_1) \dots (z - z_n) \quad (6.5)$$

with ramification points exactly at the singularities of q . Suppose that d divides n , and that $d > 2$. Let us consider the induced flat surface $\widehat{S} := (\widehat{C}, p^*q)$. The lemma below mimics the analogous lemma in the original paper [EKZ2].

Lemma 6.1. *The Siegel–Veech constants of the two flat surfaces are related as follows:*

$$c_{\text{area}}(\widehat{S}) = \begin{cases} \frac{1}{d} \cdot c_{\text{area}}(S) & \text{when } d \text{ is odd,} \\ \frac{4}{d} \cdot c_{\text{area}}(S) & \text{when } d \text{ is even.} \end{cases} \quad (6.6)$$

Proof. Let us consider any maximal cylinder cyl on the underlying flat surface S . By maximality of the cylinder, each of the boundary components contains at least one singularity of q . Since S is a topological sphere, the two boundary components of cyl do not intersect. Since q has a single zero, this zero belongs to only one of the two components of cyl . Since the other component contain only poles, it contains exactly two poles.

Each of these two poles is a ramification point of p of degree d . Thus, any closed geodesic (waist curve) of the cylinder cyl lifts to a single closed geodesic of the length d when d is odd and to two distinct closed geodesics of the lengths $d/2$ when d is even.

Now note that, since $d > 2$ the quadratic differential p^*q is holomorphic. The condition that d divides n implies that p is non-ramified at infinity. At each of the ramification points z_1, \dots, z_n the quadratic differential q has a zero or pole, and it has no other singularities on \mathbb{CP}^1 . Hence, the (nontrivial) zeroes of p^*q are exactly the preimages of the points z_1, \dots, z_n , and, hence, any maximal cylinder on \widehat{S} projects to a maximal cylinder on S .

Note also that since S has area one, \widehat{S} has area d . We consider separately two different cases.

Case when d is odd. Applying (6.2) followed by the definition (6.1) and then followed by our remark on the relation between the corresponding maximal cylinders $\widehat{\text{cyl}}$ and cyl we get the following sequence of relations:

$$\begin{aligned} N_{\text{area}}(\widehat{S}_{(1)}, \sqrt{d} \cdot L) &= N_{\text{area}}(\widehat{S}, d \cdot L) \\ &= \sum_{\substack{\widehat{\text{cyl}} \subset \widehat{S} \\ w(\widehat{\text{cyl}}) < d \cdot L}} \frac{\text{Area}(\widehat{\text{cyl}})}{\text{Area}(\widehat{S})} = \sum_{\substack{\text{cyl} \subset S \\ w(\text{cyl}) < L}} \frac{\text{Area}(\text{cyl})}{\text{Area}(S)} \\ &= N_{\text{area}}(S, L). \end{aligned}$$

Hence,

$$\begin{aligned}
 c_{\text{area}}(\widehat{S}_{(1)}) &= \lim_{R \rightarrow +\infty} \frac{N_{\text{area}}(\widehat{S}_{(1)}, R)}{\pi R^2} \\
 &= \lim_{L \rightarrow +\infty} \frac{N_{\text{area}}(\widehat{S}_{(1)}, \sqrt{d}L)}{\pi \cdot d \cdot L^2} \\
 &= \frac{1}{d} \lim_{L \rightarrow +\infty} \frac{N_{\text{area}}(S, L)}{\pi L^2} \\
 &= \frac{1}{d} \cdot c_{\text{area}}(S),
 \end{aligned}$$

where we used the substitution $R := \sqrt{d}L$.

Case when d is even. These time our relations are slightly modified due to the fact that a preimage of a maximal cylinder downstairs having a waste curve of length ℓ is a disjoint union of two maximal cylinders with the waste curves of length $d \cdot \ell/2$.

$$\begin{aligned}
 N_{\text{area}}(\widehat{S}_{(1)}, \frac{\sqrt{d}}{2}L) &= N_{\text{area}}(\widehat{S}, \frac{d}{2}L) \\
 &= \sum_{\substack{\widehat{\text{cyl}} \subset \widehat{S} \\ w(\widehat{\text{cyl}}) < \frac{d}{2} \cdot L}} \frac{\text{Area}(\widehat{\text{cyl}})}{\text{Area}(\widehat{S})} = \sum_{\substack{\text{cyl} \subset S \\ w(\text{cyl}) < L}} \frac{\text{Area}(\text{cyl})}{\text{Area}(S)} \\
 &= N_{\text{area}}(S, L).
 \end{aligned}$$

Hence,

$$\begin{aligned}
 c_{\text{area}}(\widehat{S}_{(1)}) &= \lim_{R \rightarrow +\infty} \frac{N_{\text{area}}(\widehat{S}_{(1)}, R)}{\pi R^2} \\
 &= \lim_{L \rightarrow +\infty} \frac{N_{\text{area}}(\widehat{S}_{(1)}, \frac{\sqrt{d}}{2}L)}{\pi \cdot \frac{d}{4} \cdot L^2} \\
 &= \frac{4}{d} \lim_{L \rightarrow +\infty} \frac{N_{\text{area}}(S, L)}{\pi L^2} \\
 &= \frac{4}{d} \cdot c_{\text{area}}(S),
 \end{aligned}$$

where we used the substitution $R := \frac{\sqrt{d}}{2}L$. □

Proposition 6.1. *Under the assumptions of Lemma 6.1 one gets*

$$\frac{\pi^2}{3} \cdot c_{\text{area}}(\widehat{S}_{(1)}) = \frac{k}{12 \cdot d} \cdot \frac{(n-1)(n-2)}{n-3}, \text{ where } k = \begin{cases} 1 & \text{when } d \text{ is odd,} \\ 4 & \text{when } d \text{ is even.} \end{cases} \quad (6.7)$$

Proof. By applying the formula (6.4) for the Siegel–Veech constant of any $\mathrm{PSL}(2, \mathbb{R})$ -invariant suborbifold in a stratum $\mathcal{Q}_1(d_1, \dots, d_m)$ in genus zero to a particular case of the stratum $\mathcal{Q}_1(n - 5, -1^{n-1})$, we get

$$\frac{\pi^2}{3} \cdot c_{\text{area}}(S) = \frac{1}{24} \left(3(n - 1) - \frac{(n - 5)(n - 1)}{n - 3} \right) = \frac{1}{12} \frac{(n - 1)(n - 2)}{n - 3}.$$

By applying Lemma 6.1 we complete the proof. □

Let \mathcal{M}_1 be a $\mathrm{PSL}(2, \mathbb{R})$ -invariant suborbifold in the stratum $\mathcal{Q}_1(n - 5, -1^{n-1})$. It is immediate to check that the locus $\widehat{\mathcal{M}}_1$ of flat surfaces $\widehat{S}_{(1)}$ induced by cyclic covers (6.5), where d divides n , belongs to the stratum

$$\begin{aligned} &\mathcal{Q}_1(d(n - 3) - 2, (d - 2)^{n-1}) \quad \text{when } d \text{ is odd,} \\ &\mathcal{H}_1(d(n - 3)/2 - 1, (d/2 - 1)^{n-1}) \quad \text{when } d \text{ is even.} \end{aligned}$$

Applying Theorems 1 and 2 from [EKZ2] we get the following

Proposition 6.2. *The sum of the Lyapunov exponents of the Hodge bundle H^1 over \mathcal{M}_1 is equal to*

$$\lambda_1 + \dots + \lambda_g = \begin{cases} \frac{(d^2 - 1)(n - 2)}{12d} & \text{when } d \text{ is odd,} \\ \frac{(n - 2)(d^2(n - 3) + 2n)}{12d(n - 3)} & \text{when } d \text{ is even.} \end{cases} \tag{6.8}$$

Consider the particular case, when $d = 3$ and $n = 3m$. Then

$$\lambda_1 + \dots + \lambda_g = \frac{2n - 4}{9},$$

were, $g = n - 2$, by the Riemann–Hurwitz formula.

Note that $H^1 = \mathcal{E}(\zeta) \oplus \mathcal{E}(\zeta^2)$, where by [McM3] the restriction of the Hodge form to $\mathcal{E}(\zeta)$ has signature $(m - 1, 2m - 1)$ and the restriction of the Hodge form to $\mathcal{E}(\zeta^2)$ has signature $(2m - 1, m - 1)$. Thus, each of the subspaces has m zero exponents.

A. Lyapunov spectrum of pseudo-unitary cocycles: the proofs

In this appendix we prove Theorem 4. Its presentation below is inspired by discussions of the second author with A. Avila and J.-C. Yoccoz.

Recall that we consider an invertible transformation T or a flow T_t preserving a finite ergodic measure μ on a locally compact topological space M . Let U be a log-integrable cocycle over this transformation (flow) with values in the group $U(p, q)$ of pseudo-unitary matrices. The Oseledets Theorem (i.e. the multiplicative ergodic theorem) can be applied to complex cocycles. Denote by

$$\lambda_1 \geq \dots \geq \lambda_{p+q} \tag{A.1}$$

the Lyapunov spectrum of the pseudo-unitary cocycle U . Let

$$\lambda_{(1)} > \dots > \lambda_{(s)} \tag{A.2}$$

be all *distinct* Lyapunov exponents from the above spectrum. By applying the transformation (respectively, the flow) both in forward and backward directions, we get the corresponding Oseledets decomposition

$$E_{\lambda_{(1)}} \oplus \dots \oplus E_{\lambda_{(s)}} \tag{A.3}$$

at μ -almost every point of the base space M . By definition all nonzero vectors of each subspace $E_{\lambda_{(k)}}$ share the same Lyapunov exponent $\lambda_{(k)}$ which changes sign under the time reversing.

Lemma A.1. *For any nonzero $\lambda_{(k)}$, the subspace $E_{\lambda_{(k)}}$ of the Oseledets direct sum decomposition (A.3) is isotropic. Any two subspaces $E_{\lambda_{(i)}}$, $E_{\lambda_{(j)}}$ such that $\lambda_{(j)} \neq -\lambda_{(i)}$ are orthogonal with respect to the pseudo-Hermitian form.*

Proof. Consider a (measurable family of) norm(s) $\|\cdot\|$ for which the cocycle U is log-integrable. By Luzin’s theorem, the absolute value of the (measurable family of) pseudo-Hermitian product(s) $\langle \cdot, \cdot \rangle$ of any two vectors v_1, v_2 in \mathbb{C}^{p+q} is uniformly bounded on any compact set \mathcal{K} of positive measure in M by the product of their norms,

$$|\langle v_1, v_2 \rangle|_x \leq \text{const}(\mathcal{K}) \cdot \|v_1\|_x \cdot \|v_2\|_x \quad \text{for any } x \in \mathcal{K},$$

up to a multiplicative constant $\text{const}(\mathcal{K})$ depending only on the norm and on the compact set \mathcal{K} . By ergodicity of the transformation (flow), the trajectory of almost any point returns infinitely often to the compact set \mathcal{K} .

Suppose that there is a pair of Lyapunov exponents $\lambda_{(i)}$, $\lambda_{(j)}$ satisfying $\lambda_{(i)} \neq -\lambda_{(j)}$. We do not exclude the case when $i = j$. Consider a pair of vectors v_i, v_j such that $v_i \in E_{\lambda_{(i)}}$, $v_j \in E_{\lambda_{(j)}}$. By definition of $E_{\lambda_{(i)}}$, we have

$$\|T_t(v_1)\|_x \cdot \|T_t(v_2)\|_x \sim \exp((\lambda_{(i)} + \lambda_{(j)})t).$$

When $\lambda_{(i)} + \lambda_{(j)} < 0$ the latter expression tends to zero when $t \rightarrow +\infty$; when $\lambda_{(i)} + \lambda_{(j)} > 0$ the latter expression tends to zero when $t \rightarrow -\infty$. In both cases,

we conclude that for a subsequence of positive or negative times t_k (chosen when the trajectory visits the compact set \mathcal{K}) the pseudo-Hermitian product $\langle T_{t_k}(v_1), T_{t_k}(v_2) \rangle$ tends to zero. Since the pseudo-Hermitian product is preserved by the flow, this implies that it is equal to zero, so $\langle v_1, v_2 \rangle = 0$. Thus, we have proved that every subspace $E_{(\lambda_i)}$, except possibly $E_{(0)}$, is isotropic, and that any pair of subspaces $E_{\lambda_{(i)}}$, $E_{\lambda_{(j)}}$ such that $\lambda_{(j)} \neq -\lambda_{(i)}$ is orthogonal with respect to the pseudo-Hermitian form. \square

We proceed with the following elementary linear algebraic fact about isotropic subspaces of a pseudo-Hermitian form of signature (p, q) .

Lemma A.2. *The dimension $\dim_{\mathbb{C}} V$ of an isotropic subspace V of a pseudo-Hermitian form of signature (p, q) is bounded above by $\min(p, q)$.*

Proof. By choosing an appropriate basis, we can always suppose that $\langle \vec{a}, \vec{b} \rangle$ has the form

$$\langle \vec{a}, \vec{b} \rangle = a^1 \bar{b}^1 + \dots + a^p \bar{b}^p - a^{p+1} \bar{b}^{p+1} - \dots - a^{p+q} \bar{b}^{p+q}$$

where $\vec{a} = (a^1, \dots, a^{p+q})$, $\vec{b} = (b^1, \dots, b^{p+q})$ and $\vec{a}, \vec{b} \in \mathbb{C}^{p+q}$.

Without loss of generality we can assume that $p \leq q$. Let Σ be the null cone of the pseudo-Hermitian form, $\Sigma := \{\vec{a} \in \mathbb{C}^{p+q} \mid \langle \vec{a}, \vec{a} \rangle = 0\}$. We argue by contradiction. Suppose that $V \subset \Sigma$ is a vector subspace of dimension r with $r \geq p + 1$. By assumption, we can find $p + 1$ linearly independent vectors $\vec{v}_1, \dots, \vec{v}_{p+1} \in V$. By using the first p coordinates of these vectors, we obtain a collection of $p + 1$ vectors $\vec{w}_i = (v_i^1, \dots, v_i^p) \in \mathbb{C}^p$, $1 \leq i \leq p + 1$. Thus, one can find a non-trivial linear relation

$$t_1 \vec{w}_1 + \dots + t_{p+1} \vec{w}_{p+1} = \vec{0} \in \mathbb{C}^p.$$

Going back to the vectors \vec{v}_i , we conclude that the non-trivial linear combination

$$\vec{v} = t_1 \vec{v}_1 + \dots + t_{p+1} \vec{v}_{p+1} \in V - \{0\} \subset \Sigma - \{0\}$$

has the form $\vec{v} = (0, \dots, 0, v^{p+1}, \dots, v^{p+q})$, which leads to a contradiction since the inclusion $\vec{v} \in \Sigma$ forces $0 = |v^{p+1}|^2 + \dots + |v^{p+q}|^2$ (that is, $\vec{v} = 0$). \square

Lemma A.3. *The Lyapunov spectrum (A.1) is symmetric with respect to the sign change, that is for any k satisfying $1 \leq k \leq p + q$ one has*

$$\lambda_k = \lambda_{p+q+1-k}.$$

Proof. First note that together with any nonzero entry $\lambda_{(i)}$ the spectrum (A.2) necessarily contains the entry $-\lambda_{(i)}$. Otherwise, by Lemma A.1 the subspace $E_{\lambda_{(i)}}$ would be orthogonal to the entire vector space \mathbb{C}^{p+q} , which contradicts the assumption that the pseudo-Hermitian form is nondegenerate.

Consider a nonzero entry $\lambda_{(i)}$ in the spectrum (A.2). Let us decompose the direct sum (A.3) into two terms. As the first term we choose $E_{\lambda_{(i)}} \oplus E_{-\lambda_{(i)}}$, and we place all the other summands from (A.3) to the second term. By Lemma A.1 the two terms of the resulting direct sum are orthogonal. Hence, the restriction of the pseudo-Hermitian form to the first term is non-degenerate. By Lemma A.1 both subspaces $E_{\lambda_{(i)}}$ and $E_{-\lambda_{(i)}}$ are isotropic. It follows now from Lemma A.2 that their dimensions coincide. \square

Lemma A.4. *The dimension of the neutral subspace E_0 in the Oseledets decomposition (A.3) is at least $|p - q|$.*

Proof. Consider the direct sum E_u of all subspaces in the Oseledets decomposition (A.3) corresponding to strictly positive Lyapunov exponents $\lambda_{(i)} > 0$,

$$E_u := \bigoplus_{\lambda_{(i)} > 0} E_{\lambda_{(i)}}.$$

Similarly, consider the direct sum E_s of all subspaces in the Oseledets decomposition (A.3) corresponding to strictly negative Lyapunov exponents $\lambda_{(j)} < 0$,

$$E_s := \bigoplus_{\lambda_{(j)} < 0} E_{\lambda_{(j)}}.$$

By Lemma A.1 both subspaces E_u and E_s are isotropic. Hence, by Lemma A.2 the dimension of each of them is at most $\min(p, q)$. Since the dimension of the space $E_u \oplus E_0 \oplus E_s$ is $p + q$, it follows that the dimension of the neutral subspace E_0 (when it is present) is at least $|p - q|$. \square

By combining the statements of Lemma A.3 and of Lemma A.4, we get the statement of Theorem 4.

Concluding this appendix, we show the following simple criterion for the cocycle U to act by isometries on E_0 .

Lemma A.5. *Suppose that the neutral subspace (subbundle) E_0 has dimension exactly $|p - q|$. Then, the cocycle U acts on E_0 by isometries in the sense that the restriction of the pseudo-Hermitian form to the neutral subspace (subbundle) E_0 is either positive definite or negative definite.*

Proof. We claim that $E_0 \cap \Sigma = \{0\}$, where $\Sigma = \{v : \langle v, v \rangle = 0\}$ is the null-cone of the pseudo-Hermitian form $\langle \cdot, \cdot \rangle$ preserved by U . Indeed, since E_s and E_u have the same dimension (by Lemma A.3), and E_0 has dimension $|p - q|$ (by hypothesis), we have that $\dim_{\mathbb{C}} E_s = \dim_{\mathbb{C}} E_u = \min\{p, q\}$. So, if $E_0 \cap \Sigma \neq \{0\}$, the arguments of the proof of Lemma A.1 show that $E_s \oplus (E_0 \cap \Sigma)$ is an isotropic subspace whose dimension is at least $\min\{p, q\} + 1$, which contradicts Lemma A.2.

Since the pseudo-Hermitian form $\langle \cdot, \cdot \rangle$ is non-degenerate, the fact that $E_0 \cap \Sigma = \{0\}$ implies that the restriction of $\langle \cdot, \cdot \rangle$ to E_0 is (positive or negative) definite. In other words, the cocycle U restricted to E_0 preserves a family of definite forms $\langle \cdot, \cdot \rangle|_{E_0}$, i.e., U acts by isometries on E_0 . \square

B. Evaluation of the monodromy representation

We outline below the calculation of the monodromy representation. The reader will find a more detailed version in Appendix B of [FMZ3].

B.1. Scheme of the construction. Our plan is as follows. We start by constructing the square-tiled cyclic cover $\widehat{S} = \widehat{S}_3$ of the initial square-tiled surface S of Figure 1. Then we construct the $\text{PSL}(2, \mathbb{Z})$ -orbit of $\widehat{S} = \widehat{S}_3$. The results of this calculation are presented in Figure 5. In particular, the $\text{PSL}(2, \mathbb{Z})$ -orbit of the initial square-tiled surface $\widehat{S} = \widehat{S}_3$ has cardinality three, see Figure 5.

For each of the three square-tiled surfaces $\widehat{S}_1, \widehat{S}_2, \widehat{S}_3$ in the $\text{PSL}(2, \mathbb{Z})$ -orbit of \widehat{S}_3 we construct an appropriate generating set of integer cycles and a basis of the eigenspace $\mathcal{E}_{\widehat{S}_i}(\zeta) \subset H_1(\widehat{S}_i, \mathbb{C})$. Then we compute the six matrices of the action in homology induced by the basic horizontal shear h and by the counterclockwise rotation r by angle $\pi/2$ of these flat surfaces, where

$$h = \begin{pmatrix} 1 & 1 \\ 0 & 1 \end{pmatrix}, \quad r = \begin{pmatrix} 0 & -1 \\ 1 & 0 \end{pmatrix}, \tag{B.1}$$

thus obtaining an explicit description of the holonomy representation. Note that we work with the *homology*; the representation in the *cohomology* is dual.

Remark. Since we consider the representation of $\text{PSL}(2, \mathbb{Z})$ we might consider all matrices up to multiplication by -1 .

As a generating set of cycles of \widehat{S}_3 we take the cycles

$$a_1, b_1, c_1, d_1 = d_{1,1} + d_{1,2}, \dots, a_3, b_3, c_3, d_3 = d_{3,1} + d_{3,2} \tag{B.2}$$

represented in Figure 6, p. 532. Each of these cycles is represented by a close loop with a base point C . The action of the generator T of the group of deck transformations, defined in (1.3), transforms the generating cycles as follows:

$$\begin{aligned} T_* : a_i &\mapsto a_{i-1}, \\ T_* : b_i &\mapsto b_{i-1}, \\ T_* : c_i &\mapsto c_{i-1}, \\ T_* : d_i &\mapsto d_{i-1}. \end{aligned}$$

This implies that the following elements of $H_1(\widehat{S}_3, \mathbb{C})$,

$$\begin{aligned} a_+ &:= a_1 + \zeta a_2 + \zeta^2 a_3, \\ b_+ &:= b_1 + \zeta b_2 + \zeta^2 b_3, \\ c_+ &:= c_1 + \zeta c_2 + \zeta^2 c_3, \\ d_+ &:= d_1 + \zeta d_2 + \zeta^2 d_3, \end{aligned} \tag{B.3}$$

are eigenvectors of T_* corresponding to the eigenvalue $\zeta = \exp(2\pi i/3)$, and hence, they belong to the subspace $\mathcal{E}(\zeta)$. It can be verified that these elements are linearly independent, and, thus, form a basis of this four-dimensional subspace.

Let $h_3: \widehat{S}_3 \rightarrow \widehat{S}_3$ be the affine map induced by the horizontal shear $h \in \text{PSL}(2, \mathbb{R})$ of formula (B.1). (Let us recall that, by Convention 1 established in the beginning of Section 3.1, the notions “horizontal” and “vertical” correspond to the “landscape” orientation.)

By computing the matrix of h_3 with respect to the basis of formula (B.2) and by the definition of the basis a_+, b_+, c_+, d_+ , we see that the matrix A_3^{hor} of the induced map

$$h_3: \mathcal{E}_{\widehat{S}_3}(\zeta) \rightarrow \mathcal{E}_{\widehat{S}_3}(\zeta)$$

has the form

$$A_3^{\text{hor}} = \begin{pmatrix} 0 & 0 & 1 & \zeta^2 \\ \zeta & 0 & 0 & \zeta \\ 0 & \zeta & 0 & \zeta \\ 0 & 0 & 0 & -\zeta^2 \end{pmatrix}. \tag{B.4}$$

So far we have only used the horizontal cylinder decomposition for the initial square-tiled surface \widehat{S}_3 . We now construct a pattern of the same flat surface \widehat{S}_3 corresponding to the vertical cylinder decomposition. Finally, we rotate the resulting pattern by angle $\pi/2$ clockwise. We renumber the squares after the rotation. The resulting surface is the surface \widehat{S}_2 . It inherits a collection of generating cycles and the basis of the subspace $\mathcal{E}(\zeta)$ from the surface \widehat{S}_3 . By construction, the matrix R_3 of the map

$$r_3: \mathcal{E}_{\widehat{S}_3}(\zeta) \rightarrow \mathcal{E}_{\widehat{S}_2}(\zeta),$$

induced by the counterclockwise rotation $r \in \text{PSL}(2, \mathbb{R})$ by angle $\pi/2$, is the identity matrix, that is $r_3 = \text{Id}$, for our choice of the basis in $\mathcal{E}_{\widehat{S}_3}(\zeta)$ and in $\mathcal{E}_{\widehat{S}_2}(\zeta)$.

Note that, by construction, the points of the $\text{PSL}(2, \mathbb{Z})$ -orbit corresponding to the surfaces \widehat{S}_3 and \widehat{S}_2 satisfy $[\widehat{S}_2] = r^{-1}[\widehat{S}_3] = r[\widehat{S}_3]$.

Let us consider the affine map $\widehat{S}_2 \rightarrow \widehat{S}_1$ induced by the horizontal shear (in the landscape orientation) $h \in \text{PSL}(2, \mathbb{R})$ and let us define a generating set of cycles in the homology $H_1(\widehat{S}_1; \mathbb{Z})$ of \widehat{S}_1 and a basis of cycles in the subspace $\mathcal{E}_{\widehat{S}_1}(\zeta)$ as the images of generating cycles previously defined in $H_1(\widehat{S}_2; \mathbb{Z})$. By construction, the

matrix A_2^{hor} of the induced map

$$h_2: \mathcal{E}_{\widehat{S}_2}(\zeta) \rightarrow \mathcal{E}_{\widehat{S}_1}(\zeta)$$

is the identity matrix, $A_2^{\text{hor}} = \text{Id}$, for our choice of the bases in $\mathcal{E}_{\widehat{S}_2}(\zeta)$ and in $\mathcal{E}_{\widehat{S}_1}(\zeta)$.

Let us then consider the affine map $\widehat{S}_1 \rightarrow \widehat{S}_2$ induced by $h \in \text{PSL}(2, \mathbb{R})$. Now both homology spaces $H_1(\widehat{S}_1; \mathbb{Z})$ and $H_1(\widehat{S}_2; \mathbb{Z})$ are already endowed with the generating sets, so we can compute the matrix A_1^{hor} of the induced map

$$h_1: \mathcal{E}_{\widehat{S}_1}(\zeta) \rightarrow \mathcal{E}_{\widehat{S}_2}(\zeta).$$

For our choice of the basis in $\mathcal{E}_{\widehat{S}_1}(\zeta)$ and in $\mathcal{E}_{\widehat{S}_2}(\zeta)$ the matrix A_1^{hor} coincides with the matrix of the automorphism $\mathcal{E}_{\widehat{S}_2}(\zeta) \rightarrow \mathcal{E}_{\widehat{S}_2}(\zeta)$ induced by the affine map $\widehat{S}_2 \rightarrow \widehat{S}_2$ given by the horizontal shear $h^2 \in \text{PSL}(2, \mathbb{R})$.

By computing the matrix of the map $h_1 \circ h_2$ with respect to the basis (B.2) we derive the following expression for A_1^{hor} :

$$A_1^{\text{hor}} = \begin{pmatrix} 1 - \zeta & \zeta^2 - \zeta & \zeta^2 & 0 \\ 0 & \zeta^2 & 0 & 0 \\ \zeta^2 & \zeta - 1 & 0 & 0 \\ \zeta - 1 & \zeta - \zeta^2 & \zeta - \zeta^2 & 1 \end{pmatrix}.$$

Finally, we compute the action on the homology of \widehat{S}_1 induced by the automorphism of \widehat{S}_1 associated to the counterclockwise rotation $r \in \text{PSL}(2, \mathbb{R})$ by angle $\pi/2$. More specifically, we want to compute the matrix R_1 of the induced map

$$r_1: \mathcal{E}_{\widehat{S}_1}(\zeta) \rightarrow \mathcal{E}_{\widehat{S}_1}(\zeta).$$

with respect to the basis (B.3). Once again we compute the matrix of r_1 with respect to the basis (B.2), then derive the following expression for the matrix R_1 :

$$R_1 = \begin{pmatrix} \zeta & 0 & \zeta - \zeta^2 & 1 \\ 0 & 0 & 1 & \zeta^2 \\ 1 - \zeta^2 & 1 & 1 - \zeta & \zeta^2 \\ 1 - \zeta & \zeta^2 - \zeta & \zeta^2 - \zeta & -1 \end{pmatrix}.$$

B.2. Choice of concrete paths and calculation of the monodromy. Let us consider the maps on homology

$$\begin{aligned} v_1 &:= r_3^{-1} \cdot h_2^{-1} \cdot r_1: H_1(\widehat{S}_1; \mathbb{Z}) \rightarrow H_1(\widehat{S}_3; \mathbb{Z}), \\ v_2 &:= r_2^{-1} \cdot h_3^{-1} \cdot r_2: H_1(\widehat{S}_2; \mathbb{Z}) \rightarrow H_1(\widehat{S}_2; \mathbb{Z}), \\ v_3 &:= r_1^{-1} \cdot h_1^{-1} \cdot r_3: H_1(\widehat{S}_3; \mathbb{Z}) \rightarrow H_1(\widehat{S}_1; \mathbb{Z}) \end{aligned}$$

induced by the vertical shear $v = \begin{pmatrix} 1 & 0 \\ 1 & 1 \end{pmatrix}$. In the chosen bases of homology, the restrictions of these linear maps to the subspaces $\mathcal{E}_{\hat{S}_i}(\zeta)$ have respectively matrices

$$A_1^{\text{vert}} = R_3^{-1} \cdot (A_2^{\text{hor}})^{-1} \cdot R_1 = \text{Id} \cdot \text{Id} \cdot R_1 = R_1,$$

$$A_2^{\text{vert}} = R_2^{-1} \cdot (A_3^{\text{hor}})^{-1} \cdot R_2 = \text{Id} \cdot (A_3^{\text{hor}})^{-1} \cdot \text{Id} = (A_3^{\text{hor}})^{-1},$$

and

$$A_3^{\text{vert}} = R_1^{-1} \cdot (A_1^{\text{hor}})^{-1} \cdot R_3 = R_1^{-1} \cdot (A_1^{\text{hor}})^{-1} \cdot \text{Id} = R_1^{-1} \cdot (A_1^{\text{hor}})^{-1}.$$

By multiplying, we obtain

$$A_1^{\text{vert}} = \begin{pmatrix} \zeta & 0 & \zeta - \zeta^2 & 1 \\ 0 & 0 & 1 & \zeta^2 \\ 1 - \zeta^2 & 1 & 1 - \zeta & \zeta^2 \\ 1 - \zeta & \zeta^2 - \zeta & \zeta^2 - \zeta & -1 \end{pmatrix},$$

$$A_2^{\text{vert}} = \begin{pmatrix} 0 & \zeta^2 & 0 & \zeta \\ 0 & 0 & \zeta^2 & \zeta \\ 1 & 0 & 0 & 1 \\ 0 & 0 & 0 & -\zeta \end{pmatrix},$$

$$A_3^{\text{vert}} = \begin{pmatrix} 0 & 0 & 1 & \zeta^2 \\ \zeta & 0 & 0 & \zeta \\ 0 & \zeta & 0 & \zeta \\ 0 & 0 & 0 & -\zeta^2 \end{pmatrix}.$$

In the natural bases of homology, the restrictions of these linear maps to the subspaces $\Lambda^2 \mathcal{E}_{\hat{S}_i}(\zeta)$ have respectively matrices

$$W_1^{\text{hor}} = \begin{pmatrix} \zeta^2 - 1 & 0 & 0 & -\zeta & 0 & 0 \\ \zeta - \zeta^2 & -\zeta & 0 & \zeta^2 - 1 & 0 & 0 \\ 0 & \zeta - \zeta^2 & 1 - \zeta & 1 - \zeta^2 & \zeta^2 - \zeta & \zeta^2 \\ -\zeta & 0 & 0 & 0 & 0 & 0 \\ \zeta^2 - 1 & 0 & 0 & 1 - \zeta & \zeta^2 & 0 \\ \zeta - \zeta^2 & 1 - \zeta & \zeta^2 & 2\zeta^2 - \zeta - 1 & \zeta - 1 & 0 \end{pmatrix},$$

$$W_3^{\text{hor}} = \begin{pmatrix} 0 & -\zeta & -1 & 0 & 0 & \zeta \\ 0 & 0 & 0 & -\zeta & -1 & \zeta \\ 0 & 0 & 0 & 0 & 0 & -\zeta^2 \\ \zeta^2 & 0 & \zeta^2 & 0 & -\zeta^2 & 0 \\ 0 & 0 & -1 & 0 & 0 & 0 \\ 0 & 0 & 0 & 0 & -1 & 0 \end{pmatrix},$$

$$W_1^{\text{vert}} = \begin{pmatrix} 0 & \zeta & 1 & 0 & 0 & -\zeta \\ \zeta & 1-\zeta & \zeta^2 & \zeta^2-\zeta & -1 & 0 \\ 1-\zeta^2 & \zeta^2-\zeta & -1 & \zeta^2+\zeta-2 & \zeta-\zeta^2 & 0 \\ 0 & \zeta^2-1 & \zeta-\zeta^2 & -1 & -\zeta^2 & 1 \\ 0 & \zeta-1 & 1-\zeta^2 & \zeta-\zeta^2 & 1-\zeta & -\zeta \\ \zeta^2-\zeta & 0 & 0 & 1-\zeta^2 & -\zeta & 0 \end{pmatrix},$$

$$W_2^{\text{vert}} = \begin{pmatrix} 0 & 0 & 0 & \zeta & 1 & -1 \\ -\zeta^2 & 0 & -\zeta & 0 & \zeta^2 & 0 \\ 0 & 0 & 0 & 0 & -1 & 0 \\ 0 & -\zeta^2 & -\zeta & 0 & 0 & \zeta^2 \\ 0 & 0 & 0 & 0 & 0 & -1 \\ 0 & 0 & -\zeta & 0 & 0 & 0 \end{pmatrix},$$

$$W_3^{\text{vert}} = \begin{pmatrix} 0 & -\zeta & -1 & 0 & 0 & \zeta \\ 0 & 0 & 0 & -\zeta & -1 & \zeta \\ 0 & 0 & 0 & 0 & 0 & -\zeta^2 \\ \zeta^2 & 0 & \zeta^2 & 0 & -\zeta^2 & 0 \\ 0 & 0 & -1 & 0 & 0 & 0 \\ 0 & 0 & 0 & 0 & -1 & 0 \end{pmatrix},$$

and $W_1^{\text{hor}} = \text{Id}$.

Let us consider now the following loop ρ_1 on $\widehat{\mathcal{F}}$: start with a horizontal move from \widehat{S}_1 and follow the trajectory:

$$1 \xrightarrow{\text{hor}} 2 \xrightarrow{\text{vert}} 2 \xrightarrow{\text{vert}} 2 \xrightarrow{\text{vert}} 2 \xrightarrow{\text{hor}} 1 \xrightarrow{\text{vert}} 3 \xrightarrow{\text{vert}} 1. \tag{B.5}$$

The corresponding monodromy matrices X in $\mathcal{E}(\zeta)$ and U in $\Lambda^2\mathcal{E}(\zeta)$ are given respectively by the formulas

$$X := A_3^{\text{vert}} \cdot A_1^{\text{vert}} \cdot A_2^{\text{hor}} \cdot (A_2^{\text{vert}})^3 \cdot A_1^{\text{hor}},$$

and

$$U := W_3^{\text{vert}} \cdot W_1^{\text{vert}} \cdot W_2^{\text{hor}} \cdot (W_2^{\text{vert}})^3 \cdot W_1^{\text{hor}}.$$

Let us consider now the second loop ρ_2 on $\widehat{\mathcal{F}}$: start with a vertical move from \widehat{S}_1

and follow the trajectory:

$$1 \xrightarrow{\text{vert}} 3 \xrightarrow{\text{hor}} 3 \xrightarrow{\text{hor}} 3 \xrightarrow{\text{hor}} 3 \xrightarrow{\text{vert}} 1 \quad (\text{B.6})$$

The corresponding monodromy matrices Y in $\mathcal{E}(\zeta)$ and V in $\Lambda^2 \mathcal{E}(\zeta)$ are given respectively by the formulas

$$Y := A_3^{\text{vert}} \cdot (A_3^{\text{hor}})^3 \cdot A_1^{\text{vert}}$$

and

$$V := W_3^{\text{vert}} \cdot (W_3^{\text{hor}})^3 \cdot W_1^{\text{vert}}$$

By explicitly computing X , Y and U , V and by computing determinants we get the following numerical result:

$$\det(XY - YX) = -285$$

and

$$\det(UV - VU) = -5292.$$

Acknowledgments. The authors are grateful to A. Eskin, M. Kontsevich, M. Möller, and J.-C. Yoccoz for extremely stimulating discussions, and to Y. Guivarch for the question behind Proposition 3.2 above.

We highly appreciated explanations of M. Kontsevich and A. Wright concerning the Deligne Semisimplicity Theorem.

We would like to thank M. Möller for suggesting to us that the statement of Lemma 5.2 should hold, A. Eskin for his ideas leading to the proof of this lemma, and G. Pearlstein, I. Rivin and M. Sapir for interesting discussions around the computation of the Zariski closure of concrete examples.

The authors are thankful to Collège de France, HIM, IHES, IUF, IMPA, MPIM, and the Universities of Chicago, Maryland, Rennes 1, and Paris 7 for hospitality during the preparation of this paper.

G.F. was supported by the National Science Foundation grants DMS 0800673 and DMS 1201534. C.M. was partially supported by the Balzan Research Project of J. Palis, and C.M. and A.Z. were partially supported by the French ANR grant “GeoDyM” (ANR-11-BS01-0004).

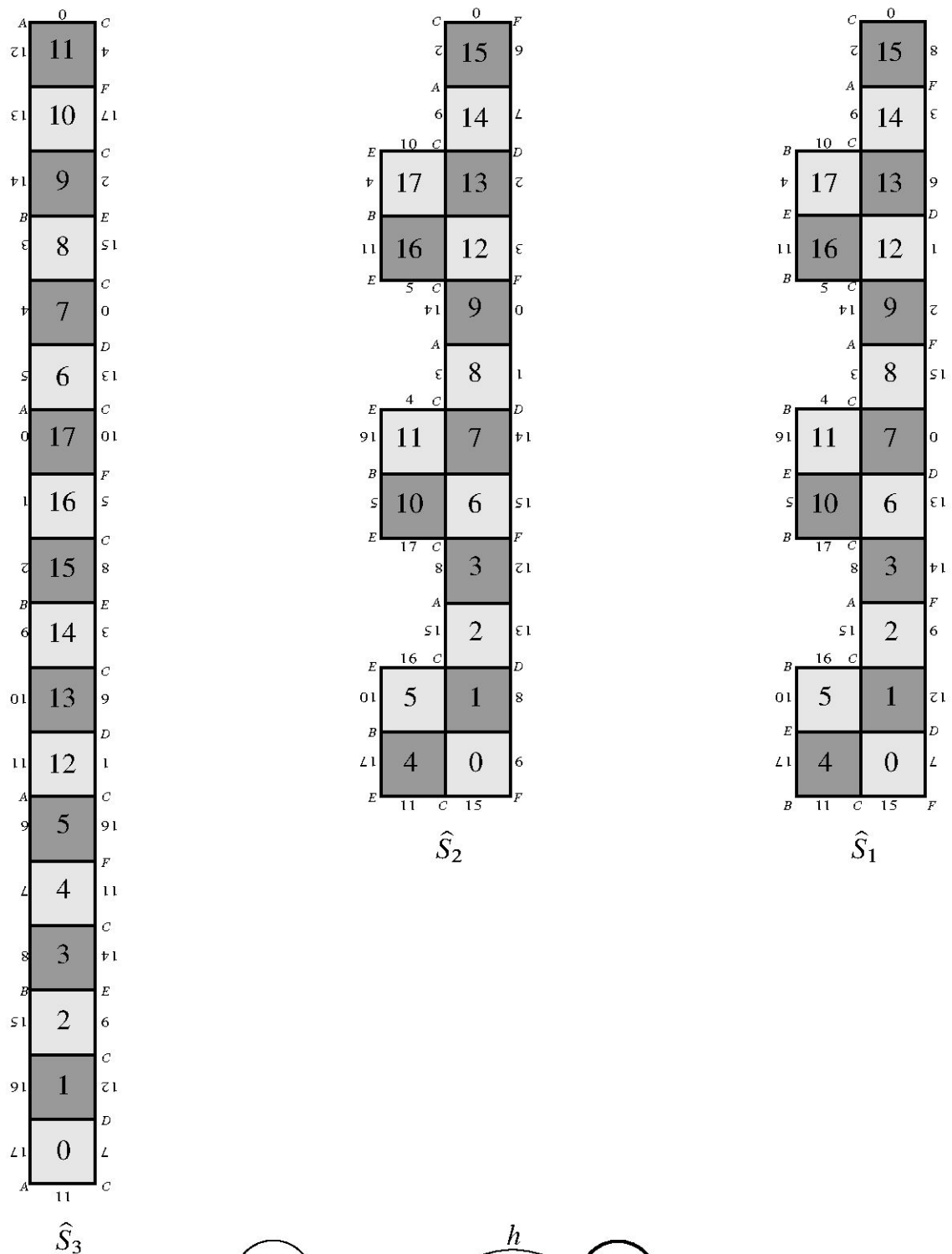

Figure 5. $PSL(2, \mathbb{Z})$ -orbit of $\hat{S} = \hat{S}_3$.

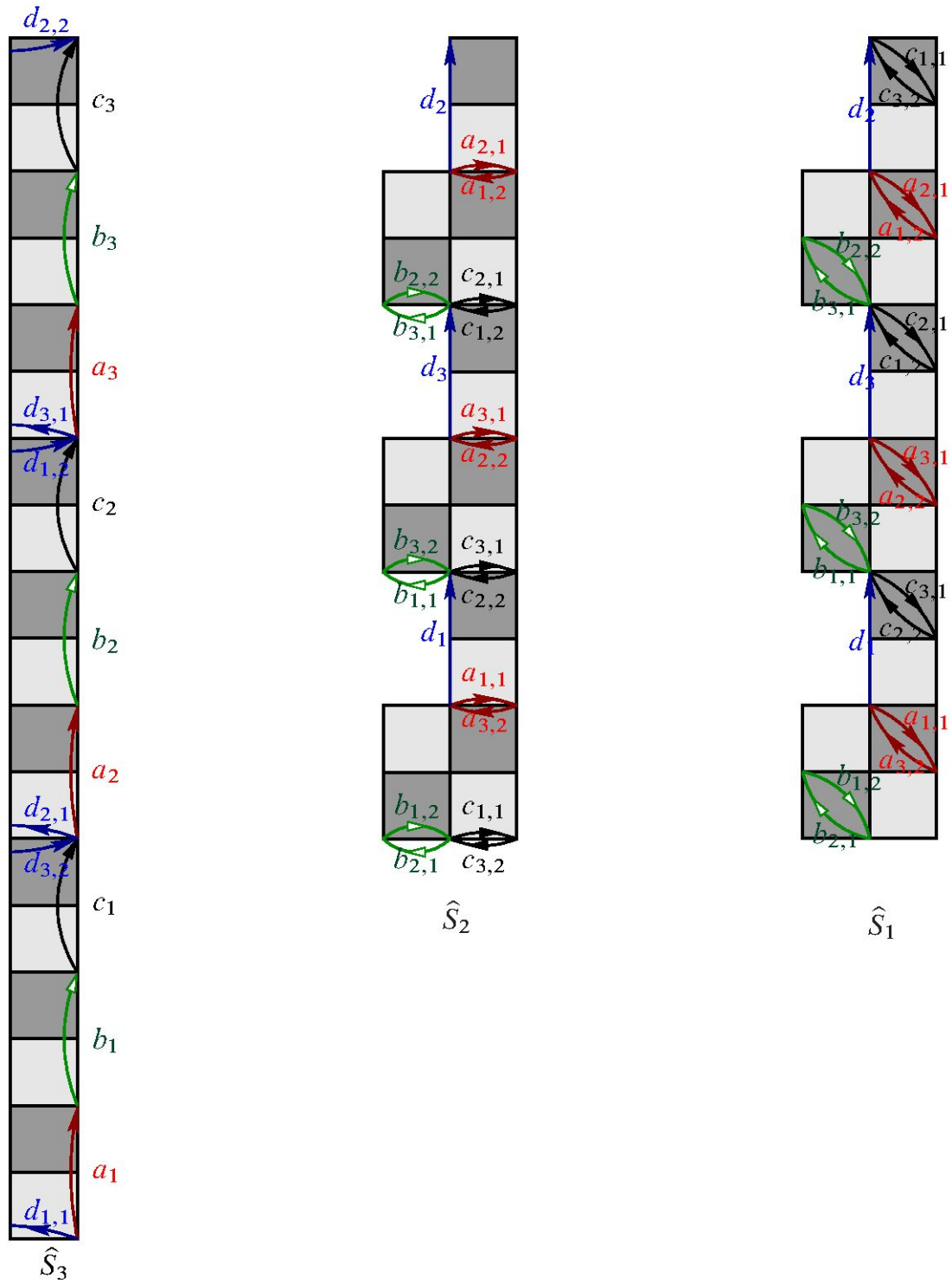

Figure 6. Construction of bases of cycles for the surfaces \hat{S}_i .

References

- [AEMö] A. Avila, A. Eskin and M. Möller, Symplectic and isometric $SL(2, \mathbb{R})$ invariant sub-bundles of the Hodge bundle. Preprint, [arXiv:1209.2854](https://arxiv.org/abs/1209.2854).
- [AV] A. Avila and M. Viana, Simplicity of Lyapunov spectra: Proof of the Kontsevich–Zorich conjecture. *Acta Math.* **198** (2007), 1–56. [Zbl 1143.37001](https://zbmath.org/journal/Acta-Math/) [MR 2316268](https://www.ams.org/mathscinet/item.aspx?si=MR&id=MR2316268)
- [AMY] A. Avila, C. Matheus, and J.-C. Yoccoz, On the Kontsevich–Zorich cocycle over McMullen’s family of symmetric translation surfaces. In preparation.
- [B1] I. Bouw, Tame covers of curves: p -ranks and fundamental groups. PhD thesis, University of Utrecht, 1998.
- [B2] I. Bouw, The p -rank of ramified covers of curves. *Compositio Math.* **126** (2001), 295–322. [Zbl 1056.14036](https://zbmath.org/journal/Compositio-Math/) [MR 1834740](https://www.ams.org/mathscinet/item.aspx?si=MR&id=MR1834740)
- [BMö] I. Bouw and M. Möller, Teichmüller curves, triangle groups and Lyapunov exponents. *Ann. of Math.* **172** (2010), 139–185. [Zbl 1203.37049](https://zbmath.org/journal/Ann-of-Math/) [MR 2680418](https://www.ams.org/mathscinet/item.aspx?si=MR&id=MR2680418)
- [ChMö] D. Chen and M. Möller, Non-varying sums of Lyapunov exponents of Abelian differentials in low genus. *Geom. Topol.* **16** (2012), no. 4, 2427–2479. [Zbl 1266.14018](https://zbmath.org/journal/Geom-Topol/) [MR 3033521](https://www.ams.org/mathscinet/item.aspx?si=MR&id=MR3033521)
- [Da] F. Dalbo, *Geodesic and horocyclic trajectories*. Translated from the 2007 French original, Universitext, Springer, London; EDP Sciences, Les Ulis 2011. [Zbl 1205.37050](https://zbmath.org/journal/Universitext/) [MR 2766419](https://www.ams.org/mathscinet/item.aspx?si=MR&id=MR2766419)
- [DxL] V. Delecroix and S. Lelièvre, in progress.
- [DI] P. Deligne, Un théorème de finitude pour la monodromie. In *Discrete groups in geometry and analysis*, Progr. Math. 67, Birkhäuser, Boston, Mass., 1987, 1–19. [Zbl 0656.14010](https://zbmath.org/journal/Discrete-groups-in-geometry-and-analysis/) [MR 0900821](https://www.ams.org/mathscinet/item.aspx?si=MR&id=MR0900821)
- [EI] A. Elkin, The rank of the Cartier operator on cyclic covers of the projective line. *J. Algebra* **327** (2011), 1–12. [Zbl 1216.14026](https://zbmath.org/journal/J-Algebra/) [MR 2746026](https://www.ams.org/mathscinet/item.aspx?si=MR&id=MR2746026)
- [EKZ1] A. Eskin, M. Kontsevich, and A. Zorich, Lyapunov spectrum of square-tiled cyclic covers. *J. Mod. Dyn.* **5** (2011), no. 2, 319–353. [Zbl 1254.32019](https://zbmath.org/journal/J-Mod-Dyn/) [MR 2820564](https://www.ams.org/mathscinet/item.aspx?si=MR&id=MR2820564)
- [EKZ2] A. Eskin, M. Kontsevich, and A. Zorich, Sum of Lyapunov exponents of the Hodge bundle with respect to the Teichmüller geodesic flow. *Publ. Math. Inst. Hautes Études Sci.* **120** (2014), no. 1, [Doi 10.1007/s10240-013-0060-3](https://doi.org/10.1007/s10240-013-0060-3).
- [EMkMr] A. Eskin, J. Marklof, and D. Morris, Unipotent flows on the space of branched covers of Veech surfaces, *Ergodic Theory Dynam. Systems* **26** (2006), 129–162. [Zbl 1085.37021](https://zbmath.org/journal/Ergodic-Theory-Dynam-Systems/) [MR 2201941](https://www.ams.org/mathscinet/item.aspx?si=MR&id=MR2201941)
- [EMa] A. Eskin and H. Masur, Asymptotic formulas on flat surfaces. *Ergodic Theory Dynam. Systems* **21** (2001), 443–478. [Zbl 1096.37501](https://zbmath.org/journal/Ergodic-Theory-Dynam-Systems/) [MR 1827113](https://www.ams.org/mathscinet/item.aspx?si=MR&id=MR1827113)
- [EMir] A. Eskin and M. Mirzakhani, Invariant and stationary measures for the $SL(2, \mathbb{R})$ action on moduli space. Preprint, [arXiv:1302.3320](https://arxiv.org/abs/1302.3320).
- [Fil1] S. Filip, Splitting mixed Hodge structures over affine invariant manifolds. Preprint, [arXiv:1311.2350](https://arxiv.org/abs/1311.2350).
- [Fil2] S. Filip, Semisimplicity and rigidity of the Kontsevich–Zorich cocycle. Preprint, [arXiv:1307.7314](https://arxiv.org/abs/1307.7314).

- [F1] G. Forni, Deviation of ergodic averages for area-preserving flows on surfaces of higher genus. *Ann. of Math.* **155** (2002), 1–103. [Zbl 1034.37003](#) [MR 1888794](#)
- [F2] G. Forni, On the Lyapunov exponents of the Kontsevich–Zorich cocycle. In *Handbook of dynamical systems* (ed. by B. Hasselblatt and A. Katok), Vol. 1B, Elsevier, Amsterdam 2006, 549–580. [Zbl 1130.37302](#) [MR 2186248](#)
- [FM] G. Forni and C. Matheus, An example of a Teichmüller disk in genus 4 with degenerate Kontsevich–Zorich spectrum. Preprint, [arXiv:0810.0023v1](#).
- [FMZ1] G. Forni, C. Matheus, and A. Zorich, Square-tiled cyclic covers. *J. Mod. Dyn.* **5** (2011), no. 2, 285–318. [Zbl 1276.37021](#) [MR 2820563](#)
- [FMZ2] G. Forni, C. Matheus, and A. Zorich, Lyapunov spectrum of invariant subbundles of the Hodge bundle. *Ergodic Theory Dynam. Systems* **34** (2014), no. 2, 353–408. [Zbl 06296541](#)
- [FMZ3] G. Forni, C. Matheus, and A. Zorich, Zero Lyapunov exponents of the Hodge bundle. Preprint, [arXiv:1201.6075](#).
- [GHS] E. Gutkin, P. Hubert, and T. Schmidt, Affine diffeomorphisms of translation surfaces: periodic points, Fuchsian groups, and arithmeticity. *Ann. Sci. École Norm. Sup. (4)* **36** (2003), no. 6, 847–866. [Zbl 1106.37018](#) [MR 2032528](#)
- [Hr] F. Herrlich, Teichmüller curves defined by characteristic origamis. In *The geometry of Riemann surfaces and Abelian varieties*, Contemp. Math. 397, Amer. Math. Soc., Providence, RI, 2006, 133–144. [Zbl 1098.14019](#) [MR 2218004](#)
- [HL1] P. Hubert and S. Lelièvre, Prime arithmetic Teichmüller discs in $\mathcal{H}(2)$. *Israel J. Math.* **151** (2006) 281–321. [Zbl 1138.37016](#) [MR 2214127](#)
- [HL2] P. Hubert and S. Lelièvre, Noncongruence subgroups in $\mathcal{H}(2)$. *Internat. Math. Res. Notices* **1** (2005), 47–64. [Zbl 1069.30074](#) [MR 2130053](#)
- [HS] P. Hubert and T. Schmidt, An introduction to Veech surfaces. In *Handbook of dynamical systems* (ed. by B. Hasselblatt and A. Katok), Vol. 1B, Elsevier, Amsterdam 2006, 501–526. [Zbl 1130.37367](#) [MR 2186246](#)
- [Koo] J. K. Koo, On holomorphic differentials of some algebraic function field of one variable over \mathbb{C} . *Bull. Austral. Math. Soc.* **43** (1991), 399–405. [Zbl 0724.30033](#) [MR 1107394](#)
- [Ma] H. Masur, Interval exchange transformations and measured foliations. *Ann. of Math.* **115** (1982), 169–200. [Zbl 0497.28012](#) [MR 0644018](#)
- [MMöY] C. Matheus, M. Möller, and J.-C. Yoccoz, A criterion for the simplicity of the Lyapunov spectrum of square-tiled surfaces. Preprint, [arXiv:1305.2033](#).
- [MY] C. Matheus and J.-C. Yoccoz, The action of the affine diffeomorphisms on the relative homology group of certain exceptionally symmetric origamis. *J. Mod. Dyn.* **4** (2010), 453–486. [Zbl 1220.37004](#) [MR 2729331](#)
- [McM1] C. McMullen, Dynamics of $SL(2, \mathbb{R})$ over moduli space in genus two. *Ann. of Math.* **165** (2007), 397–456. [Zbl 1131.14027](#) [MR 2299738](#)
- [McM2] C. McMullen, Teichmüller curves in genus two: discriminant and spin. *Math. Ann.* **333** (2005), no. 1, 87–130. [Zbl 1086.14024](#) [MR 2169830](#)
- [McM3] C. McMullen, Braid groups and Hodge theory. *Math. Ann.* **355** (2012), 893–946. [Zbl 06149478](#) [MR 3020148](#)

- [Mi] A. Migotti, Zur Theorie der Kreisteilungsgleichung. *Z. B. der Math.-Naturwiss. Classe der Kaiserlichen Akademie der Wissenschaften Wien* **87** (1883), 7–14. [JFM 14.0127.01](#)
- [Mö] M. Möller, Variations of Hodge structures of a Teichmüller curve. *J. Amer. Math. Soc.* **19** (2006), 327–344. [Zbl 1090.32004](#) [MR 2188128](#)
- [Schm1] G. Schmithüsen, An algorithm for finding the Veech group of an origami. *Experimental. Math.* **13** (2004), 459–472. [Zbl 1078.14036](#) [MR 2118271](#)
- [Schm2] G. Schmithüsen, Examples for Veech groups of origamis. In *The geometry of Riemann surfaces and abelian varieties*, Contemp. Math. 397, Amer. Math. Soc., Providence, RI, 2006, 193–206. [Zbl 1099.14015](#) [MR 2218009](#)
- [Ser] C. Series, Geometrical methods of symbolic coding. In *Ergodic theory, symbolic dynamics and hyperbolic spaces* (ed. by T. Bedford, M. Keane, C. Series), Oxford Sci. Publ., Oxford University Press, New York 1991, 125–151. [Zbl 0752.30026](#) [MR 1130175](#)
- [Tr] R. Treviño, On the non-uniform hyperbolicity of the Kontsevich–Zorich cocycle for quadratic differentials. *Geom. Dedicata* **163** (2013), 311–338. [Zbl 1271.32016](#) [3032697](#) [MR 3032697](#)
- [V] W. Veech, Gauss measures for transformations on the space of interval exchange maps. *Ann. of Math.* **115** (1982), 201–242. [Zbl 0486.28014](#) [MR 0644019](#)
- [W] A. Wright, Schwarz triangle mappings and Teichmüller curves I: abelian square-tiled surfaces. *J. Mod. Dyn.* **6** (2012), no. 3, 405–426. [Zbl 1254.32021](#) [MR 2988814](#)
- [Y] J.-C. Yoccoz, *Surfaces à petits carreaux*. Notes of the courses 2010/2011 and 2011/2012 given at Collège de France, Paris.
- [Zm] D. Zmiaikou, Origamis et groupes de permutations. Ph. D. Thesis, Orsay, 2011.
- [Z1] A. Zorich, Square tiled surfaces and Teichmüller volumes of the moduli spaces of Abelian differentials. In *Rigidity in dynamics and geometry* (ed. by M. Burger and A. Iozzi), contributions from the programme ergodic theory, geometric rigidity and number theory, Isaac Newton Institute for the Mathematical Sciences, Cambridge, UK, January 5–July 7, 2000. Springer, Berlin 2002, 459–471. [Zbl 1038.37015](#) [MR 1919417](#)
- [Z2] A. Zorich, How do the leaves of a closed 1-form wind around a surface? In *Pseudoperiodic topology*, Amer. Math. Soc. Transl. Ser. (2) 197, Amer. Math. Soc., Providence, RI, 1999, 135–178. [Zbl 0976.37012](#) [MR 1733872](#)

Received March 17, 2012

Giovanni Forni, Department of Mathematics, University of Maryland, College Park, MD 20742-4015, U.S.A.

E-mail: gforni@math.umd.edu

Carlos Matheus, CNRS, LAGA, Institut Galilée, Université Paris 13, 99, Avenue Jean-Baptiste Clément, 93430, Villetaneuse, France

E-mail: matheus@impa.br

Anton Zorich, Institut de mathématiques de Jussieu and Institut universitaire de France, Université Paris 7, Paris, France

E-mail: anton.zorich@gmail.com