

# Epiphytic bryophyte communities of *Olea europaea* in Portugal : a background survey for future evaluation of environmental quality

Autor(en): **Sim-Sim, Manuela / Rego, Francisco / de Sousa, Jorge**

Objektyp: **Article**

Zeitschrift: **Cryptogamica Helvetica**

Band (Jahr): **18 (1995)**

PDF erstellt am: **20.07.2024**

Persistenter Link: <https://doi.org/10.5169/seals-821129>

## **Nutzungsbedingungen**

Die ETH-Bibliothek ist Anbieterin der digitalisierten Zeitschriften. Sie besitzt keine Urheberrechte an den Inhalten der Zeitschriften. Die Rechte liegen in der Regel bei den Herausgebern.

Die auf der Plattform e-periodica veröffentlichten Dokumente stehen für nicht-kommerzielle Zwecke in Lehre und Forschung sowie für die private Nutzung frei zur Verfügung. Einzelne Dateien oder Ausdrucke aus diesem Angebot können zusammen mit diesen Nutzungsbedingungen und den korrekten Herkunftsbezeichnungen weitergegeben werden.

Das Veröffentlichen von Bildern in Print- und Online-Publikationen ist nur mit vorheriger Genehmigung der Rechteinhaber erlaubt. Die systematische Speicherung von Teilen des elektronischen Angebots auf anderen Servern bedarf ebenfalls des schriftlichen Einverständnisses der Rechteinhaber.

## **Haftungsausschluss**

Alle Angaben erfolgen ohne Gewähr für Vollständigkeit oder Richtigkeit. Es wird keine Haftung übernommen für Schäden durch die Verwendung von Informationen aus diesem Online-Angebot oder durch das Fehlen von Informationen. Dies gilt auch für Inhalte Dritter, die über dieses Angebot zugänglich sind.

# EPIPHYTIC BRYOPHYTE COMMUNITIES OF *OLEA EUROPAEA* IN PORTUGAL – A BACKGROUND SURVEY FOR FUTURE EVALUATION OF ENVIRONMENTAL QUALITY

MANUELA SIM-SIM<sup>\*</sup>, FRANCISCO REGO<sup>•</sup> & JORGE DE SOUSA<sup>#</sup>

<sup>\*</sup>Departamento de Biologia Vegetal, Faculdade de Ciências de Lisboa. R. Escola Politécnica 58, P-1294 Lisboa Codex, Portugal

<sup>•</sup>Instituto Superior de Agronomia, Tapada de Ajuda, P-1300 Lisboa, Portugal

<sup>#</sup>Instituto Superior Técnico, Av. Róuisco Pais, P-1096 Lisboa, Portugal

**SUMMARY**— *The epiphytic bryophyte vegetation in semi-natural undisturbed communities of Olea europaea in Portugal and its dependence on a number of climatic and environmental variables were investigated in 178 stands situated all over the country. 68 bryophyte taxa were found and 16 both climatic and environmental variables were recorded. Using TWINSpan analysis, four species groups and their indicator species could be recognised. A Detrended Canonical Correspondance Analysis showed that altitude and some temperature variables are strongly correlated with the first axis. Gaussen xerothermic index, evapotranspiration, precipitation and hydric index are closely associated with axis 2. Atlantic and hyperatlantic areas are characterized by species such as Cololejeunea minutissima, Cryphaea heteromalla, Lejeunea cavifolia, Metzgeria conjugata, Radula complanata, Rhynchostegiella tenella and Sematophyllum substrumulosum. Species distribution is correlated with the climate in altitudes above 500 m. Frullania fragilifolia, Metzgeria furcata, Neckera pumila, Orthotrichum striatum, Porella platyphylla and Ulota crispa, occur in stands with distinctly higher precipitation levels, corresponding to mountainous regions under atlantic influence. Antitrichia californica, Claopodium whippleanum, Hedwigia ciliata, Orthotrichum affine, Tortula latifolia, T. papillosa and Zygodon conoideus, are characteristic of high altitudes in continental regions. Some taxa which are continuously distributed all over the country, e.g., Frullania dilatata, Homalothecium sericeum, Hypnum cupressiforme and Tortula laevipila, can be used for future evaluation of environmental quality. The distribution of Frullania dilatata which is still abundant in Portugal is presented as an example. The results of the study yield a zonation of the different epiphytic species assemblages of Olea europaea in Portugal.*

**KEYWORDS**— *Climatic variables, environmental variables, cluster analysis, canonical correspondence analysis, bioindication*

**ZUSAMMENFASSUNG**— *Epiphytische Moosgesellschaften an Olea europaea in Portugal — Eine Grundlagen-Untersuchung für künftige Beurteilung der Umweltqualität*

*Die epiphytische Moosvegetation in naturnahen ungestörten Olea-europaea-Gesellschaften Portugals und ihre Abhängigkeit von verschiedenen Klima- und Umweltfaktoren wurden an 178 über das ganze Land verteilten Beständen untersucht. 68 Moos-Taxa wurden dabei gefunden, und 16 Variable des Klimas und der Umwelt wurden erfasst. Mittels TWINSpan-Analyse konnten vier Artengruppen und ihre Zeigerarten ermittelt werden. Eine 'Detrended Canonical Correspondence Analysis' zeigte, dass Höhenlage und einige Temperatur-Parameter stark mit der ersten Achse korreliert sind. Die zweite Achse zeigt enge Beziehungen zum Xerothermischen Index nach Gaussen, zur Evapotranspiration, zu den Niederschlägen und zum 'hydric index'. Atlantische und hyperatlantische Gebiete sind charakterisiert durch Arten wie Cololejeunea minutissima, Cryphaea heteromalla, Lejeunea cavifolia, Metzgeria conjugata, Radula complanata, Rhynchostegiella tenella und Sematophyllum substrumulosum. Oberhalb 500 m ü. M. ist die Verbreitung der Arten mit dem Klima korreliert. Frullania fragilifolia, Metzgeria furcata, Neckera pumila, Orthotrichum striatum, Porella platyphylla und Ulota crispa kommen an Standorten mit deutlich höheren Niederschlägen vor, wie sie sich in Gebirgen unter atlantischem Einfluss finden. Antitrichia californica, Claopodium whippleanum, Hedwigia ciliata, Orthotrichum affine, Tortula latifolia, T. papillosa und Zygodon conoideus sind charakteristisch für hochgelegene kontinentale Gebiete. Einige Taxa, die durchgehend im ganzen Land verbreitet sind, z. B. Frullania dilatata, Homalothecium sericeum, Hypnum cupressiforme und Tortula laevipila, können für die künftige Beurteilung der Umweltqualität verwendet werden. Als Beispiel wird die Verbreitung von Frullania dilatata, die in Portugal noch in grosser Men-*

ge vorhanden ist, vorgestellt. Die Ergebnisse der Untersuchung liefern eine Zonierung der verschiedenen epiphytischen Artenkombinationen auf *Olea europaea* in Portugal.

**Introduction**

Renewed interest in cryptogamic epiphytes, both bryophytes and lichens, is evidenced by much recent research, especially in North America and Europe. In part, this has been a result

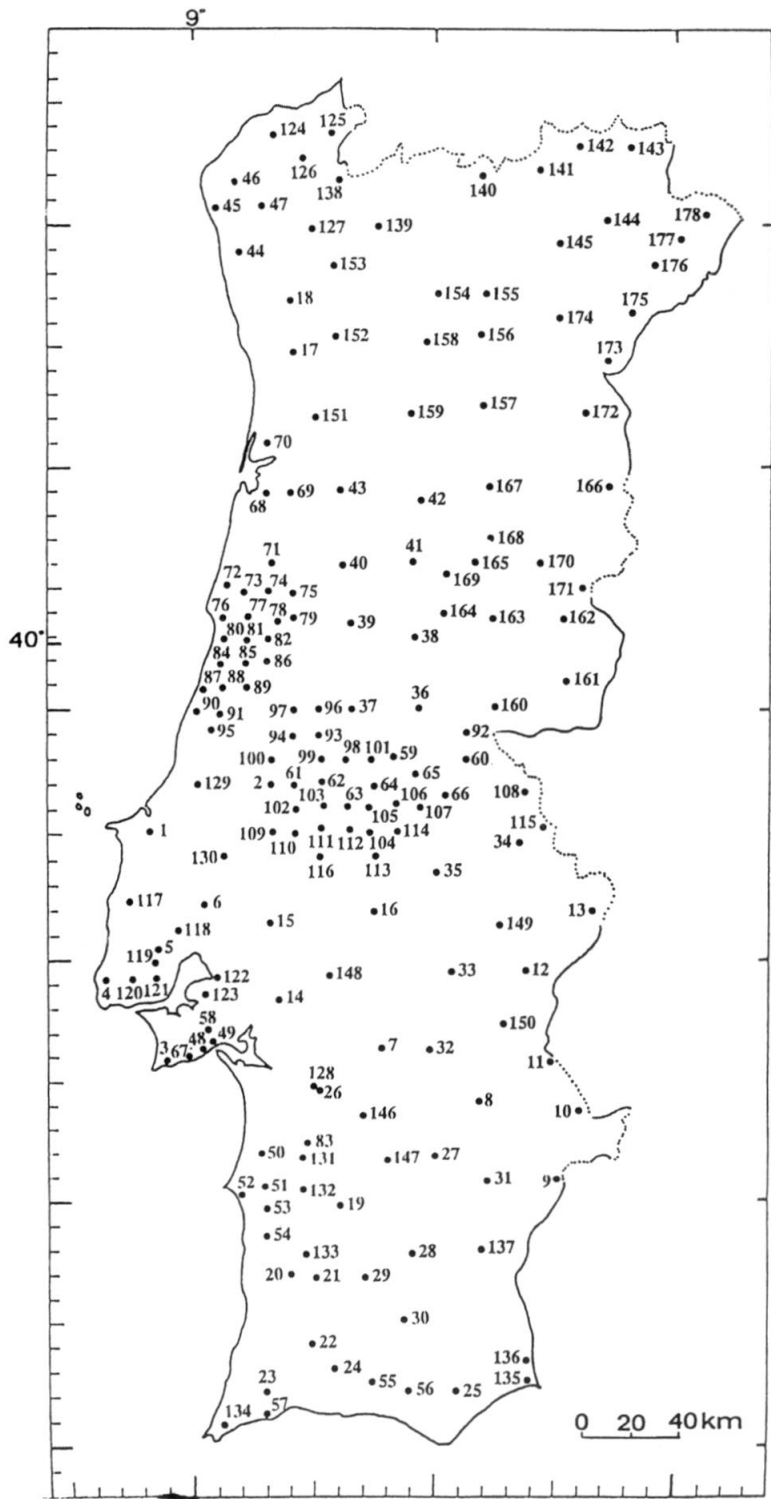

**FIGURE 1.** Location of the 178 stands studied in Portugal, using a grid of 10 x 10 km.

of the wide recognition of the susceptibility of these epiphytes to air pollution and the knowledge of the drastic effects of human activities on this flora. Base-line studies in relatively unpolluted areas are therefore important (Schmitt & Slack 1990, Sigal & Nash III 1990). Considering that quantitative and qualitative studies of the epiphytic communities are rare, the study of bryophyte distribution and the factors which may affect it will constitute a data base for future evaluation of main changes in this sensitive vegetation.

An investigation of the epiphytic communities of *Olea europaea* in Portugal showed that many of its constituent species resemble the *Lobarion pulmonariae* lichen alliance (James & al. 1977, Rose 1992). The decline of *Lobarion* in Europe has been attributed to losses of species highly sensitive to SO<sub>2</sub> pollution, the influence of herbicides, and excessive eutrophication due to the use of artificial fertilizers in a spray or a powder form (Bates 1992, Rose 1992). Nevertheless, apparently little information is available concerning the natural environmental requirements, both biotic and abiotic, of individual species and species assemblages of epiphytes. Therefore, it would be advantageous to obtain such information in areas free from heavy atmospheric pollution.

The goal of the present study is therefore to recognize the major features of epiphyte community variation and its underlying causes. On the other hand, the recognition of indicator species is a useful assessment of the conservation interest of a site (Hallingbäck 1991).

## Study area and methods

The study area covers all Portugal comprising a surface of 92000 km<sup>2</sup>. The main mountain ranges are located on the northeastern and northwestern part of Portugal. Maximum elevations are in the northern central part, with elevations up to 2000 m. The climate of Portugal is generally of a mediterranean type combined with a strong atlantic influence. The mean temperature of the hottest month is not greater than 22 °C and depends on the effect of oceanic air masses and altitude. During 1991 and 1992, 178 stands were investigated. The stands for study were selected using a grid of 10 x 10 km so that each square of 30 x 30 km was represented by at least one stand (Fig. 1). A narrower grid was chosen in areas where industrial complexes were planned to be built, in order to evaluate the impact of future industrial activities on the epiphytic vegetation.

All study stands are located in flat areas of natural and semi-natural vegetation, at distances of at least 100 m from secondary roads or 500 m from main roads. Industrial complexes, urban areas and rural complexes were also avoided. The phorophyte chosen was *Olea europaea*, a commonly planted tree, generally free from chemical treatment, presenting a regular and homogeneous distribution in all country and being limited to altitudinal levels below 1000 m due to climatic and geomorphological conditions.

Meteorological data were obtained from 30 year means (1951-80, Instituto Nacional de Meteorologia e Geofisica 1990-1991). The following climatic variables were used for each stand: 1) Precipitation, calculated as the total amount of rainfall during the growing season; 2) number of precipitation days, which equals the number of days with rainfall during the growing season; 3) mean annual temperature; 4) maximum mean temperature for the hottest month; 5) minimum mean temperature for the coldest month; 6) cloudiness; 7) mean real evapotranspiration (Casimiro Mendes & Bettencourt 1980); 8) air humidity; 9) Specht evaporative coefficient (Loureiro 1990); 10) winter type (Daveau 1985). Several indices using both temperature and hydric measurements were also used: 11) thermopluviometric index according to Emberger (Alcoforado & al. 1982); 12) xerothermic coefficient according to Gaussen (Alcoforado & al. 1982), and 13) hydric index (Casimiro Mendes & Bettencourt 1980).

The environmental variables used for each stand were: 1) altitude; 2) mean bryophyte cover, expressed as % of the total area of trunks examined in each stand; 3) the main vascular plant vegetation units for stand characterisation from a vegetation map of Portugal (Atlas do Ambiente 1984).

In each stand, ten olive tree-trunks were examined from the base to a height of 1.7 m on all exposures. Vigour-vitality and sociability of each species were recorded according to semi-quantitative scales (Bento-Pereira & Sérgio 1983). This is considered reasonable as the large majority of phorophytes were examined by the same person.

For vitality two classes were considered: 3- plants in good vegetative condition, no sexual reproduction and, 4- plants in good vegetative condition, sexual reproduction present. For sociability the following classes were considered: 1- one colony (tuft) smaller than 10 cm<sup>2</sup>; 2- one colony (tuft) larger than 10 cm<sup>2</sup> or two colonies smaller than 10 cm<sup>2</sup>; 3- several colonies (tufts) smaller than 10 cm<sup>2</sup>; 4- several colonies (tufts) larger than 10 cm<sup>2</sup> and smaller than 100 cm<sup>2</sup>; 5- one colony (tuft) of the same species larger than 100 cm<sup>2</sup>.

Species abundances were subjected to a TWINSpan analysis, a divisive hierarchical method that produces a two-way classification of species and stands (Hill 1979). Five cut levels were used: 0.5, 1.5, 2.5, 3.5 and 4.5. Species abundance and environmental and climatic variables were ordinated simultaneously using Detrended Canonical Correspondence Analysis (DCCA, ter Braak 1987-92). Detrending was by 2<sup>nd</sup> order polynomials and rare taxa were not downweighted in the DCCA. Data from all 178 stands were used in both analyses.

Nomenclature follows Corley & al. (1981) and Corley & Crundwell (1991) for mosses except for *Dialytrichia mucronata* (Sérgio & Sim-Sim 1984) and Grolle (1983) for hepatics, except for *Frullania dilatata* var. *elongata* (Losada Lima & Vanden-Berghen 1985).

## Results and Discussion

Fifteen hepatic taxa and 53 moss taxa were found in the investigated stands. The first and second TWINSpan division separate the 68 taxa and 178 stands into four major groups (1(A, B), 2, 3 and 4) based on species abundance within each stand. Fig. 2 shows the TWINSpan division until the 3rd level, along with the indicator species for each group.

The DCCA biplots of axes 1 and 2 (Figs 3 & 4) can be used to assess the influence of environmental and climatic gradients on the distribution of individual species. The distances between the arrows representing the climatic and environmental variables and the species position in the ordination diagram permit an approximate determination of the importance of these variables in influencing the distribution of individual species (Jongman & al. 1987).

The amount of variation accounted for by the two first DCCA axes is 24.2% and 19.5%, respectively. The tips of the arrows indicate the position of each environmental variable, the length and proximity to the axis of the arrow show the relative weight of each variable in determining the axes (ter Braak 1987-92). All environmental and most of the climatic variables are significantly correlated with axis 1 ( $p < 0.05$ ). Many climatic variables are strongly positively correlated with axis 1, while some exhibit a negative correlation. The Gaussen xerothermic index, evapotranspiration, precipitation, and hydric index are the only variables

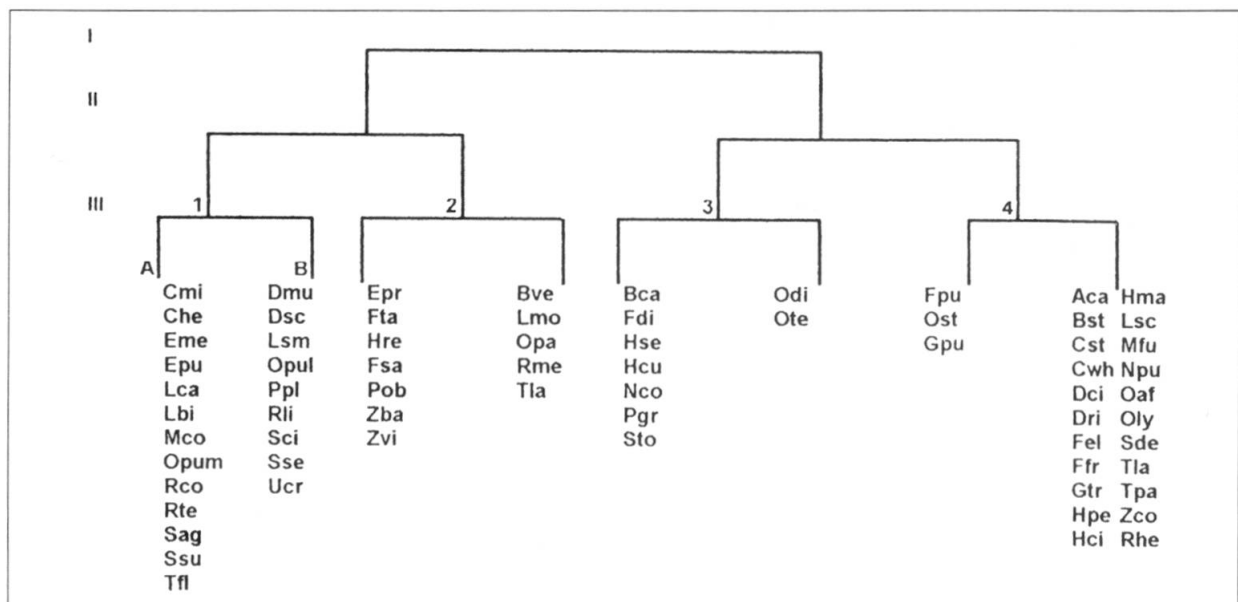

**FIGURE 2.** Dendrogram representing the major divisions of TWINSpan classification of the epiphytic species groups from *Olea europaea* in Portugal, based on species abundance. Four final groups are recognized (1(A, B), 2, 3 and 4) until the 3<sup>rd</sup> level. Abbreviations: Hepatics: Cmi=*Cololejeunea minutissima*; Cse=*Cephaloziella stellulifera*; Fdi=*Frullania dilatata*; Fel=*Frullania dilatata* var. *elongata*; Ffr=*Frullania fragilifolia*; Fta=*Frullania tamarisci* var. *tamarisci*; Fsa=*Frullania tamarisci* var. *sardoa*; Lbi=*Lophocolea bidentata*; Lca=*Lejeunea cavifolia*; Mco=*Metzgeria conjugata*; Mfu=*Metzgeria furcata*; Pob=*Porella obtusata*; Ppl=*Porella platyphylla*; Rco=*Radula complanata*; Rli=*Radula lindenbergiana*. Mosses: Aca=*Antitrichia californica*; Bst=*Bartramia stricta*; Bve=*Brachythecium velutinum*; Bca=*Bryum capillare*; Cwh=*Claopodium whippleanum*; Che=*Cryphaea heteromalla*; Dmu=*Dialytrichia mucronata*; Dci=*Dicranoweisia cirrata*; Dsc=*Dicranum scoparium*; Dri=*Didymodon rigidulus*; Eme=*Eurhynchium meridionale*; Epr=*Eurhynchium praelongum*; Epu=*Eurhynchium pulchellum*; Fpu=*Fabronia pusilla*; Gpu=*Grimmia pulvinata*; Gtr=*Grimmia trichophylla*; Hpe=*Habrodon perpusillus*; Hci=*Hedwigia ciliata*; Hse=*Homalothecium sericeum*; Hma=*Hypnum mamillatum*; Hcu=*Hypnum cupressiforme*; Hre=*Hypnum resupinatum*; Lmo=*Leucodon sciuroides* var. *morensis*; Lsc=*Leucodon sciuroides* var. *sciuroides*; Lsm=*Leptodon smithii*; Nco=*Neckera complanata*; Npu=*Neckera pumila*; Oaf=*Orthotrichum affine*; Odi=*Orthotrichum diaphanum*; Oly=*Orthotrichum lyellii*; Opa=*Orthotrichum pallens*; Opul=*Orthotrichum pulchellum*; Opum=*Orthotrichum pumilum*; Ost=*Orthotrichum stramineum*; Ote=*Orthotrichum tenellum*; Pgr=*Pterogonium gracile*; Rhe=*Racomitrium heterostichum*; Rme=*Rhynchostegium megapolitanum*; Rte=*Rhynchostegiella tenella*; Sag=*Schistidium agassizii*; Sto=*Scleropodium touretii*; Sci=*Scorpiurium circinatum*; Sde=*Scorpiurium deflexifolium*; Sse=*Scorpiurium sendtneri*; Ssu=*Sematophyllum substrumulosum*; Tla=*Tortula laevipila*; Tla=*Tortula latifolia*; Tpa=*Tortula papillosa*; Tfl=*Tortella flavovirens*; Ucr=*Ulota crispa*; Zba=*Zygodon baumgartneri*; Zco=*Zygodon conoideus*; Zvi=*Zygodon viridissimus*.

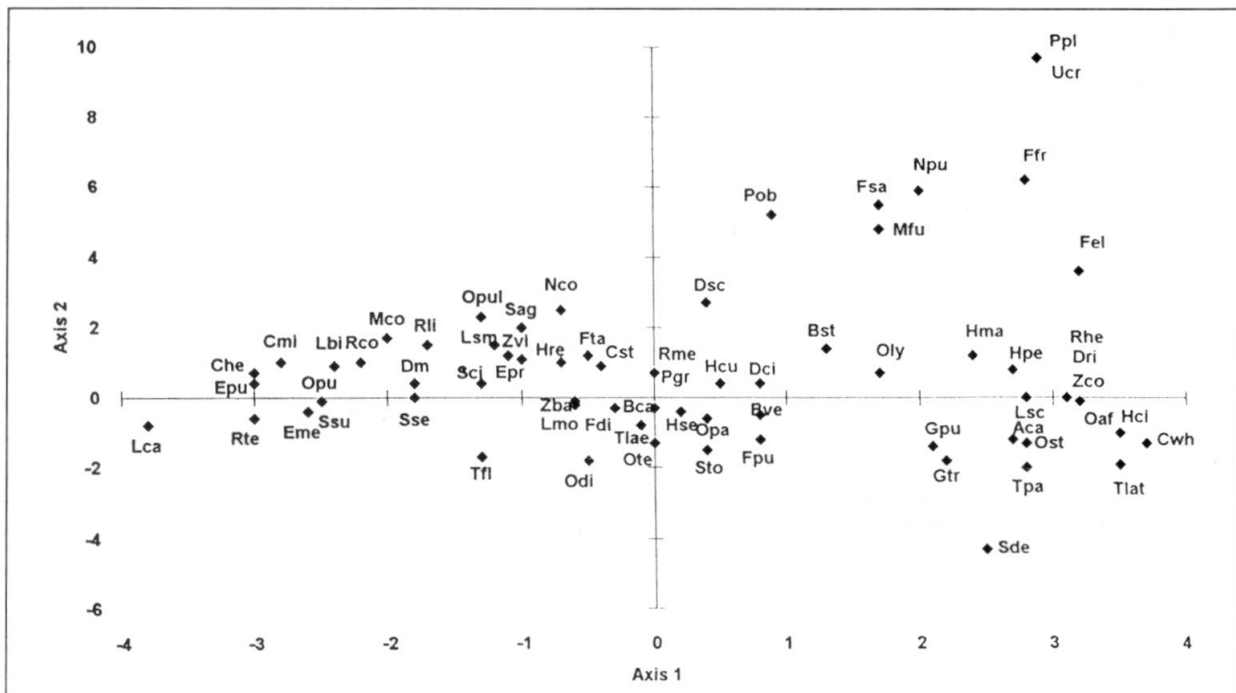

**FIGURE 3.** Ordination diagram of species scores on axes 1 and 2, based on DCCA of bryophyte assemblages on *Olea europaea* stands in Portugal. Abbreviations as in Fig. 2.

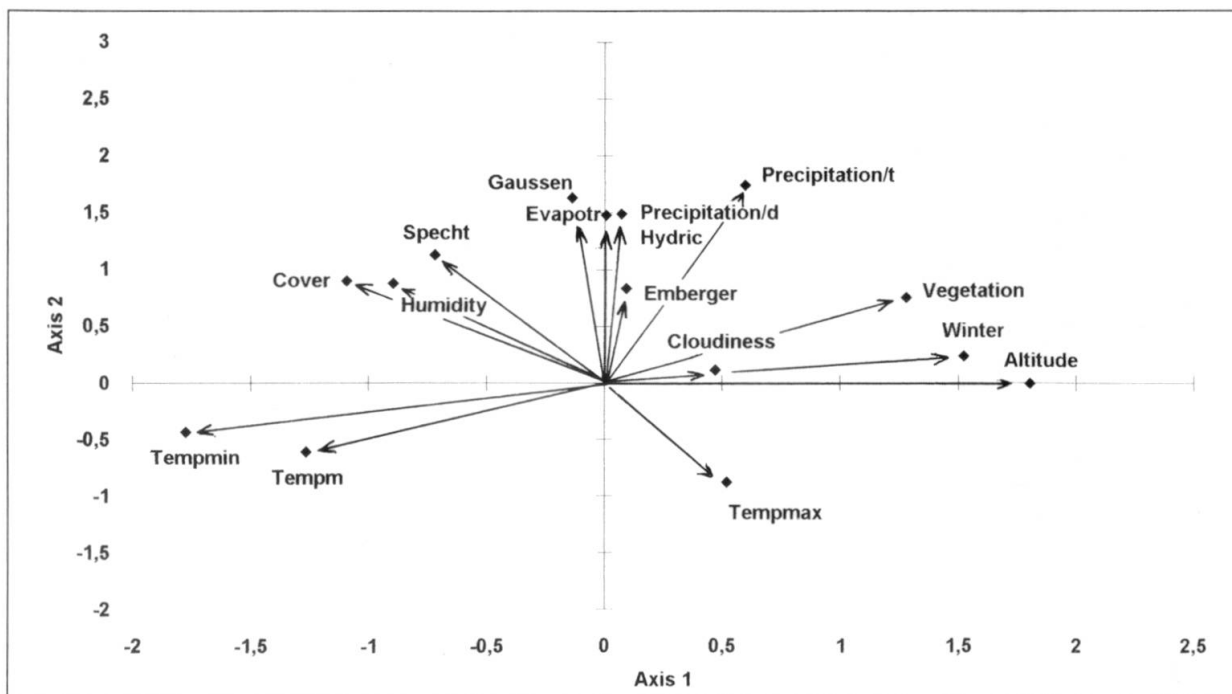

**FIGURE 4.** DCCA biplot of the environmental variables (arrows). Abbreviations: Cover=mean bryophyte cover; Emberger=thermopluviometric index according to Emberger; Evapotr=evapotranspiration potential; Gausсен=xerothermic coefficient according to Gausсен; Hydric=hydric index; Precipitation/t=total precipitation; Precipitation/d=number of precipitation days; Specht=Specht evaporative coefficient; Tempm=mean annual temperature; Tempmax=temperature maximum for the hottest month; Tempmin=temperature minimum for the coldest month; Vegetation=vegetation units; Winter=winter type.

considered that are closely related to axis 2. The Emberger thermopluviometric index, cloudiness, and maximum mean temperature of the hottest month are not strongly influential in determining either axis.

*Cololejeunea minutissima*, *Cryphaea heteromalla*, *Eurhynchium meridionale*, *E. pulchellum*, *Lejeunea cavifolia*, *Lophocolea bidentata*, *Metzgeria conjugata*, *Orthotrichum pumilum*, *Radula complanata*, *Rhynchostegiella tenella* and *Sematophyllum substrumosum* of group 1 (A and B, Fig. 2), are found exclusively in atlantic and hyperatlantic areas (Figs 3 & 6). These species are probably restricted to those regions due to climate which is partly depending on altitude.

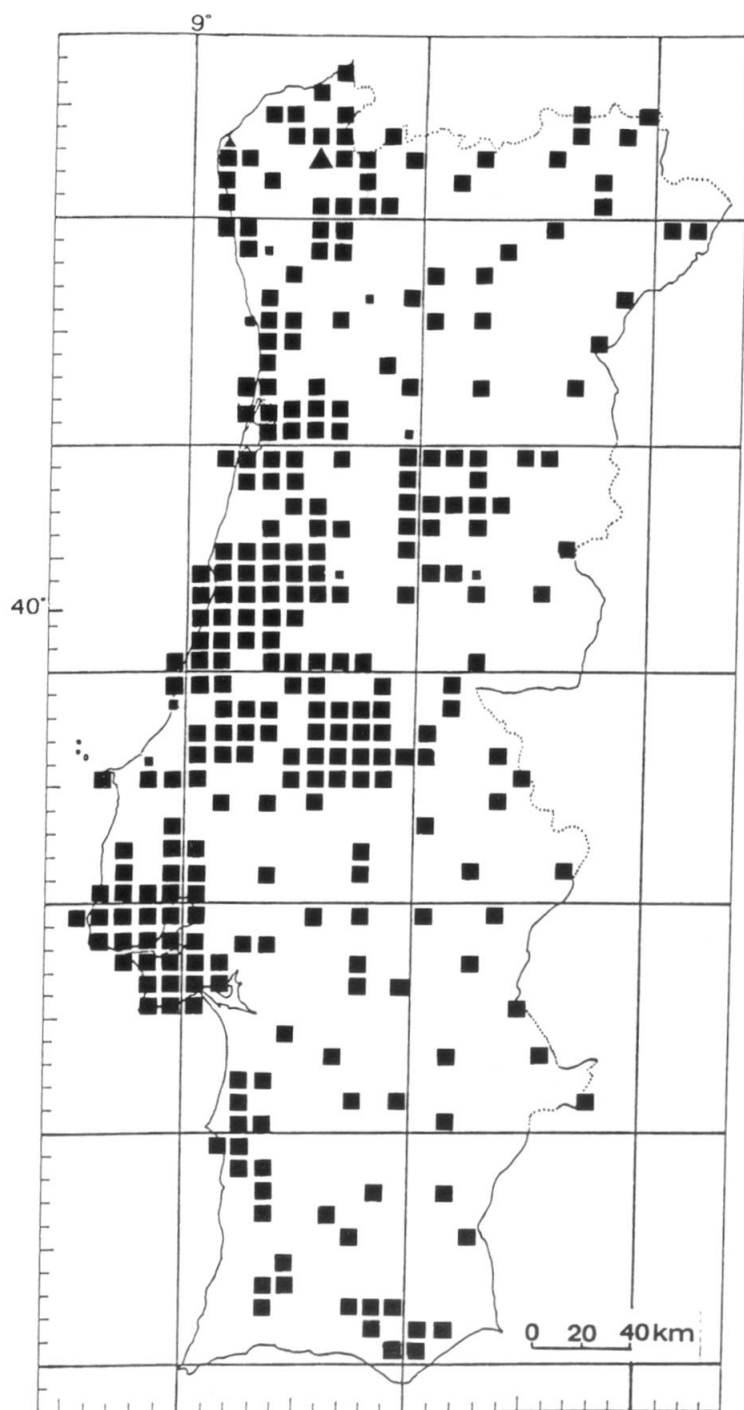

FIGURE 5. Distribution of *Frullania dilatata* in Portugal using a grid of 10 x 10 km. ■ ■ herbarium records since and before 1950; ▲ ▲ literature references since and before 1950.

Groups 2 and 3 have an intermediate position on the DCCA biplot between the atlantic and the continental species. These species occupy a narrow portion of the climatic gradient from atlantic (group 2) to subcontinental sites (group 3, Fig. 6), but are excluded from continental localities. They also appear to be limited by climate, but their physiological tolerances along this gradient are wider than those of group 1.

The distribution of species positioned around the origin of the first axis is not strongly influenced by climatic and environmental variables. These species are widespread and common throughout the country, both on rock and bark. Examples are *Frullania dilatata* (Fig. 5), *Homalothecium sericeum*, *Hypnum cupressiforme*, *Leucodon sciuroides* var. *morensis*, *Pterogonium gracile*, *Scleropodium touretii* and *Tortula laevipila*.

The DCCA ordination of the species indicates that most epiphytes in group 4 are restricted to communities at altitudes above 500 m. Among these species, distributions are more a function of the climate rather than of altitude. The biplot indicates that species on the positive side of axis 2 (Fig. 3), like *Frullania fragilifolia*, *Metzgeria furcata*, *Neckera pumila*, *Orthotrichum striatum*, *Porella platyphylla*, *P. obtusata* and *Ulota crista*, occur in stands with distinctly higher precipitation levels than the remaining species, corresponding in part, to mountainous regions with an atlantic influence. On the other hand, species on the negative side of axis 2, like *Antitrichia californica*, *Claopodium whippleanum*, *Hedwigia ciliata*, *Orthotrichum affine*,

*Tortula latifolia*, *T. papillosa* and *Zygodon conoideus* are characteristic of continental regions of high altitudes. In interior areas where the range of altitude and mean maximum temperature of the hottest month extend to high values (represented on the negative side of axis 2), the DCCA ordination plot clearly demonstrates that hepatic species are almost completely replaced by mosses.

The *Lobarion pulmonariae* which is mainly composed of large foliose lichens and robust bryophytes is shown to be relatively sensitive to acidic pollutants (Farmer & al. 1992). Many bryophyte species present in communities of this alliance, such as *Frullania fragilifolia*, *F. tamarisci*, *Homalothecium sericeum*, *Neckera complanata*, *N. pumila*, *Orthotrichum lyellii*, *Pterogonium gracile* and *Zygodon baumgartneri* showed relatively high constancy over the whole geographical range of the alliance in Portugal, which is mainly oceanic-mediterranean. Some affinities were found due to the occurrence of species such as *Cryphaea heteromalla*, *Orthotrichum pumilum*, *Porella platyphylla*, *Radula complanata*, *Tortula laevipila* and *Zygodon baumgartneri*, with the *Radulo-Cryphaeetum heteromallae* of forest regions with atlantic-mediterranean tendencies (Lecoite 1975).

In conclusion, altitude, precipitation and temperature gradients are the most important factors limiting the distribution of individual epiphytic species on *Olea europaea* in Portugal. The distribution of several elements (e.g., group 1) are restricted to oceanic habitats due to climate. The distributions of species of groups 2 and 3 are limited to high altitudinal levels and have continental tendencies, although it is not clear whether the climate or the absence of suitable habitats in the atlantic area is limiting their geographic distribution.

It is interesting to notice that species usually confined to more or less moist substrates in temperate and boreal regions, may occur in oceanic areas on apparently dry substrate, as pointed out by Sérgio & al. (1994). The excess of rain water or fog compensates for the water deficit in the substrate. Such is the case for *Dialytrichia mucronata*, *Grimmia* spp., *Hedwigia ciliata* and *Scorpiurium circinatum* which appear in saxicolous and epiphytic communities.

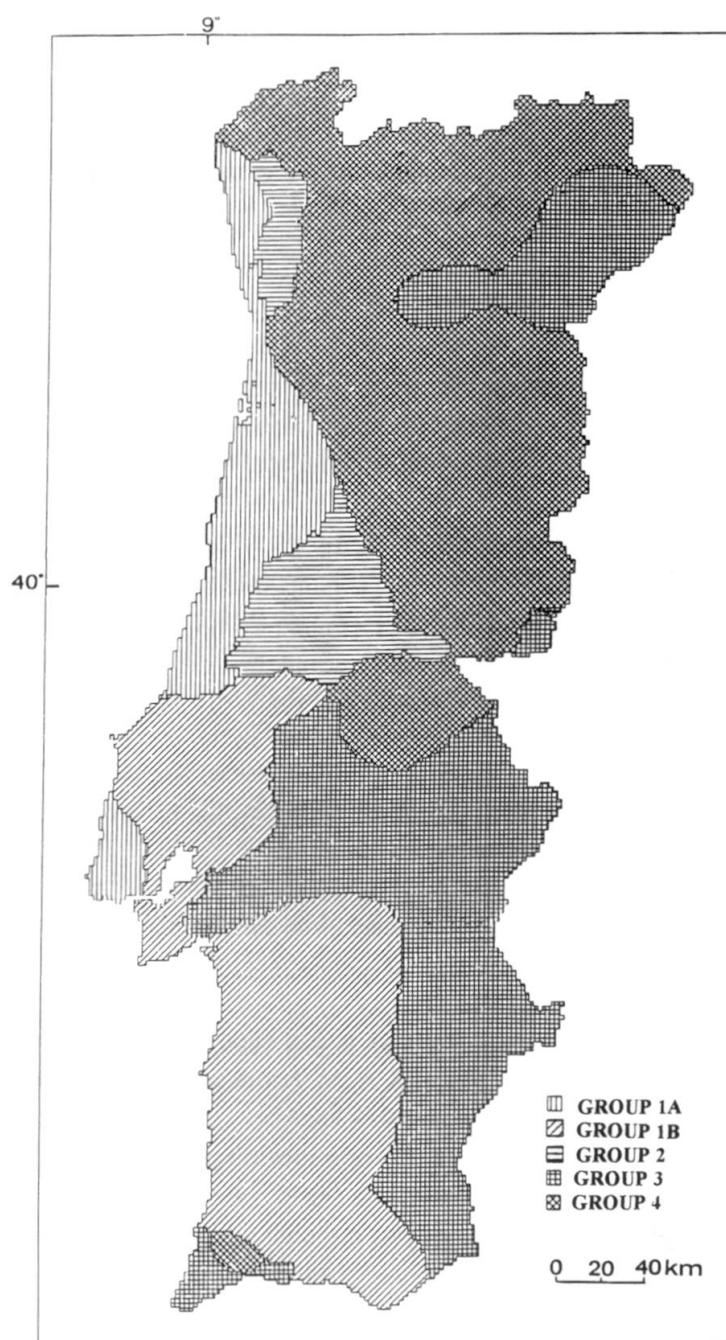

FIGURE 6. Zonation of the main epiphytic bryophyte assemblages of *Olea europaea* in Portugal. Species composition of groups 1 to 4 see Fig. 2.



This study permits the selection not only of the species sensitive to some climatic parameters, but also of widespread taxa such as *Frullania dilatata* that may be important for future evaluation of environmental conditions. Fig. 5 shows the distribution of *Frullania dilatata* in Portugal, one of the most frequent epiphytes in the country. The species proved also to be a very good indicator of heavy metal levels in Portugal (Sérgio & al. 1993), supporting SO<sub>2</sub> winter concentrations up to 70 mg/m<sup>3</sup> (Sérgio & Sim-Sim 1983). It can thus be used to detect changes in air quality and community structure. In addition, the disappearance of a few species characteristic of groups 1 or 4 may indicate alterations in some epiphytic communities.

The results of this study yield a zonation of the different epiphytic species assemblages of *Olea europaea* in Portugal (Fig. 6). Each different area corresponds to a species group represented in Fig. 2. Alterations in the community structure due to changes in environmental conditions are predictable through this ordination model.

## Acknowledgements

We are grateful to Dr. C. Sérgio for her assistance during field work. We also thank to Dr. P.M. Jones for linguistic revision of the text, Dr. I. Bisang for helpful comments on an earlier version of the manuscript, and to anonymous reviewers.

## References

- Alcoforado M. J., M. F. Alegria, A. R. Pereira & C. Sirgado 1982. Domínios bioclimáticos em Portugal definidos por comparação dos índices de Gaussen e de Emberger. Relatório nº 14, Centro de Estudos Geográficos, Lisboa.
- Atlas do Ambiente 1984. Carta Ecológica. Comissão Nacional do Ambiente. Escala 1:1 000 000, Lisboa.
- Bates J. W. 1992. Influence of chemical and physical factors on *Quercus* and *Fraxinus* epiphytes at Loch Sunart, western Scotland: a multivariate analysis. *J. Ecol.* 80: 163-179.
- Bento-Pereira F. & C. Sérgio 1981. Líquenes e briófitos como bioindicadores da poluição atmosférica – II. Utilização de uma escala quantitativa para Lisboa. *Revista Biol. (Lisboa)* 12: 297-312.
- Casimiro Mendes J. & M. L. Bettencourt 1980. O clima de Portugal. XXIV – Contribuição para o estudo do balanço climatológico de água no solo e classificação climática de Portugal Continental. Instituto Nacional de Meteorologia e Geofísica, Lisboa.
- Corley M. F. V. & A. C. Crundwell 1991. Additions and amendments to the mosses of Europe and the Azores. *J. Bryol.* 16: 337-356.
- Corley M. F. V., A. C. Crundwell, R. Düll, M. O. Hill & A. J. E. Smith 1981. Mosses of Europe and the Azores; an annotated list of species, with synonyms from the recent literature. *J. Bryol.* 11: 609-689.
- Daveau S. 1977. Répartition et rythme des précipitations au Portugal. Memória nº 3, Centro de Estudos Geográficos, Lisboa.
- Farmer A. M., J. W. Bates & J. N. B. Bell 1992. Ecophysiological effects of acid rain on bryophytes and lichens. In: J. W. Bates & A. M. Farmer (eds). *Bryophytes and lichens in a Changing Environment*. Clarendon Press, Oxford, 282-311.
- Grolle R. 1983. Hepatics of Europe including the Azores: an annotated list of species, with synonyms from the recent literature. *J. Bryol.* 12: 403-459.
- Hallingbäck T. 1991. Bryophytes indicating high nature conservation values in Swedish woodland sites. *Svensk. Bot. Tidskr.* 85, 5: 321-332.
- Hill M. O. 1979. TWINSpan - a FORTRAN Program for Arranging Multivariate Data in an Ordered Two-way Table by Classification of the Individuals and Attributes. Cornell University, Ithaca NY.
- Instituto Nacional de Meteorologia e Geofísica 1990. O clima de Portugal. XLIX, 1 – Normais Climatológicas da região de 'Entre Douro e Minho e Beira Litoral', correspondentes a 1951-80. Lisboa.

- Instituto Nacional de Meteorologia e Geofísica 1991.** *O clima de Portugal. XLIX, 2 – Normais Climatológicas da região de 'Ribatejo e Oeste', correspondentes a 1951-80.* Lisboa.
- Instituto Nacional de Meteorologia e Geofísica 1991.** *O clima de Portugal. XLIX, 3 – Normais Climatológicas da região de 'Trás-os-Montes e Alto Douro e Beira Interior', correspondentes a 1951-80.* Lisboa.
- Instituto Nacional de Meteorologia e Geofísica 1991.** *O clima de Portugal. XLIX, 4 – Normais Climatológicas da região de 'Alentejo e Algarve', correspondentes a 1951-80.* Lisboa.
- James P. W., D. L. Hawksworth & F. Rose 1977.** Lichen communities in the British Isles: a preliminary conspectus. In: M. R. D. Seaward (ed.). *Lichen Ecology.* Academic Press, London, 200-258.
- Jongman R. H. G., C. J. F. ter Braak & O. F. R. Tongeren 1987.** *Data analysis in community and landscape ecology.* Centre for Agricultural Publishing and Documentation, Wageningen.
- Lecoite A. 1975.** Étude phytosociologique des groupements de bryophytes épiphytes de la Brenne (Indre-France). *Doc. Phytosociol.* 9-14: 165-195.
- Losada-Lima A. & G. Vanden-Berghen 1985.** *Frullania dilatata* (L.) Dum. var. *elongata* var. nov. (Hepaticae). *Vieraea* 15, 1-2: 3-6.
- Loureiro N. M. F. S. 1990.** *Alguns indicadores morfoestruturais e teores de nutrientes foliares em Quercus suber L. e Arbutus unedo L., estimados em Portugal Continental, e correlacionados com o coeficiente evaporativo de Specht.* Tese para a obtenção do grau Master of Science, Zaragoza.
- Rose F. 1992.** Temperate forest management: its effects on bryophyte and lichen floras and habitats: In: J. W. Bates & A. M. Farmer (eds). *Bryophytes and Lichens in a Changing Environment.* Clarendon Press, Oxford, 148-160.
- Schmitt C. K. & N. G. Slack 1990.** Host specificity of epiphytic lichens and bryophytes: A comparison of the Adirondack Mountains (New York) and the Southern Blue Ridge Mountains (North Carolina). *Bryologist* 93, 3: 257-274.
- Sérgio C., C. Casas, M. Brugués & R. M. Cros 1994.** *Lista Vermelha dos Briófitos da Península Ibérica. [Red List of Bryophytes of the Iberian Peninsula].* Instituto de Conservação da Natureza, Lisboa.
- Sérgio C. & M. Sim-Sim 1983.** Estudo da poluição atmosférica no estuário do Tejo. A vegetação epifítica como bioindicadora. *Portug. Acta Biol. B.* 14: 213-244.
- Sérgio C. & M. Sim-Sim 1984.** *Dialytrichia mucronata* (Brid.) Broth. au Portugal et à Madère. Taxonomie, écologie, adaptation à la sécheresse. *Cryptogamie, Bryol. Lichénol.* 5, 1-2: 87-98.
- Sérgio C., M. Sim-Sim & R. Figueira 1993.** *Quantificação da deposição de metais pesados em Portugal, através da análise de briófitos. Apresentação dos resultados finais de um programa piloto para Portugal.* Direcção Geral da Qualidade do Ambiente, Lisboa.
- Sigal L. L. & T. N. Nash III 1983.** Lichen communities on conifers in the southern mountains: an ecological survey relative to oxidant air pollution. *Ecology* 64, 6: 1343-1354.
- ter Braak C. J. F. 1987-1992.** *CANOCO - a FORTRAN program for canonical community ordination by [partial] [detrended] [canonical] correspondence analysis, principal components analysis and redundancy analysis (version 2.1).* Microcomputer Power, Ithaca NY.

