

# HARTREE'S THEOREM ON EXISTENCE OF THE QUANTUM DEFECT

Autor(en): **KOOSIS, Paul**

Objektyp: **Article**

Zeitschrift: **L'Enseignement Mathématique**

Band (Jahr): **46 (2000)**

Heft 1-2: **L'ENSEIGNEMENT MATHÉMATIQUE**

PDF erstellt am: **13.09.2024**

Persistenter Link: <https://doi.org/10.5169/seals-64799>

## **Nutzungsbedingungen**

Die ETH-Bibliothek ist Anbieterin der digitalisierten Zeitschriften. Sie besitzt keine Urheberrechte an den Inhalten der Zeitschriften. Die Rechte liegen in der Regel bei den Herausgebern. Die auf der Plattform e-periodica veröffentlichten Dokumente stehen für nicht-kommerzielle Zwecke in Lehre und Forschung sowie für die private Nutzung frei zur Verfügung. Einzelne Dateien oder Ausdrucke aus diesem Angebot können zusammen mit diesen Nutzungsbedingungen und den korrekten Herkunftsbezeichnungen weitergegeben werden. Das Veröffentlichen von Bildern in Print- und Online-Publikationen ist nur mit vorheriger Genehmigung der Rechteinhaber erlaubt. Die systematische Speicherung von Teilen des elektronischen Angebots auf anderen Servern bedarf ebenfalls des schriftlichen Einverständnisses der Rechteinhaber.

## **Haftungsausschluss**

Alle Angaben erfolgen ohne Gewähr für Vollständigkeit oder Richtigkeit. Es wird keine Haftung übernommen für Schäden durch die Verwendung von Informationen aus diesem Online-Angebot oder durch das Fehlen von Informationen. Dies gilt auch für Inhalte Dritter, die über dieses Angebot zugänglich sind.

**Vide-leer-empty**

## HARTREE'S THEOREM ON EXISTENCE OF THE QUANTUM DEFECT

by Paul KOOSIS

### INTRODUCTION

In terms of atomic (Hartree) units, the Schrödinger equation for hydrogen reads thus :

$$(1) \quad \nabla_X^2 \psi(X) + \left( \frac{2}{|X|} - \lambda \right) \psi(X) = 0.$$

Here,  $X$  denotes the point  $(x, y, z)$ ,  $|X| = \sqrt{x^2 + y^2 + z^2}$ , and

$$\nabla_X^2 = \frac{\partial^2}{\partial x^2} + \frac{\partial^2}{\partial y^2} + \frac{\partial^2}{\partial z^2}$$

is the Laplacian. The potential energy due to attraction between the electron and the nucleus is represented by  $-1/|X|$  and the total energy by  $-\lambda/2$ . Only certain *proper* values of  $\lambda$  are allowed, for we require that (1) have a non-zero solution  $\psi(X)$  in  $L_2(\mathbf{R}^3)$  with **grad**  $\psi(X)$  also in  $L_2(\mathbf{R}^3)$ , and it is well known that this can only happen for

$$(2) \quad \lambda = \frac{1}{n^2} \quad \text{with } n = 1, 2, 3, \dots$$

This result is deduced in most of the older books on elementary quantum mechanics; see for instance [1], pp. 80–86 or [2], pp. 347–352. The values of  $\lambda$  given by (2) correspond to the *energy levels* of the *bound states* of hydrogen; their differences figure as the *frequencies of spectrum lines* (in the spectrum of atomic hydrogen), and they are indeed very close to the actual observed frequencies.

In order to explain the spectra of alkali metals like sodium, Bohr and Sommerfeld proposed, 80 years ago, a model like the one for hydrogen, based partly on notions coming from chemistry. In that model one *outer* electron

moves *around*, and partly *through*, a small spherically symmetric *charge cloud* of *finite extent*, composed of the atom's *other* electrons and surrounding the nucleus. That charge cloud is supposed to *shield*, to a large extent, the outer electron from the attraction of the nucleus when these two are far apart, but to provide *less* shielding when the outer electron penetrates the cloud; the latter is otherwise taken as static. Such a picture can obviously represent only a first approximation; it has nevertheless been used since about 1920 in attempts to obtain, for the bound states of the alkali metals, a theoretical description of the energy levels that would agree with the results of spectroscopic measurement.

For any charge cloud model the potential energy must have the form

$$-\frac{1}{|X|} - \frac{\phi(|X|)}{2|X|}$$

with some positive function  $\phi(|X|)$  of *compact support* depending only on the radius, and which we may just as well take as *continuous*. In these circumstances the Schrödinger equation becomes

$$(3) \quad \nabla_X^2 \psi(X) + \left( \frac{2}{|X|} + \frac{\phi(|X|)}{|X|} - \lambda \right) \psi(X) = 0,$$

and one is interested in the proper values  $\lambda$  corresponding to non-zero solutions  $\psi$  with  $\psi(X)$  and  $\mathbf{grad} \psi(X)$  in  $L_2(\mathbf{R}^3)$ .

If the model is to embody a reasonable approximation to physical reality, these proper values must correspond to the empirical formulas for *spectral terms* of the alkali metals, published by Rydberg in 1890. To agree with his results, the proper values of (3) would have to be given by an approximate formula resembling (2), viz.,

$$(4) \quad \lambda \cong \frac{1}{(n - \delta_l)^2}.$$

Here  $n$  takes (certain) positive integral values and  $l$ , *for the moment*, is just an ad hoc index to which we may, if we like, assign the values  $0, 1, 2, \dots$ . The quantities  $\delta_l$  are constant and the different proper values can be grouped into *series* according to the value of  $l$ . (In place of that index, spectroscopists have always used the subscripts  $s, p, d, f, g, \dots$ ; for most of their work only the first 4 or 5 values of  $l$  are needed.)

The formula (4) does not correspond exactly to spectral data. For that we would need

$$(5) \quad \lambda = \frac{1}{(n - \delta_l(n))^2}$$

with slowly varying functions  $\delta_l(n)$ . What Rydberg's results suggest is that  $\delta_l(n)$  becomes, for each  $l$ , more and more nearly constant as  $n$  increases and *apparently tends to a limit  $\delta_l$  as  $n \rightarrow \infty$* . For about the past 75 years,  $\delta_l$  has been called a *quantum defect*.

Since the time of Bohr and Sommerfeld, physicists have maintained that quantum theory should yield (4) when the charge cloud model is assumed. In their attempts to show this they first worked with the older quantum theory (based on phase integrals), and later on with (3). There the idea is to deduce (5) for the proper values  $\lambda$  of (3), with *functions  $\delta_l(n)$  having finite limits for  $n \rightarrow \infty$* .

Most books on atomic structure and quantum mechanics, especially the older ones, include some discussion of this matter, usually heuristic or based on certain approximations. I cannot recall any of these books ever mentioning that in 1928, *two years (!)* after Schrödinger's equation first became known, Hartree ([3]) published a *proof* of the result in question. As long as  $\phi(|X|)$  is of compact support and continuous, the proper values of (3) *are* given by (5), and for each of the functions  $\delta_l(n)$  appearing there,  $\lim_{n \rightarrow \infty} \delta_l(n)$  *does* exist.

It was only by chance that I found out about [3]. I came across a reference to it in a long article by Seaton ([4]) which I had in turn learned about from [5], a book by Gallagher that I had just happened to notice on a shelf in our library at McGill. Seaton describes what Hartree did in the introduction to his paper, and I was able from that (with considerable help from pp. 87–90 of [6]) to reconstruct what I thought was Hartree's original argument. Afterwards, I looked up [3] and saw that my own procedure, based on the direct examination of certain contour integrals, was more transparent than the one followed there.

Hartree's proof is based on his identification of two special solutions, having particular behaviour as  $\lambda \rightarrow 0$ , of the "radial" Schrödinger equation for hydrogen (see §2 below), and especially on a remarkable *relation*, discovered by him, involving those two solutions. The first of them is now familiar and described in most books on elementary quantum mechanics, but the second is still *recondite* except for specialists in atomic collision theory. Discussion of the two solutions in [3] consists essentially of a detailed scrutiny of their respective series developments. The formulas for these series, especially for the second one, are very cumbersome, and it is hard for any reader to grasp from Hartree's laborious computations *why* the above mentioned relation should hold. Although both solutions now figure routinely (along with their numerous variants) in books on collision theory, it remains as difficult as it was in Hartree's time to deduce his relation from the series for them.

In the present article the solutions in question are represented in terms of contour integrals and their properties obtained from that representation. Hartree's relation involving the two solutions follows quite easily in this approach, by simple comparison of two branches of the function  $((z - \kappa)/(z + \kappa))^{1/\kappa}$ . A small gap in the original version of the proof is remedied here by the inclusion of Theorem 4 at the end of §8. Formulas like the one of Ritz, expressing the dependence on  $n$  of the  $\delta_l(n)$  appearing in (5), are deduced in §12 from the contour integrals.

I am grateful to my friend V.P. Havin for several conversations about this material. His persistent questions about the sketch of Hartree's plan given in §2 led me, when I was already lecturing on this subject, to realize that the plan itself was incomplete and to work out what was needed to set it right.

I think finally that this article may be useful for non-specialists who wish to understand the mathematics underlying the first principles of quantum defect theory. There has been a renewal of interest in that subject, due partly to the generalization of laser technology in experimental work. For references the reader may consult [4], [5], [9] and [10]; [8] is a somewhat older work on general collision theory. The referee has called my attention to the more recent paper of M. A. Shubov [13]. I am beholden to A. Dalgarno for a photocopy of [10], an interesting historical survey of the subject.

1. The index  $l$  affixed to the functions  $\delta_l(n)$  appearing in (5) has, of course, a physical meaning; it represents the outer electron's angular momentum for the bound state under consideration. Let us, for the remainder of this paper, fix a definite spherical harmonic  $Q_l(\Omega)$  of degree  $l \geq 0$ , where  $\Omega$  denotes a point ranging over the unit sphere in  $\mathbf{R}^3$ . We then restrict our attention to the possible solutions  $\psi(X)$  of (3) associated with this particular  $Q_l$ ; if we write  $X = r\Omega$  with  $r = |X|$ , they take the form

$$\psi(r\Omega) = \frac{u(r)}{r} Q_l(\Omega),$$

where, as is well known (see [1], pp. 70–74 or [2], pp. 347–352),  $u(r)$  must satisfy the ordinary differential equation

$$(6) \quad \frac{d^2 u(r)}{dr^2} + \left( \frac{2}{r} + \frac{\phi(r)}{r} - \frac{l(l+1)}{r^2} - \lambda \right) u(r) = 0.$$

This is frequently referred to as the "radial" Schrödinger equation and  $u(r)$  as the *radial part* of  $\psi(X)$ ; for bound states our conditions on  $\psi$  require that  $u(r)$  and  $u'(r) - (u(r)/r)$  be in  $L_2(0, \infty)$ .

THEOREM 1. Equation (6) has a solution  $u(r, \lambda)$  in  $[0, \infty)$  with

$$(7) \quad u(r, \lambda) = r^{l+1} + O(r^{l+2})$$

for  $r$  near 0, and this solution is an entire function of the parameter  $\lambda$ .

*Proof.* We first fix some  $L > 0$  and show that (6) has a solution  $u(r, \lambda)$  satisfying (7) and analytic in  $\lambda$  for  $|\lambda| < L$ . It is enough to obtain such a solution in any interval  $[0, a]$  with  $a > 0$ , for then the former can be uniquely continued to  $[a, \infty)$  by the usual existence theorem for differential equations, and its analyticity in  $\lambda$  for  $|\lambda| < L$  will persist for  $r > a$  by a complement to that theorem (see, e.g., [6], pp. 6–7 or [11], pp. 62–73).

The procedure is a little different according as  $l \geq 1$  or  $l = 0$ , and we first consider the former case. Start then by putting  $u_0(r, \lambda) = r^{l+1}$  and taking

$$(8) \quad u_{n+1}(r, \lambda) = \int_0^r \int_0^s \left( \frac{l(l+1)}{t^2} - \frac{2 + \phi(t)}{t} + \lambda \right) u_n(t, \lambda) dt ds$$

for  $n = 0, 1, 2, \dots$ .

From (8) we first get  $u_1(r, \lambda) = r^{l+1} + O(r^{l+2})$  and then, writing  $u_n(r)$  for  $u_n(r, \lambda)$  to save space, the relation

$$(9) \quad u_{n+2}(r) - u_{n+1}(r) = \int_0^r \int_0^s \left( \frac{l(l+1)}{t^2} - \frac{2 + \phi(t)}{t} + \lambda \right) (u_{n+1}(t) - u_n(t)) dt ds.$$

It follows from this by mathematical induction that  $u_n(r) = r^{l+1} + O(r^{l+2})$  for all  $n$ , making

$$u_{n+1}(r) - u_n(r) = O(r^{l+2})$$

for  $n = 0, 1, 2, \dots$ . Supposing, then, that  $a > 0$  and that

$$(10) \quad |u_{n+1}(r) - u_n(r)| \leq M_n r^{l+2}$$

for  $0 \leq r \leq a$ , we find from (9) that

$$|u_{n+2}(r) - u_{n+1}(r)| \leq M_n \left\{ \frac{l}{l+2} + \frac{Ca}{(l+2)(l+3)} + \frac{La^2}{(l+3)(l+4)} \right\} r^{l+2}$$

when  $0 \leq r \leq a$  and  $|\lambda| < L$ , where  $C = \max\{|2 + \phi(t)|; 0 \leq t \leq a\}$ . We can thus fix  $a > 0$ , depending only on  $L$ , so as to make (10) imply

$$|u_{n+2}(r) - u_{n+1}(r)| \leq M_{n+1} r^{l+2}$$

for  $0 \leq r \leq a$  and  $|\lambda| < L$ , with

$$M_{n+1} = \frac{l}{l+1} M_n.$$

The sum

$$\sum_{n=0}^{\infty} (u_{n+1}(r, \lambda) - u_n(r, \lambda))$$

will therefore converge uniformly (like a geometric series) for  $0 \leq r \leq a$  and  $|\lambda| < L$ ; by (9) it must thus represent a function analytic in  $\lambda$  for such  $r$  and  $\lambda$ . Referring now to (8) and making  $n \rightarrow \infty$  therein, we see that the function

$$u(r, \lambda) = u_0(r, \lambda) + \sum_{n=0}^{\infty} (u_{n+1}(r, \lambda) - u_n(r, \lambda)),$$

defined for  $0 \leq r \leq a$  and  $|\lambda| < L$ , is a solution of (6) with the stipulated analyticity, satisfying (7).

When  $l = 0$  we start by taking  $u_0(r, \lambda) = r$  and then putting

$$(11) \quad u_{n+1}(r, \lambda) = r - \int_0^r \int_0^s \left( \frac{2 + \phi(t)}{t} - \lambda \right) u_n(t, \lambda) dt ds$$

for  $n = 0, 1, 2, \dots$ . It is readily checked by induction that  $u_{n+1}(r, \lambda) - u_n(r, \lambda)$  is  $O(r^{n+2})$  for each  $n$ , and then the estimation of  $|u_{n+2}(r, \lambda) - u_{n+1}(r, \lambda)|$  in terms of a bound for  $|u_{n+1} - u_n|$  can be carried out as above. The series  $\sum_{n=0}^{\infty} (u_{n+1}(r, \lambda) - u_n(r, \lambda))$  will actually converge quite rapidly and the desired result follows as before on letting  $n \rightarrow \infty$  in (11).

From (6) and the proof just completed it is manifest that, on any *bounded* interval of  $[0, \infty)$ ,  $u(r, \lambda)$  and its first two derivatives with respect to  $r$  depend, *analytically and in a uniform manner*, on the parameter  $\lambda$ . We have, in particular,

$$(12) \quad u(r, \lambda) = u(r, 0) + \sum_{m=1}^{\infty} u^{(m)}(r) \lambda^m$$

with certain smooth functions  $u^{(m)}(r)$ . Here,  $u(r, 0)$  is a solution of

$$(13) \quad \frac{d^2 u}{dr^2} + \left( \frac{2 + \phi(r)}{r} - \frac{l(l+1)}{r^2} \right) u = 0$$

satisfying (7) at the origin.

Our concern here is ultimately with the *values* of  $\lambda$  for which non-zero solutions  $u(r)$  of (6) meeting the requirements mentioned just before Theorem 1 are forthcoming. By those conditions  $u(r)$  and  $u'(r) - (u(r)/r)$  are,



in particular, obliged to be square integrable on small intervals  $(0, a)$ ,  $a > 0$ , and that is certainly true for the solutions  $u(r, \lambda)$  furnished by the theorem.

But (6) has *other* solutions in  $(0, \infty)$ . If  $u(r)$  is any one of those, a standard recipe yields

$$\frac{d}{dr} \left( \frac{u(r)}{u(r, \lambda)} \right) = \frac{\text{const}}{(u(r, \lambda))^2},$$

at least for *small*  $r > 0$  where the denominator on the right does not vanish by (7) – see [11], p. 122. From this we get

$$u(r) = Au(r, \lambda) + B(r^{-l} + o(r^{-l}))$$

near 0, with certain constants  $A$  and  $B$ . If  $l > 0$ , the right side is not in  $L_2(0, a)$  unless  $B = 0$ , and *even* when  $l = 0$ , substitution into (6) and subsequent integration show that  $u'(r) = Au'(r, \lambda) + O(\log r)$ . This *is* in  $L_2(0, a)$ , but *now*  $u(r)/r$  is *not*, unless  $B$  is *again* 0. It follows that *the only solutions of (6) of interest to us here are the constant multiples of  $u(r, \lambda)$ .*

2. We wish, then, to see for which values of  $\lambda$  the solution  $u(r, \lambda)$  to (6) furnished by Theorem 1 is in  $L_2(0, \infty)$ . Since this solution is obviously in  $L_2(0, a)$  for any  $a > 0$ , our question amounts to asking when  $u(r, \lambda)$  is in  $L_2(a, \infty)$  for some  $a > 0$ .

According to our assumptions on  $\phi(r)$ , *that function vanishes identically for all  $r \geq$  some  $r_0$ .* For such  $r$ ,  $u(r, \lambda)$  must therefore *coincide* with a solution  $v(r)$  of

$$(14) \quad \frac{d^2 v(r)}{dr^2} + \left( \frac{2}{r} - \frac{l(l+1)}{r^2} - \lambda \right) v(r) = 0,$$

equal, of course, to the *radial part* of some solution  $\psi(X)$  of (1) associated with our fixed spherical harmonic  $Q_l(\Omega)$ .

Being interested in *bound states*, we care only about the possible values of  $\lambda$  corresponding to *negative energy levels*  $-\lambda/2$ ; we may therefore put

$$(15) \quad \lambda = \kappa^2$$

with  $\kappa > 0$ . *This notation will be used from now on. We will also write*

$$(16) \quad \kappa = \frac{1}{\nu}$$

*whenever convenient; in the present article  $\kappa$  is usually small and  $\nu$  large.*

Hartree's fundamental observation in [3] was that for  $\lambda \geq 0$  (sic!), there are two linearly independent solutions  $v_1(r, \lambda)$  and  $v_2(r, \lambda)$  of (14), each *practically independent* of  $\lambda$  for small  $\lambda \geq 0$ , and such that, when  $\kappa > 0$ ,

$$(17) \quad v_1(r, \kappa^2) \cos \pi\nu + v_2(r, \kappa^2) \sin \pi\nu$$

decays exponentially as  $r \rightarrow \infty$ . Linear combinations of  $v_1$  and  $v_2$  not proportional to (17) have on the other hand exponential growth in  $r$  when  $\kappa > 0$ . Let us sketch now the reasoning leading from this result to the formula (4); a detailed argument will be given in §10.

For  $\lambda$  to be a proper value of (6) it is necessary and sufficient according to the above remark that  $u(r, \lambda)$  be in  $L_2(r_0, \infty)$  where, for  $r \geq r_0$ ,  $u(r, \lambda)$  also coincides with a linear combination of  $v_1(r, \kappa^2)$  and  $v_2(r, \kappa^2)$ . But it follows from Hartree's observation that such a linear combination is in  $L_2(r_0, \infty)$  if and only if it is proportional to (17). Therefore  $\lambda$  is a proper value of (6) if and only if

$$u(r, \lambda) = c (v_1(r, \kappa^2) \cos \pi\nu + v_2(r, \kappa^2) \sin \pi\nu)$$

with a constant  $c$  for  $r \geq r_0$ .

Now when  $\nu$  is very large and hence  $\lambda = \kappa^2$  close to 0, the last relation, by (12) and Hartree's observation, will be very close to

$$(18) \quad u(r, 0) = c (v_1(r, 0) \cos \pi\nu + v_2(r, 0) \sin \pi\nu), \quad r \geq r_0,$$

and we will similarly have (nearly)

$$(19) \quad u'(r, 0) = c (v_1'(r, 0) \cos \pi\nu + v_2'(r, 0) \sin \pi\nu), \quad r \geq r_0.$$

The uniqueness theorem for differential equations ([11], pp.62–83) and (7) imply that  $u(r_0, 0)$  and  $u'(r_0, 0)$  cannot both vanish; the quantity  $v_1(r_0, 0)v_2'(r_0, 0) - v_1'(r_0, 0)v_2(r_0, 0)$  cannot vanish either due to linear independence of  $v_1$  and  $v_2$ .

It follows that the relations obtained by putting  $r = r_0$  in (18) and (19) can usually be solved for  $\cot \pi\nu$  or, if not, for  $\tan \pi\nu$ . This will evidently determine the fractional part  $\Delta = \nu - [\nu]$  of  $\nu$  in a manner independent of  $\nu$  itself. The corresponding proper values  $\lambda = 1/\nu^2$  must therefore have the form  $1/([\nu] + \Delta)^2$ , with  $\Delta$  independent of  $[\nu]$ , for large  $\nu$ , and this is essentially (4).

Relations (18) and (19) are of course only approximations to the true ones and so therefore is the value  $\Delta$  for  $\nu - [\nu]$ , independent of  $\nu$ , obtained from them. However, when  $[\nu] \rightarrow \infty$ , that value should yield more and more nearly the exact values of  $\nu = [\nu] + (\nu - [\nu])$  associated with the proper values of (6).

In this way, Hartree arrived at Rydberg's empirical result. We see that his argument relies critically on the existence of the functions  $v_1(r, \kappa^2)$ ,  $v_2(r, \kappa^2)$  having precisely the properties described above; let us therefore proceed to the construction of such functions.

3. Equation (14) has a regular singular point at the origin and may thus be treated using the method of Frobenius (for which see, e.g., [2], pp. 61–78 or [11], pp. 160–164). The corresponding indicial equation has the roots  $-l$  and  $l+1$ , differing by an integer, which causes problems. Wishing to obtain *two* independent solutions to (14), we put

$$(20) \quad v(r) = r^{-l}w(r)$$

therein (and *not*  $v(r) = r^{l+1}w(r)$ , as is done in elementary books on quantum mechanics). Since  $\lambda = \kappa^2$ , that gives us

$$(21) \quad r \frac{d^2w(r)}{dr^2} - 2l \frac{dw(r)}{dr} + (2 - \kappa^2 r)w(r) = 0.$$

Direct substitution of a power series in  $r$  into (21) will only give us *one* solution (see above), so we instead resort to Laplace transforms as Schrödinger did in his first paper on the wave equation. This leads to a *first order* differential equation for the Laplace transform of  $w$ . To *find* that equation, we may as well *assume*  $w(r)$  to be given as an *inverse* Laplace transform, recalling that such objects can frequently be expressed in the form

$$(22) \quad w(r) = \int_C e^{rz} g(z) dz$$

with some “suitable” contour  $C$  and a function  $g(z)$ , single valued on  $C$  and analytic near each of its points (see [6], pp. 87–88).

When  $C$  is a *closed* curve, partial integration yields

$$\int_C r e^{rz} g(z) dz = - \int_C e^{rz} g'(z) dz$$

and

$$\int_C r e^{rz} z^2 g(z) dz = - \int_C e^{rz} \frac{d}{dz} (z^2 g(z)) dz.$$

Use of these formulas and differentiation under the integral sign in (22) show the right side of (21) to be equal to

$$\int_C \{(\kappa^2 - z^2)g'(z) + 2(1 - (l+1)z)g(z)\} e^{rz} dz,$$

which vanishes identically provided that

$$(\kappa^2 - z^2)g'(z) + 2(1 - (l+1)z)g(z) = 0.$$

For this we have a solution

$$(23) \quad g(z) = \frac{1}{(z - \kappa)^{l+1-\nu}(z + \kappa)^{l+1+\nu}}$$

(with, as always,  $\nu = 1/\kappa$ ), corresponding, by (22), to the solution

$$(24) \quad w(r) = \int_{\mathcal{C}} \left( \frac{z - \kappa}{z + \kappa} \right)^{1/\kappa} \frac{e^{rz}}{(z^2 - \kappa^2)^{l+1}} dz$$

of (21), subject to the above conditions on the behaviour of  $g(z)$  near  $\mathcal{C}$ .

Even with some curves  $\mathcal{C}$  that are *not closed*, (24) will give solutions of (21). For that it is of course necessary that the right side of (22) be (suitably) convergent and admit differentiation under the integral sign, and that  $g(z)$  be analytic at the points of  $\mathcal{C}$ . It is also essential to have the above partial integration formulas, but *they will hold* provided that  $e^{rz}g(z)$  and  $z^2 e^{rz}g(z)$  both tend to zero when  $z$  moves along  $\mathcal{C}$  towards *either end* of that curve.

4. Our procedure will be to look at the solutions  $w(r)$  of (21) obtained by using different contours  $\mathcal{C}$  in (24) and different branches of the (usually) many-valued function  $((z - \kappa)/(z + \kappa))^{1/\kappa}$ . The idea of doing this comes from pp. 87–88 of [6], and expressions like the integral in (24) are often referred to as Whittaker functions.

For our first choice, we take the *branch of  $((z - \kappa)/(z + \kappa))^{1/\kappa}$  which is analytic and single-valued outside the slit  $[-\kappa, \kappa]$  and positive for  $z = x > \kappa$* . This branch is analytic even at  $\infty$ , where it takes the value 1. For  $\mathcal{C}$  we take *any circle of radius  $A > \kappa$  about the origin, oriented in the counter-clockwise sense, and then put*

$$(25) \quad w_1(r, \kappa^2) = \frac{1}{i} \int_{\mathcal{C}} \left( \frac{z - \kappa}{z + \kappa} \right)^{1/\kappa} \frac{e^{rz}}{(z^2 - \kappa^2)^{l+1}} dz,$$

frequently writing  $w_1(r)$  for  $w_1(r, \kappa^2)$ .

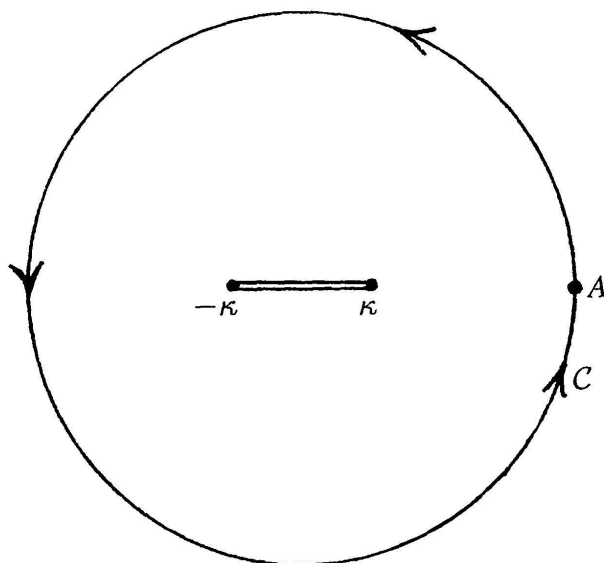

FIGURE 1

It will soon be apparent that  $w_1(r)$  really does depend on  $\kappa^2$  (and in an analytic manner) rather than just on  $\kappa$ . According to Cauchy's theorem, the integral in (25) is actually independent of the radius of  $\mathcal{C}$ , as long as it is  $> \kappa$ .

The discussion in §3 shows that  $w_1(r)$  is a solution of (21), and it will be very important for us later on that  $w_1(r)$  is real. That is so because our branch of  $((z - \kappa)/(z + \kappa))^{1/\kappa}$ , being real for  $z = x > \kappa$ , must take complex conjugate values at complex conjugate points  $z$  by the Schwarz reflection principle. The same is of course true for  $e^{rz}/(z^2 - \kappa^2)^{l+1}$  (here  $r$  is always  $\geq 0$ ), so the reality of  $w_1(r, \kappa^2)$  becomes manifest on putting  $z = Ae^{i\vartheta}$  in (25) and writing the integral appearing there as one with  $\vartheta$  ranging from  $-\pi$  to  $\pi$ .

By expanding  $e^{rz}$  in powers of  $rz$  we get, from (25),

$$(26) \quad w_1(r) = \sum_{m=0}^{\infty} a_m r^m$$

with

$$(27) \quad a_m = \frac{1}{m! i} \int_{\mathcal{C}} \left(\frac{z - \kappa}{z + \kappa}\right)^{1/\kappa} \frac{z^m}{(z^2 - \kappa^2)^{l+1}} dz.$$

Here, we can make the radius of  $\mathcal{C}$  tend to  $\infty$ , and we find in that way that  $a_m = 0$  for  $m = 0, 1, \dots, 2l$ , whereas  $a_{2l+1} = 2\pi/(2l + 1)!$  Thus,

$$(28) \quad w_1(r, \kappa^2) = \frac{2\pi}{(2l + 1)!} r^{2l+1} + \text{higher degree terms}.$$

On referring to (20), we see that

$$(29) \quad v_1(r, \kappa^2) = r^{-l} w_1(r, \kappa^2)$$

is a power-series solution of (14) (for  $\lambda = \kappa^2$ ), starting with a term in  $r^{l+1}$ . Aside from a constant factor, it therefore coincides with the usual solution of (14) obtained in elementary books on quantum mechanics (see, e.g., [1], pp. 80–86 or [2], pp. 347–352).

We shall need an expression of  $w_1(r, \kappa^2)$  as an integral over a contour different from  $\mathcal{C}$  (figure 1). Letting  $\kappa' > \kappa$  and taking the radius  $A$  of  $\mathcal{C}$  strictly between  $\kappa$  and  $\kappa'$ , Cauchy's theorem yields

$$(30) \quad \int_{\mathcal{C}} \left(\frac{z - \kappa}{z + \kappa}\right)^{1/\kappa} \frac{e^{rz}}{(z^2 - \kappa^2)^{l+1}} dz = \int_{\mathcal{C}'} \left(\frac{z - \kappa}{z + \kappa}\right)^{1/\kappa} \frac{e^{rz}}{(z^2 - \kappa^2)^{l+1}} dz,$$

where  $\mathcal{C}'$  is the contour shown in figure 2. The integrand on the right is  $O(|z|^{-2l-2})$  on the semi-circular part of  $\mathcal{C}'$  when the radius  $B$  of the latter

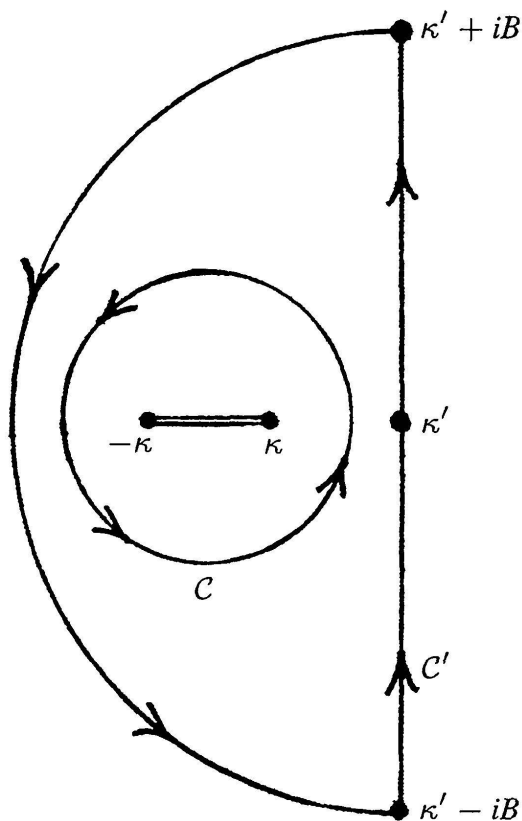

FIGURE 2

is large, so the integral along that part tends to zero as  $B \rightarrow \infty$  ( $r$  is always  $\geq 0$ ). From (25) we thus have

$$(31) \quad w_1(r, \kappa^2) = \frac{1}{i} \int_{\kappa' - i\infty}^{\kappa' + i\infty} \left( \frac{z - \kappa}{z + \kappa} \right)^{1/\kappa} \frac{e^{rz}}{(z^2 - \kappa^2)^{l+1}} dz;$$

here  $\kappa' > \kappa$  can be taken as close as we like to  $\kappa$ .

It remains to see how  $w_1(r, \kappa^2)$  depends on  $\kappa$  when  $\kappa \rightarrow 0$ . For this purpose we fix the circle  $C$  used in (25) and note that, on that circle, we have uniformly

$$\log \left( \frac{z - \kappa}{z + \kappa} \right) = -\frac{2\kappa}{z} - \frac{2\kappa^3}{3z^3} - \frac{2\kappa^5}{5z^5} - \dots$$

for small  $\kappa > 0$  and the branch of the left-hand logarithm which is zero at  $\infty$ . Thence,

$$\begin{aligned} \left( \frac{z - \kappa}{z + \kappa} \right)^{1/\kappa} &= \exp \left\{ \frac{1}{\kappa} \left( -\frac{2\kappa}{z} - \frac{2\kappa^3}{3z^3} - \frac{2\kappa^5}{5z^5} - \dots \right) \right\} \\ &= e^{-2/z} \exp \left\{ -\frac{2\kappa^2}{3z^3} - \frac{2\kappa^4}{5z^5} - \frac{2\kappa^6}{7z^7} - \dots \right\} \end{aligned}$$

uniformly on  $\mathcal{C}$  (for the branch of  $((z - \kappa)/(z + \kappa))^{1/\kappa}$  in use here). At the same time,

$$\frac{1}{(z^2 - \kappa^2)^{l+1}} = \frac{1}{z^{2l+2}} \left(1 - \frac{\kappa^2}{z^2}\right)^{-2l-2}.$$

Substitution of these formulas into (25) shows (by inspection!) that  $w_1(r, \kappa^2)$  is an analytic function of  $\kappa^2$  when  $\kappa$  is near 0, and varies uniformly with  $\kappa^2$  when  $r \geq 0$  is bounded. On differentiating both sides of (25) with respect to  $r$ , we see that an analogous statement holds for  $w_1'(r, \kappa^2)$ .

From the preceding formulas we see also that  $w_1(r, \kappa^2) \rightarrow w_1(r, 0)$  uniformly for bounded  $r$  as  $\kappa \rightarrow 0$ , where

$$(32) \quad w_1(r, 0) = \frac{1}{i} \int_{\mathcal{C}} \frac{e^{-2/z} e^{rz}}{z^{2l+2}} dz,$$

and that  $w_1'(r, \kappa^2)$  behaves in corresponding fashion. The function  $w_1(r, 0)$  is simply a solution of (21) for  $\kappa = 0$ , and for it the expansion (28) is still valid. The reader may recognize that the integral in (32) can be expressed in terms of a Bessel function.

Most of the last conclusions could also have been deduced from the results in §1. On taking  $\phi(r) \equiv 0$  in (6) we obtain (14), and the solution  $u(r, \lambda)$  of the former goes over to  $((2l + 1)!/2\pi)v_1(r, \kappa^2)$ , with  $v_1(r, \kappa^2)$  related to  $w_1(r, \kappa^2)$  by (29).

5. We pass to the construction of a second solution,  $w_3(r, \kappa^2)$ , to (21) – before defining  $w_2(r, \kappa^2)$ ! – and for this we need a *different branch* of  $((z - \kappa)/(z + \kappa))^{1/\kappa}$ . The *present one* agrees with the branch used in the last § when  $\text{Re } z > \kappa$ , but it is then extended by analytic continuation from that half-plane into the whole simply-connected domain obtained by *removing the two rays*  $(-\infty, -\kappa]$ ,  $[\kappa, \kappa + i\infty)$  from  $\mathbf{C}$  (see figure 3).

Taking a contour  $\mathcal{C}''$  of the form shown in figure 3 (cf. [6], p. 88) we put, using this *new branch*,

$$(33) \quad w_3(r, \kappa^2) = \frac{1}{i} \int_{\mathcal{C}''} \left(\frac{z - \kappa}{z + \kappa}\right)^{1/\kappa} \frac{e^{rz}}{(z^2 - \kappa^2)^{l+1}} dz$$

for  $r \geq 0$ , and shall often denote  $w_3(r, \kappa^2)$  by  $w_3(r)$ .

The integrand in (33) is  $O(|z|^{-2l-2})$  for  $\text{Re } z \leq 0$  and  $z \rightarrow \infty$ , so we may use Cauchy's theorem as in the last § to conclude that *the integral does not depend on the exact position* of the horizontal portions of  $\mathcal{C}''$ , nor on the radius of that contour's circular part (as long as it is  $< 2\kappa$ ); the horizontal portions may even be taken to run along the *upper and lower edges of the*

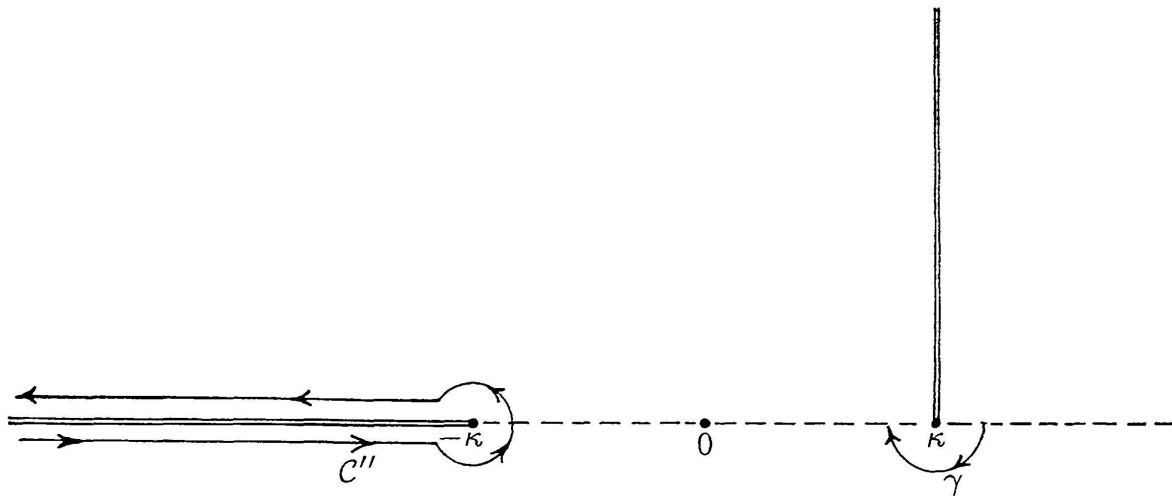

FIGURE 3

slit  $(-\infty, -\kappa]$ . Making the radius of the circular part of  $C''$  equal to a small quantity  $\varepsilon > 0$ , we see from (33) that  $w_3(r, \kappa^2)$  decays at least as rapidly as  $e^{-(\kappa-\varepsilon)r}$  when  $r \rightarrow \infty$ ;  $\varepsilon$  can, of course, be taken as close to 0 as we like.

The function  $w_3(r, \kappa^2)$  is obviously continuous in  $r$  for  $r \geq 0$ . Moreover, when  $r > 0$ , the contour  $C''$  and the function  $g(z)$  given by (23) fulfill the conditions noted at the end of §3;  $w_3(r, \kappa^2)$  therefore satisfies (21) for  $r > 0$ .

Another integral representation of  $w_3(r)$  will be essential in our work. Fix  $\kappa''$ ,  $-\kappa < \kappa'' < \kappa$ , and take the contour  $\Gamma''$  shown in figure 4. By Cauchy's theorem,

$$(34) \quad \int_{\Gamma''} \left( \frac{z - \kappa}{z + \kappa} \right)^{1/\kappa} \frac{e^{rz}}{(z^2 - \kappa^2)^{l+1}} dz = 0.$$

When the radius  $B$  of the two large (near) quarter circles is very big, the contributions to (34) corresponding to them become negligible (for  $r \geq 0$ ), and we get, by (33),

$$(35) \quad w_3(r, \kappa^2) = \frac{1}{i} \int_{\kappa'' - i\infty}^{\kappa'' + i\infty} \left( \frac{z - \kappa}{z + \kappa} \right)^{1/\kappa} \frac{e^{rz}}{(z^2 - \kappa^2)^{l+1}} dz.$$

This relation is used, in the first place, to show that  $e^{\pi i \nu} w_3(r, \kappa^2)$  is real (recall that  $\nu = 1/\kappa$ ). To see this, look at the little semi-circle  $\gamma$  in figure 3, keeping in mind that our present branch of  $((z - \kappa)/(z + \kappa))^{1/\kappa}$  is taken as positive for  $z = x > \kappa$ . It is then clear that for  $-\kappa < x < \kappa$ ,  $((x - \kappa)/(x + \kappa))^{1/\kappa} = e^{-\pi i/\kappa} ((\kappa - x)/(\kappa + x))^{1/\kappa}$ , with  $((\kappa - x)/(\kappa + x))^{1/\kappa}$  taken as positive on that range. Letting  $\kappa'' = 0$  in (35), we thus obtain



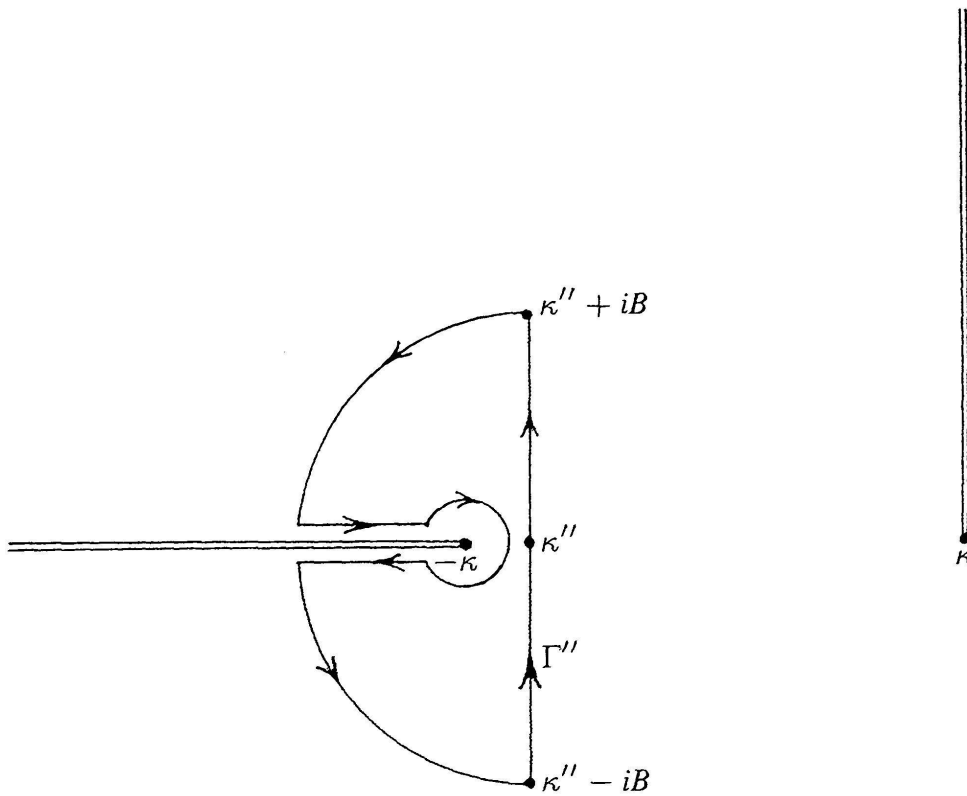

FIGURE 4

$$w_3(r, \kappa^2) = (-1)^{l+1} e^{-\pi i \nu} \int_{-\infty}^{\infty} \left( \frac{\kappa - iy}{\kappa + iy} \right)^{1/\kappa} \frac{e^{iy}}{(y^2 + \kappa^2)^{l+1}} dy,$$

with  $((\kappa - iy)/(\kappa + iy))^{1/\kappa}$  assuming *complex conjugate values* at  $y = \pm|y|$ , due to Schwarz reflection of  $((\kappa - z)/(\kappa + z))^{1/\kappa}$  across the interval  $(-\kappa, \kappa)$ . *Reality* of the integral on the right (standing by itself) is thus manifest, and the above statement proved.

In the next §, we shall use (35) with  $\kappa''$  tending to  $\kappa$  from below.

6. The second solution of (21) which is really of interest to us will be obtained from the difference  $w_1(r, \kappa^2) - w_3(r, \kappa^2)$ . From (31) and (35) we have

$$w_1(r, \kappa^2) - w_3(r, \kappa^2) = \frac{1}{i} \left( \int_{\kappa' - i\infty}^{\kappa' + i\infty} - \int_{\kappa'' - i\infty}^{\kappa'' + i\infty} \right) \left( \frac{z - \kappa}{z + \kappa} \right)^{1/\kappa} \frac{e^{rz}}{(z^2 - \kappa^2)^{l+1}} dz$$

where  $-\kappa < \kappa'' < \kappa < \kappa'$ ,  $\kappa'$  and  $\kappa''$  being otherwise arbitrary. In *both* of the integrations on the right, we may use the branch of  $((z - \kappa)/(z + \kappa))^{1/\kappa}$  specified in §5, since it agrees for  $\text{Re } z > \kappa$  with the one employed in §4 and in (31).

In all of the work of this paper we are concerned with *large* values of  $\nu = 1/\kappa$ ; there is therefore *no loss of generality in our assuming*, whenever necessary, *that*  $\nu = 1/\kappa > l+1$ , *and we henceforth do so*. In this circumstance, we see from figure 3 that the difference

$$\left( \int_{\kappa'-i\infty}^{\kappa'} - \int_{\kappa''-i\infty}^{\kappa''} \right) \left( \frac{z-\kappa}{z+\kappa} \right)^{1/\kappa} \frac{e^{rz}}{(z^2-\kappa^2)^{l+1}} dz$$

will tend to zero when  $\kappa'' \uparrow \kappa$  and  $\kappa' \downarrow \kappa$ . Passing to that limit in the preceding relation, we thus get

$$(36) \quad w_1(r, \kappa^2) - w_3(r, \kappa^2)$$

$$= \frac{1}{i} \int_{\kappa}^{\kappa+i\infty} \left\{ \left( \frac{z_+ - \kappa}{z_+ + \kappa} \right)^{1/\kappa} - \left( \frac{z_- - \kappa}{z_- + \kappa} \right)^{1/\kappa} \right\} \frac{e^{rz}}{(z^2 - \kappa^2)^{l+1}} dz.$$

In this formula,  $z_+$  is understood to lie *on the right edge of the branch cut*  $[\kappa, \kappa + i\infty)$  and  $z_-$  *on its left edge*; we need to work out the difference in curly brackets standing on the right. But that difference can be read off from figure 5; it is

$$(1 - e^{-2\pi i/\kappa}) \left( \frac{z_+ - \kappa}{z_+ + \kappa} \right)^{1/\kappa}.$$

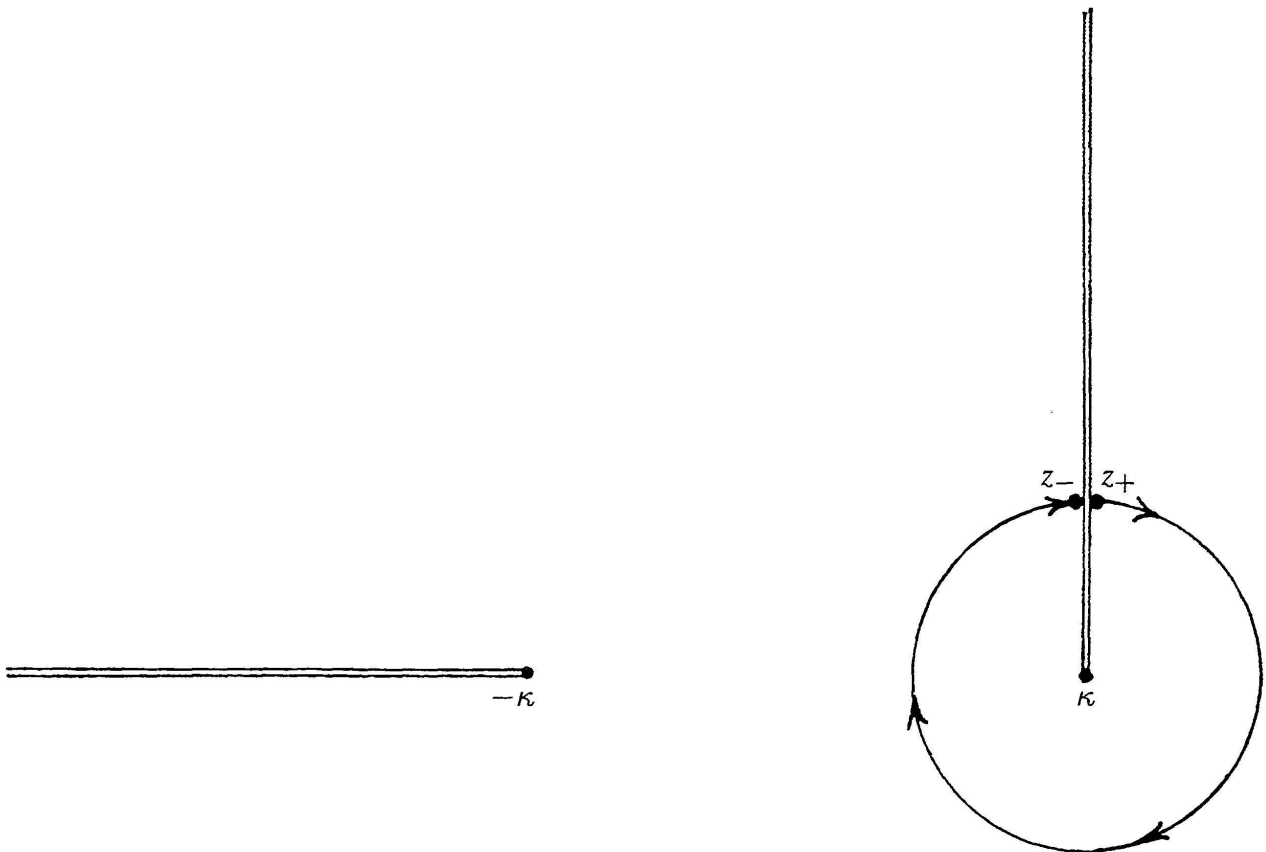

FIGURE 5

Here the quantity  $((z_+ - \kappa)/(z_+ + \kappa))^{1/\kappa}$  is nothing but  $((z - \kappa)/(z + \kappa))^{1/\kappa}$  determined by the branch used in §4. Therefore (36) becomes

$$(37) \quad w_1(r) - w_3(r) = \frac{1 - e^{-2\pi i \nu}}{i} \int_{\kappa}^{\kappa+i\infty} \left(\frac{z - \kappa}{z + \kappa}\right)^{1/\kappa} \frac{e^{rz}}{(z^2 - \kappa^2)^{l+1}} dz,$$

with the branch from §4 understood on the right.

We now recall that  $w_1(r, \kappa^2)$  is real (§4) and that  $e^{\pi i \nu} w_3(r, \kappa^2)$  is also real (§5); for these reasons we multiply (37) through by  $e^{\pi i \nu}$  and transpose, getting

$$e^{\pi i \nu} w_1(r) - 2 \sin \pi \nu \int_{\kappa}^{\kappa+i\infty} \left(\frac{z - \kappa}{z + \kappa}\right)^{1/\kappa} \frac{e^{rz}}{(z^2 - \kappa^2)^{l+1}} dz = e^{\pi i \nu} w_3(r).$$

Taking real parts, we find that

$$(38) \quad w_1(r) \cos \pi \nu - 2 \sin \pi \nu \operatorname{Re} \int_{\kappa}^{\kappa+i\infty} \left(\frac{z - \kappa}{z + \kappa}\right)^{1/\kappa} \frac{e^{rz}}{(z^2 - \kappa^2)^{l+1}} dz = e^{\pi i \nu} w_3(r),$$

where, as seen in §5, the right side decays exponentially when  $r \rightarrow \infty$ .

Understanding always the branch of  $((z - \kappa)/(z + \kappa))^{1/\kappa}$  from §4, we now put

$$(39) \quad w_2(r, \kappa^2) = -2 \operatorname{Re} \int_{\kappa}^{\kappa+i\infty} \left(\frac{z - \kappa}{z + \kappa}\right)^{1/\kappa} \frac{e^{rz}}{(z^2 - \kappa^2)^{l+1}} dz$$

for  $1/\kappa > l + 1$  and  $r \geq 0$ . This function is clearly continuous for  $r \geq 0$  and we claim that it is a solution of (21) in  $(0, \infty)$ .

Since  $w_1(r)$  and  $w_3(r)$  are both solutions of (21), that follows from (38) except when  $\nu$  is an integer. That case must be handled by direct examination of the integral in (39). Unfortunately, the conditions noted at the end of §3 are not fulfilled for that integral when  $l = 0$ . But we do have

$$\int_{\kappa}^{\kappa+i\infty} \left(\frac{z - \kappa}{z + \kappa}\right)^{1/\kappa} \frac{e^{rz}}{(z^2 - \kappa^2)^{l+1}} dz = \int_{\mathcal{L}} \left(\frac{z - \kappa}{z + \kappa}\right)^{1/\kappa} \frac{e^{rz}}{(z^2 - \kappa^2)^{l+1}} dz$$

with the path  $\mathcal{L}$  shown in figure 6, as long as  $r \geq 0$  and  $1/\kappa > l + 1$ . Indeed, since we are using the branch of  $((z - \kappa)/(z + \kappa))^{1/\kappa}$  from §4 in the integral on the left, the relation follows by the usual application of Cauchy's theorem (with that same branch on the right). This being the case, it is enough to check the conditions from §3 for the integral along  $\mathcal{L}$ , and they are found to hold when  $r > 0$ .

We have arrived at essentially the basic relation used by Hartree. Putting together (38), (39) and the above observations we obtain

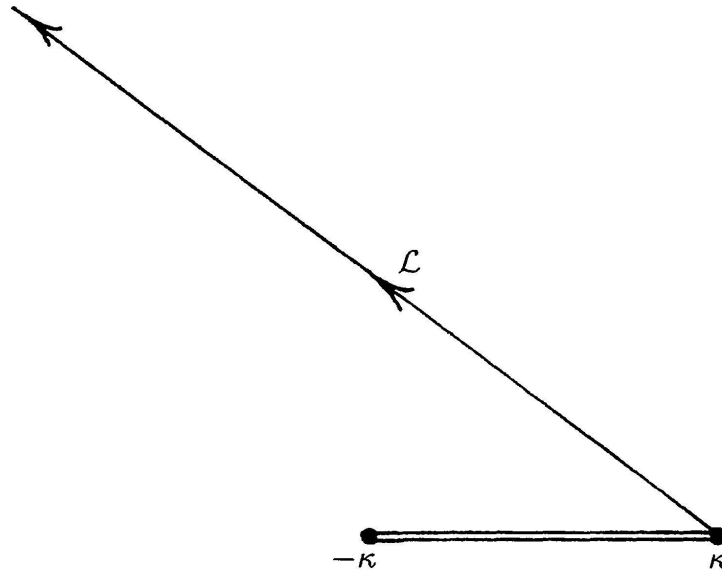

FIGURE 6

THEOREM 2. For  $l + 1 < 1/\kappa < \infty$  equation (21) has, in  $(0, \infty)$ , two solutions,  $w_1(r, \kappa^2)$  and  $w_2(r, \kappa^2)$ , given by (25) and (39) respectively, both continuous down to the origin. For each such  $\kappa$ , the sum

$$w_1(r, \kappa^2) \cos \pi\nu + w_2(r, \kappa^2) \sin \pi\nu$$

decays exponentially as  $r \rightarrow \infty$ .

7. The behaviour of  $w_1(r, \kappa^2)$  for  $\kappa \rightarrow 0$  was discussed towards the end of §4, and now we have to take up that of  $w_2(r, \kappa^2)$ . For this it is best to replace the straight path of integration  $[\kappa, \kappa + i\infty)$  used in (39) by the contour  $\Gamma_\kappa$  shown in figure 7. That replacement is justified by the usual appeal to Cauchy's theorem, and we have

$$(40) \quad w_2(r, \kappa^2) = -2 \operatorname{Re} \omega(r, \kappa^2),$$

where

$$(41) \quad \omega(r, \kappa^2) = \int_{\Gamma_\kappa} \left( \frac{z - \kappa}{z + \kappa} \right)^{1/\kappa} \frac{e^{rz}}{(z^2 - \kappa^2)^{l+1}} dz.$$

As in (39), the branch of  $((z - \kappa)/(z + \kappa))^{1/\kappa}$  from §4 is to be used in this integral.

It is convenient to look on  $\Gamma_\kappa$  as consisting of the segment  $[\kappa, 1]$  followed by  $\Gamma$ , the upper part of  $\Gamma_\kappa$ , because the latter does not depend on the parameter  $\kappa$  (see figure 7). We can thus rewrite (41) as

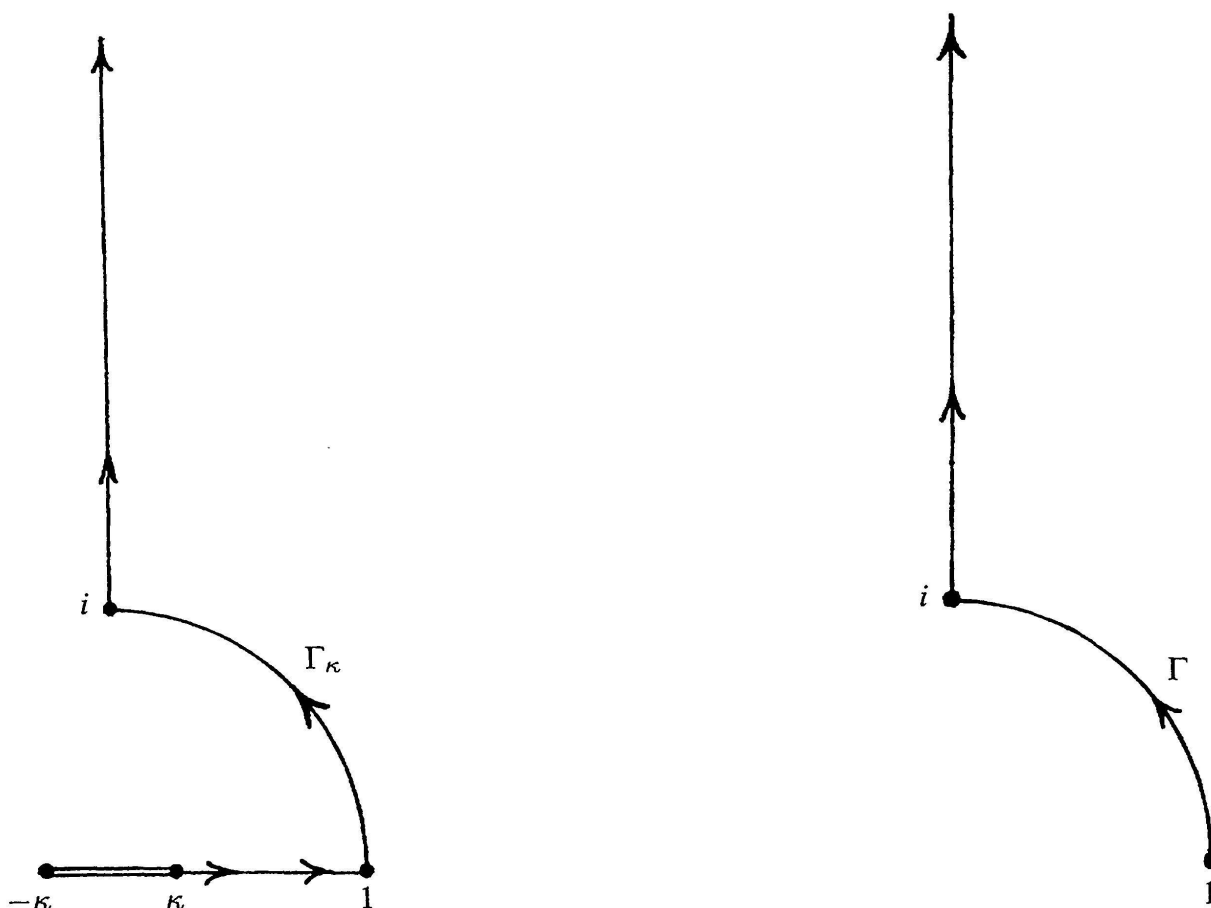

FIGURE 7

$$(42) \quad \omega(r, \kappa^2) = \int_{\kappa}^1 \left( \frac{x - \kappa}{x + \kappa} \right)^{1/\kappa} \frac{e^{rx}}{(x^2 - \kappa^2)^{l+1}} dx + \int_{\Gamma} \left( \frac{z - \kappa}{z + \kappa} \right)^{1/\kappa} \frac{e^{rz}}{(z^2 - \kappa^2)^{l+1}} dz,$$

and we proceed to look separately at the two integrals standing on the right.

Concerning the *second* one we note, as in §4, that

$$\left( \frac{z - \kappa}{z + \kappa} \right)^{1/\kappa} = e^{-2/z} \exp\left( -\frac{2\kappa^2}{3z^3} - \frac{2\kappa^4}{5z^5} - \frac{2\kappa^6}{7z^7} - \dots \right),$$

this in fact holds uniformly on  $\Gamma$  as long as  $0 < \kappa^2 < 1$ . For  $z$  on  $\Gamma$  we also have

$$\begin{aligned} \frac{1}{(z^2 - \kappa^2)^{l+1}} &= \frac{1}{z^{2l+2}} \exp\left\{ -(l+1) \log\left(1 - \frac{\kappa^2}{z^2}\right) \right\} \\ &= \frac{1}{z^{2l+2}} \exp\left( \frac{(l+1)\kappa^2}{z^2} + \frac{(l+1)\kappa^4}{2z^4} + \frac{(l+1)\kappa^6}{3z^6} + \dots \right), \end{aligned}$$

and the power series in ( ) converges uniformly on  $\Gamma$  as long as  $0 < \kappa^2 < 1$ .

From these results we get

$$(43) \quad \left(\frac{z-\kappa}{z+\kappa}\right)^{1/\kappa} \cdot \frac{1}{(z^2-\kappa^2)^{l+1}} = \frac{e^{-2/z}}{z^{2l+2}} \left(1 + \theta(z) + \frac{(\theta(z))^2}{2!} + \frac{(\theta(z))^3}{3!} + \dots\right)$$

for  $z$  on  $\Gamma$ , where

$$(44) \quad \theta(z) = \kappa^2 \left(\frac{l+1}{z^2} - \frac{2}{3z^3}\right) + \kappa^4 \left(\frac{l+1}{2z^4} - \frac{2}{5z^5}\right) + \kappa^6 \left(\frac{l+1}{3z^6} - \frac{2}{7z^7}\right) + \dots$$

The second right-hand integral in (42) is thus equal to

$$(45) \quad \int_{\Gamma} \frac{e^{-2/z} e^{rz}}{z^{2l+2}} \left(1 + \theta(z) + \frac{(\theta(z))^2}{2!} + \frac{(\theta(z))^3}{3!} + \dots\right) dz.$$

It is clear from (44) that this expression is *analytic in  $\kappa^2$  for  $|\kappa^2| < 1$*  (sic!), and tends to

$$(46) \quad \int_{\Gamma} \frac{e^{-2/z} e^{rz}}{z^{2l+2}} dz$$

as  $\kappa \rightarrow 0$ ; the convergence is obviously *uniform in  $r$  on any bounded interval  $0 \leq r \leq a$* .

The *first* right-hand integral in (42) is examined with the help of a technique to be used again later on. When  $\nu = 1/\kappa > l+1$ , that integral can be rewritten as

$$\int_{\kappa}^1 \left(1 - \frac{2\kappa}{x+\kappa}\right)^{\nu-l-1} \frac{e^{rx}}{(x+\kappa)^{2l+2}} dx,$$

and on putting  $\xi = 1/(x+\kappa)$ , this goes over to

$$(47) \quad e^{-\kappa r} \int_{1/(1+\kappa)}^{1/2\kappa} \left(1 - \frac{2\xi}{\nu}\right)^{\nu-l-1} \xi^{2l} e^{r/\xi} d\xi.$$

Here we recall that for fixed  $\xi > 0$  the expression  $\left(1 - \frac{2\xi}{\nu}\right)^{\nu}$  *increases with  $\nu$  for  $\nu \geq 2\xi$  and is therefore  $\leq e^{-2\xi}$* ; that is thus the case for the  $\xi$  appearing in the integral (47). Since  $\nu - l - 1 = \nu \left(1 - \frac{l+1}{\nu}\right)$ , we see from this that (47) tends by dominated convergence to

$$(48) \quad \int_1^{\infty} e^{-2\xi} \xi^{2l} e^{r/\xi} d\xi = \int_0^1 \frac{e^{-2/x} e^{rx}}{x^{2l+2}} dx$$

as  $\kappa \rightarrow 0$ , and that *the convergence is uniform for  $r$  restricted to any bounded interval of  $[0, \infty)$* .

Putting these results together we see from (42), (46) and (48) that, *when  $\kappa \rightarrow 0$ ,*

$$(49) \quad \omega(r, \kappa^2) \longrightarrow \int_{\Gamma_0} \frac{e^{-2/z} e^{rz}}{z^{2l+2}} dz$$

uniformly on any bounded interval in  $[0, \infty)$ ; here  $\Gamma_0$  is  $\Gamma_\kappa$  for  $\kappa = 0$ , i.e.,  $(0, 1]$  followed by the contour  $\Gamma$  (figure 7).

Denoting the right-hand member in (49) by  $\omega(r, 0)$ , let us first compute  $\omega(0, 0)$ . When  $r = 0$ , the contour  $\Gamma_0$  in (49) can be replaced by  $(0, \infty)$  (again by Cauchy's theorem), so we get

$$(50) \quad \omega(0, 0) = \int_0^\infty \frac{e^{-2/x}}{x^{2l+2}} dx = \frac{(2l)!}{2^{2l+1}}.$$

Let us next check that the function  $w(r) = \omega(r, 0)$  satisfies (21) with  $\kappa = 0$  for  $r > 0$ . Here we run up against the same difficulty as at the end of §6 when  $l = 0$ , and we get around it in similar fashion as we did there, replacing  $\Gamma_0$  in (49) by the contour  $\Gamma'_0$  shown in figure 8.

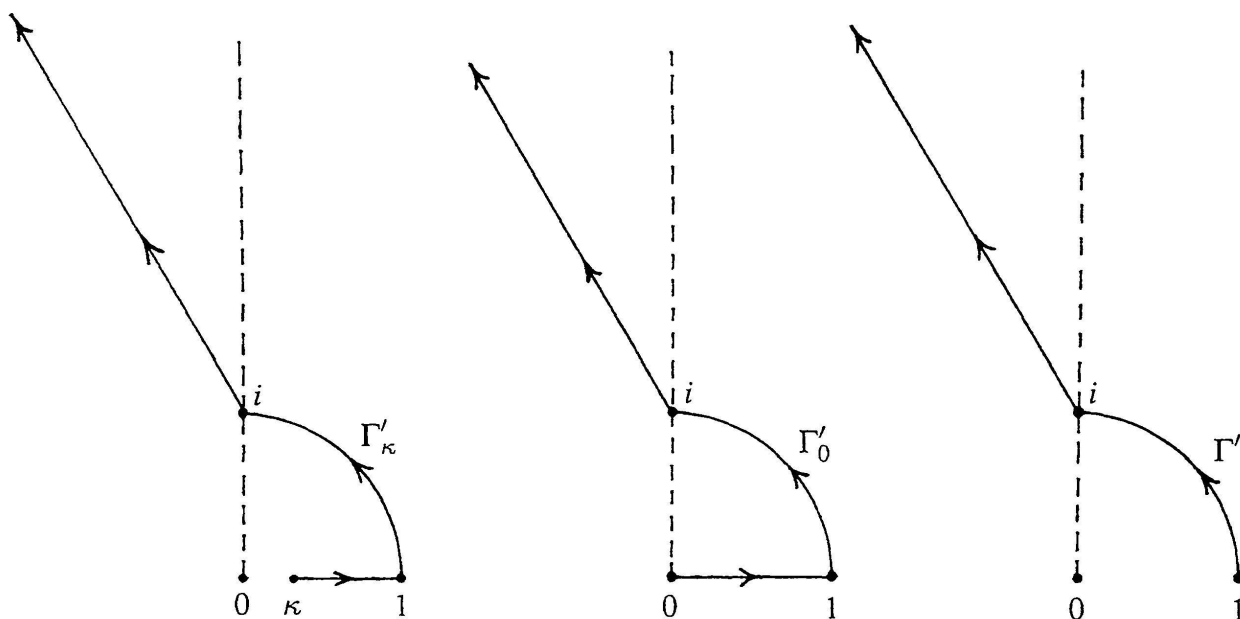

FIGURE 8

The conditions mentioned at the end of §3 do hold for this contour  $\Gamma'_0$  and the function  $g(z) = z^{-2l-2} e^{-2/z}$ , provided that  $r > 0$ . The function  $\omega(r, 0)$  thus has the property just stated.

Finally,

$$(51) \quad \omega'(r, \kappa^2) \longrightarrow \omega'(r, 0)$$

uniformly on any compact interval in  $(0, \infty)$  (sic!) as  $\kappa \rightarrow 0$ . Showing this again gives us trouble when  $l = 0$ , so we replace  $\Gamma_\kappa$  in (41) by the path  $\Gamma'_\kappa$  illustrated in figure 8; we have then to verify that

$$(52) \quad \int_{\Gamma'_\kappa} \left( \frac{z - \kappa}{z + \kappa} \right)^{1/\kappa} \frac{ze^{rz}}{(z^2 - \kappa^2)^{l+1}} dz \longrightarrow \int_{\Gamma'_0} \frac{e^{-2/z} e^{rz}}{z^{2l+1}} dz$$

in the manner stated when  $\kappa \rightarrow 0$ . That is done by arguing as we did above for  $w(r, \kappa^2)$ ; one considers separately the portions of the left-hand integral taken over the *upper part*,  $\Gamma'$ , of  $\Gamma'_\kappa$  (see figure 8) and over the segment  $[\kappa, 1]$ .

Referring to (40), (49), (50) and (51) we see by the above discussion that we have proved

**THEOREM 3.** *When  $\kappa \rightarrow 0$ , the function  $w_2(r, \kappa^2)$  given by (39) tends uniformly on any bounded interval of  $[0, \infty)$  to*

$$(53) \quad w_2(r, 0) = -2 \operatorname{Re} \int_{\Gamma_0} \frac{e^{-2/z} e^{rz}}{z^{2l+2}} dz,$$

*a solution, for  $r > 0$ , of (21) with  $\kappa = 0$ . At the same time,  $w'_2(r, \kappa^2)$  tends uniformly on any compact interval in  $(0, \infty)$  to  $w'_2(r, 0)$ . And we have*

$$(54) \quad w_2(0, 0) = -\frac{(2l)!}{2^{2l}}.$$

(The reader is reminded that, in (53),  $\Gamma_0$  consists of  $(0, 1]$  followed by the curve  $\Gamma$  shown in figure 7.)

It is worthwhile to note that when  $l = 0$ , the convergence of  $w'_2(r, \kappa^2)$  to  $w'_2(r, 0)$  for  $\kappa \rightarrow 0$  *will not be uniform* in bounded intervals of the form  $(0, r_0)$ . One can show (using, e.g., Jordan's lemma) that the right-hand member of (52) is equal to the *improper integral*

$$\int_{\Gamma_0} \frac{e^{-2/z} e^{rz}}{z} dz$$

when  $l = 0$ ; here the integral over the *vertical portion* of  $\Gamma_0$  is understood as

$$\lim_{A \rightarrow \infty} \int_1^A \frac{e^{2i/y} e^{riy}}{y} dy.$$

The last expression behaves like  $\log(1/r)$  for small  $r > 0$ . Appearance of the logarithm is of course to be expected here because the two roots of the indicial equation for (14) differ by an integer (see [11], p. 160 ff); when  $l \geq 1$  the logarithm will again be found in the higher order derivatives of  $w_2(r, 0)$ .



8. A bit more information about the behaviour of  $w_2(r, \kappa^2)$  for  $\kappa \rightarrow 0$  will be needed for a correct argument along the lines of [3].

It was seen in §1 and at the end of §4 that  $u(r, \kappa^2)$  (the solution to (6) constructed in §1),  $u'(r, \kappa^2)$ ,  $w_1(r, \kappa^2)$  and  $w_1'(r, \kappa^2)$  are all *analytic* in  $\kappa^2$  for  $\kappa$  near 0. This implies in particular that the *derivatives with respect to  $\nu$  of those functions* (equal to  $-\kappa^2 \frac{\partial}{\partial \kappa}$  of each of them) *all tend to zero as  $\nu \rightarrow \infty$* . We shall need to know this and, moreover, to be assured that  $w_2(r, \kappa^2)$  and  $w_2'(r, \kappa^2)$  enjoy the same property (when  $r > 0$ ). The last two functions, however, are *not analytic*<sup>1)</sup> in  $\kappa^2$  (at 0), so for them a special examination is required.

As in the preceding §, we work with the function  $\omega(r, \kappa^2)$  given by (41) and related to  $w_2(r, \kappa^2)$  by (40). According to (42),  $\omega(r, \kappa^2)$  can be expressed as the sum of *two* integrals of which the *second*, equal to (45) is, as noted immediately after that formula, *analytic* in  $\kappa^2$  for  $\kappa$  near 0. Our only concern, then, is with the *first* integral on the right in (42), equal, as we noted in the last §, to

$$(55) \quad J(r, \kappa^2) = \int_{\kappa}^1 \left(1 - \frac{2\kappa}{x + \kappa}\right)^{\nu-l-1} \frac{e^{rx}}{(x + \kappa)^{2l+2}} dx.$$

Let us work out  $\frac{\partial J(r, \kappa^2)}{\partial \nu} = -\kappa^2 \frac{\partial J(r, \kappa^2)}{\partial \kappa}$ . Since the integrand in (55) vanishes for  $x = \kappa$ , we have

$$(56) \quad \begin{aligned} \kappa^2 \frac{\partial J(r, \kappa^2)}{\partial \kappa} &= -2\kappa^2(\nu - l - 1) \int_{\kappa}^1 \left(1 - \frac{2\kappa}{x + \kappa}\right)^{\nu-l-2} \frac{xe^{rx}}{(x + \kappa)^{2l+4}} dx \\ &\quad - (2l + 2)\kappa^2 \int_{\kappa}^1 \left(1 - \frac{2\kappa}{x + \kappa}\right)^{\nu-l-1} \frac{e^{rx}}{(x + \kappa)^{2l+3}} dx \\ &\quad - \int_{\kappa}^1 \left(1 - \frac{2\kappa}{x + \kappa}\right)^{\nu-l-1} \cdot \log\left(1 - \frac{2\kappa}{x + \kappa}\right) \cdot \frac{e^{rx}}{(x + \kappa)^{2l+2}} dx. \end{aligned}$$

Taken by themselves, the *first two* integrals on the right are analogous to the one in (55), studied in the last §; as  $\kappa \rightarrow \infty$ , *each* tends to the *finite* quantity

$$\int_0^1 \frac{e^{-2/x} e^{rx}}{x^{2l+3}} dx.$$

The *first two* right-hand terms in (56) are therefore  $O(1/\nu)$  and  $O(1/\nu^2)$  respectively when  $\nu \rightarrow \infty$ , and we turn to the *third* one.

<sup>1)</sup> See Addendum at the end of this paper

For the latter, we observe that  $0 < 1 - \frac{2\kappa}{x + \kappa} < 1$  for  $x > \kappa$ , making

$$\left| \left( 1 - \frac{2\kappa}{x + \kappa} \right) \log \left( 1 - \frac{2\kappa}{x + \kappa} \right) \right| \leq \frac{1}{e}$$

on  $(\kappa, 1]$ . The *integrand* in

$$(57) \quad \int_{\kappa}^1 \left( 1 - \frac{2\kappa}{x + \kappa} \right)^{\nu-l-1} \cdot \log \left( 1 - \frac{2\kappa}{x + \kappa} \right) \cdot \frac{e^{rx}}{(x + \kappa)^{2l+2}} dx$$

is therefore bounded in absolute value by

$$\frac{1}{e} \left( 1 - \frac{2\kappa}{x + \kappa} \right)^{\nu-l-2} \frac{e^{rx}}{(x + \kappa)^{2l+2}}$$

on the range of integration. But now we find, working as in the last §, that the last expression is in turn bounded above by

$$(58) \quad \frac{e^{-1/2x} e^{rx}}{e x^{2l+2}},$$

say, for  $x > \kappa$  and large  $\nu$ . On the other hand,

$$\log \left( 1 - \frac{2\kappa}{x + \kappa} \right) \rightarrow 0 \quad \text{as } \kappa \rightarrow 0$$

for each  $x > 0$ . Therefore, since (58) is integrable on  $[0, 1]$ , the quantity (57) tends to zero by dominated convergence as  $\nu \rightarrow \infty$ .

Each right-hand term in (56) thus tends to zero as  $\nu \rightarrow \infty$ , and we have  $\frac{\partial J(r, 1/\nu^2)}{\partial \nu} \rightarrow 0$  for  $\nu \rightarrow \infty$ .

Going back once more to (42) we see by our initial observations that  $\partial \omega(r, 1/\nu^2) / \partial \nu \rightarrow 0$  as  $\nu \rightarrow \infty$ , whence

$$(59) \quad \frac{\partial w_2(r, 1/\nu^2)}{\partial \nu} \rightarrow 0 \quad \text{for } \nu \rightarrow \infty.$$

By very similar considerations which we hardly need dwell on, one shows that for  $r > 0$  (N.B.!),

$$(60) \quad \frac{\partial^2 w_2(r, 1/\nu^2)}{\partial \nu \partial r} \rightarrow 0 \quad \text{as } \nu \rightarrow \infty;$$

it is only necessary to note that when  $l = 0$ , one should replace the *second* integral on the right in (42) by one over  $\Gamma'$  (see figure 8). In such fashion we arrive at

THEOREM 4. For the function  $w_2(r, \kappa^2)$  defined by (39) we have (59) for  $r \geq 0$  and (60) for  $r > 0$ .

9. From the solutions  $w_1(r, \kappa^2)$  and  $w_2(r, \kappa^2)$  of (21) constructed in §§4, 6 we obtain, by (20), two corresponding ones to (14) (where  $\lambda = \kappa^2$ ), namely

$$(61) \quad v_1(r, \kappa^2) = \frac{w_1(r, \kappa^2)}{r^l}, \quad v_2(r, \kappa^2) = \frac{w_2(r, \kappa^2)}{r^l}.$$

When  $\kappa \rightarrow 0$  these tend respectively to solutions  $v_1(r, 0)$ ,  $v_2(r, 0)$  of (14) for  $\lambda = 0$ , and the *manner* of that convergence can be read off from the results in §4, from Theorem 3 in §7 and from Theorem 4 in the last §.

The functions  $v_1(r, \kappa^2)$ ,  $v_2(r, \kappa^2)$  are linearly independent for  $1/\kappa > l+1$ , including for  $\kappa = 0$ . To see this, take  $r = 0$  in (39) and note that then the path of integration  $[\kappa, \kappa + i\infty)$  used there can be turned down to the real axis (by Cauchy's theorem; cf. the justification of (50)). In that way, we find that

$$w_2(0, \kappa^2) = -2 \int_{\kappa}^{\infty} \left( \frac{x - \kappa}{x + \kappa} \right)^{1/\kappa} \frac{dx}{(x^2 - \kappa^2)^{l+1}},$$

with the right side obviously  $< 0$ . Thus,

$$v_2(r, \kappa^2) \sim \frac{w_2(0, \kappa^2)}{r^l} \quad \text{for } r \rightarrow 0$$

with  $w_2(0, \kappa^2) \neq 0$ , whilst

$$v_1(r, \kappa^2) \sim \frac{2\pi}{(2l+1)!} r^{l+1} \quad \text{for } r \rightarrow 0$$

(including for  $\kappa = 0$ ) by (28). Linear independence of  $v_1$  and  $v_2$  is hence clear when  $\kappa > 0$ , and (54) shows that the property *persists* when  $\kappa = 0$ .

LEMMA. When  $\lambda > 0$ , a solution  $v(r, \lambda)$  of (14) decays exponentially as  $r \rightarrow \infty$  if and only if it is of the form

$$(62) \quad c(v_1(r, \lambda) \cos \pi\nu + v_2(r, \lambda) \sin \pi\nu)$$

with some constant  $c$ . All other solutions of (14) grow exponentially as  $r \rightarrow \infty$ . (As usual,  $\nu = 1/\sqrt{\lambda}$ .)

*Proof.* It follows from Theorem 2 (end of §6) that it is *sufficient* for  $v(r, \lambda)$  to be in the form (62) in order that it decay exponentially.

For the *necessity*, take any solution  $v(r, \lambda)$  of (14), assumed to have exponential decay, and note that since  $v_1(r, \lambda)$  and  $v_2(r, \lambda)$  are linearly independent solutions of (14), we have

$$(63) \quad v(r, \lambda) = av_1(r, \lambda) + bv_2(r, \lambda)$$

with constants  $a, b$ .

In the case where  $\sin \pi\nu \neq 0$  we can choose  $c$  in (62) so as to make  $c \sin \pi\nu = b$ ; subtraction of (62) from (63) will then show, thanks again to Theorem 2, that  $(a - c \cos \pi\nu)v_1(r, \lambda)$  also decays exponentially when  $r \rightarrow \infty$ . As observed in §4,  $v_1(r, \lambda)$  is a constant multiple of the usual series solution to (14) obtained in books on quantum mechanics; the elementary discussion of that solution found in those books (see, e.g., p. 83 of [1]) shows, however, that  $v_1(r, \lambda)$  grows exponentially with  $r$  unless  $1/\sqrt{\lambda} = \nu$  is an integer. Here,  $\sin \pi\nu \neq 0$ . Therefore  $a - c \cos \pi\nu = 0$  and the right side of (63) coincides with (62).

Consider now what happens when  $\sin \pi\nu = 0$ . Then  $\cos \pi\nu = \pm 1$  and we can adjust  $c$  in (62) to make  $c \cos \pi\nu = a$ ; in this case we find from (63) and (62) that  $bv_2(r, \lambda)$  must decay exponentially when  $r \rightarrow \infty$ . Since  $\nu = 1/\sqrt{\lambda}$  is now an integer, we know that  $v_1(r, \lambda)$  must be of the form  $r^{l+1}e^{-\kappa r}p(r)$  with a certain polynomial  $p(r)$  (see, e.g., pp. 80–86 of [1]). For values of  $r$  beyond the last zero of  $p(r)$ ,  $bv_2(r, \lambda)$  can be obtained from  $v_1$  by an elementary formula already used near the end of §1, viz.,

$$bv_2(r, \lambda) = Av_1(r, \lambda) + Bv_1(r, \lambda) \int_{r_0}^r \frac{ds}{(v_1(s, \lambda))^2};$$

here  $r_0$  is any suitably large quantity and  $A, B$  are constants (see [11], p. 122). But we see immediately from this relation that when  $v_1(r, \lambda)$  has the special form just indicated,  $bv_2(r, \lambda)$  must grow exponentially with  $r$  unless  $B = 0$ , i.e., unless  $bv_2(r, \lambda) = Av_1(r, \lambda)$ . Linear independence of  $v_1$  and  $v_2$  then implies that  $A = b = 0$  so, since  $\sin \pi\nu = 0$ , the right side of (63) must coincide with (62).

This reasoning has in fact shown that  $v(r, \lambda)$ , given by (63), will actually grow exponentially as  $r \rightarrow \infty$  unless it is of the form (62). The lemma is proved.

**COROLLARY.** Let  $r_0 > 0$ . When  $\lambda > 0$ , a solution  $v(r, \lambda)$  of (14) is in  $L_2(r_0, \infty)$  if and only if it has the form (62) with  $\nu = 1/\sqrt{\lambda}$ .

**10.** Now we can return to the argument of Hartree already sketched in §2. The proper values  $\lambda = \kappa^2$  for the differential equation (6) are determined by the conditions that its solution  $u(r, \lambda)$  constructed in §1 be in  $L_2(0, \infty)$  and that  $u'(r, \lambda) - (u(r, \lambda)/r)$  also be quadratically integrable on  $(0, \infty)$  (see just before Theorem 1 in §1).

In the circumstances of the present article, *fulfillment of the first condition implies that of the second one*. Any continuous function  $u(r, \lambda)$  is indeed in  $L_2(0, a)$  for each finite  $a > 0$  and that is also true of  $u(r, \lambda)/r$  when (7) holds. If (6) and (7) *both* hold, substitution of the latter into the former followed by integration shows that  $u'(r, \lambda)$  is bounded on  $(0, a)$  and hence in  $L_2(0, a)$ . It therefore remains to check that  $u'(r, \lambda)$  and  $u(r, \lambda)/r$  are in  $L_2(a, \infty)$  when  $u(r, \lambda)$  is.

By (6) that is again true for  $u(r, \lambda)/r$  when  $a > 0$ , and we are left finally with  $\int_a^\infty (u'(r, \lambda))^2 dr$ . Given that  $\int_a^\infty (u(r, \lambda))^2 dr < \infty$ , the derivative  $d(u(r, \lambda))^2/dr$ , continuous by (6), *cannot*, for any  $\varepsilon > 0$ , be eventually always  $> \varepsilon$  or  $< -\varepsilon$  when  $r \rightarrow \infty$ ; there is thus an increasing sequence of  $r_n$  tending to  $\infty$  such that  $u(r_n, \lambda)u'(r_n, \lambda) \rightarrow_n 0$ . We have, however,

$$\int_a^{r_n} (u'(r, \lambda))^2 dr = u'(r_n, \lambda)u(r_n, \lambda) - u'(a, \lambda)u(a, \lambda) - \int_a^{r_n} u''(r, \lambda)u(r, \lambda) dr.$$

Here  $u''(r, \lambda)$ , like  $u(r, \lambda)$ , is in  $L_2(a, \infty)$  by (6), so the integral on the right remains bounded by Schwarz' inequality when  $r_n \rightarrow \infty$ . At the same time, the integrated terms tend to  $-u'(a, \lambda)u(a, \lambda)$  by choice of the sequence  $\{r_n\}$ , and we have  $\int_a^\infty (u'(r, \lambda))^2 dr < \infty$ .

Our conditions on  $u(r, \lambda)$  thus boil down to the requirement that  $u(r, \lambda)$  be in  $L_2(0, \infty)$  or, what comes to the same thing here, in  $L_2(a, \infty)$  for some  $a > 0$  (see above). We *know*, however, that *for large  $r$ , beyond the support of  $\phi(r)$ ,  $u(r, \lambda)$  must coincide with some solution  $v(r, \lambda)$  of (14) and therefore be of the form (63)*. Our conditions for  $\lambda$  to be a proper value of (6) therefore amount to a stipulation that this continuation,  $v(r, \lambda)$ , of  $u(r, \lambda)$  *be in  $L_2(a, \infty)$  for some  $a > 0$  (beyond the support of  $\phi(r)$ ), and now the corollary at the end of the last § shows that this happens if and only if  $v(r, \lambda)$  has the form (62)*. For  $\lambda = 1/\nu^2$  to be a proper value of (6) it is therefore necessary and sufficient (at least when  $\nu > l + 1$ , see Theorem 2) that

$$(64) \quad u(r, \lambda) = c(v_1(r, \lambda) \cos \pi\nu + v_2(r, \lambda) \sin \pi\nu)$$

with some constant  $c$ , for all sufficiently large  $r$ .

From (64) we immediately get

$$(65) \quad u'(r, \lambda) = c(v_1'(r, \lambda) \cos \pi\nu + v_2'(r, \lambda) \sin \pi\nu)$$

(for large  $r$ ). This relation and the preceding one already serve to determine the small proper values  $\lambda > 0$  of (6). *It will indeed suffice to take (64) and (65) with  $r$  set equal to one suitably large quantity  $r_0$ , chosen at pleasure.*

According to a standard uniqueness theorem (see [6], pp. 6–7 or [11], pp. 62–71), the quantities  $u(r_0, \lambda)$ ,  $u'(r_0, \lambda)$  cannot both vanish, for otherwise  $u(r, \lambda)$ , satisfying (7), would be identically zero. Also,

$$v_1(r_0, \lambda)v_2'(r_0, \lambda) - v_1'(r_0, \lambda)v_2(r_0, \lambda) \neq 0$$

on account of the *linear independence* of  $v_1$  and  $v_2$  (beginning of preceding §). The last expression, called the Wronskian of  $v_1$  and  $v_2$ , is actually independent of  $r_0$  (see [6], p. 7). From this it follows that we can put  $r = r_0$  in (64) and (65) and then *solve for the ratio*

$$\cos \pi\nu : \sin \pi\nu$$

in terms of the other quantities involved in those relations.

When that is done,  $c$  disappears and  $\cos \pi\nu : \sin \pi\nu$  works out to

$$(66) \quad \left( v_2'(r_0, \lambda)u(r_0, \lambda) - v_2(r_0, \lambda)u'(r_0, \lambda) \right) : \\ \left( -v_1'(r_0, \lambda)u(r_0, \lambda) + v_1(r_0, \lambda)u'(r_0, \lambda) \right).$$

From the observations just made, it follows that *both terms of this ratio cannot vanish*. Supposing that *the second does not*, we will have

$$(67) \quad \cot \pi\nu = \frac{v_2'(r_0, \lambda)u(r_0, \lambda) - v_2(r_0, \lambda)u'(r_0, \lambda)}{-v_1'(r_0, \lambda)u(r_0, \lambda) + v_1(r_0, \lambda)u'(r_0, \lambda)},$$

and in the *contrary situation*, we get

$$(68) \quad \tan \pi\nu = \frac{-v_1'(r_0, \lambda)u(r_0, \lambda) + v_1(r_0, \lambda)u'(r_0, \lambda)}{v_2'(r_0, \lambda)u(r_0, \lambda) - v_2(r_0, \lambda)u'(r_0, \lambda)}.$$

Now it follows from the results in §§1,4 and from Theorem 3 (end of §7) that the terms of the ratio (66) tend respectively to

$$v_2'(r_0, 0)u(r_0, 0) - v_2(r_0, 0)u'(r_0, 0) \quad \text{and to} \quad -v_1'(r_0, 0)u(r_0, 0) + v_1(r_0, 0)u'(r_0, 0)$$

when  $\kappa \rightarrow 0$ ; here the above remarks about  $u$ ,  $u'$  and the Wronskian  $v_1v_2' - v_1'v_2$  *still apply*, so the last two limiting expressions *also cannot both vanish*.

*If it is the second that does not*, we put

$$(69) \quad C = \frac{v_2'(r_0, 0)u(r_0, 0) - v_2(r_0, 0)u'(r_0, 0)}{-v_1'(r_0, 0)u(r_0, 0) + v_1(r_0, 0)u'(r_0, 0)}$$

and then recognize that

$$(70) \quad C(\nu) = \frac{v_2'(r_0, 1/\nu^2)u(r_0, 1/\nu^2) - v_2(r_0, 1/\nu^2)u'(r_0, 1/\nu^2)}{-v_1'(r_0, 1/\nu^2)u(r_0, 1/\nu^2) + v_1(r_0, 1/\nu^2)u'(r_0, 1/\nu^2)},$$

the right side of (67), is certainly *defined* for large  $\nu$  and *must tend to*  $C$  as  $\nu \rightarrow \infty$  by the results just referred to.

For *large* integers  $n$ ,  $C(\nu)$  *must therefore be close to*  $C$  when  $n < \nu < n + 1$ ; on the other hand,  $\cot \pi \nu$  *decreases from*  $\infty$  *to*  $-\infty$  as  $\nu$  runs through  $(n, n + 1)$ . We can thus expect to have a value  $\nu_n$  of  $\nu$ ,  $n < \nu_n < n + 1$ , for which (67) *holds*, yielding the proper value  $\lambda = 1/\nu_n^2$  of (6). Since  $C(\nu_n)$  is close to  $C$ ,  $\nu_n - n$  will be near to  $(1/\pi) \text{arc cot } C$ .

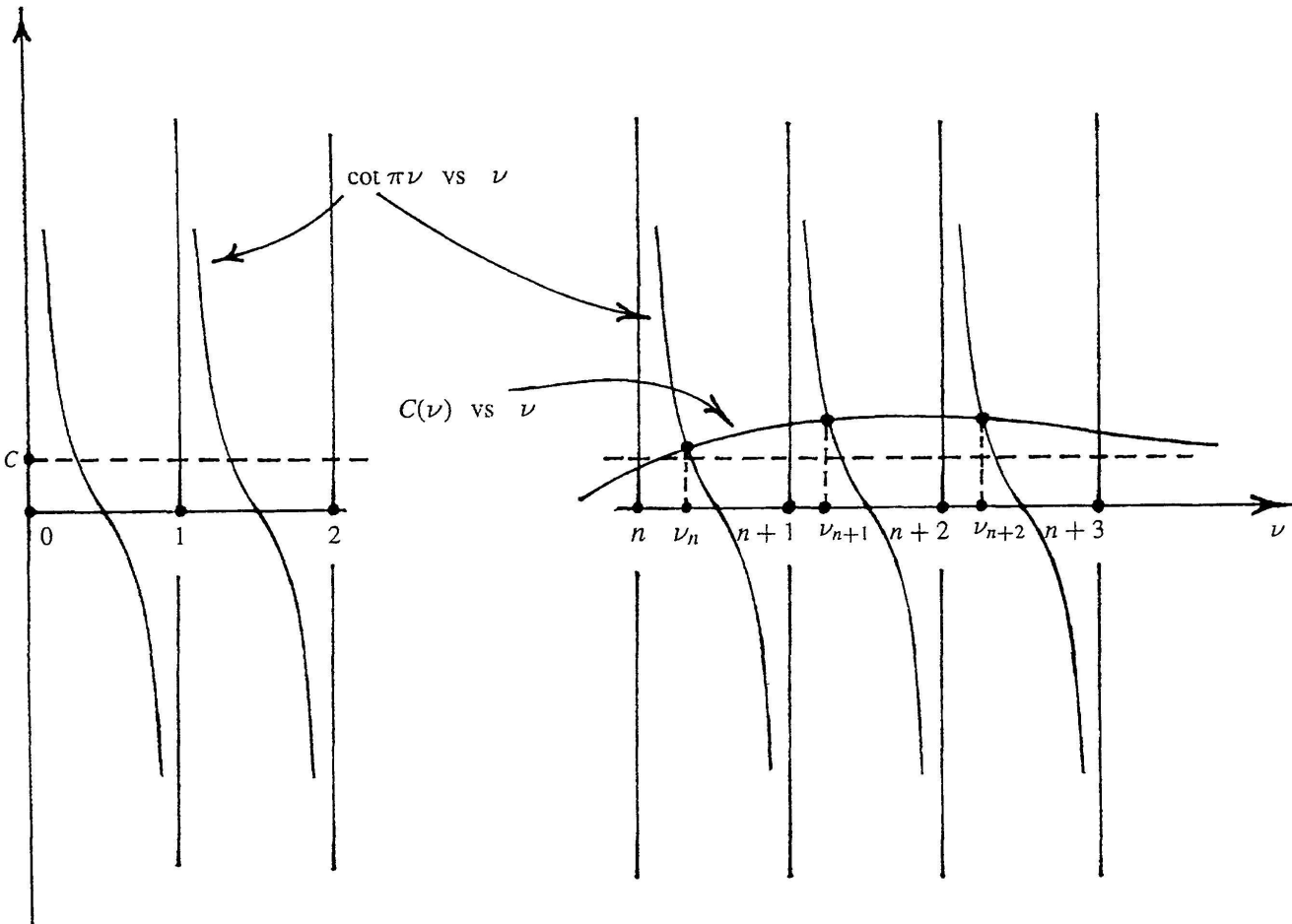

FIGURE 9

It is claimed that, in the present circumstances, *the equation*  $\cot \pi \nu = C(\nu)$  *has precisely one root*  $\nu_n$  *in each interval*  $(n, n + 1)$  *corresponding to a sufficiently large value of the integer*  $n$  (see figure 9).

It is for this that we need the material from § 8. According to the remarks at the beginning of that §, each of the four partial derivatives

$$\frac{\partial u(r_0, 1/\nu^2)}{\partial \nu}, \quad \frac{\partial u'(r_0, 1/\nu^2)}{\partial \nu}, \quad \frac{\partial v_1(r_0, 1/\nu^2)}{\partial \nu}, \quad \frac{\partial v'_1(r_0, 1/\nu^2)}{\partial \nu}$$

tends to 0 as  $\nu \rightarrow \infty$ , and by Theorem 4 that is also true for

$$\frac{\partial v_2(r_0, 1/\nu^2)}{\partial \nu} \quad \text{and} \quad \frac{\partial v_2'(r_0, 1/\nu^2)}{\partial \nu}.$$

Now when we refer to (70) we see that  $dC(\nu)/d\nu$  is the sum of a number of terms, each involving one of the preceding six derivatives as a factor. There is also a *denominator* equal to the square of the one in (70), but the latter tends to the denominator in (69), *here assumed to be non-zero*, when  $\nu \rightarrow \infty$ , and is thus *bounded away from 0 for large  $\nu$* . It follows that

$$(71) \quad \frac{dC(\nu)}{d\nu} \longrightarrow 0 \quad \text{as } \nu \longrightarrow \infty.$$

On the other hand,  $\cot \pi \nu$  decreases from  $\infty$  to  $-\infty$  in each interval  $(n, n+1)$ , with

$$\frac{d \cot \pi \nu}{d\nu} \leq -\pi$$

there. This, and (71), show that the *difference*  $\cot \pi \nu - C(\nu)$  will be strictly monotone in  $(n, n+1)$  when  $n$  is large and therefore, since  $C(\nu) \rightarrow C$  for  $\nu \rightarrow \infty$ , *have precisely one zero,  $\nu_n$ , in that interval*. The above claim is confirmed and we see moreover that  $\cot \pi(\nu_n - n) = \cot \pi \nu_n \rightarrow C$  for  $n \rightarrow \infty$ , making

$$\nu_n - n \longrightarrow \frac{1}{\pi} \text{arc cot } C, \quad n \rightarrow \infty.$$

We must not forget to take up the case where *the denominator in (69) does vanish*. But *then the numerator on the right side of that formula is not zero*, and we can go through an argument like the one just made, based, however, on (68) instead of (67). It is found that for sufficiently large integers  $n$ , (68) has *precisely one solution  $\nu_n$  in each interval  $(n - \frac{1}{2}, n + \frac{1}{2})$* , and that

$$\nu_n - n \longrightarrow 0 \quad \text{for } n \rightarrow \infty.$$

*In the whole of the preceding development, the quantity  $l$  has been taken as fixed*; that means that *the differences  $\nu_n - n$  really depend on the value of  $l$  in (6) as well as on  $n$* . In order to remind ourselves of this dependence, we write

$$(72) \quad \Delta_l(n) = \nu_n - n.$$

Then the conclusions reached in this § can be summarized in



THEOREM 5. *The smaller proper values  $\lambda > 0$  of (6) are all given by the formula*

$$(73) \quad \lambda = \frac{1}{(n + \Delta_l(n))^2},$$

where  $-\frac{1}{2} < \Delta_l(n) < 1$  and  $n$  runs through all the larger integers. If the denominator in (69) is not zero,  $0 < \Delta_l(n) < 1$  and

$$(74) \quad \Delta_l(n) \longrightarrow \Delta_l = \frac{1}{\pi} \text{arc cot } C \quad \text{as } n \rightarrow \infty,$$

with  $C$  given by (69). If that denominator is zero,  $-\frac{1}{2} < \Delta_l(n) < \frac{1}{2}$ , and (74) holds with  $\Delta_l = 0$ .

The small proper values of (6) are thus nearly of the form  $1/(n + \Delta_l)^2$ , and we have arrived at what is essentially Rydberg's empirical result.

Our proof of the last theorem has relied especially on Hartree's fundamental relation (38), as well as on the properties of  $w_1$  and  $w_2$  established in §§4, 7 and 8. In [3], Hartree obtained his relation by first using the method of Frobenius to get explicit expansions of  $w_1(r, \kappa^2)$  and  $w_2(r, \kappa^2)$  in powers of  $r$  (involving also  $\log r$  for the second function), and then comparing his results with a similar series expansion of what amounts to  $w_3(r, \kappa^2)$ . This approach has been taken up again in more recent publications, sometimes without mention of [3]; see, for instance, [4], [7] and [9].

11. For a long time physicists have preferred to work not with  $\Delta_l(n)$ , but with

$$(75) \quad \delta_l(m_l + n) = m_l - \Delta_l(n),$$

where  $m_l$  is some positive integer depending on  $l$ . They also put

$$(76) \quad \delta_l = m_l - \Delta_l = \lim_{n \rightarrow \infty} \delta_l(m_l + n)$$

(see (74)), and it is  $\delta_l$  that is called the *quantum defect*.

Introduction of the integer  $m_l$  enables us to adapt (73) so as to get, in pure ad hoc fashion, a representation of *all* the proper values  $\lambda > 0$  of (6) and not just the smaller ones. The original restriction of (73) to the *larger values* of  $n$  was due to two limitations in our procedure. Considering, for example, a case where  $\Delta_l > 0$ , i.e., where the denominator in (69) is not zero, we were required, in the discussion of the last §, to work with large values of  $\nu$  for

which the behaviour of  $C(\nu)$ , given by (70), had *settled down*; for smaller values of  $\nu$  the denominator in (70) might pass several times through the value 0. This inconvenience could be dealt with by alternating between uses of (67) and (68), but then there is another problem: in §6, our verification that  $w_2(r, \kappa^2)$  was a solution of (21) (and hence  $v_2(r, \kappa^2)$  a solution of (14)) *required us to take*  $\nu > l + 1$ . We may, however, *need* to use (73) with  $n < l + 1$  in order to get *all* the proper values of (6). The  $2p$  state of lithium, for example has an energy corresponding to the  $\lambda$  given by (73) with  $n = 1$  and  $\Delta_1(1)$  about 0.96; here the value of  $l + 1$  is 2.

Let us substitute (75) into (73) and then replace  $m_l + n$  by  $n$ ; we get

$$(77) \quad \lambda = \frac{1}{(n - \delta_l(n))^2},$$

and if (73) has been *proven* to be valid for  $n \geq M$ , say, (77) will hold for  $n \geq m_l + M$ .

But there could also be a finite number of *larger* proper values  $\lambda$ , *not described* by (73) with  $n \geq M$ , and hence not given by (77) with  $n \geq m_l + M$ . Supposing that there are  $N$  of these, we need only take  $m_l$  so as to have  $M + m_l > N$ , and then we can represent them by (77) with  $n$  equal successively to  $M + m_l - N$ ,  $M + m_l - N + 1, \dots, M + m_l - 1$ , after assigning appropriate values to  $\delta_l(n)$  for these  $n$ .

In such (trivial) fashion, (77) can be set up so as to accommodate all the proper values of (6), and by going through the procedure for each  $l$  we get a formula representing all the proper values of (3). For each  $l$  the limit  $\delta_l$  in (76) *exists* (by Theorem 5), and the corresponding proper values  $\lambda$  are given asymptotically by  $1/(n - \delta_l)^2$  with  $n \rightarrow \infty$ .

A certain arbitrariness is obviously associated with the manner just indicated of choosing  $m_l$ , so it may not be amiss to note that it *seems* possible, *at least in principle*, to arrive at a rational determination of that quantity by the methods of the present article. An attempt to carry this through properly runs up against serious difficulties; let us nonetheless suggest a procedure which is perhaps feasible.

The idea is simple enough. *Fixing again*  $l$ , we replace the function  $\phi(r) \geq 0$  standing in (6) (and, without loss of generality, *not identically zero*) by  $\tau\phi(r)$ , introducing a parameter  $\tau$  allowed to range from 0 to 1. That gives us

$$(78) \quad \frac{d^2u(r)}{dr^2} + \left( \frac{2}{r} + \frac{\tau\phi(r)}{r} - \frac{l(l+1)}{r^2} - \lambda \right) u(r) = 0,$$

and the proper values  $\lambda$  of this differential equation will now depend on  $\tau$ .

For  $\tau = 0$ , (78) reduces to (14), the radial Schrödinger equation for hydrogen, having, as we know, the proper values  $\lambda = 1/n^2$  with  $n = l + 1, l + 2, \dots$  (see [1], pp. 80–86). We fix a large value of  $n$  and take the proper value  $\lambda_n^{(0)} = 1/n^2$  of (78) corresponding to  $\tau = 0$ . As  $\tau$ , starting from 0, gradually increases,  $\lambda_n^{(0)}$  turns into a proper value  $\lambda_n^{(\tau)}$  of (78) whose variation with  $\tau$  can be described by a standard perturbation formula, viz.,

$$(79) \quad \frac{d\lambda_n^{(\tau)}}{d\tau} = \frac{\int_0^\infty (\phi(r)/r)(u_\tau(r, \lambda_n^{(\tau)}))^2 dr}{\int_0^\infty (u_\tau(r, \lambda_n^{(\tau)}))^2 dr};$$

here  $u_\tau(r, \lambda_n^{(\tau)})$  is the solution of (78) obtained by the procedure of §1 and corresponding to the value  $\lambda = \lambda_n^{(\tau)}$ . For a rigorous justification of (79), see [12], pp. 247–251.

What (79) shows in the present circumstances is that  $\lambda_n^{(\tau)}$  continually increases with  $\tau$ . Comparing it with the initial value  $\lambda_n^{(0)}$  we can therefore write

$$(80) \quad \lambda_n^{(\tau)} = \frac{1}{(n - \delta_l^{(\tau)}(n))^2}$$

with a quantity  $\delta_l^{(\tau)}(n)$ , also increasing as  $\tau$  does, and such that  $\delta_l^{(0)}(n) = 0$ .

When  $\tau$  has increased to 1 the corresponding proper value  $\lambda_n^{(1)}$  of (78) must coincide with one of the proper values of (6) and hence be given by (73) if  $n$  is large; we will thus have

$$(81) \quad \lambda_n^{(1)} = \frac{1}{(m + \Delta_l(m))^2}$$

with a certain (large) integer  $m$ . Comparing (80) and (81) we hence find that  $\delta_l^{(1)}(n) = n - m - \Delta_l(m)$ , i.e., writing just  $\delta_l(n)$  for  $\delta_l^{(1)}(n)$  and  $m_{l,n}$  for  $n - m$ , that

$$\delta_l(n) = m_{l,n} - \Delta_l(n - m_{l,n}).$$

Here the integer  $m_{l,n}$  depends on both indices, but I think it very plausible that it should become constant (for fixed  $l$ ) when  $n$  is large. To see why that should be the case, let us imagine the graphs of  $\lambda_n^{(\tau)}$ ,  $\lambda_{n+1}^{(\tau)}$ , etc. versus  $\tau$  for  $0 \leq \tau \leq 1$ , each lying below its predecessor. (It seems very likely that those graphs cannot cross or touch each other.) Each one starts at a point  $(0, 1/n^2)$  and ends at a point  $(1, \lambda_n^{(1)})$  with  $\lambda_n^{(1)}$  equal to one of the values on the right in (81). On the other hand, any such value (for  $m$  large) is the

ordinate of the right end-point of one of the graphs. Taking, indeed, such a value  $\lambda_m = \lambda_m(1)$ , we note that it is a proper value of (78) corresponding to  $\tau = 1$ . We can now let  $\tau$  diminish from 1 to 0; that gives us a changing proper value  $\lambda_m(\tau)$  of (78), equal to  $\lambda_m(1)$  for  $\tau = 1$  and varying according to the appropriate version of (79). When  $\tau$  arrives at the value 0 we end with a proper value  $\lambda_m(0)$  of (14), necessarily equal to  $1/n^2$  for some  $n \geq l + 1$ .

Thinking of the pattern formed by these graphs and considering, especially, that the  $\Delta_l(m)$  are all practically equal to  $\Delta_l$  for large  $m$ , one cannot help believing that  $m_{l,n}$  must stay constant when  $n$  is large. If that is indeed so, we may denote the constant value by  $m_l$  and, in that way, arrive at (75). I find this argument convincing, but must own that it falls short of a real proof. If it could be made rigorous, we would have a natural procedure for the specification of  $m_l$ .

Would that procedure, should it prove legitimate, give us a *large enough* value of  $m_l$  to make the ad hoc one outlined at the beginning of this § work, i.e., to make (77), used in conjunction with (75), represent *all* the proper values of (6)? That would evidently depend on our having a suitable limitation on the quantity  $N$  involved in the discussion of (77).

If the second approach is sound, it should, for *concrete* choices of the function  $\phi(r)$ , yield values of  $m_l$  agreeing with those obtained by the numerical treatment of (6). Experience shows that the values of  $m_l$  obtained in that way are always large enough to work in the ad hoc procedure, but this fact cannot be explained using the methods of the present article. It is a consequence of *the smallness of  $N$*  which, in turn, depends on the architecture of atomic structure and finally on the Pauli exclusion principle. One of the things leading up to that principle was indeed Bohr's early estimate of some of the "true" values of  $\delta_l$  for sodium, made with help of the old quantum theory.

12. All the proper values  $\lambda$  of (6) are thus given by (77) (beginning of last §), and if, in that relation, we let  $l$  run through the values  $0, 1, 2, \dots$ , we get all the proper values of (3). The quantities  $\delta_l(n)$  are close to their respective limits  $\delta_l$  when  $n$  is large and, *in actual fact*, even when  $n$  is *not so large*, so that the approximate formula

$$\lambda \simeq \frac{1}{(n - \delta_l)^2}$$

(essentially Rydberg's original one) can be used with fair accuracy to get all the values of  $\lambda$ .

It is nevertheless important to gain more precision by describing the actual dependence of  $\delta_l(n)$  on  $n$ . A long time ago Ritz gave an empirical relation

$$\delta_l(n) = \delta_l + \frac{a_l}{n^2}$$

which, in many cases, works very well; an improvement of this is

$$(82) \quad \delta_l(n) = \delta_l + \frac{a_l}{(n - \delta_l)^2} + \frac{b_l}{(n - \delta_l)^4}.$$

One reason for the closeness of Rydberg's original formula to the truth is that these refinements do *not* involve a term behaving like  $1/n$  for large  $n$ .

Such representations are, as we shall see, implied by our charge cloud model. Let us write

$$(83) \quad \nu(n) = n - \delta_l(n)$$

(keeping, as usual,  $l$  fixed). One should not confound  $\nu(n)$  with  $\nu_n$ , the quantity involved in the reasoning of §10. Referring to (72) and (75) we see that  $\nu(n)$  and  $\nu_n$  are related by the formula

$$(84) \quad \nu_n = \nu(n + m_l).$$

We shall obtain an *asymptotic development*

$$(85) \quad \delta_l(n) = \delta_l + \frac{a_l}{(\nu(n))^2} + \frac{b_l}{(\nu(n))^4} + \dots$$

for  $\delta_l(n)$  in terms of  $\nu(n)$ ; here  $a_l, b_l, \dots$  are certain constants and *only even powers of  $1/\nu(n)$  are involved on the right*. The series does *not* generally converge, but if it is broken off after the term in  $(\nu(n))^{-2p}$ , the error will be  $O((\nu(n))^{-2p-2})$  for large  $n$ .

We see from (83) that the approximation

$$\delta_l(n) \simeq \delta_l + \frac{a_l}{(\nu(n))^2}$$

differs from Ritz' original one by  $O(1/n^3)$  for large  $n$ , and that the sum of the first 3 terms in (85) differs from the right side of (82) by  $O(1/n^5)$ . Expressions like (82) are currently employed, with (77), in spectroscopy and, suitably adapted to take account of electron spin, represent energy levels with very great accuracy. Regarding this the reader may consult p. 351 of [5] and the table on p. 353 therein. (That table has an obvious misprint in the entry of  $\delta_1$  for lithium; a nought is missing between the decimal point and what follows it.) Let us proceed to deduce (85) using the methods of this paper.

We shall find it convenient to obtain a formula equivalent to (85) for  $\Delta_l(n) = m_l - \delta_l(n + m_l)$ ; according to (75), (76) and (84) such a formula must read

$$(86) \quad \Delta_l(n) = \Delta_l - \frac{a_l}{\nu_n^2} - \frac{b_l}{\nu_n^4} - \dots$$

This being intended as an *asymptotic* development we may, in deriving it, confine our attention to *large* values of  $n$ , and that puts the material of §10 at our disposal. We return, therefore to the relations (67), (68), (69) and (70) used in that § to determine  $\Delta_l(n) = \nu_n - n$ .

It will be enough to go through the treatment of the case where the denominator in (69) is not zero; then  $\nu_n$  is obtained for large  $n$  by solving (67) (with  $\lambda = 1/\nu^2$ ). As we have seen,  $\nu_n$  in this circumstance is the unique root of the equation  $\cot \pi \nu = C(\nu)$  lying in  $(n, n+1)$ , where  $C(\nu)$  is given by (70). Here,  $\Delta_l(n)$  is simply the fractional part of  $\nu_n$ , so we will have

$$\Delta_l(n) = \frac{1}{\pi} \text{arc cot } C(\nu_n).$$

Now when  $n$  is *large*,  $C(\nu_n) - C$  will be *small*, and we can expand the right side of the preceding formula in powers of this difference. According to (74), that will yield

$$\Delta_l(n) = \Delta_l + A_1(C(\nu_n) - C) + A_2(C(\nu_n) - C)^2 + \dots,$$

and we see that (86) will follow *provided that we obtain an asymptotic development*

$$C(\nu) = C + \frac{c_1}{\nu^2} + \frac{c_2}{\nu^4} + \dots$$

for  $C(\nu)$  in powers of  $1/\nu^2$ . The rest of our work is directed towards that goal.

Looking at (69) and (70), we see that  $C(\nu)$  would have an actual *expansion* of the desired kind if *each* of the six functions appearing on the right in (70) were *analytic in  $1/\nu^2$  at  $\infty$* . For  $u(r_0, 1/\nu^2)$ ,  $u'(r_0, 1/\nu^2)$ ,  $v_1(r_0, 1/\nu^2)$  and  $v_1'(r_0, 1/\nu^2)$  that is indeed *true* by work in §1 and the corresponding results about  $w_1(r, \kappa^2)$  noted near the end of §4. But  $v_2(r_0, 1/\nu^2)$  and  $v_2'(r_0, 1/\nu^2)$  *also* figure in (70) and they are *not analytic*<sup>2)</sup> in  $1/\nu^2$  (at  $\infty$ ). *Instead*, they have, as we shall now prove, *asymptotic developments* in powers of that quantity. And *that is enough*, together with the analyticity of the other four functions, to guarantee such a development for  $C(\nu)$ .

<sup>2)</sup> See Addendum at the end of this paper

From (61) and (40) we have

$$v_2(r_0, \kappa^2) = \frac{w_2(r_0, \kappa^2)}{r_0^l} = -2 \frac{\operatorname{Re} \omega(r_0, \kappa^2)}{r_0^l},$$

where  $\omega(r_0, \kappa^2)$  is given by (41) (in §7). The property in question therefore holds for  $v_2(r_0, 1/\nu^2)$  and  $v_2'(r_0, 1/\nu^2)$  thanks to

**THEOREM 6.** *If  $r > 0$ ,  $\omega(r, \kappa^2)$  and  $\omega'(r, \kappa^2)$  both have asymptotic developments in powers of  $\kappa^2$ , valid when  $\kappa \rightarrow 0$ .*

*Proof.* Considering first the function  $\omega(r, \kappa^2)$ , we use (42) to write it as the sum of two integrals, the second equal to the one in (45). The latter is even analytic in  $\kappa^2$  as remarked just after (45), so it remains – and that is our main work – to establish an asymptotic development in powers of  $\kappa^2$  for the first right-hand integral in (42), that is, for

$$(87) \quad J(r, \kappa^2) = \int_{\kappa}^1 \left( \frac{x - \kappa}{x + \kappa} \right)^{1/\kappa} \frac{e^{rx}}{(x^2 - \kappa^2)^{l+1}} dx.$$

In order to study this integral, we split it up further into two, one over  $(\kappa, \kappa^\alpha)$  and the other over  $[\kappa^\alpha, 1]$ , where  $\alpha$  is a fixed exponent with  $0 < \alpha < 2/3$ . To estimate the first of those, we can follow the procedure used to treat (47), getting, for  $\nu > 2(l + 1)$ ,

$$(88) \quad \int_{\kappa}^{\kappa^\alpha} \left( \frac{x - \kappa}{x + \kappa} \right)^{1/\kappa} \frac{e^{rx}}{(x^2 - \kappa^2)^{l+1}} dx = \int_{\kappa}^{\kappa^\alpha} \left( 1 - \frac{2\kappa}{x + \kappa} \right)^{\nu-l-1} \frac{e^{rx}}{(x - \kappa)^{2l+2}} dx \\ \leq \int_{\kappa}^{\kappa^\alpha} \frac{e^{-2(1-(l+1)\kappa)/(x+\kappa)} e^{rx}}{(x + \kappa)^{2l+2}} dx \leq \int_{\kappa}^{\kappa^\alpha} \frac{e^{-1/2x} e^{rx}}{x^{2l+2}} dx = O(e^{-1/3\kappa^\alpha})$$

for  $\kappa \rightarrow 0$ .

The other contribution to  $J(r, \kappa^2)$  is

$$(89) \quad \int_{\kappa^\alpha}^1 \left( \frac{x - \kappa}{x + \kappa} \right)^{1/\kappa} \frac{e^{rx}}{(x^2 - \kappa^2)^{l+1}} dx,$$

and our idea now is to use (43) in this integral, with  $\theta(z)$  given by (44) and  $z = x$ . That can be done. Relation (44) can indeed be rewritten thus:

$$(90) \quad \theta(x) = \frac{(l+1)\kappa^2}{x^2} \left( 1 + \frac{1}{2} \left( \frac{\kappa}{x} \right)^2 + \frac{1}{3} \left( \frac{\kappa}{x} \right)^4 + \dots \right) \\ - \frac{2\kappa^2}{x^3} \left( \frac{1}{3} + \frac{1}{5} \left( \frac{\kappa}{x} \right)^2 + \frac{1}{7} \left( \frac{\kappa}{x} \right)^4 + \dots \right).$$

When  $\kappa \rightarrow 0$ , the factor  $\kappa^2/x^3$  and the ratio  $(\kappa/x)^2$  occurring in each of the series on the right *tend uniformly to zero for*  $x \geq \kappa^\alpha$ . This means, in the first place, that the expansion (43) can safely be employed in (89), yielding for that integral the value

$$(91) \quad \int_{\kappa^\alpha}^1 \frac{e^{-2/x} e^{rx}}{x^{2l+2}} \left( 1 + \theta(x) + \frac{(\theta(x))^2}{2!} + \frac{(\theta(x))^3}{3!} + \dots \right) dx.$$

From (90) we see in the second place that  $\theta(x)$  is uniformly  $O(\kappa^2/x^3)$  for small  $\kappa > 0$  and  $1 \geq x \geq \kappa^\alpha$ . If, therefore, we *break off* the series appearing in (91) *after, say, the term*  $(\theta(x))^p/p!$ , we make an error in the integral bounded above by

$$O(\kappa^{2p+2}) \int_0^1 \frac{e^{-2/x} e^{rx}}{x^{2l+3p+5}} dx = O(\kappa^{2p+2})$$

in absolute value. The integral (91) is therefore equal to

$$(92) \quad \sum_{m=0}^p \frac{1}{m!} \int_{\kappa^\alpha}^1 \frac{e^{-2/x} e^{rx}}{x^{2l+2}} (\theta(x))^m dx + O(\kappa^{2p+2})$$

for small  $\kappa > 0$ .

Let us now fix a value for the integer  $p$ . Then we must obtain a development, up to terms in  $\kappa^{2p}$  and with error  $O(\kappa^{2p+2})$ , for each of the integrals involved in the summation in (92). For that purpose we look again at (90) and observe that it can be expressed as

$$(93) \quad \theta(x) = \frac{(l+1)\kappa^2}{x^2} \left( \sum_{j=0}^{p-1} \frac{1}{j+1} \left(\frac{\kappa}{x}\right)^{2j} + \frac{1+o(1)}{p+1} \left(\frac{\kappa}{x}\right)^{2p} \right) \\ - \frac{2\kappa^2}{x^3} \left( \sum_{j=0}^{p-1} \frac{1}{2j+3} \left(\frac{\kappa}{x}\right)^{2j} + \frac{1+o(1)}{2p+3} \left(\frac{\kappa}{x}\right)^{2p} \right),$$

with  $o(1)$  terms tending *uniformly* to zero for  $1 \geq x \geq \kappa^\alpha$  and  $\kappa \rightarrow 0$ . Using this finitary representation, we see that each integral of the form

$$\int_{\kappa^\alpha}^1 \frac{e^{-2/x} e^{rx}}{x^{2l+2}} (\theta(x))^m dx,$$

$0 \leq m \leq p$ , is equal to a sum

$$(94) \quad \sum_{j=1}^p \kappa^{2j} \int_{\kappa^\alpha}^1 \frac{e^{-2/x} e^{rx}}{x^{2l+2}} R_{j,m}(1/x) dx + O(\kappa^{2p+2}) \int_{\kappa^\alpha}^1 \frac{e^{-2/x} e^{rx}}{x^{L_m}} dx,$$



where the  $R_{j,m}(1/x)$  are certain *polynomials* in  $1/x$  and  $L_m$  is some (usually quite large) exponent depending on  $m$  (and  $p$ ). Here the remainder term is again  $O(\kappa^{2p+2})$  (see above) so, using the expressions (94) in (92), we find for the latter the value

$$(95) \quad \sum_{j=0}^p \kappa^{2j} \int_{\kappa^\alpha}^1 \frac{e^{-2/x} e^{rx}}{x^{2l+2}} R_j(1/x) dx + O(\kappa^{2p+2})$$

with *polynomials*  $R_j(1/x)$  in  $1/x$ . It is clear that these *polynomials* are precisely the ones that would be obtained if we simply substituted (90) into the expansion  $e^{\theta(x)} = \sum_{m=0}^{\infty} (\theta(x))^m / m!$  and then grouped together all the terms involving each power  $\kappa^{2j}$ .

We now replace each of the  $p$  integrals figuring in (95) by the corresponding quantity

$$(96) \quad \int_0^1 \frac{e^{-2/x} e^{rx}}{x^{2l+2}} R_j(1/x) dx = s_j,$$

*finite* and independent of  $\kappa$ . Doing this, we make an *error* of at most  $O(e^{-1/3\kappa^\alpha})$  – cf. (88). The expression (92) thus works out, by (95), to

$$\sum_{j=0}^p s_j \kappa^{2j} + O(\kappa^{2p+2}) + O(e^{-1/3\kappa^\alpha});$$

this, then is an evaluation of (91), i.e., of (89).

Referring now to (88) we see finally that

$$J(r, \kappa^2) = \sum_{j=0}^p s_j \kappa^{2j} + O(\kappa^{2p+2}) + O(e^{-1/3\kappa^\alpha}),$$

and here  $e^{-1/3\kappa^\alpha}$  is certainly  $O(\kappa^{2p+2})$  for each exponent  $p$  when  $\kappa \rightarrow 0$ . In this formula, moreover, the  $s_j$  do not depend on the integer  $p$ ; that follows from the above observation about the *polynomials*  $R_j(1/x)$  figuring in (95) and (96). We have thus established the asymptotic development

$$(97) \quad J(r, \kappa^2) = s_0 + s_1 \kappa^2 + s_2 \kappa^4 + \dots,$$

valid for  $\kappa \rightarrow 0$ . As noted at the beginning of this proof, (97) immediately yields a similar development for  $\omega(r, \kappa^2)$ .

It remains to deduce the same kind of development for  $\omega'(r, \kappa^2)$ , and it is here that we need  $r > 0$  when  $l = 0$ . Discussion of  $J'(r, \kappa^2)$  proceeds

exactly as above and may be omitted. The only change in our work consists of the insertion of a factor  $x$  in the integral on the right in (87) and in each of the integrals deriving therefrom, and one arrives at the analogue of (97) for  $J'(r, \kappa^2)$  without further ado.

In treating  $d/dr$  of the *second* right-hand integral in (42) it is better, when  $l = 0$ , to replace the path  $\Gamma$  used there by  $\Gamma'$ , shown in figure 8. The formulas (43) and (44) can be used in the resulting integral, and show it to be an analytic function of  $\kappa^2$  when  $r > 0$ .

Proof of the theorem is now complete. Before going further, and coming to the end of this paper, it is worthwhile to point out that the development (97), the same as

$$\sum_{j=0}^{\infty} \kappa^{2j} \int_0^1 \frac{e^{-2/x} e^{rx}}{x^{2l+2}} R_j(1/x) dx,$$

is what we would obtain formally if we substituted (90) into the expansion of  $e^{\theta(x)}$  in powers of  $\theta(x)$ , grouped together all the terms involving each power  $\kappa^{2j}$  and, finally, plugged the resulting series into the (meaningless) formal expression

$$\int_0^1 \frac{e^{-2/x} e^{\theta(x)} e^{rx}}{x^{2l+2}} dx.$$

We now recall the conclusions of the discussion pursued at the beginning of this §. According to them, the last theorem has the

**COROLLARY.** *The asymptotic development (86) holds for each of the functions  $\Delta_l(n)$ .*

This immediately implies the corresponding development (85) for the quantities  $\delta_l(n)$  appearing in (77).

#### ADDENDUM

At the beginning of §9 and again in §12 it was said that the functions  $w_2(r, \kappa^2)$  and  $v_2(r, \kappa^2) = r^{-l} w_2(r, \kappa^2)$  – the first given by (40) – are *not analytic* in  $\kappa^2$  at the point  $\kappa = 0$ . This can be seen by referring to a (complicated) explicit representation of  $v_2(r, \kappa^2)$  in terms of known special functions; one may, for instance, consult pp. 181–184 of [4] and especially

formula (2.35) on p. 181 therein. Although the non-analyticity is not actually *used* in the preceding development, it seems worthwhile to see how it can be verified directly, without resorting to special technical material. Let us do that.

It is enough, in light of the observation at the beginning of the proof of Theorem 6 (§12), to show that the function  $J(r, \kappa^2)$  given by (87), viz.,

$$J(r, \kappa^2) = \int_{\kappa}^1 \left( \frac{x - \kappa}{x + \kappa} \right)^{1/\kappa} \frac{e^{rx}}{(x^2 - \kappa^2)^{l+1}} dx,$$

is not even analytic in  $\kappa$  at the point  $\kappa = 0$ . For  $0 < \kappa < \min(1, 1/l)$  this function has an expansion *in powers of  $r$  with coefficients depending on  $\kappa$* , and it suffices to show that *the latter are not all analytic at  $\kappa = 0$* . In fact, the first  $2l + 1$  of them *are* (they can be easily computed), and we have to go out to the coefficient of  $r^{2l+1}$  in order to observe failure of analyticity. Here we only consider the case where  $l = 0$  so as to keep things simple. The treatment for larger values of  $l$  is very similar, but *a bit* more involved.

Taking, then,  $l = 0$ , we look at the value of

$$\frac{\partial J(r, \kappa^2)}{\partial r} - \kappa J(r, \kappa^2) = \int_{\kappa}^1 \left( \frac{x - \kappa}{x + \kappa} \right)^{1/\kappa} \frac{e^{rx}}{x + \kappa} dx,$$

for  $r = 0$ , that is, at

$$A(\kappa) = \int_{\kappa}^1 \left( \frac{x - \kappa}{x + \kappa} \right)^{1/\kappa} \frac{dx}{x + \kappa}.$$

With  $(x - \kappa)/(x + \kappa) = s$ , this becomes

$$(98) \quad A(\kappa) = \int_0^{\frac{1-\kappa}{1+\kappa}} \frac{s^{1/\kappa}}{1-s} ds,$$

and we wish to show that the function  $A(\kappa)$ , so far only defined for  $0 < \kappa < 1$ , *cannot thence be extended into any neighbourhood of 0 so as to be analytic therein*.

For  $0 < \kappa < 1$  we have  $0 < (1 - \kappa)/(1 + \kappa) < 1$  and the expansion of  $1/(1-s)$  in powers of  $s$  can be substituted into the right side of (98), yielding

$$(99) \quad A(\kappa) = \left( \frac{1 - \kappa}{1 + \kappa} \right)^{1/\kappa} \sum_{n=1}^{\infty} \frac{((1 - \kappa)/(1 + \kappa))^n}{(1/\kappa) + n}.$$

Here,

$$\left( \frac{1 - \kappa}{1 + \kappa} \right)^{1/\kappa} = \exp\left(-2 - \frac{2\kappa^2}{3} - \frac{2\kappa^4}{5} - \dots\right)$$

(cf. in §4), a function obviously analytic (in  $\kappa^2$ ) for  $|\kappa| < 1$  (with  $\kappa$  complex). Hence  $A(\kappa)$  can be extended from  $(0, 1)$  so as to be analytic near 0 if and only if

$$(100) \quad B(\kappa) = \sum_{n=1}^{\infty} \frac{((1 - \kappa)/(1 + \kappa))^n}{(1/\kappa) + n}$$

can be so extended.

The series in (100) converges uniformly on any compact set of (complex)  $\kappa$  in the open right half plane, since  $|(1 - \kappa)/(1 + \kappa)| < 1$  precisely in that region. The function  $B(\kappa)$ , initially specified only for  $0 < \kappa < 1$ , thus has an *analytic* extension to the half plane  $\text{Re } \kappa > 0$ . To ensure analyticity of a corresponding extension of  $A(\kappa)$ , we should further require  $|\kappa| < 1$  (see above); we can thus be sure that  $A(\kappa)$  has, at any rate, an analytic extension from  $(0, 1)$  to the half-disk

$$\mathcal{D}_+ = \{\kappa; \text{Re } \kappa > 0 \text{ and } |\kappa| < 1\},$$

and continues to be given by (99) therein.

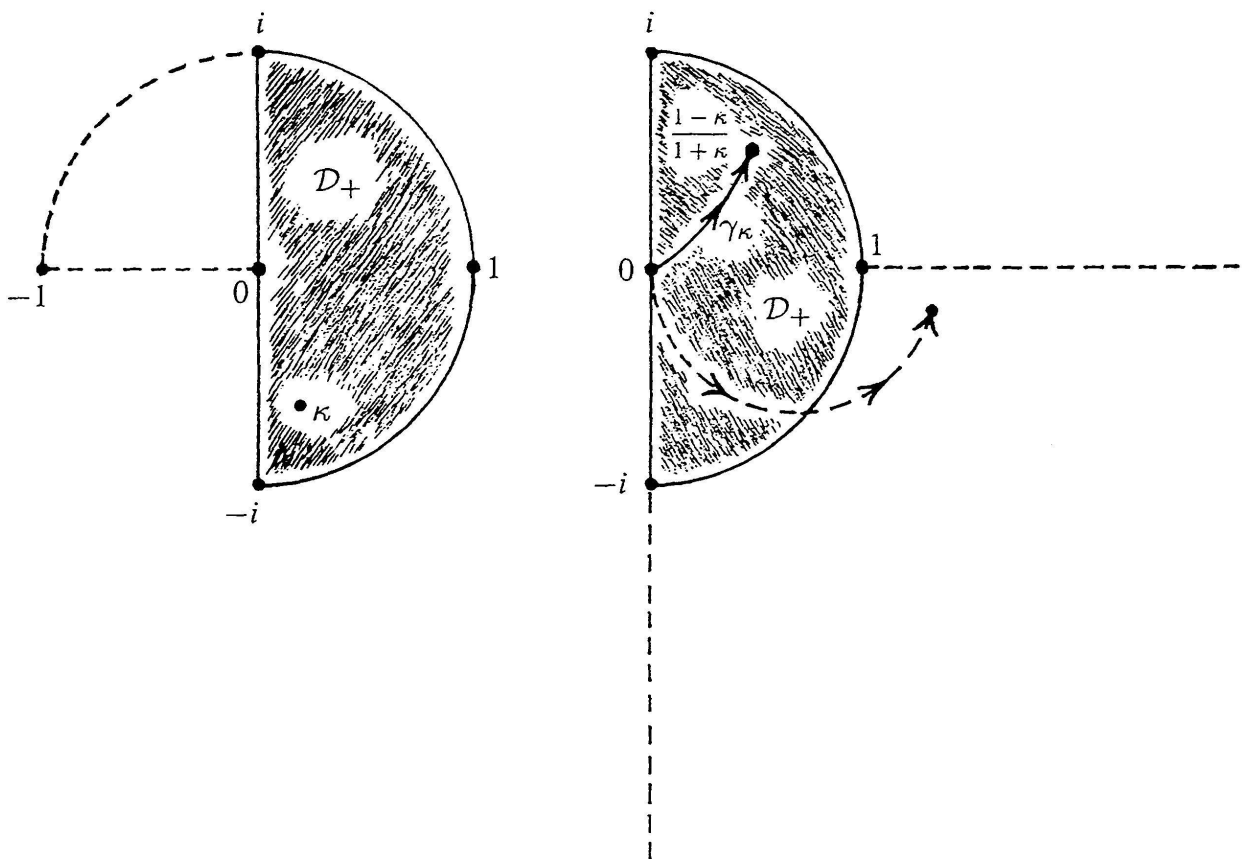

FIGURE 10

The transformation  $\kappa \rightarrow (1 - \kappa)/(1 + \kappa)$  takes  $\mathcal{D}_+$  conformally onto itself so, for  $\kappa \in \mathcal{D}_+$ , we have paths  $\gamma_\kappa$  lying in  $\mathcal{D}_+$  (save for their initial endpoints) and running from 0 out to  $(1 - \kappa)/(1 + \kappa)$  (see figure 10). Referring to (99) we see that a version of (98) holds for  $\kappa \in \mathcal{D}_+$ ; we have, namely,

$$(101) \quad A(\kappa) = \int_{\gamma_\kappa} \frac{s^{1/\kappa}}{1-s} ds,$$

where  $\gamma_\kappa$  is any of the paths just described. (In integrals like the one on the right,  $s^{1/\kappa}$  is understood to be obtained from the principal branch of  $\log s$ .)

Take now any integer  $m > 1$ ; then (101) can be rewritten

$$A(\kappa) = \sum_{n=0}^{m-1} \int_{\gamma_\kappa} s^{(1/\kappa)+n} ds + \int_{\gamma_\kappa} \frac{s^{(1/\kappa)+m}}{1-s} ds,$$

that is,

$$(102) \quad A(\kappa) = \left(\frac{1-\kappa}{1+\kappa}\right)^{1/\kappa} \sum_{n=1}^m \frac{((1-\kappa)/(1+\kappa))^n}{(1/\kappa)+n} + \int_{\gamma_\kappa} \frac{s^{(1/\kappa)+m}}{1-s} ds.$$

And this formula, valid for  $\kappa \in \mathcal{D}_+$ , enables us to continue  $A(\kappa)$  analytically across the segment  $(0, i)$ , from  $\mathcal{D}_+$  into the intersection of the open unit disk with the second quadrant (excluding the negative real axis).

Let, indeed,  $C$  be any compact set passing, across  $(0, i)$ , from  $\mathcal{D}_+$  into the second region; then  $|1/\kappa|$  will be bounded for  $\kappa \in C$  and hence  $\operatorname{Re}(1/\kappa)$  bounded below there, so, if the integer  $m$  in (102) is large enough,  $\operatorname{Re}(1/\kappa)+m$  will be  $> -1$  on  $C$ . For such  $\kappa$ , on  $(0, i)$  or beyond it,  $(1 - \kappa)/(1 + \kappa)$  will lie in the open fourth quadrant, and there will be paths  $\gamma_\kappa$  like the dotted one shown in figure 10, lying in the fourth quadrant and going from 0 out to  $(1 - \kappa)/(1 + \kappa)$  while avoiding the point 1. The integral in (102) will thus make sense with such paths  $\gamma_\kappa$  for  $\kappa \in C$ , and obviously continue to represent an analytic function of  $\kappa$  there. At the same time, the sum in (102) will remain analytic for  $\kappa$  in the second quadrant, not on the real axis, and with  $|\kappa| < 1$ .

It is now claimed that when  $\kappa$ , in the open second quadrant, tends to any point  $-1/p$ ,  $p = 2, 3, \dots$ , the function  $A(\kappa)$ , specified in the way just described, tends to  $\infty$ . Fixing any such  $p$ , we can choose an integer  $m > p$  such that (102) will be valid for the  $\kappa$  in question, with indeed

$\operatorname{Re}(1/\kappa) + m > -1$  and bounded away from  $-1$  as  $\kappa \rightarrow -1/p$ . For the  $\gamma_\kappa$  we can take *circular arcs* lying in the fourth quadrant, *orthogonal to the real axis* and running from  $0$  to  $(1 - \kappa)/(1 + \kappa)$ ; these  $\gamma_\kappa$  will stay away from  $1$  while  $(1 - \kappa)/(1 + \kappa) \rightarrow (p + 1)/(p - 1)$ , i.e., while  $\kappa \rightarrow -1/p$ . Then  $|1 - s|$  will be uniformly bounded away from  $0$  for  $s$  on these  $\gamma_\kappa$ , and the *integral* in (102) thus *remain bounded* as  $\kappa \rightarrow -1/p$ . At the same time, however, the *sum* in (102) will tend to  $\infty$  like  $1/((1/\kappa) + p)$ . Hence  $A(\kappa)$  will tend to  $\infty$  as  $\kappa \rightarrow -1/p$  in the manner described.

This being so for *each* of the points  $-1/p$ ,  $p = 2, 3, \dots$ ,  $A(\kappa)$  can have *no analytic continuation from  $\mathcal{D}_+$  into any neighbourhood of  $0$* , since any such continuation would have to coincide with the one just constructed on the intersection of the open second quadrant with the neighbourhood in question. That is what we needed to prove.

Before concluding, I must again thank my friend Victor Havin for having, during a conversation, expressed a thought which, indirectly, got me onto a path leading to the above argument.

#### BIBLIOGRAPHY

- [1] SCHIFF, L. I. *Quantum Mechanics*. McGraw-Hill, New York, 1955.
- [2] MARGENAU, H. and G. M. MURPHY. *The Mathematics of Physics and Chemistry*. Van Nostrand, New York, 1943.
- [3] HARTREE, D. R. The wave mechanics of an atom with a non-Coulomb central field. Part III. Term values and intensities in series in optical spectra. *Proc. Camb. Phil. Soc.* 24 (1928), 426–437.
- [4] SEATON, M. J. Quantum defect theory. *Reports Prog. Phys.* 46 (1983), 167–257.
- [5] GALLAGHER, T. F. *Rydberg Atoms*. Cambridge Univ. Press, 1994.
- [6] TITCHMARSH, E. C. *Eigenfunction Expansions*. Oxford, Clarendon Press, 1946.
- [7] HAM, F. S. The quantum defect method. In: *Solid State Physics*, edited by Seitz and Turnbull. Vol. 1 (1955), 127–192. Academic Press, New York.
- [8] MOTT, N. F. and H. S. W. MASSEY. *The Theory of Atomic Collisions*. Oxford, Clarendon Press; 2nd edition, 1949; 3rd edition, 1965.
- [9] FANO, U. and A. R. P. RAU. *Atomic Collisions and Spectra* Academic Press, Orlando, 1986.
- [10] RAU, A. R. P. and M. INOKUTI. The quantum defect: Early history and recent developments. *Amer. J. Phys.* 65:3 (1997), 221–225.
- [11] INCE, E. L. *Ordinary Differential Equations*. Dover, New York, 1956.

- [12] TITCHMARSH, E. C. *Eigenfunction Expansions*. Part II. Oxford, Clarendon Press, 1958.
- [13] SHUBOV, M. A. Asymptotic behavior of the quantum defect as a function of an angular momentum and almost normalization of eigenfunctions for a three-dimensional Schrödinger operator with nearly Coulomb potential. *Differential Integral Equations* 8: 8 (1995), 1885–1910.

*(Reçu le 25 octobre 1999)*

Paul Koosis

Department of Mathematics & Statistics  
McGill University  
Montreal  
Canada

**vide-leer-empty**