

Approach to equilibrium in an explicit quantum model

Autor(en): **Favre, Christian / Marchand, Jean-Paul**

Objektyp: **Article**

Zeitschrift: **Helvetica Physica Acta**

Band (Jahr): **39 (1966)**

Heft 1

PDF erstellt am: **14.09.2024**

Persistenter Link: <https://doi.org/10.5169/seals-113669>

Nutzungsbedingungen

Die ETH-Bibliothek ist Anbieterin der digitalisierten Zeitschriften. Sie besitzt keine Urheberrechte an den Inhalten der Zeitschriften. Die Rechte liegen in der Regel bei den Herausgebern.

Die auf der Plattform e-periodica veröffentlichten Dokumente stehen für nicht-kommerzielle Zwecke in Lehre und Forschung sowie für die private Nutzung frei zur Verfügung. Einzelne Dateien oder Ausdrucke aus diesem Angebot können zusammen mit diesen Nutzungsbedingungen und den korrekten Herkunftsbezeichnungen weitergegeben werden.

Das Veröffentlichen von Bildern in Print- und Online-Publikationen ist nur mit vorheriger Genehmigung der Rechteinhaber erlaubt. Die systematische Speicherung von Teilen des elektronischen Angebots auf anderen Servern bedarf ebenfalls des schriftlichen Einverständnisses der Rechteinhaber.

Haftungsausschluss

Alle Angaben erfolgen ohne Gewähr für Vollständigkeit oder Richtigkeit. Es wird keine Haftung übernommen für Schäden durch die Verwendung von Informationen aus diesem Online-Angebot oder durch das Fehlen von Informationen. Dies gilt auch für Inhalte Dritter, die über dieses Angebot zugänglich sind.

Approach to Equilibrium in an Explicit Quantum Model¹⁾

by **Christian Favre** and **Jean-Paul Marchand**

Institute of Theoretical Physics, University of Geneva

(28. IX. 65)

Abstract. A quantum mechanical model is introduced which admits true equilibria (no Poincaré cycles) but avoids calculation in infinite product spaces. The existence and uniqueness question of equilibria is solved in various examples and the approach to equilibrium discussed geometrically in the Liouville space of the physical states.

1. Introduction

The aim of this paper is to obtain some insight into irreversible quantum processes approaching an equilibrium state.

It is well-known that the evolution of any finite system is quasiperiodic in time and that true equilibria do not exist (Poincaré cycles). In order to avoid dealing with them we start from the question: Can we construct an *infinite* model without running into the difficulties of working in an infinite tensor product-space? If the answer is yes, an explicit study of the approach to equilibrium will be possible by simple mathematical means.

The model consists roughly of a small system S of interest (for instance one $1/2$ spin) coupled to an infinite reservoir B of identical systems in thermal equilibrium in such a way that S interacts at any given time only with one particle of B and never twice with the same (here the infinity of the “bath” B is used). The evolution of this “collision” model at any moment may thus be described in the product space of only two particles, where, however, the particle of the bath falls back into its initial state after any collision with S . This “loss of memory” of the bath is at the origin of the fact, that the movement of the state of S becomes homogeneous in time and admits true equilibria. It corresponds to the classical “Stosszahlansatz” of BOLTZMANN.

In § 2, we describe in mathematical terms a somehow stylized version of the model (all collisions of equal duration and succeeding each other without interval between them). The Liouville space of states in S is introduced, in order to visualize the evolution of any state geometrically by a line.

¹⁾ Partly supported by the “Fonds national suisse pour la recherche scientifique”.

In § 3 the main questions as to existence and uniqueness of the equilibrium and approach to it will be formulated.

The main part is § 4 where the model is explicitly calculated in the simple case of 1/2-spins and various couplings. It is astonishing to see how strongly the general properties of the time-evolution depend on the coupling Hamiltonian. The following cases arise:

- a) all states of S approach a unique equilibrium which corresponds to the thermal equilibrium of the bath;
- b) all states of S approach a unique equilibrium which however differs from that of the bath;
- c) all states of S approach an equilibrium, but the latter is not unique: some "memory" of the initial state of S persists throughout the motion;
- d) only a subset of states of S approach equilibria (unique or not), the others do not approach an equilibrium at all.

We see from this that already in one of the simplest examples many different types of evolution may occur. The one thing they have in common is the existence of at least one fixpoint as asserted in entire generality by the theorem of MARKOFF-KAKUTANI [1]²⁾.

In § 5 various other properties of the model are discussed in connection with energy, entropy, Markofficity, diagonality.

We conclude with the adaptation of the model to a possible physical situation introducing a mean free path between the collisions. This causes some modifications not only in the way how the systems approach equilibrium but also in the uniqueness question of equilibrium.

2. The Model

Let \mathcal{H}^S , \mathcal{H}^B be the finite Hilbertspaces of systems S and B . The uncoupled states of S and B are described by density matrices W^S and W^B , and they evolve in time according to the free Hamiltonians H_0^S and H_0^B . The bath B is furthermore supposed to be in thermal equilibrium at time $t = 0$:

$$W^B = \frac{e^{-(1/kT) H_0^B}}{\text{Tr} e^{-(1/kT) H_0^B}}. \quad (2.1)$$

From time 0 to Δt a first "collision" takes place between S and B and the total state in $\mathcal{H} = \mathcal{H}^S \otimes \mathcal{H}^B$ develops according to the total Hamiltonian

$$H = H_0^S \otimes I + I \otimes H_0^B + V,$$

where the interaction V couples \mathcal{H}^S and \mathcal{H}^B . The time evolution of the system S of interest during this first collision is thus achieved by the following three steps:

$$\begin{aligned} W_0^S &\xrightarrow{\mathcal{A}} W_0^S \otimes W^B \xrightarrow{\mathcal{U}^{\Delta t}} e^{-iH \Delta t} (W_0^S \otimes W^B) e^{iH \Delta t} \\ &\xrightarrow{\mathcal{R}^S} \text{Tr}(e^{-iH \Delta t} (W_0^S \otimes W^B) e^{iH \Delta t}) \equiv W_{\Delta t}^S \end{aligned} \quad (2.2)$$

²⁾ Numbers in brackets refer to References, page 20.

where the operation \mathcal{A} "amplifies" the state W_0^S into a state $W_0^S \otimes W^B$ in \mathcal{H} (uncoupled systems at $t = 0$), $\mathcal{U}_{\Delta t}$ describes a Schrödinger motion of the states in \mathcal{H} , and \mathcal{R}^S reduces the total state at Δt to the system of interest S . The joint operation

$$\mathcal{U}_{\Delta t}^S \equiv \mathcal{R}^S \mathcal{U}_{\Delta t} \mathcal{A} \quad (2.3)$$

maps thus the matrices of \mathcal{H}^S onto themselves and may be called the propagator 0 to Δt of the state W_0^S .

Now enters the essential hypothesis that the second collision from Δt to $2\Delta t$ takes place between S and a "new particle" of the bath, which was unaffected by the first collision. In other words: the bath at time Δt falls back into the initial state W^B , it loses memory. We obtain thus

$$W_{2\Delta t}^S = \mathcal{R}^S \mathcal{U}_{\Delta t} \mathcal{A} W_{\Delta t}^S = \mathcal{U}_{\Delta t}^S W_{\Delta t}^S = (\mathcal{U}_{\Delta t}^S)^2 W_0^S \equiv \mathcal{U}_{2\Delta t}^S W_0^S$$

and repeating this procedure

$$\mathcal{U}_{n\Delta t}^S = (\mathcal{U}_{\Delta t}^S)^n.$$

Interpolating this operator-function for arbitrary times t we finally define

$$\mathcal{U}_t^S = (\mathcal{U}_{\Delta t}^S)^{t/\Delta t}. \quad (2.4)$$

The *general properties* of \mathcal{U}_t^S are:

- I \mathcal{U}_t^S maps the set \mathcal{C}^S of all states³⁾ in S into itself.
- II The set $\{\mathcal{U}_t^S\}$ of mappings $\mathcal{C}^S \rightarrow \mathcal{C}^S$ (all $t \geq 0$) forms an abelian semi-group⁴⁾, i.e. for any $t_1, t_2 \geq 0$:

$$\mathcal{U}_{t_1+t_2}^S = \mathcal{U}_{t_1}^S \mathcal{U}_{t_2}^S = \mathcal{U}_{t_2}^S \mathcal{U}_{t_1}^S.$$

- III There exists a fix "point" in \mathcal{C}^S with respect to the semi-group, i.e. a state left invariant under any of the mappings \mathcal{U}_t^S .

Proof I. Let W_0^S be a state in \mathcal{H}^S , then $\mathcal{A} W_0^S$ and $\mathcal{U}_t \mathcal{A} W_0^S$ are states in \mathcal{H} . Now, hermiticity, positivity and trace-condition are conserved in the process of reduction. So $\mathcal{U}_{\Delta t}^S W_0^S = \mathcal{R}^S \mathcal{U}_{\Delta t} \mathcal{A} W_0^S$ is still a state in \mathcal{H}^S .

³⁾ A state in \mathcal{H} is defined as a linear operator W in \mathcal{H} with the three properties $W^* = W$ (hermiticity), $W > 0$ (positivity), $\text{Tr } W = 1$ (trace-condition).

⁴⁾ The most characteristic underlying feature of the evolution defined here is its homogeneity in time. In general a propagator depends on both, the initial and the final time t_1 and t_2 ; if the evolution is homogeneous however it depends only on the difference $t_2 - t_1$ and we may write

$$\mathcal{U}_{t_2/t_1} = \mathcal{U}_{t_2-t_1/0} = \mathcal{U}_{t_2-t_1}.$$

As an example of an inhomogeneous situation consider the so called reduced system. (Cf. U. FANO, Rev. Mod. Phys. 29, 74 (1957). U. FANO: Lectures presented at the 5th International Spring School of Physics (Ravello 1963). J. M. JAUCH, Helv. Phys. Acta 37, 293 (1964)). Using our notations its evolution reads

$$W_t^S = \mathcal{R}^S \mathcal{U}_t \mathcal{A} W_0^S \equiv \mathcal{U}_{t/0}^S W_0^S$$

which coincides with (2.3) only for $t = \Delta t$. This evolution, though not Schrödingerian, is quasi-periodic (Poincaré cycles) whenever the space $\mathcal{H} = \mathcal{H}^S \otimes \mathcal{H}^B$ is finite. Furthermore, the semi-group property does not hold, since the group-multiplication of two operators \mathcal{U}_{t_3/t_2} and \mathcal{U}_{t_2/t_1} can only be performed if the intermediate times t_2 and t_3 coincide. The "most general evolution" of a system as defined by JORDAN, PINSKY, and SUDARSHAN in J. M. P. 3, 848 (1962) does in fact not include the case of the reduced systems.

Proof II is an immediate consequence of the definition (2.4) of \mathbf{u}_i^S

$$\mathbf{u}_{t_1}^S \mathbf{u}_{t_2}^S = (\mathbf{u}_{\Delta t}^S)^{t_1/\Delta t} (\mathbf{u}_{\Delta t}^S)^{t_2/\Delta t} = (\mathbf{u}_{\Delta t}^S)^{t_1+t_2/\Delta t} = \mathbf{u}_{t_1+t_2}^S.$$

Proof III follows from (I) and (II) by the theorem of MARKOFF-KAKUTANI [1], since \mathbf{C}^S forms a convex subset of all matrices in \mathcal{H}^S which is invariant under the abelian set $\{\mathbf{u}_i^S\}$. The topological requirements (compactness) of the theorem may be easily verified after introduction of the Liouville space \mathcal{L}^S attached to \mathcal{H}^S (and the topology induced by the norm [2]. The definition of the Liouville space is given below).

As stated in the Introduction the main advantage of the Liouville space consists in the fact, that all states are represented by points in a sphere moving in time under the action of the one-parameter family of "propagators" $\{\mathbf{u}_i^S\}$. In the following it will be useful to use some geometrical notions which we shall define.

Let \mathcal{H} be a (finite) Hilbertspace. The *Liouville space* \mathcal{L} attached to \mathcal{H} is defined by the set of linear operators O in \mathcal{H} satisfying $\text{Tr } O^+ O < \infty$. The scalar product (O, O') is defined by $\text{Tr } O^+ O'$. (For clarity elements in \mathcal{L} will always be denoted by bold type letters.) Let N be the dimension of \mathcal{H} , then $\dim \mathcal{L} = N^2$ and we may choose in \mathcal{L} an *orthonormal basis* V_i ($i = 0, 1, \dots, N^2 - 1$). If we choose furthermore $V_0 = 1/\sqrt{N} \mathbf{I}$ ($1/\sqrt{N}$ is the normalisation factor: $\|V_0\|^2 = 1/N \text{Tr } \mathbf{I}^2 = 1$) the conditions on W to represent a state imply the following relations in \mathcal{L} :

$$\begin{aligned} (V_0, W) &= \frac{1}{\sqrt{N}} \text{Tr } W = \frac{1}{\sqrt{N}} \\ \|W\|^2 &= \text{Tr } W^2 \leq \text{Tr } W = 1. \end{aligned}$$

The first line defines an $(N^2 - 1)$ -dimensional hyperplane \mathcal{Y} in \mathcal{L} orthogonal to V_0 and the second line defines a hypersphere \mathcal{S} of radius 1. The set $\mathcal{C} \subset \mathcal{L}$ of states is a subset of the intersection $\mathcal{Y} \cap \mathcal{S}$ which in turn represents a hypersphere of radius $r = \sqrt{1 - 1/N}$ lying in \mathcal{Y} ; its boundary $\tilde{\mathcal{C}}$ consists of the pure states (Fig. 1).

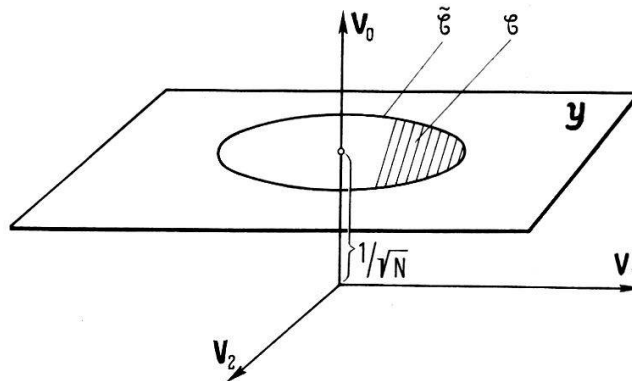

Fig. 1

In N^2 -dimensional Liouville space the physical states are contained in an $(N^2 - 1)$ -dimensional hypersphere \mathcal{C} with radius $r = \sqrt{1 - 1/N}$ whose boundary $\tilde{\mathcal{C}}$ represents the pure states

Consider now the Liouville spaces \mathcal{L}^S , \mathcal{L}^B , \mathcal{L} attached to \mathcal{H}^S , \mathcal{H}^B , and \mathcal{H} and introduce the orthonormal frames V_i^S , V_k^B , $V_{ik} = V_i^S \otimes V_k^B$ with $V_0^S = 1/\sqrt{\dim \mathcal{H}^S} \mathbf{I}$; $V_0^B =$

$1/\sqrt{\dim \mathcal{H}^B} \mathbf{I}$. Let W_i^S, W_k^B be the components of W_0^S, W_0^B ; then we may now write the three operations (2.2)

$$W_0^S = \sum_{i=0}^{N^2-1} W_i^S V_i^S; \quad W^B = \sum_k W_k^B V_k^B$$

$$\mathcal{A} W_0^S = W_0^S \otimes W^B = \sum_{i,k} W_i^S W_k^B V_{ik}$$

$$\mathcal{U}_{\Delta t} \mathcal{A} W_0^S = \sum_{i,k} W_i^S W_k^B \mathcal{U}_{\Delta t} V_{ik}$$

$$\mathcal{U}_{\Delta t}^S W_0^S \equiv \mathcal{R}^S \mathcal{U}_{\Delta t} \mathcal{A} W_0^S = \sum_{i,k,l} W_i^S W_k^B (V_{l0}, \mathcal{U}_{\Delta t} V_{ik}) V_l^S \quad 5)$$

From this follows the geometric interpretation of $\mathcal{U}_{\Delta t}^S$ as an operator in \mathcal{L}^S : $\mathcal{U}_{\Delta t}^S$ is obtained in the steps

- 1) formation of a direct product;
- 2) rotation in the product space \mathcal{L} (note that $\|\mathcal{U}_{\Delta t} W\|_{\mathcal{L}} = \|W\|_{\mathcal{L}}$);
- 3) projection into the plane spanned by the basis-vectors V_{l0} .

The *general definition of motion in \mathcal{L}^S* may be written

$$W_t^S = (\mathcal{U}_{\Delta t}^S)^{t/\Delta t} W_0^S; \quad (\mathcal{U}_{\Delta t}^S)_{li} = \sum_k W_k^B (V_{l0}, \mathcal{U}_{\Delta t} V_{ik}).$$

3. The Main General Questions

We saw that the operations \mathcal{U}_t^S may be interpreted as operators in the Liouville space \mathcal{L}^S attached to \mathcal{H}^S , and that they have the property to map the subset $\mathcal{C}^S \subset \mathcal{L}^S$ into itself, leaving at least one element of \mathcal{C}^S invariant (fixpoint). In order to formulate further questions, let us first introduce the following convenient terminology:

We call $\mathcal{F} \subset \mathcal{C}^S$ the *set of fixpoints* of the operator family $\{\mathcal{U}_t^S\}$. It follows from the homogeneity of \mathcal{U}_t^S that this set is identical to the set of fixpoints of $\mathcal{U}_{\Delta t}^S$. Let W_F^S be an element of \mathcal{F} ; then $\mathcal{C}(W_F^S)$ denotes the *class of states approaching W_F^S for $t \rightarrow \infty$* ; i.e.

$$\mathcal{C}(W_F^S) = \{W^S \in \mathcal{C}^S \mid \lim_{t \rightarrow \infty} \mathcal{U}_t^S W^S = W_F^S\}.$$

W_F^S may be called the *equilibrium for the states in the set $\mathcal{C}(W_F^S)$* .

The following cases may arise:

- 1) \mathcal{F} contains exactly one point W_F^S (unique equilibrium):
 - a) $\mathcal{C}(W_F^S) = \mathcal{C}^S$ (all states tend to the same equilibrium),
 - b) $\mathcal{C}(W_F^S) \subset \mathcal{C}^S$ (there exist states which do not tend to any equilibrium).

⁵⁾ The operation of reduction is given by the well-known formula

$$W \rightarrow W^S = \text{Tr}^B W$$

which transforms an operator acting in \mathcal{H} to an operator acting in \mathcal{H}^S . A simple calculation shows that the corresponding operation in the Liouville space is essentially a projection on a subspace spanned by the 4 basis-vectors V_{l0} :

$$\mathcal{R}^S W = \sum_{i,k,l} W_{ik} (V_{l0}, V_{ik}) V_l^S.$$

- 2) \mathcal{F} contains more than one point (non-unique equilibrium), $\mathcal{C}(W_F^S)$ is then necessarily smaller than \mathcal{C}^S , but the following alternatives exist:
- a) $\bigcup_{W_F^S \in \mathcal{F}} \mathcal{C}(W_F^S) \equiv \mathcal{C}(\mathcal{F}) = \mathcal{C}^S$ (all states tend to at least one equilibrium),
 - b) $\mathcal{C}(\mathcal{F}) \subset \mathcal{C}^S$ (some states do not approach any equilibrium).

In the case of a unique equilibrium we may expect that in certain cases W_F^S is identical with the equilibrium state W^B of the bath. So the further question arises to specify necessary and sufficient conditions for this situation.

The second case of several equilibria W_F^S with the corresponding classes $\mathcal{C}(W_F^S)$ is of some special interest. In physical terms it represents the case where the state W_t^S *conserves some memory of the initial state* throughout its motion. This implies the existence of additional constants of motion. Their physical meaning may be interesting to explore. (The occurrence of this case is related to the mathematical problem of metrical indecomposability.)

The propagators U_t^S depend on the choice of the Hamiltonian H and the initial state W^B of the bath, as one may see from their definition. It follows that in our model the sets \mathcal{F} and $\mathcal{C}(W_F^S)$ depend implicitly on H and W^B and the most general problem to be posed is that of establishing conditions on H and W^B which imply the different alternatives for \mathcal{F} and $\mathcal{C}(W_F^S)$. This problem is difficult (some indications are found in §5). We intend however to proceed in the converse direction; i. e. to start from specific Hamiltonians and bath-temperatures, and to establish the corresponding sets \mathcal{F} and $\mathcal{C}(W_F^S)$ explicitly. This procedure has the further advantage of yielding an explicit insight into the approach to equilibrium.

We shall do this for the simplest non-trivial model available, namely that of two coupled 1/2-spins. The result is astonishing in its variety: starting from three different standard coupling-schemes we obtain examples for almost all possibilities enumerated above. The explicit evolution will be visualized geometrically in the three-dimensional hypersphere \mathcal{C}^S of 1/2-spin-states.

4. Discussion of an Explicit Example

The system of two 1/2-spins is described by the direct product of two 2-dimensional Hilbert-spaces \mathcal{H}^S and \mathcal{H}^B . They evolve separately according to the free Hamiltonians H_0^S and H_0^B which may be chosen identical. In the basis in which they are diagonal we assume:

$$H_0^S = H_0^B = \begin{pmatrix} \omega + \varepsilon & 0 \\ 0 & \omega - \varepsilon \end{pmatrix}. \quad (4.1)$$

The total Hamiltonian is

$$H = H_0^S \otimes I + I \otimes H_0^B + V \equiv H_0 + V.$$

It is sufficient to discuss the interactions V vanishing on the diagonal since we may always include the diagonal part of H in H_0 . We shall in particular consider the cases

$$\begin{array}{ccc}
 \text{(I)} & \text{(II)} & \text{(III)} \\
 V = \begin{pmatrix} & & \cdot \\ & g & \\ g^* & & \end{pmatrix}; & V = \begin{pmatrix} & g & \\ & \cdot & \\ g^* & & \end{pmatrix}; & V = \begin{pmatrix} \cdot & \cdot & g & \cdot \\ & \cdot & & \\ & & g^* & \\ & & & \cdot \end{pmatrix}.
 \end{array}$$

The three other cases of this type either do not couple the two systems or are dual to (III). Note that in (I) H commutes with H_0 .

Introducing the signs \uparrow and \downarrow for the eigenstates of H_0^S resp. H_0^B (which are supposed to be equal) to the eigenvalues $\omega + \varepsilon$ and $\omega - \varepsilon$, the couplings (I) to (III) may be given the following physical meaning:

	S	B		S	B
(I) couples	\uparrow	\downarrow	to	\downarrow	\uparrow
(II)	\uparrow	\uparrow	to	\downarrow	\downarrow
(III)	\downarrow	\uparrow	to	\uparrow	\uparrow

The results will be interpreted in the 4-dimensional Liouville space \mathcal{L}^S in which we introduce the orthonormal basis

$$V_0 = \frac{1}{\sqrt{2}} \mathbf{I}; \quad V_i = \frac{1}{\sqrt{2}} \sigma_i \quad (i = 1, 2, 3).$$

Here σ_i are the Pauli matrices. Since in this basis the propagators \mathcal{U}_i^S leave the zero-component of any state vector invariant, we may restrict ourselves to the hyperplane spanned by $\{V_i\}$. The elements of this space will be designed by an arrow (for the operators we will omit them). For an arbitrary state we may thus write

$$\vec{W}^S = \sum_{i=1}^3 W_i^S V_i.$$

(Note that \mathcal{C}^S fills up the entire hypersphere $\mathcal{U} \cap \mathcal{S}$. Since in the two-dimensional case considered here the condition $\|W^S\| \leq 1$ implies the positivity of W .) Let us briefly indicate the connection between this and the Hilbertspace representation of a state as a matrix. The most general state density matrix has in \mathcal{H}^S the form

$$W^S = \begin{pmatrix} A & B \\ B^* & 1 - A \end{pmatrix}; \quad 0 \leq A \leq 1; \quad \text{Det } W \geq 0.$$

In $\mathcal{C}^S \subset \mathcal{L}^S$ this reads

$$\vec{W}^S = \sum_{i=1}^3 W_i^S V_i; \quad W_i^S = \frac{1}{\sqrt{2}} \begin{pmatrix} 2 \text{Re } B \\ -2 \text{Im } B \\ 2A - 1 \end{pmatrix}.$$

In particular W^B is supposed to be diagonal in H_0^B -representation and we obtain the correspondance

$$W^B = \begin{pmatrix} a & 0 \\ 0 & 1-a \end{pmatrix}; \quad W_i^B = \frac{1}{\sqrt{2}} \begin{pmatrix} 0 \\ 0 \\ 2a-1 \end{pmatrix}$$

where according to (2.1), (4.1)

$$a = \frac{e^{-\varepsilon/k T^B}}{e^{-\varepsilon/k T^B} + e^{\varepsilon/k T^B}}. \quad (4.2)$$

Using the calculation scheme given in § 2 we shall now determine and interpret \mathcal{U}_i^S successively for the three models (I), (II), and (III).

Model (I)

$$\mathcal{U}_{\Delta t}^S \vec{W}_0^S = \begin{pmatrix} \sqrt{\alpha} \cos \varepsilon \Delta t & -\sqrt{\alpha} \sin \varepsilon \Delta t & 0 \\ \sqrt{\alpha} \sin \varepsilon \Delta t & \sqrt{\alpha} \cos \varepsilon \Delta t & 0 \\ 0 & 0 & \alpha \end{pmatrix} \vec{W}_0^S + (1-\alpha) \vec{W}^B \quad [\alpha \equiv \cos^2 |g| \Delta t] \quad (4.3a)$$

\mathcal{U}_i^S consists of a homogeneous and an inhomogeneous part. The homogeneous part effectuates a rotation by an angle $\varepsilon \Delta t$ and a contraction by a factor $\sqrt{\alpha} < 1$ in the 1-2-plane, and it contracts the third component by $\alpha < 1$. The inhomogeneous part adds a fraction $1 - \alpha$ of the state W^B . Using the summation formula for finite geometrical sums we find now

$$\mathcal{U}_{n \Delta t}^S \vec{W}_0^S = (\mathcal{U}_{\Delta t}^S)^n \vec{W}_0^S = \begin{pmatrix} \sqrt{\alpha}^n \cos n \varepsilon \Delta t & -\sqrt{\alpha}^n \sin n \varepsilon \Delta t & 0 \\ \sqrt{\alpha}^n \sin n \varepsilon \Delta t & \sqrt{\alpha}^n \cos n \varepsilon \Delta t & 0 \\ 0 & 0 & \alpha^n \end{pmatrix} \vec{W}_0^S + (1-\alpha^n) \vec{W}^B \quad (4.3b)$$

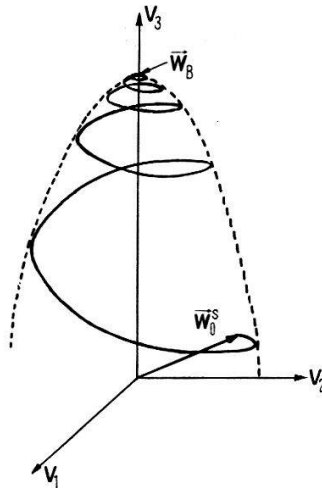

Fig. 2

The evolution of a state \mathcal{W}_0^S towards its equilibrium \mathcal{W}^B in model (I)

furthermore

$$\mathbf{u}_t^S \vec{\mathbf{W}}_0^S = (\mathbf{u}_{\Delta t}^S)^{t/\Delta t} \vec{\mathbf{W}}_0^S; \quad \lim_{t \rightarrow \infty} \mathbf{u}_t^S \vec{\mathbf{W}}_0^S \equiv \mathbf{u}_\infty^S \vec{\mathbf{W}}_0^S \equiv \vec{\mathbf{W}}_\infty^S = \vec{\mathbf{W}}^B, \quad (4.3c)$$

\mathbf{W}^B is a fixpoint of \mathbf{u}_t^S which is approached by any arbitrary initial state \mathbf{W}_0^S . There exists thus a unique equilibrium which equals that of the bath, and the class $\mathbf{C}(\mathbf{W}^B)$ is the ensemble \mathbf{C}^S of all states in \mathbf{L}^S . It may also be shown that the approach to equilibrium is uniform in time in the sense that the distance $\|\vec{\mathbf{W}}_t^S - \vec{\mathbf{W}}_\infty^S\|$ decreases monotonically. The "worldline" of an arbitrary initial state is represented in Fig. 2 (omitting the zero-component).

It is interesting to discuss this model in the light of a relaxation process. We may in fact – as indicated in Fig. 2 – introduce two relaxation times T_1 and T_2 , the first for the 3-component, the second for the length of the 1–2-component of the vector $(\vec{\mathbf{W}}_t^S - \vec{\mathbf{W}}_0^S)$. The formal definitions are thus

$$(\vec{\mathbf{W}}_{T_1}^S - \mathbf{W}_\infty^S)_3 = \frac{1}{e} (\vec{\mathbf{W}}_0^S - \mathbf{W}_\infty^S)_3$$

$$\sqrt{(\vec{\mathbf{W}}_{T_2}^S - \mathbf{W}_\infty^S)_1^2 + (\vec{\mathbf{W}}_{T_2}^S - \mathbf{W}_\infty^S)_2^2} = \frac{1}{e} \sqrt{(\vec{\mathbf{W}}_0^S - \mathbf{W}_\infty^S)_1^2 + (\vec{\mathbf{W}}_0^S - \mathbf{W}_\infty^S)_2^2}.$$

Using the expansions

$$\alpha = 1 - |g|^2 \Delta t^2 + \dots; \quad \ln \alpha = - |g|^2 \Delta t^2 + \dots$$

we find from (4.8b), (4.8c),

$$T_1 = \frac{1}{|g|^2 \Delta t}; \quad T_2 = \frac{2}{|g|^2 \Delta t}.$$

As a first conclusion, we remark $T_1 < T_2$ ⁶⁾ (this has been indicated in Fig. 2). But it is more interesting to see what T_1 and T_2 have in common:

- (a) they are independent of the initial state,
- (b) they tend to infinity for $\Delta t \rightarrow 0$.

The property (a) expresses the fact, that the rapidity of decay of \mathbf{W}^S increases with its distance from the equilibrium; this is a consequence of the exponential decay laws $\sqrt{\alpha^t}$ resp. α^t in (4.3) where the first derivative is proportional to the size of the function itself. Property (b) has the following physical meaning: In order to maintain the law of approach to equilibrium fixed for a collision whose duration Δt tends to zero, it is necessary to keep the product $|g|^2 \Delta t$ constant: for decreasing Δt the coupling strength $|g|^2$ must increase.

⁶⁾ The existence of two relaxing processes of the type described here is well known in the theory of magnetic resonance. The time T_1 describes the approach to the equilibrium population and corresponds to the so called spin-lattice relaxation. The time T_2 , deals with the annihilation of the off-diagonal elements of the density matrix and corresponds to the spin-spin relaxation. The experiment shows that $T_1 \geq T_2$ which contradicts our result. This however means simply that the Heisenberg interaction we used (see last remark of § 4) is not the only source responsible for the relaxation in these experiments. For further details see for instance A. ABRAGAM: *The principles of nuclear magnetism* (Oxford at the Clarendon Press, 1961).

Model (II)

$$\mathbf{u}_{\Delta t}^S \vec{W}_0^S = \begin{pmatrix} \sqrt{\alpha} & \sqrt{1-\beta} \sqrt{1-\alpha} & 0 \\ -\sqrt{1-\beta} \sqrt{1-\alpha} & \sqrt{\alpha} & 0 \\ 0 & 0 & 1-\beta(1-\alpha) \end{pmatrix} \vec{W}_0^S - \beta(1-\alpha) \vec{W}^B$$

$$\left[\alpha \equiv \cos^2 \sqrt{|g|^2 + \varepsilon^2} \Delta t; \quad \beta \equiv \frac{4(\varepsilon + \sqrt{|g|^2 + \varepsilon^2})^2 |g|^2}{((\varepsilon + \sqrt{|g|^2 + \varepsilon^2})^2 + |g|^2)^2} \right].$$

The situation looks here very similar to that of the model (I). A slight complication consisting in the existence of constants depending both on $|g|$ and ε is due to the fact that H does not commute here with H_0 and mixes up states of H_0 -energy $(\omega + \varepsilon)$ and $(\omega - \varepsilon)$. (If we set $\varepsilon = 0$ we remark in fact, that $\beta = 1$ and $\alpha = \cos^2 |g| \Delta t$, and we obtain the same constants as in (I)).

There is however one essential difference between (I) and (II): *in (II) the unique equilibrium of the system S is not \vec{W}^B , but \vec{W}^B with inversed populations:*

$$\vec{W}_\infty^S = -\vec{W}^B.$$

If T^B is the temperature of \mathbf{W}^B according to (4.2), the equilibrium state \mathbf{W}_∞^S has temperature $-T^B$ (remember that we assumed $H_0^S = H_0^B$). This fact should not astonish here, since in the two-particle subspace, in which collisions take place, the total energy is not conserved. One should always maintain the picture of collision with an infinite bath; at any time t which is a multiple of Δt one particle of the bath is replaced by another, which produces an obvious jump in the energy of the two-particle "collision subspace".

Model (III)

$$\mathbf{u}_{\Delta t}^S = \begin{pmatrix} 1 - 2a(1-\alpha)(1-\beta \cos^2 \theta) & 2a\sqrt{\alpha(1-\alpha)(1-\beta)} & 2a(1-\alpha)\sqrt{\beta(1-\beta)} \cos \theta \\ -2a\sqrt{\alpha(1-\alpha)(1-\beta)} & 1 - 2a(1-\alpha)(1-\beta \sin^2 \theta) & +2a\sqrt{\alpha\beta(1-\alpha)} \sin \theta \\ -a\beta(1-\alpha) \sin 2\theta & & -2a(1-\alpha)\sqrt{\beta(1-\beta)} \sin \theta \\ 2a(1-\alpha)\sqrt{\beta(1-\beta)} \cos \theta & -2a\sqrt{\alpha\beta(1-\alpha)} \cos \theta & 1 - 2\alpha\beta(1-\alpha) \\ -2a\sqrt{\alpha\beta(1-\alpha)} \sin \theta & -2a(1-\alpha)\sqrt{\beta(1-\beta)} \sin \theta & \end{pmatrix}$$

$$\left[\alpha \equiv \cos^2 \sqrt{|g|^2 + (\varepsilon/2)^2} \Delta t; \quad \beta \equiv \frac{4g^2(\varepsilon/2 - \sqrt{|g|^2 + (\varepsilon/2)^2})^2}{(\varepsilon/2 - \sqrt{(\varepsilon/2)^2 + |g|^2 + |g|^2})^2}; \quad \theta \equiv \arctg \frac{\text{Im } g}{\text{Re } g} \right]. \quad (4.4)$$

We notice here an obvious difference between the models (I) and (II) in the fact that $\mathbf{u}_{\Delta t}^S$ is homogeneous and that the information contained in \mathbf{W}^B acts in a different manner: we cannot expect \mathbf{W}^B to be an equilibrium in this model. Let us now parametrize the above motion in a way which is suitable for geometrical interpretation.

Consider in the three-dimensional sphere \mathcal{C}^S a rotation $R(\varphi, \vec{n})$ by an angle φ leaving the axis $\vec{n} = \sum_i n_i V_i$ invariant. In components this may be written (with summation rule):

$$R_{ik} W_k^S = (\cos\varphi \delta_{ik} + (1 - \cos\varphi) n_i n_k + \sin\varphi \varepsilon_{ikl} n_l) W_k^S.$$

We claim now that $\mathcal{U}_{\Delta t}^S$ is of the form

$$\mathcal{U}_{\Delta t}^S = a R(\varphi, \vec{n}) + (1 - a) \cdot I$$

or, in components

$$(\mathcal{U}_{\Delta t}^S)_{ik} = \delta_{ik} + a(1 - \cos\varphi) (n_i n_k - \delta_{ik}) + a \sin\varphi \varepsilon_{ikl} n_l. \tag{4.5}$$

In order to prove this we have only to choose

$$\varphi = 2 \sqrt{|g|^2 + (\varepsilon/2)^2} \Delta t; \quad \vec{n} = \begin{pmatrix} -\sqrt{\beta} \cdot \cos\theta \\ \sqrt{\beta} \cdot \sin\theta \\ -\sqrt{1 - \beta} \end{pmatrix}.$$

From this follows at once

$$\cos\varphi = 2\alpha - 1, \quad 1 - \cos\varphi = 2(1 - \alpha), \quad \sin\varphi = 2\sqrt{\alpha(1 - \alpha)}$$

and we may identify (4.4) and (4.5). For $0 < a < 1$ we conclude that $\mathcal{U}_{\Delta t}^S$ leaves exactly the axis \vec{n} invariant, i.e. $\mathcal{F} = \{\lambda \vec{n}\}$, and that all initial states W_0^S converge to a point of the axis, i.e. $\mathcal{C}(\mathcal{F}) = \mathcal{C}^S$. In the special case $a = 0$, (4.2) implies that bath-temperature $T^B = +0$ ($-1/T^B = -\infty$); then all points of \mathcal{C}^S are fix, i.e. $\mathcal{F} = \mathcal{C}^S$; in the other extreme case $a = 1$ ((4.2) $\triangleright T^B = -0$) the axis \vec{n} is invariant but no other states tend to these equilibria, i.e. $\mathcal{F} = \{\lambda \vec{n}\}$, $\mathcal{C}(\mathcal{F}) = \mathcal{F} \neq \mathcal{C}^S$.

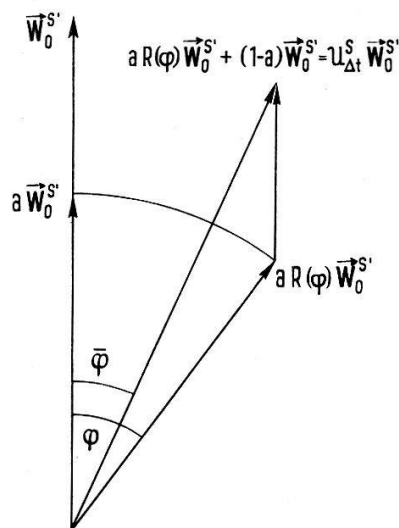

Fig. 3

Construction of state W_i^S out of the state W_0^S in model (III)

Let us first split the initial state \vec{W}_0^S into a component parallel and one orthogonal to \vec{n}

$$\vec{W}_0^S = (\vec{n}, \vec{W}_0^S) \vec{n} + \vec{W}_0^{S'}$$

The first component is left invariant under $\mathcal{U}_{\Delta t}^S$ and it suffices to discuss the movement of the second in the two-dimensional plane orthogonal to \vec{n} (Fig. 3).

Call $\bar{\varphi}$ the angle by which $\vec{W}_0^{S'}$ has rotated and γ the factor by which it has been contracted under the action of $\mathcal{U}_{\Delta t}^S$. They may be expressed as follows by a and φ (resp. α):

$$\cos \bar{\varphi} = \frac{1 - a(1 - \cos \varphi)}{\sqrt{1 - 2a(1 - a)(1 - \cos \varphi)}} = \frac{1 - 2a(1 - \alpha)}{\sqrt{1 - 4a(1 - a)(1 - \alpha)}}$$

$$\gamma = \sqrt{1 - 2a(1 - a)(1 - \cos \varphi)} = \sqrt{1 - 4a(1 - a)(1 - \alpha)}$$

It is now immediately seen that $\bar{\varphi} \neq 0$, except in the case $a = 0$ ($T^B = +0$); in this case $\vec{W}_0^{S'}$ and thus \vec{W}_0^S do not move and all states in \mathcal{C}^S remain fixed. On the other hand, for $a \neq 0$: $\gamma < 1$ whenever $a \neq 1$, and any initial state $\vec{W}_0^{S'}$ moves towards zero in a spiral with a speed which depends on a and Δt (Fig. 4).

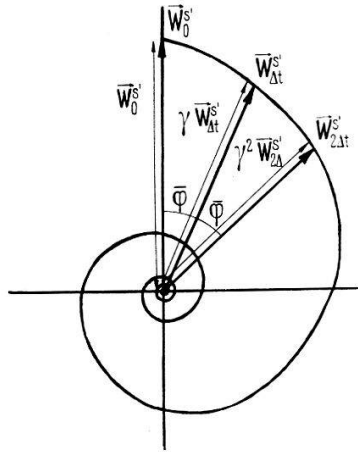

Fig. 4

The evolution of the projection $\vec{W}_0^{S'}$ of a state \vec{W}_0^S into the plane defined by $(\vec{n}, \vec{W}_t^S) = (\vec{n}, \vec{W}_0^S)$ in model (III)

In the limiting case, finally, where $a = 1$ (temperature of the bath-0), $\gamma = 1$ and all states move in circles never approaching the axis \vec{n} . Here we have the case of the existence of states in \mathcal{C}^S which never approach an equilibrium ($\mathcal{C}(\mathcal{F}) \subset \mathcal{C}^S$).

In order to discuss the physical meaning of a system with non-unique equilibrium, let us write down the general equation of motion for \vec{W}_t^S :

$$\mathcal{U}^S \vec{W}_0^S = (\vec{n}, \vec{W}_0^S) \vec{n} + \gamma^{t/\Delta t} R(\bar{\varphi} t/\Delta t) \vec{W}_0^{S'}$$

This leads (with $\bar{\varphi} \neq 0; \gamma < 1$) to the equilibria

$$\begin{aligned} \lim_{t \rightarrow \infty} \mathbf{u}_i^S \vec{W}_0^S &= \vec{W}_\infty^S = (\vec{n}, \vec{W}_0^S) \vec{n} \\ &= -W_1 \sqrt{\beta} \cos \theta \cdot \mathbf{V}_1 + W_2 \sqrt{\beta} \sin \theta \cdot \mathbf{V}_2 + W_3 \sqrt{1 - \beta} \mathbf{V}_3 \end{aligned}$$

where $W_1, W_2,$ and W_3 are the components of the initial state. We see that

- (a) some information about the initial state is carried throughout all times; *the system does not entirely lose its memory*;
- (b) *the initial state W^B of the bath does not influence the equilibrium states of the system S ; it influences however the speed by which they are approached.*

Let us put together the main results for the different cases (I), (II), (III) in the short-hand notation introduced in § 3:

- (I) $\mathcal{F} = \{W^B\}; \quad C(W^B) = C(\mathcal{F}) = C^S$
- (II) $\mathcal{F} = \{-W^B\}; \quad C(-W^B) = C(\mathcal{F}) = C.$
- (III) $\left\{ \begin{array}{l} \text{(a) } T^B = +0 \text{ } (-1/T^B = -\infty): \mathcal{F} = C(\mathcal{F}) = C^S \\ \text{(b) } +0 < T^B < -0 \text{ } (-\infty < -1/T^B < +\infty): \\ \mathcal{F} = \text{axis } \vec{n}; \text{ let } \lambda \vec{n} \text{ denote an arbitrary point of this axis; then } C(\lambda \vec{n}) = \\ \text{plane orthogonal to } \vec{n} \text{ through } \lambda \vec{n} \text{ and } \bigcup_{\lambda} C(\lambda \vec{n}) = C(\mathcal{F}) = C^S, \\ \text{(c) } T^B = -0 \text{ } (-1/T^B = +\infty): \mathcal{F} = \text{axis } \vec{n}; C(\lambda \vec{n}) = \text{point } \lambda \vec{n}; C(\mathcal{F}) \subset C^S. \end{array} \right.$

The scale $(-1/T)$ is the scale used in general for spin-temperature.

It is interesting to note that the model (I) which seems to behave more physically than the others differs from the wellknown HEISENBERG interaction

$$V = \sigma_1 \otimes \sigma_1 + \sigma_2 \otimes \sigma_2 + \sigma_3 \otimes \sigma_3$$

only by the diagonal term in σ_3 , which however does not affect the evolution of the system.

5. Various Other Remarks

In this section we shall make some additional general remarks in connection with our models.

(1) Entropy of the system S

The entropy of a state W may be defined in Liouville space \mathcal{L} by

$$S = -\ln || W ||^2.$$

If we choose in \mathfrak{L} the particular basis in which all states have equal zero-components C_0 this reads

$$S = - \ln (|| \vec{\mathbf{W}} ||^2 + C_0^2)$$

where $\vec{\mathbf{W}}$ denotes the component of \mathbf{W} orthogonal to \mathbf{V}_0 . The state of maximal entropy is thus

$$\vec{\mathbf{W}} = 0 .$$

In the models which we have studied in § 4 the equilibrium state of S does not, in general, correspond to the state of maximal entropy. While for the coupling (III) the length of \mathbf{W}_t^S decreases and hence the entropy increases monotonously in time, this is not true for the cases (I) and (II). For (II), for instance, any state tends to the equilibrium $\vec{\mathbf{W}}_\infty^S = - \vec{\mathbf{W}}^B$. If we choose, in particular, $\vec{\mathbf{W}}^B$ for the initial state, the initial and final entropies coincide, while $\vec{\mathbf{W}}_t$ passes through the state $\vec{\mathbf{W}} = 0$ of maximal entropy at an intermediate time t' ; for this case the function $S(t)$ is thus not monotonous.

(This is however not astonishing, since the system S is not insulated.)

(2) *The case of commuting H_0 and V*

We find that H_0 and V commute in the spin model (I). The same would be true for models (II) and (III) if we set $\varepsilon = 0$. Considering now the propagators $\mathbf{u}_{\Delta t}^S$ in these models we remark that the assumption $\varepsilon = 0$ modifies only the constants α and β :

$$\varepsilon = 0 \quad \triangleright \quad \alpha = \cos^2 |g| \Delta t; \quad \beta = 1$$

and we conclude that the postulate of commuting H_0 and V does not essentially affect the structure of the equilibrium problems in our model.

(3) *The limit of short collisions*

If the duration of the successive collisions tends to zero, the evolution is defined by

$$\mathbf{u}_t^S = \lim_{\Delta t \rightarrow 0} (\mathbf{u}_{\Delta t}^S)^{t/\Delta t} .$$

The equilibrium problem is then essentially changed in the spin models (I) and (II). One shows that in these cases \mathbf{u}_t^S induces a rotation (with speed ε) round the axis \mathbf{V}_3 and we find

$$\mathbf{C}(\mathfrak{F}) = \mathfrak{F} = \text{axis } \mathbf{V}_3 .$$

In model (III) the general results enounced at the end of § 4 remain unchanged.

(4) *Markofficity*

Consider the two projectors P_1 and P_2 in \mathfrak{H}^S projecting respectively on the orthogonal states

$$\varphi_1 = \begin{pmatrix} 1 \\ 0 \end{pmatrix}; \quad \varphi_2 = \begin{pmatrix} 0 \\ 1 \end{pmatrix}$$

in \mathcal{H}^S . In \mathcal{L} these operators are represented by the orthonormal elements

$$\mathbf{P}_1 = \frac{1}{\sqrt{2}} (\mathbf{V}_0 + \mathbf{V}_3); \quad \mathbf{P}_2 = \frac{1}{\sqrt{2}} (\mathbf{V}_0 - \mathbf{V}_3). \quad (5.1)$$

Furthermore

$$\mathbf{P}_1 + \mathbf{P}_2 = \mathbf{I}.$$

They may thus be considered as a set of independent events. A sufficient condition for the validity of the corresponding CHAPMAN-KOLMOGOROFF equation [3]

$$(\mathbf{P}_i, \mathcal{U}_{t_1+t_2}^S \mathbf{P}_k) = \sum_l (\mathbf{P}_i, \mathcal{U}_{t_2}^S \mathbf{P}_l) (\mathbf{P}_l, \mathcal{U}_{t_1}^S \mathbf{P}_k)$$

(which in turn expresses the Markofficity of the process [4]) is that the propagators \mathcal{U}_i^S map the subspace of \mathbf{Y} spanned by \mathbf{P}_1 and \mathbf{P}_2 (and its orthogonal complement) into itself. It is easily seen from the general forms of \mathcal{U}_i^S given in §4, that this is the case for the models (I) and (II) (but not for (III)). On the other hand we know that the elements \mathbf{V}_0 and \mathbf{V}_3 , and thus also \mathbf{P}_1 and \mathbf{P}_2 span the set of all diagonal matrices in \mathcal{H}^S and we may state the result: *if the evolution $\{\mathcal{U}_i^S\}$ does not mix up the diagonal and non-diagonal parts of the statematrices, then it is a (homogeneous) Markov process with respect to the events \mathbf{P}_i defined in (5.1).*

6. Physical Improvement of the Model

The model as stated so far gave us some insight on the approach of quantum systems to equilibrium. Let us now raise the question to what extent these models mirror some real physical situations. Given a very big bath B of identical particles in thermal equilibrium. We introduce another particle S "of interest" into the bath, which collides successively with particles of B ; the probability of a second collision of S with the same particle of B is supposed to vanish (infiniteness of B). Let i denote the ordinal number of the collisions, Δt_i the duration of the i -th collision, $\Delta \tau_i$ the interval between the beginning of the i -th and the $(i+1)$ -th collision. So far we considered

$$\Delta t_i \equiv \Delta \tau_i \equiv \Delta t = \text{const.}$$

In the most general situation Δt_i and $(\Delta \tau_i - \Delta t_i)$ would be distributed according to independent Poisson distributions. This case will not be discussed here, the only generalisation we shall discuss is

$$\Delta t_i \equiv \Delta t; \quad \Delta \tau_i \equiv \Delta \tau > \Delta t \quad (\text{short collisions}).$$

One expects, that this modification should not change the sets \mathcal{F} of equilibria themselves but rather the laws of approach to equilibrium (relaxation times). This is however not exactly true because of the proper evolution H_0 of the systems.

So, for instance, in the spin model, case (III). The calculation shows that the set \mathcal{F} will reduce to the point $\vec{W} = 0$. We conclude that here *the insertion of a free path between the collisions destroys the memory of the initial state*. The reason is the following: during the collision the state rotates round an axis \vec{n} , its \vec{n} -component being invariant.

In the intervals between two collisions, however, a rotation takes place round the axis \mathbf{V}_3 (speed $\varepsilon/\Delta t$), which is not parallel to $\vec{\mathbf{n}}$. But any vector submitted to alternative rotations round non commuting axes reduces to zero.

The effect of the above generalization in the cases (I), and (II), of the spin-example is much more trivial: it results simply in a modification of the relaxation times T_1 and T_2 , which now read:

$$T_1 = \frac{\Delta\tau}{|g|^2 \Delta t^2}; \quad T_2 = \frac{2 \Delta\tau}{|g|^2 \Delta t^2}.$$

7. Conclusion

We have studied irreversible quantum processes by means of a definite model. The main result is that the behaviour of the system is very strongly dependent on the interaction. Considering in detail some of the simplest couplings we observed that almost all thinkable ways of approach or non approach to equilibrium were realized. Our results may thus furnish some background to a more general study of the equilibrium question. They indicate that general theorems are to be expected only under rather restrictive assumptions on the form of the interactions.

Acknowledgment

We thank Prof. J. M. JAUCH for his kind encouragement and suggestive criticism.

References

- [1] N. DUNFORD and J. T. SCHWARTZ, *Linear Operators, Part I: General Theory*, Interscience Publishers, New York, London (1958), p. 456.
- [2] G. LUDWIG in Proc. Intern. School of Physics ENRICO FERMI XIV Course (Acad. Press New York and London 1961), p. 57. The detail is given in Theorem 10.
- [3] LAJOS TAKACS, *Stochastic Processes* (Methuen's Monographs on Applied Statistics).
- [4] G. EMCH, *Helv. phys. Acta* 37, 532 (1964).