

Modal analysis in practice

Autor(en): **Peters, J. / Snoeys, R. / Noortgate, L. van den**

Objektyp: **Article**

Zeitschrift: **Schweizer Ingenieur und Architekt**

Band (Jahr): **101 (1983)**

Heft 15

PDF erstellt am: **08.08.2024**

Persistenter Link: <https://doi.org/10.5169/seals-75113>

Nutzungsbedingungen

Die ETH-Bibliothek ist Anbieterin der digitalisierten Zeitschriften. Sie besitzt keine Urheberrechte an den Inhalten der Zeitschriften. Die Rechte liegen in der Regel bei den Herausgebern.

Die auf der Plattform e-periodica veröffentlichten Dokumente stehen für nicht-kommerzielle Zwecke in Lehre und Forschung sowie für die private Nutzung frei zur Verfügung. Einzelne Dateien oder Ausdrucke aus diesem Angebot können zusammen mit diesen Nutzungsbedingungen und den korrekten Herkunftsbezeichnungen weitergegeben werden.

Das Veröffentlichen von Bildern in Print- und Online-Publikationen ist nur mit vorheriger Genehmigung der Rechteinhaber erlaubt. Die systematische Speicherung von Teilen des elektronischen Angebots auf anderen Servern bedarf ebenfalls des schriftlichen Einverständnisses der Rechteinhaber.

Haftungsausschluss

Alle Angaben erfolgen ohne Gewähr für Vollständigkeit oder Richtigkeit. Es wird keine Haftung übernommen für Schäden durch die Verwendung von Informationen aus diesem Online-Angebot oder durch das Fehlen von Informationen. Dies gilt auch für Inhalte Dritter, die über dieses Angebot zugänglich sind.

Thesen: Notwendige Verbindung zwischen geistiger Kreativität und wirtschaftlichem Fortschritt

Ich möchte meinen Gedankengang in vier Schlussthesen zusammenfassen:

Zwischen Freiheit des Geistes und Sachzwängen der Wirtschaft besteht ein enger Zusammenhang, weil der wirtschaftliche Fortschritt ohne freie geistige Impulse gar nicht denkbar ist. Der Raum für das Schöpferische kann nie gross genug sein. Dies gilt vornehmlich für die Schweiz, die sich auf dem schrumpfenden Weltmarkt mit Spitzentechnologie zu behaupten hat. Gerade heute ist evident, dass Stagnation und Arbeitslosigkeit nur durch Innovationsgeist und Strukturerneuerung überwunden werden können.

Die wirtschaftlichen Eigengesetzlichkeiten müssen berücksichtigt werden, weil die Wirtschaft sonst nicht funktioniert. Dies heisst aber nicht, dass Ziel-

konflikte immer automatisch zugunsten der Wirtschaft und zu Lasten des Ideellen zu lösen sind. Es gibt in der Regel einen Ermessensspielraum, der bei richtiger Abwägung der Interessen einen Ausgleich ermöglicht.

Die Beschränkung des Staates auf das Setzen freiheitlicher Rahmenbedingungen, innerhalb deren sich die Wirtschaftstätigkeit nach ihren Gesetzmässigkeiten entfalten kann, überlässt das Feld für die Umsetzung geistiger Erkenntnisse in wirtschaftlichen Fortschritt der unternehmerischen Initiative; nicht nur im kommerziellen, sondern zum Teil auch im sozialen Sinne. Hier tritt aber der Staat auf den Plan. Er hat unliebsame Auswirkungen auf andere Erwerbsgruppen oder die Allgemeinheit sowie auf ausländische Wirtschaftspartner zu vermeiden. Seine Aufgabe ist es, für eine möglichst hohe Kongruenz der wirtschafts- und sozialpolitischen, der nationalen und internationalen Ziele zu sorgen.

Die Hochschule leistet mit der Förderung des Schöpferischen und der Stärkung der freien Urteilsfähigkeit einen wichtigen Beitrag. Sie muss den Blick für die Grenzen des Wirtschaftswachstums, der Belastbarkeit der Umwelt und den sparsamen Umgang mit den verfügbaren natürlichen Ressourcen schärfen. Sie schafft damit die geistige Voraussetzung für eine harmonische und spannungsfreie Wirtschaftsentwicklung und Gesellschaftsordnung. Ohne Humanismus gäbe es keine Gegenposition zur Wirtschaft, womit wir wieder bei Max Frisch und Tinguely angelangt sind. Und dazu soll das jetzt in Zürich gezeigte «Gesamtkunstwerk» den Glauben in die kulturelle Schöpfungskraft Europas bestärken helfen!

Adresse des Verfassers: Staatssekretär Dr. P. R. Jolles, Direktor des Bundesamtes für Aussenwirtschaft, 3003 Bern.

Angewandte Mechanik in Industrie und Hochschule V*

Modal Analysis in Practice

By J. Peters, Leuven, R. Snoeys, Leuven, and L. Van den Noortgate, Heverlee

L'analyse modale fait partie de l'ensemble de ce qu'on appelle analyse dynamique. C'est une méthode rapide et pratique qui permet de faire ce qu'on appelle jadis il fallait effectuer par une analyse point par point. Le diagramme de Campbell, le diagramme d'ordre procurent une signature du phénomène riche en renseignements, à partir de laquelle on peut se baser pour effectuer une analyse modale, suivie d'une étude de la sensibilité de l'objet à une modification quelconque.

Quatre exemples sont traités: une presse à extrusion de polymères, une foreuse de précision, les vibrations d'un plateau en béton dû au placement d'un compresseur supplémentaire.

In a first part the principle of modal analysis will be explained for engineers working in industry. The problems of "windowing", digitizing, curve fitting will be briefly mentioned as well as those of excitation methods.

A survey of industrial applications will be given in different industrial fields; automotive power, machine tools, space ... Problems of sensitivity analysis will be considered with application to design.

Perspects for future application in the field of maintenance and failure prediction will be discussed. The problems of noise emission will be related. Implication to engineering education will be considered!

The subject of modal analysis in practice is one of the most convincing examples in the frame of this symposium. Close cooperation between university, instrument builders and industrial firms has produced a completely new

approach to design, maintenance, safety problems, comfort and material research.

Two centuries ago, the celebrated J. B. Fourier would never have anticipated that his obtruse theory would produce such a large number of practical applications. Thirty years ago, when we graduated from university, the notion of modal shape, modal parameters, ortho-

gonality of modes, curve fitting belonged to the nightmare of examination stuff to be forgotten. Standing waves of vibrating strings and Chnaldi figures on disks were the only experimental evidence to visualize the theory.

Today the *visual representation* of ten to twenty modal shapes on a screen is still a shocking image for designer who is only used to statical concepts [1, 2].

Engineering consulting firms are earning their living applying modal methods, we quote SDR, LMS, RMS, as well as university and industrial centers as CRIF, Univ. of Cincinnati, T. H. Aachen, K. U. Leuven, ETH Zürich and others.

New Concepts Introduced by Dynamic Analysis

The power of *dynamic* analysis, say modal analysis, versus mere *statical* study has not yet been fully understood by the designers. The *advantages* are:

- Dynamic excitation at resonant frequency provides a large displacement vs force ratio and makes deformation modes to appear whereas statical tests must assume deformation modes;
- dynamic measurement techniques provide a seismic stable reference which is much less sensitive to zero-shift;

* Vgl. Schweizer Ingenieur und Architekt, Heft 51/52: 1117-1121, 1982; Heft 1/2: 2-7; Heft 4: 42-46, 47-50; Heft 9: 275-278, 279-281; Heft 15: 413-416, 1983.

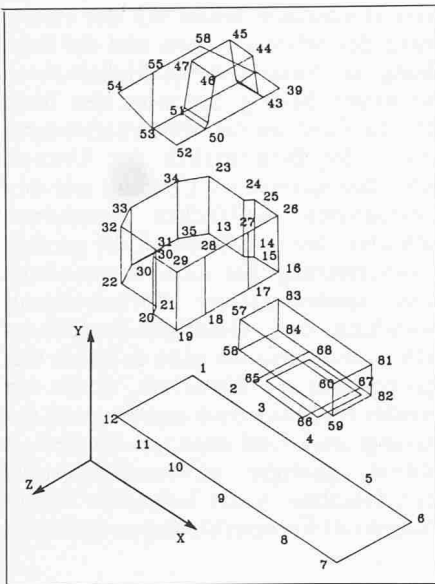

Fig. 1. Exploded view of an extrusion press

– finally, for the designer, dynamic analysis has brought forward the notion of damping in the design. Until about 20 years ago all effort in design was concentrated into increasing the stiffness. Indeed statically an increase of stiffness decreases the deformation, but dynamically it merely shifts the resonance frequency provided it can be done without increasing the mass, but once at resonance the only way to limit the deformation is to increase the damping. Hence the numerous studies recently devoted to means for damping structure.

Very recent methods based on sensitivity analysis using Fourier Analysis put a powerful tool in the hands.

Modal Analysis as a Part of the Package

Modal analysis is only a convenient method for tackling dynamic analysis problems in a fast and practical way. But

often an exaggerated interest for computer programming and finite element synthesis makes people to forget that finally modal analysis is nothing else but a search of natural frequencies and of the associated deformation “modes”. It was started 30 years ago when a whole frequency range was swept frequency by frequency to find the resonance peaks and then on every peak the displacements on selected points.

The deformations (*modal shapes*) were drafted manually point by point. The use of *Fast Fourier Transform* upon different kinds of excitation, appropriate filtering techniques, analog to digital transformation and computerized curve fitting techniques have made “dynamic analysis” to what it is now “modal analysis”, which provides animated modal images on a screen after the structure has been excited with a signal containing the required frequencies.

Let us however not forget that techniques as *Campbell diagram*, order ratio diagrams, frequency scan are still powerful means to be considered as complements to modal analysis.

Let us give a few examples from practice in which modal analysis has produced major improvements either to the structural behavior, either to the acoustic emission.

Some Applications

An extrusion press for plastic material

A prototype *press* was studied in order to improve its *vibrational behavior* assuming it would not be anchored to the floor. Figure 1 give an exploded view is given of the different parts with the numbered points, figures 2 and 3 gives resp. the Campbell and the order ratio diagrams.

As well known the Campbell diagram provides a series of amplitude vs frequency response curves when the driving motor is rotating at different speeds from 80–400 rpm. The natural frequencies are always located at a frequency which is independent from the rotational frequency. They will appear on a straight vertical line at the resonance frequency itself. The excitation frequencies and their harmonics are on oblique lines through the origin because the ratio between frequency and rotational frequency is constant. This is called “order ratio”. The previous curves are converted into “order ratio diagram” deviding the frequencies by the considered rotational frequency so that forced frequency peaks previously on oblique lines appear on vertical lines vs the considered order ratio. The resonance peaks previously on vertical lines are now on hyperbolae. It is even possible by means of a summation program to make the excitation peaks appear strongly while the resonance frequencies vanish.

In this case the signature analysis (fig. 3) undoubtedly shows one vibration source coinciding with the rotational frequency of the toothed belt (2,13 Hz). The even harmonics (multiples of 4,26 Hz) dominate, corresponding with the belt contact on the motor axis and at the driven spindle.

A better selection of belts and more precise wheels produced a real improvement. Further natural frequencies around 100 Hz were observed. The modal analysis (fig. 4) made by means of an impuls excitation of 5000 N at point 24 picked up with a 3 directional accelerometer on all numbered points produced 222 transfer functions.

Fig. 4, 5 and 6 showed clearly a dominant mode at 96 Hz due to a bending of the support plate and deformation of

Fig. 2. Campbell diagram related to the extrusion press

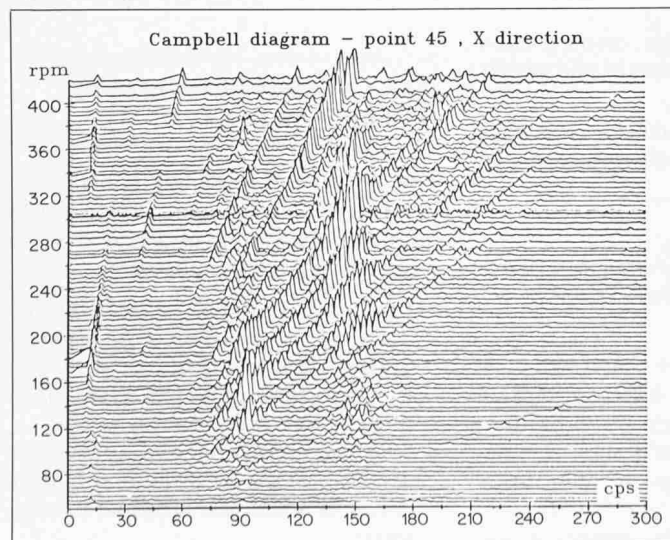
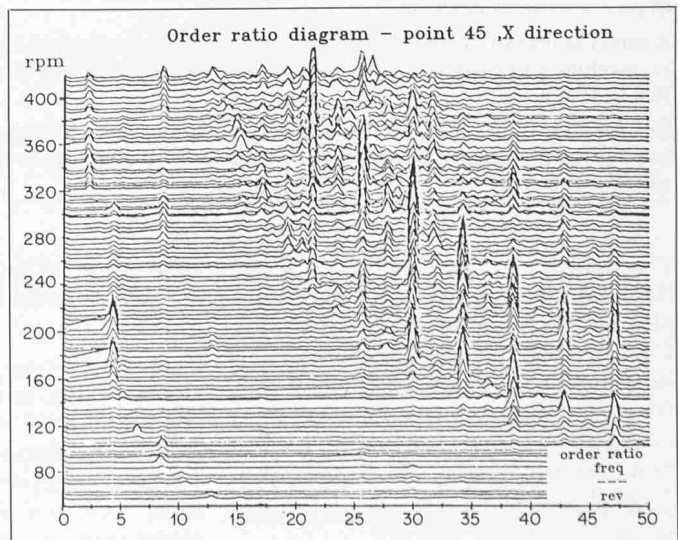

Fig. 3. Order Ratio diagram related to the extrusion press



the fixing points. The plate was redesigned and stiffened.

A long series of similar examples could be mentioned as e. g. the study of a heavy reduction box for transport machinery. Noise was generated by the coincidence of the natural frequency of a wall and gear rotation frequency. The combined use of modal analysis and signature analysis showed how the impulses due to some gear shape errors and eccentricity excited the resonant frequency of the wall, over a conical ball bearing, which produced a tight coupling between shaft and wall. Stiffening the wall, and especially replacing the conical bearing by a spherical one solved the problem.

After solving the problems it looks evident, but a previous cut and try approach did not bring a solution, and was very costly in manhours and delay on delivery.

Sensitivity Analysis

The modal analysis of a *drilling machine* gave typical modes (fig. 7) at 119 Hz, 125 Hz, 148 Hz, 160 Hz. A priori it could be suggested to introduce an tuned absorber somewhere in the structure. But two problems arise.

Is an absorber the right solution? Increasing stiffness between some points or adding a mass somewhere could also be possible solutions.

A very large number of solutions may appear when considering the different coupling points. Furthermore the solution must be an "overall" optimum, not only valid for one mode and deteriorate the behavior at the other modes. A manual check, even by an experienced person would be timeconsuming and costly.

P. Vanhonacker [3] developed a general procedure based on the use of the frequency responses. Following steps are generated:

- The main structure is experimentally tested. The response curve and the mathematical model of the structure is deduced using the technique of the adjoint structure, which describes the real structure by means of localized masses and coupling stiffeners.
- A performance function is chosen, as e. g. the overall displacement of a certain point, or the resonance frequency shift, or the maximum overall amplitudes at resonance, or a combination of those with some weighting coefficient.

The change of the performance index is computed by means of finite difference analysis, rather than merely differentiating.

In fact it all amounts to the construction of a mathematical model based on the experimental data and to introduce some changes into the model either altering mathematical parameters, either adding some elements also mathematically described as e. g. absorbers. The former method is called "parametric changes", the latter one "non parametric changes" or "system synthesis".

The results of the method applied to the drilling machine are shown in figure 8, a change of mass at point 1 resp. 10 produce following change (table 1) in damped resonance frequency.

Stiffening the guideways, respectively the vertical guideway between the drilling head (point 10) and the carriage (point 4), or the horizontal guideway between the carriage (point 60) and the column (point 31), produces following shift in natural frequency (table 2):

Both previous changes are parametric, adding a absorber is non parametric. This change will be considered in what follows.

The performance index ΔG_{11} chosen was evidently the direct compliance change in point 1, it means the displacement at the tool vs force at the tool. The computation was made for coupling the absorber in 70 different points. It appeared that coupling the absorber at point 1, 15 and 36 gave the best results. Values given below are extracted from a full table where 70 coupling points were considered.

The computing time required on a HP 1000 was smaller than the printing time of the results (table 3).

It must be noted that at some points the displacement change can be positive (increase of the order of 0.08 μm). In

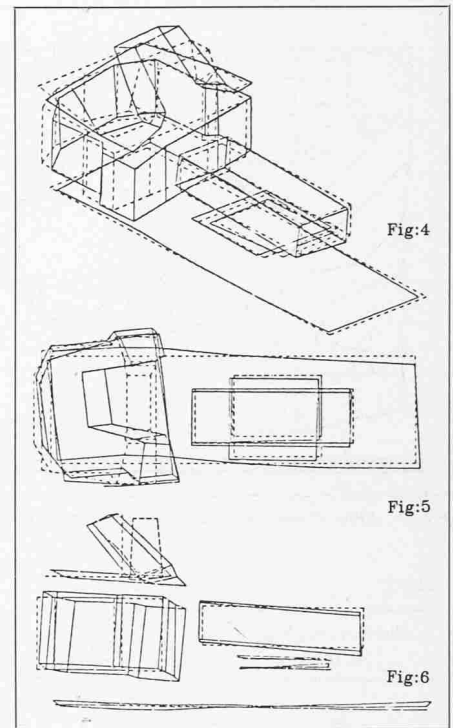

Fig. 4, 5, 6. Modal shape of the press in different planes at 96 Hz

Table 1.

Mode k	$\frac{\partial v_k}{\partial m_1}$ [Hz/kg]	$\frac{\partial v_k}{\partial m_{10}}$ [Hz/kg]
1	-0,94	0
2	-0,56	-0,19
3	-0,51	-0,50
4	-1,75	-0,06

Table 2.

Mode k	$\frac{\partial v_k}{\partial k_{4-10}}$ [Hz/N]	$\frac{\partial v_k}{\partial k_{31-60}}$ [Hz/N]
1	$6,6 \cdot 10^{-2}$	$1,5 \cdot 10^{-3}$
2	$3 \cdot 10^{-2}$	$1,7 \cdot 10^{-3}$
3	$6,4 \cdot 10^{-2}$	$7,6 \cdot 10^{-5}$
4	$4,6 \cdot 10^{-2}$	$7,7 \cdot 10^{-10}$

Fig. 7. Modal shapes at different frequencies of a vertical drilling machine

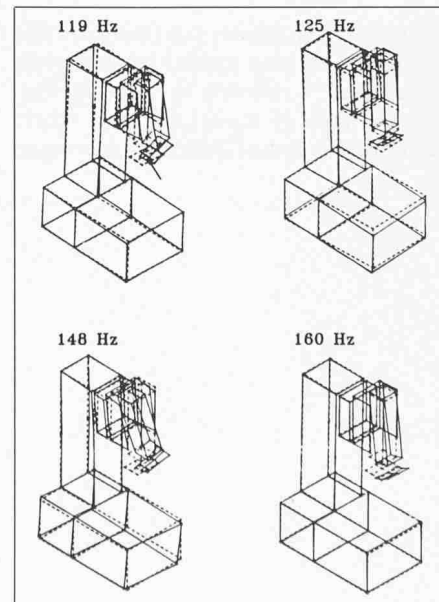
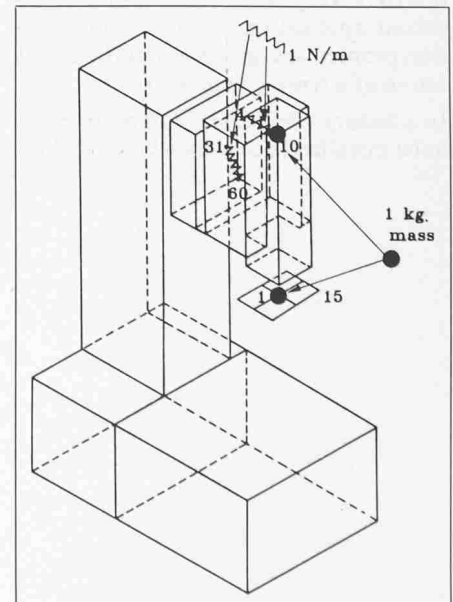

Fig. 8. Schematic view of the drilling machine



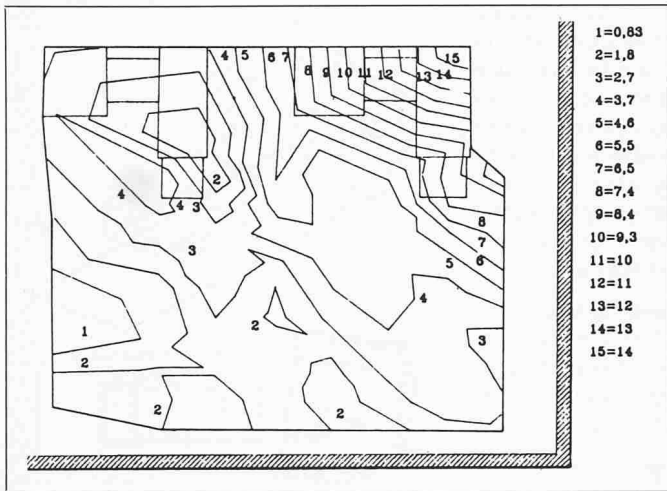

Fig. 9. Lines of equal vibratory level in a compressor room at 7 Hz

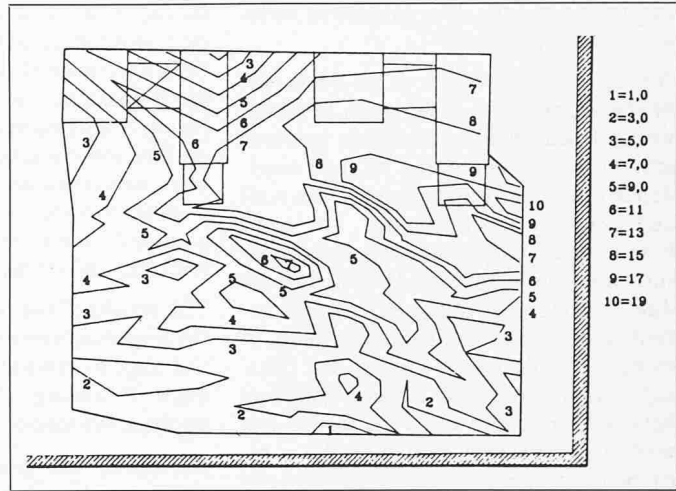

Fig. 10. Lines of equal vibratory level in a compressor room at 14 Hz

Table 3.

Absorber coupling point	ΔG_{11} [μN]
1	-11,92
15	-10,95
36	-10,30

the frame of this short paper, it is not possible to go into the mathematics underlying these techniques. I just refer to P. Vanhonacker's thesis [3] and to M. Mergeay articles [4] about respectively sensitivity analysis, system synthesis and modern curve fitting techniques.

The number of practical cases and industrial applications of these techniques are numerous, going from tennis rackets, to Dieselmotors, recordplayers, car bodies, etc., where a very various range of problems have been solved in the field of noise, vibration, fatigue, pneumatic failure, chatter, etc.

Floor vibration

Before concluding I want to mention briefly a very recent and rather unexpected application in noise and vibration problems, e. g. in view of the installation of a screw compressor.

In a factory a helicoidal compressor was to be installed in a room where two hea-

vy piston compressors were working at 420 rev/min. The acceleration was measured on the floor in 90 different points of which 70 were located in the region where the new compressor had to be installed.

The second harmonic at 14 Hz appeared to be dominant. Indeed, only the first one at 7 Hz was compensated in the compressor. Fig. 9 and 10 show the equi-acceleration lines for 7 Hz, resp. 14 Hz. After this experiment, the compressors were stopped and the natural frequencies of the floor plate was measured. Resonance frequencies were observed at 10, 40, 66, 122, 110, 388 Hz and the deformations obtained by modal analysis techniques. However, in order to minimize the cost it was decided to optimize passive isolation support for the helicoidal compressor. The result was convincing, no vibrations were transmitted.

Conclusions

I hope to have shown you that scientific work, which may appear to be merely theoretical, is relevant to industry. This was the case of modal analysis, where the combination of different techniques

of dynamic analysis, new experimental devices and mathematical tools as Fast Fourier Transforms, finite element, etc. provide a powerful aid for design.

References

[1] Van den Noortgate, L. (1982): "Moderne Technieken bij de trillingsbestrijding". MC 71 - CRIF - Brussel
 [2] Snoeys, R. Roesems, D. Vandeurzen, U. Vanhonacker, P. (1979): "Survey of Modal Analysis Applications". Annals of CIRP, Vol 28 part II
 [3] Vanhonacker, P. (1980): "The use of Modal Parameters of Mechanical Structures in Sensitivity Analysis - System Synthesis and System Identification". Doctoral thesis, K. U. Leuven, p. 1-14
 [4] Mergeay, M. Snoeys, R. (1982): "Multi degree of freedom Parameter Estimation methods for Modal Analysis". Annals of CIRP, Vol. 31 part I, p. 269-273
 Further bibliography in quoted references.

The authors address: Prof. J. Peters and R. Snoeys, Afdeling Mechanische Konstruktie en Productie, Katholieke Universiteit Leuven, Celestijnenlaan 300 B, B-3030 Leuven (Belgium); L. Van den Noortgate, Chief Engineer at the Metalworking Research Center (CRIF), Heverlee, Belgium.