

Tafeln

Objekttyp: **Appendix**

Zeitschrift: **Schweizerische Polytechnische Zeitschrift**

Band (Jahr): **3 (1858)**

Heft 5

PDF erstellt am: **10.08.2024**

Nutzungsbedingungen

Die ETH-Bibliothek ist Anbieterin der digitalisierten Zeitschriften. Sie besitzt keine Urheberrechte an den Inhalten der Zeitschriften. Die Rechte liegen in der Regel bei den Herausgebern. Die auf der Plattform e-periodica veröffentlichten Dokumente stehen für nicht-kommerzielle Zwecke in Lehre und Forschung sowie für die private Nutzung frei zur Verfügung. Einzelne Dateien oder Ausdrucke aus diesem Angebot können zusammen mit diesen Nutzungsbedingungen und den korrekten Herkunftsbezeichnungen weitergegeben werden. Das Veröffentlichen von Bildern in Print- und Online-Publikationen ist nur mit vorheriger Genehmigung der Rechteinhaber erlaubt. Die systematische Speicherung von Teilen des elektronischen Angebots auf anderen Servern bedarf ebenfalls des schriftlichen Einverständnisses der Rechteinhaber.

Haftungsausschluss

Alle Angaben erfolgen ohne Gewähr für Vollständigkeit oder Richtigkeit. Es wird keine Haftung übernommen für Schäden durch die Verwendung von Informationen aus diesem Online-Angebot oder durch das Fehlen von Informationen. Dies gilt auch für Inhalte Dritter, die über dieses Angebot zugänglich sind.

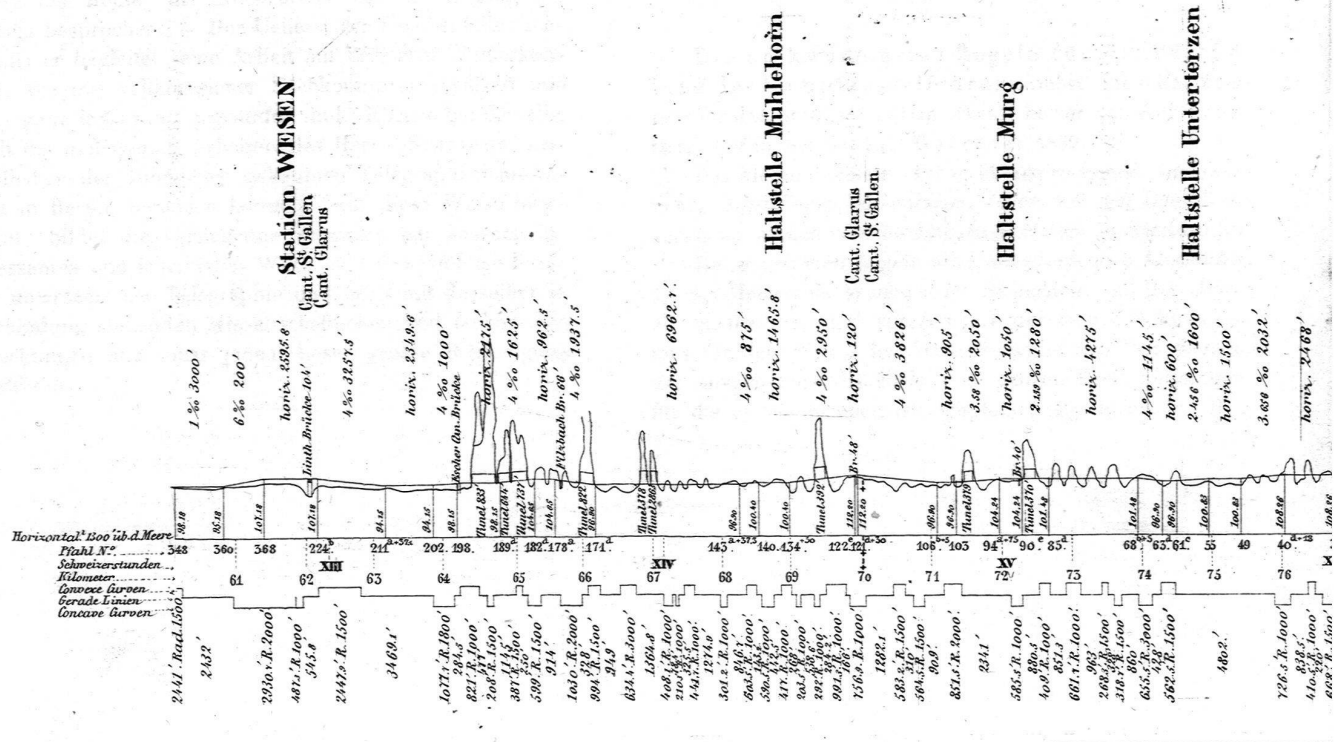
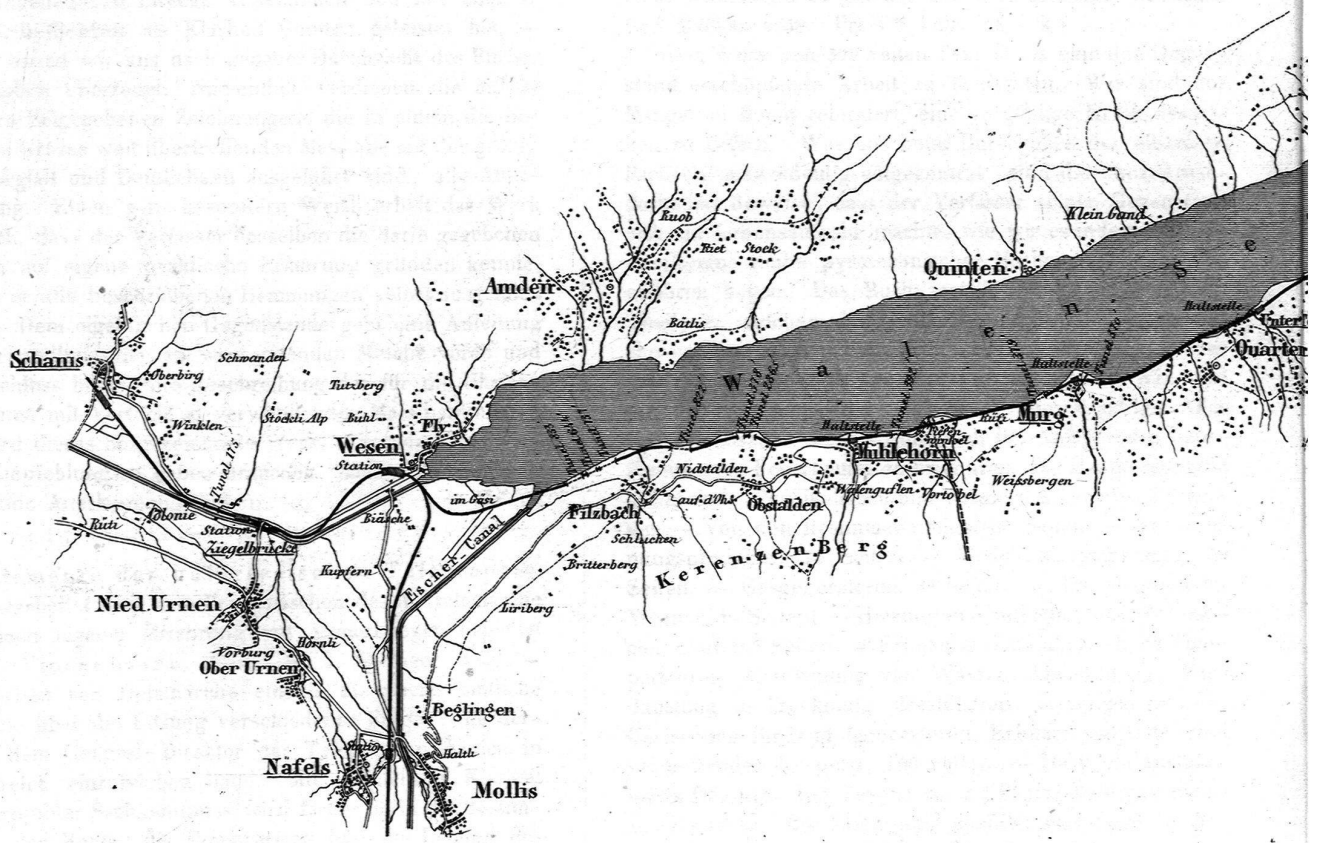

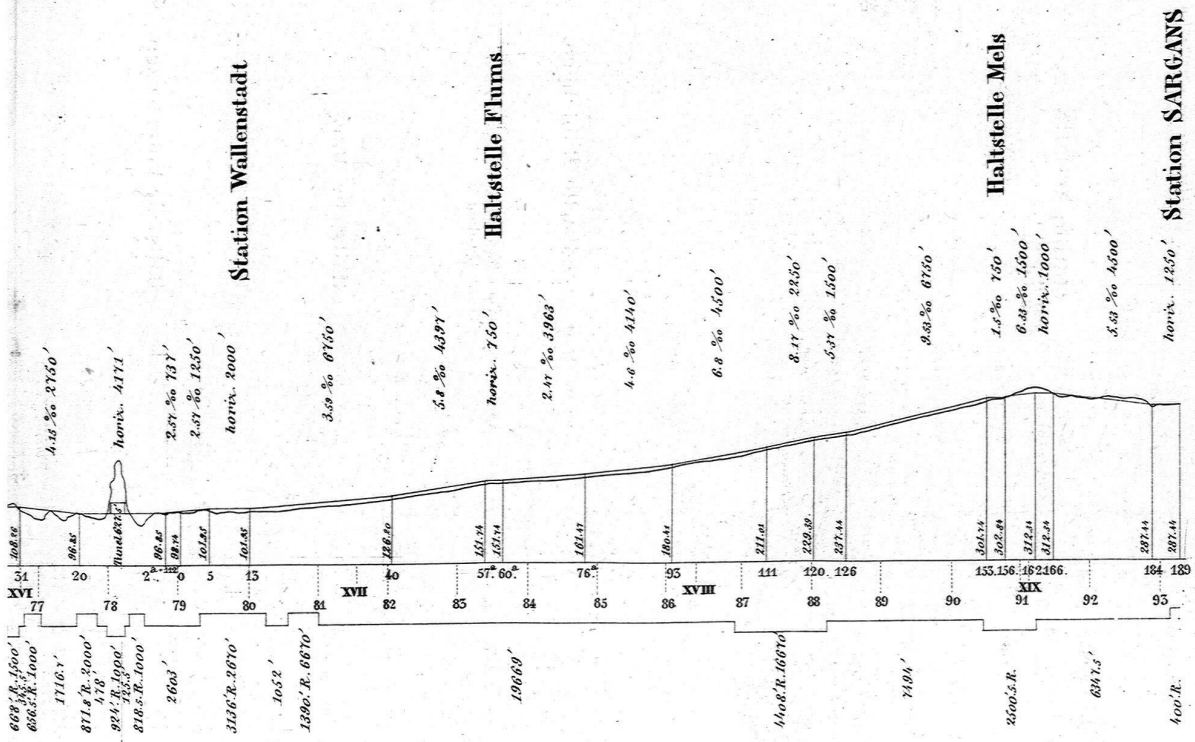
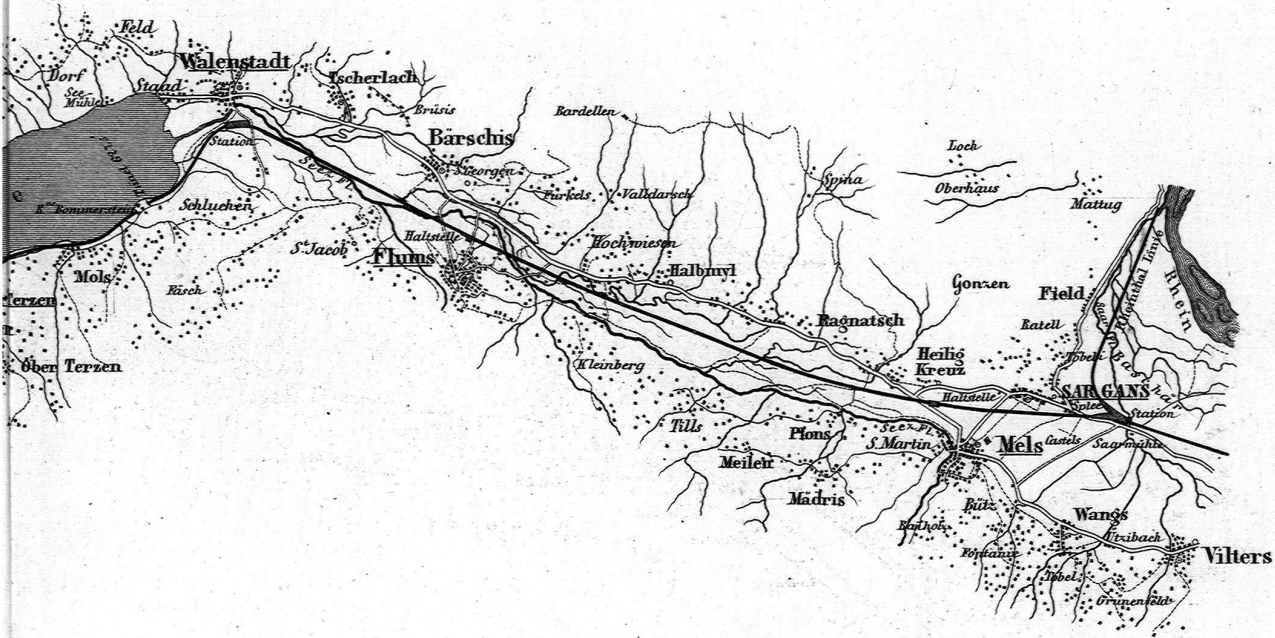

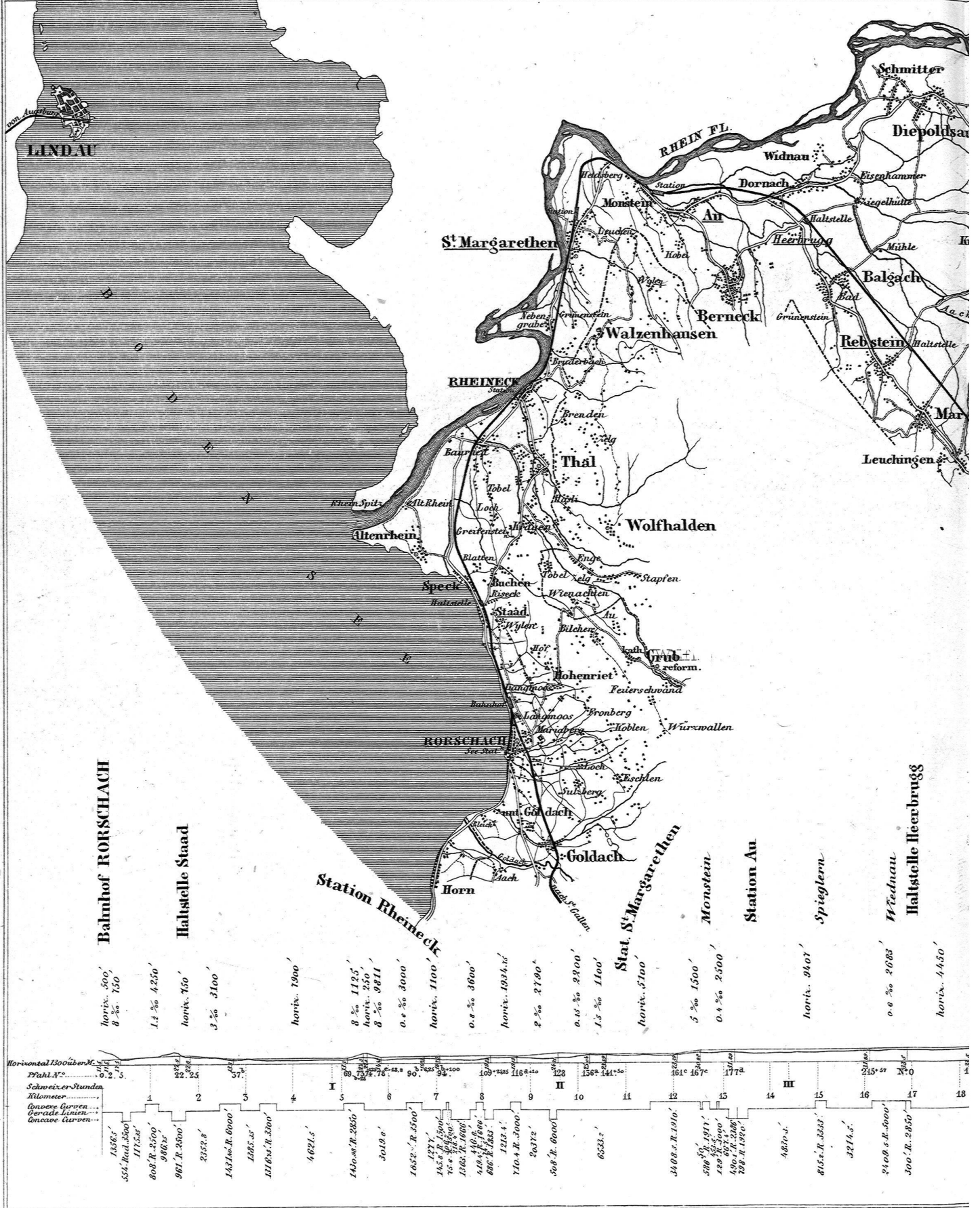

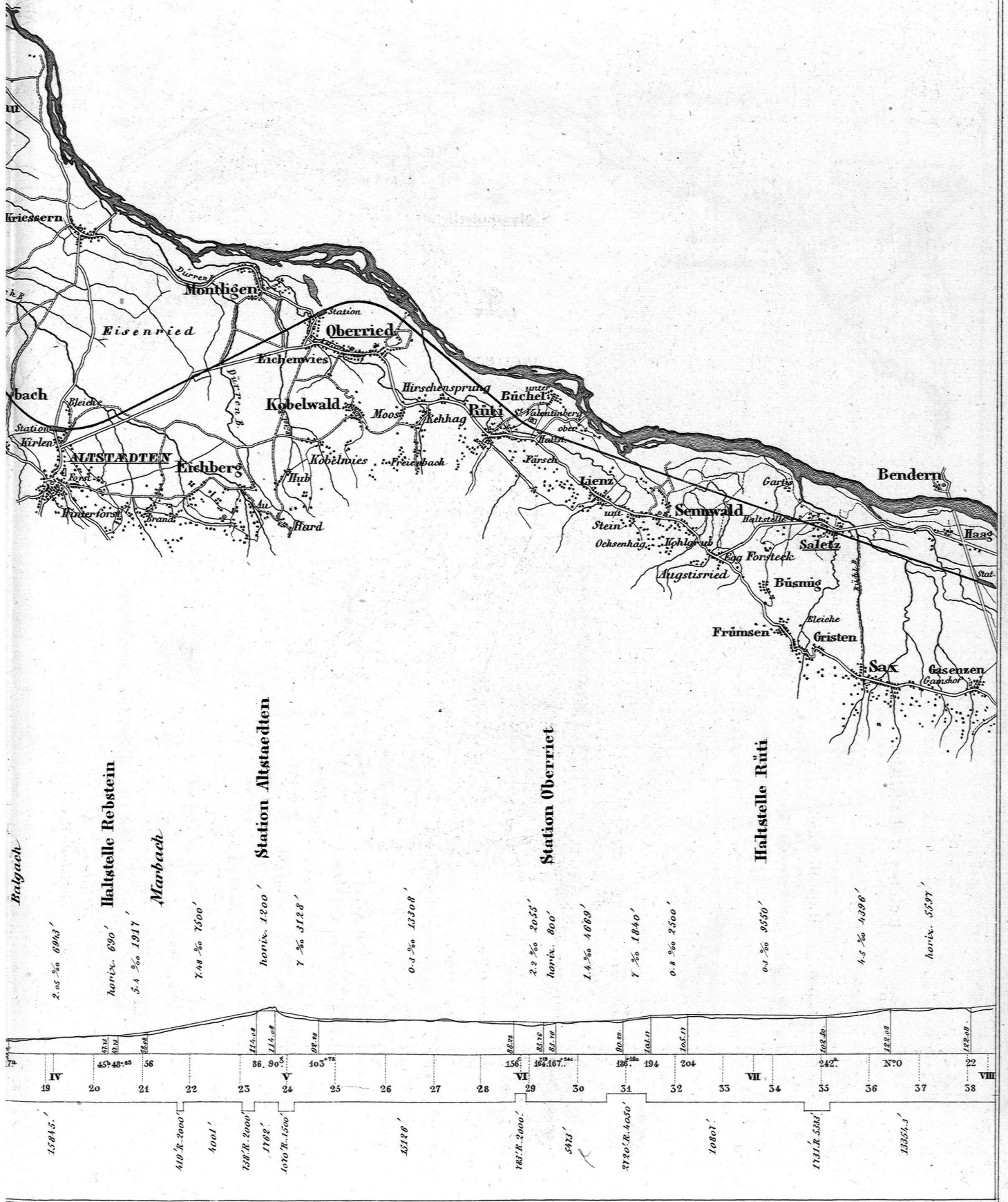

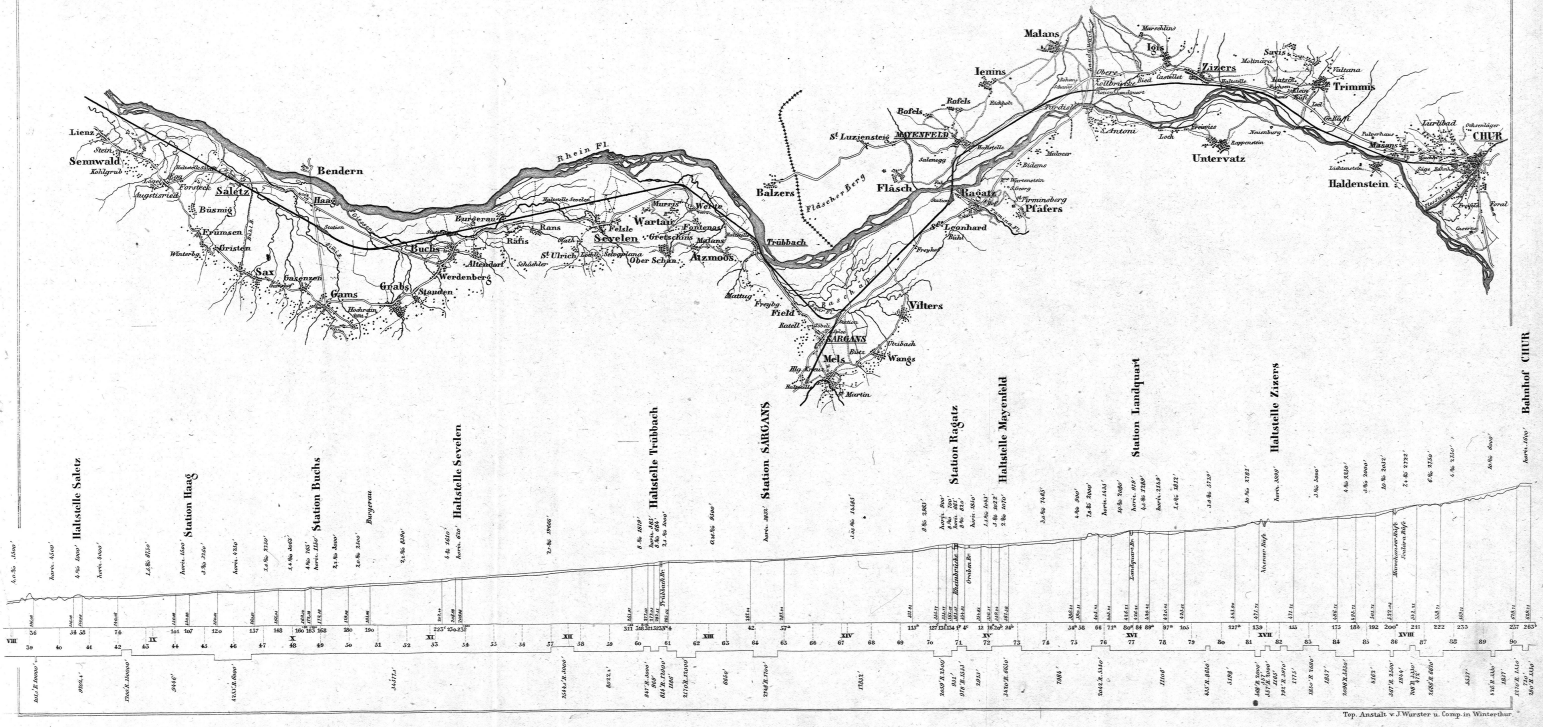

Top-Ansicht v. J. Wurster in Comp. in Winterthur

Fig. 1.

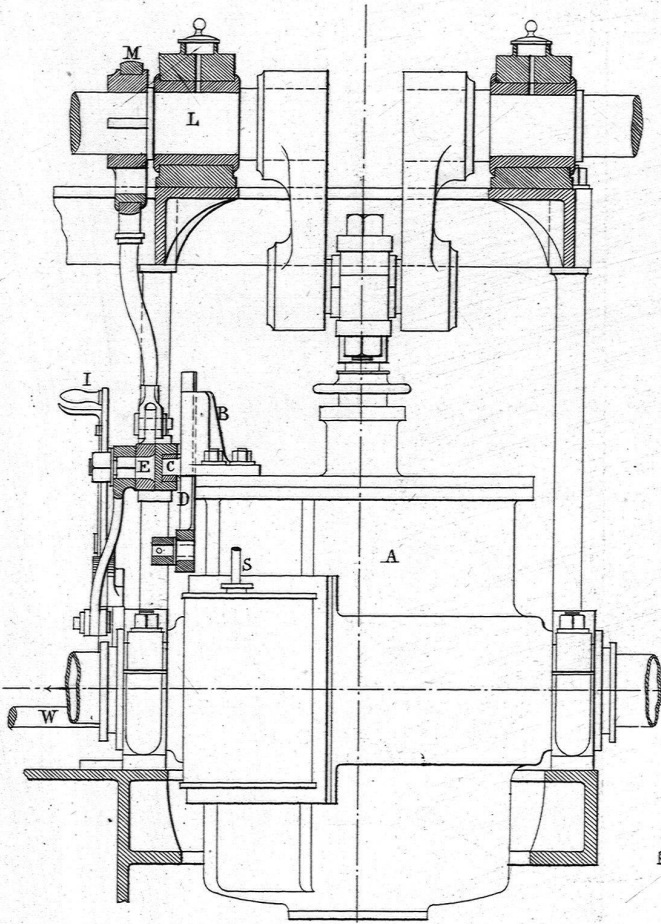

Fig. 2.

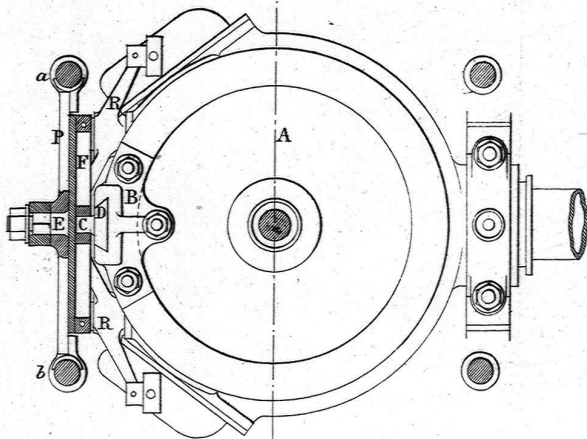
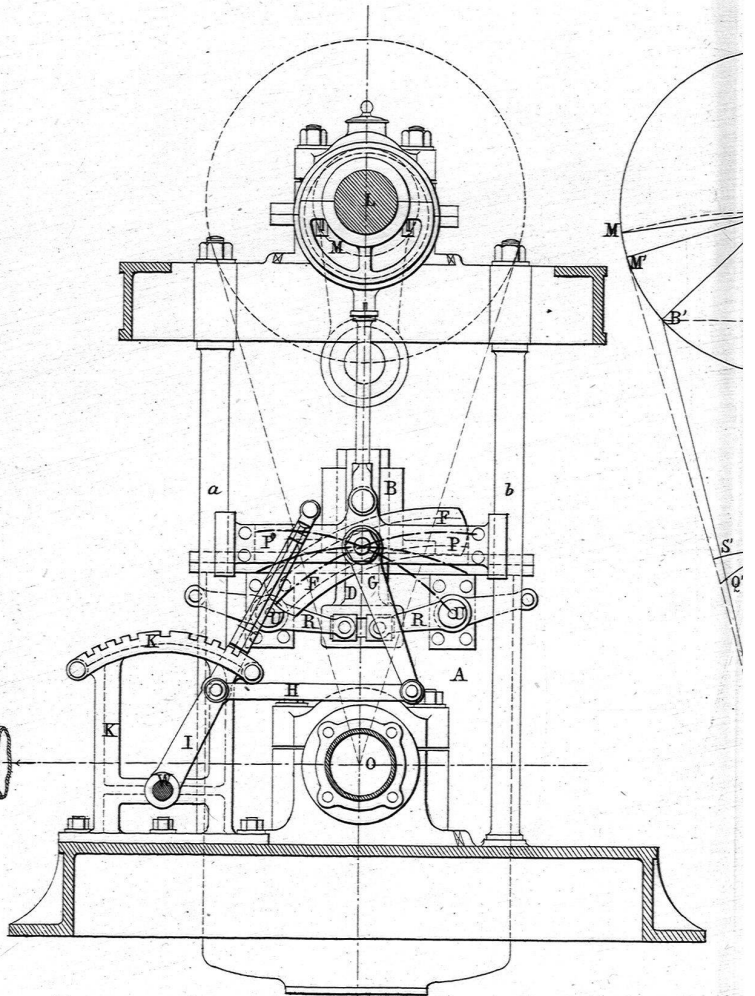

Fig. 3.

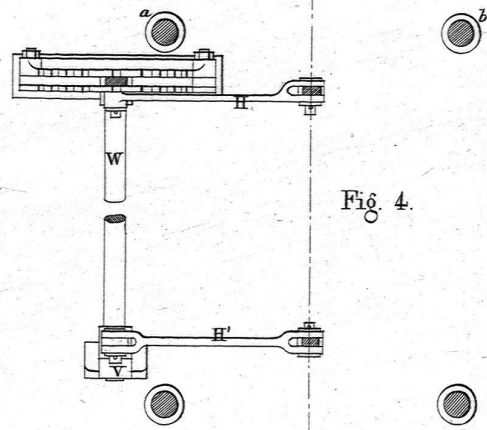

Fig. 4.

ende Schiffsmaschinen.
gler in Zürich.

Fig. 6.

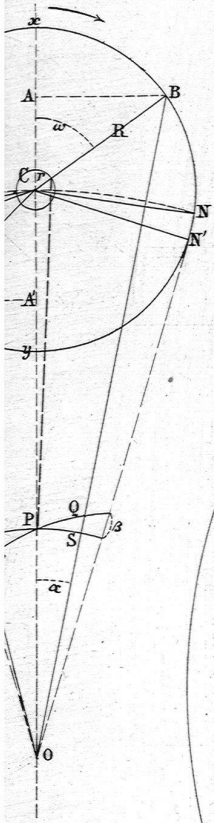
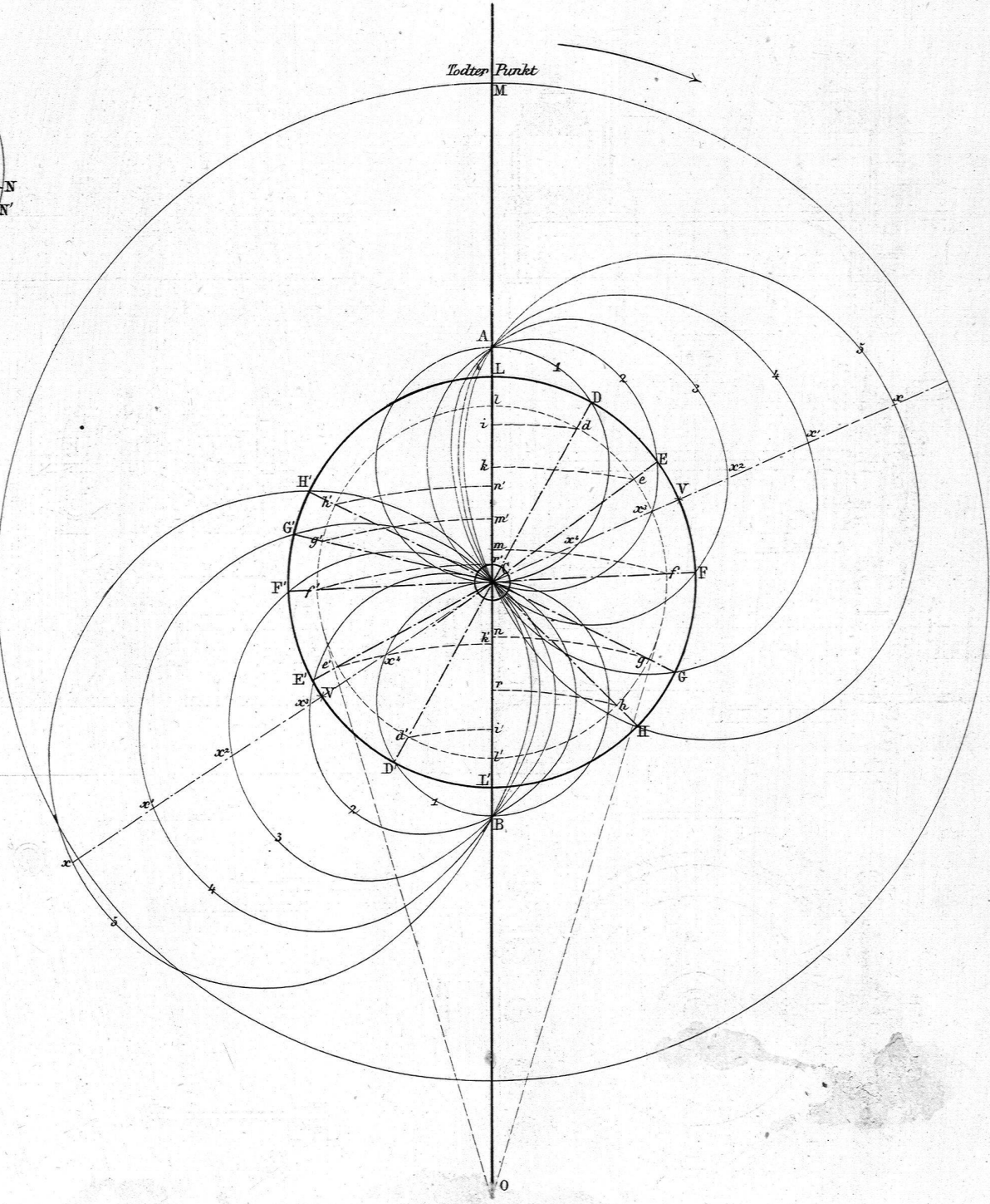
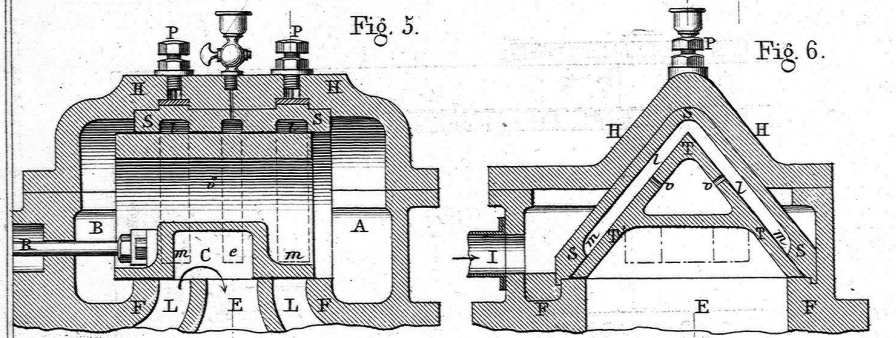
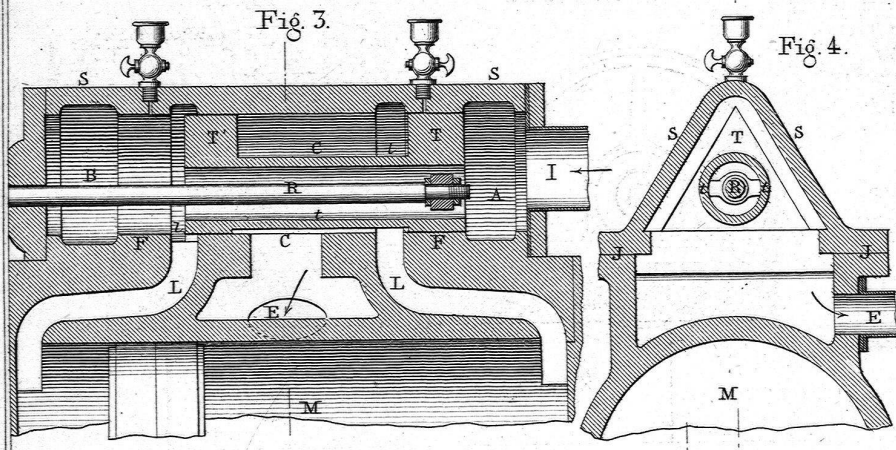
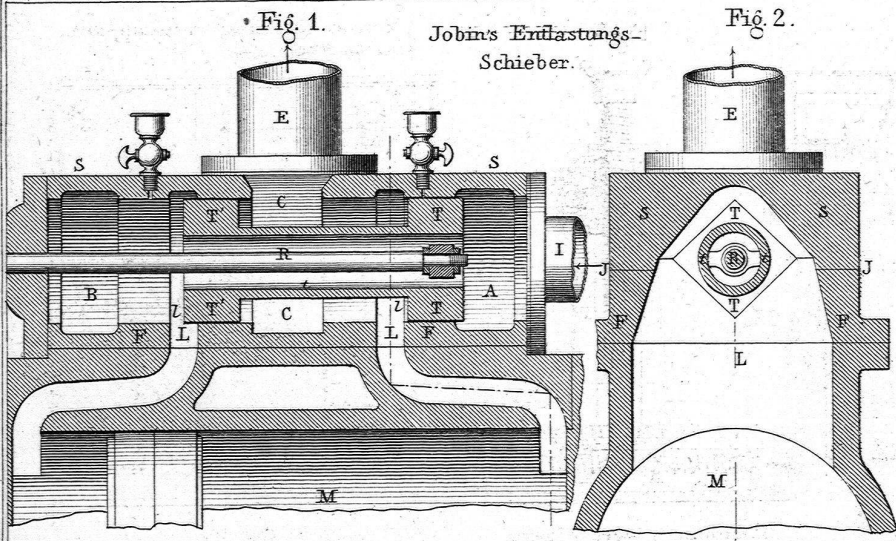

Fig. 5.



Jobin's Entlastungs-Schieber.



Maßstab $\frac{3}{10}$. 1 Meter

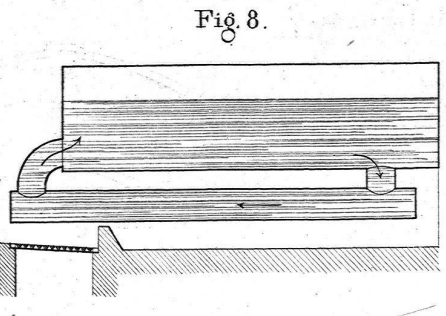
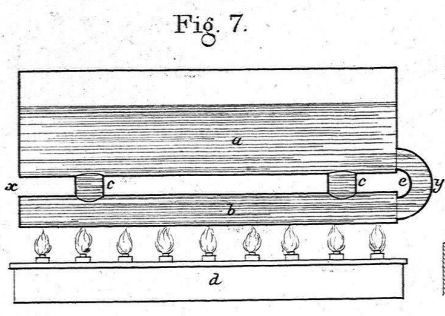

Grangoir's verb. Sc
Maßstab $\frac{3}{2}$

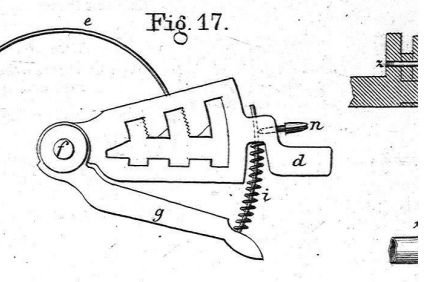
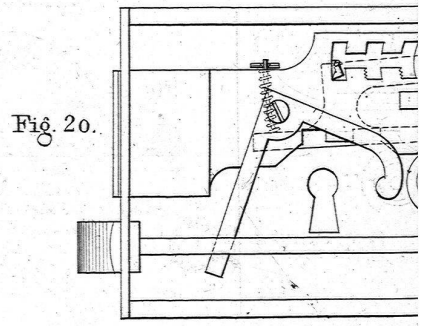
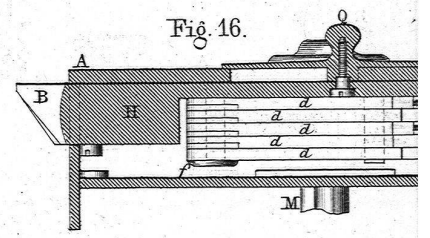
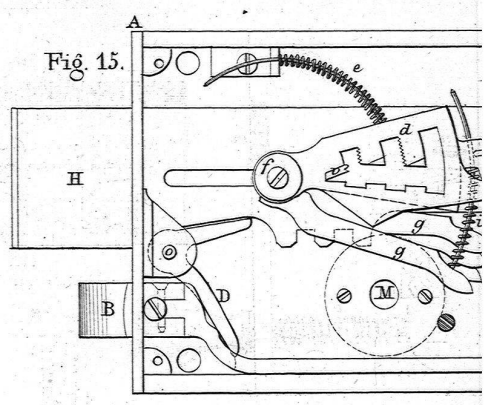
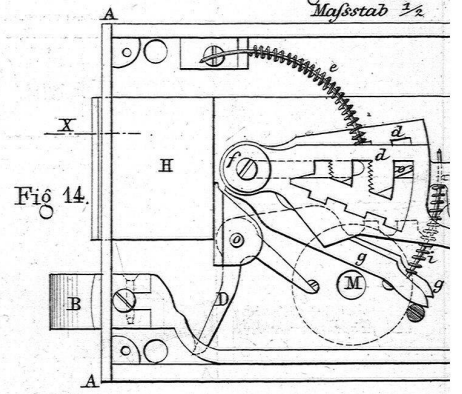

schlösser

Fig. 34.

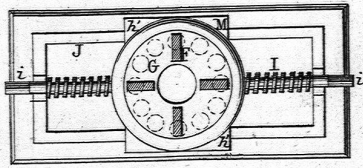
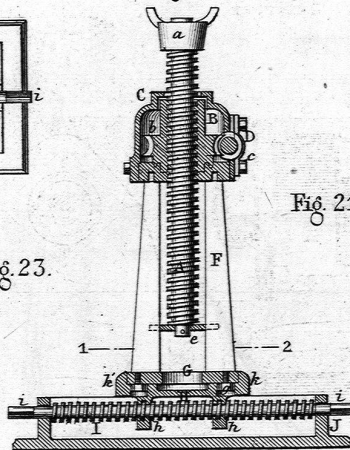

Fig. 30.



Münster's Wächter-controlapparat.
nach der Wächterstube

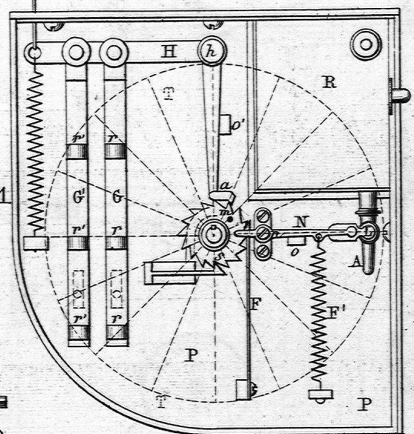

Fig. 21

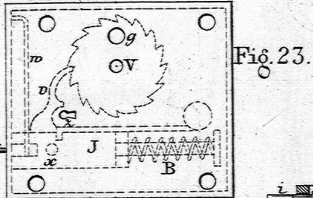
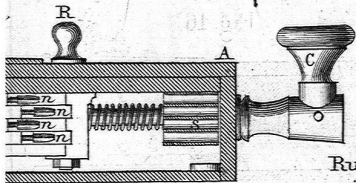
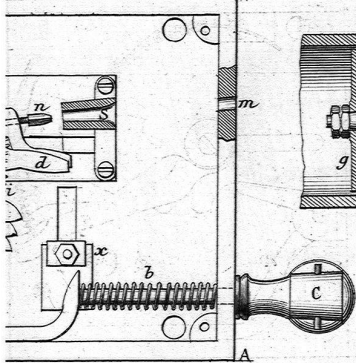
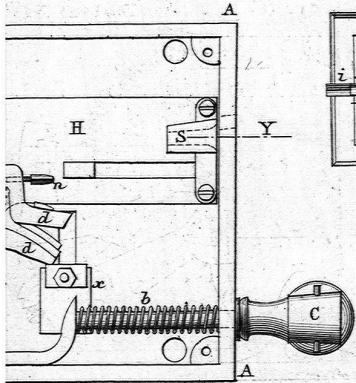

Fig. 23.



Chaumont's Kolben

Fig. 28.

Fig. 29.

Ruppert's Gitterbrücken
Über den Pfeilern.

Gewicht des laufenden Fußes = 20812 Pfd.
Querschnitt = 0.004728 □ 7^m

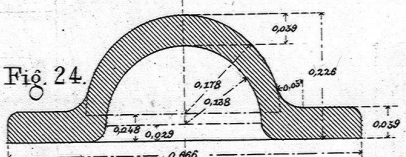

Fig. 24.

Unächst der Pfeiler
Gewicht des laufenden Fußes = 16412 Pfd.
Querschnitt = 0.003727 □ 7^m

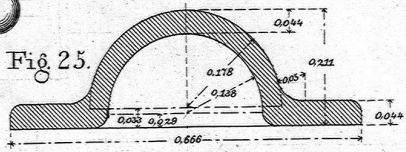

Fig. 25.

Mitte der Öffnung
Gewicht des laufenden Fußes = 12628 Pfd.
Querschnitt = 0.002888 □ 7^m

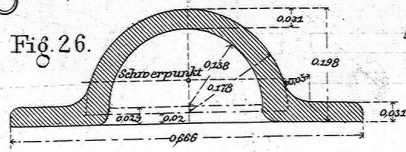

Fig. 26.

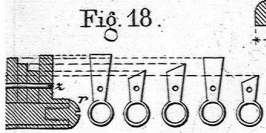

Fig. 19.

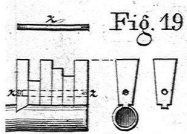

Fig. 18.

Lemonnier's verb. Winden.

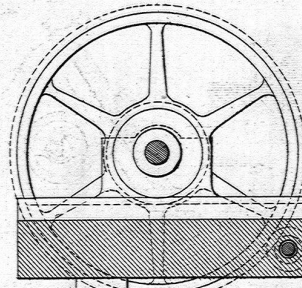

Fig. 22.

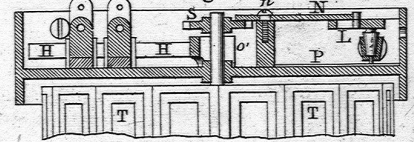

Fig. 9.

Kilburn's Holzbiegmaschine.

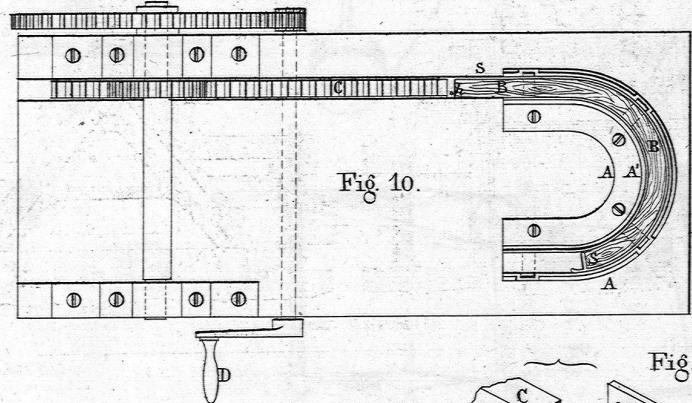

Fig. 10.

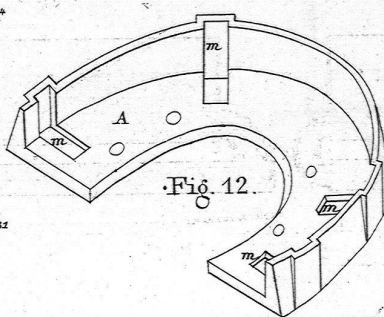

Fig. 12.

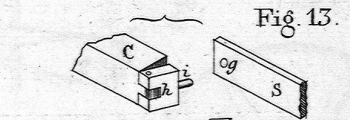

Fig. 13.

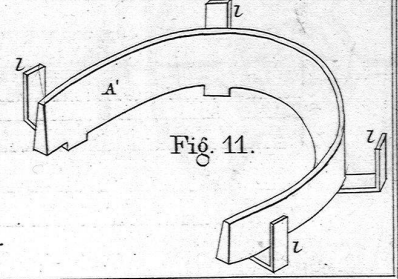

Fig. 11.

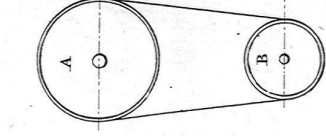

Fig. 1.

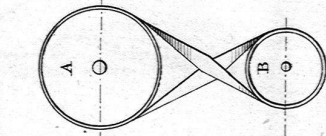

Fig. 3.

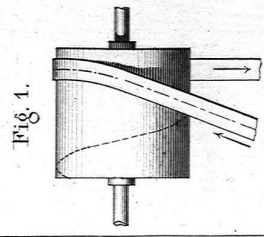
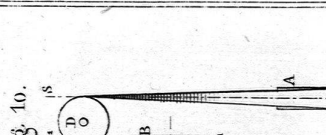
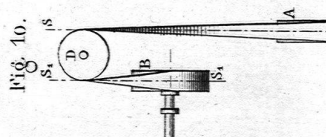
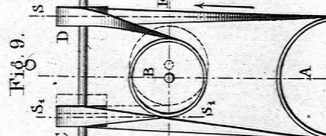
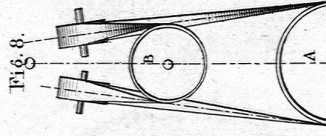
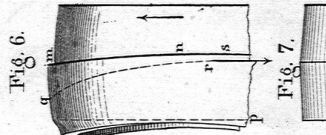
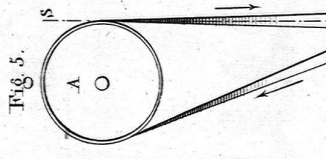
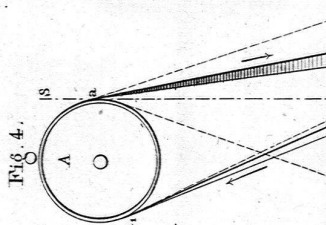

Fig. 12.

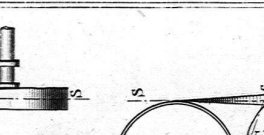
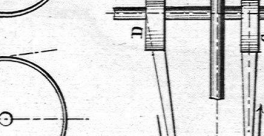
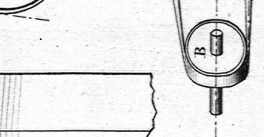
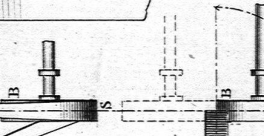
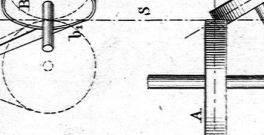
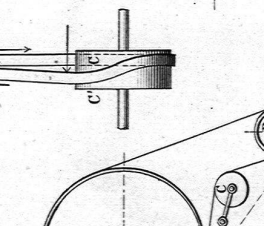
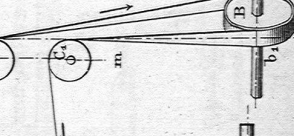
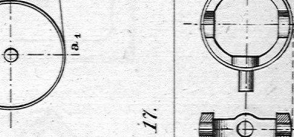
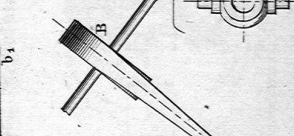
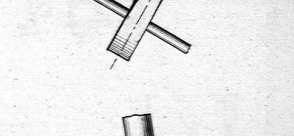
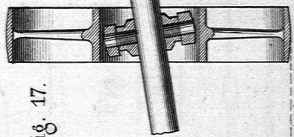
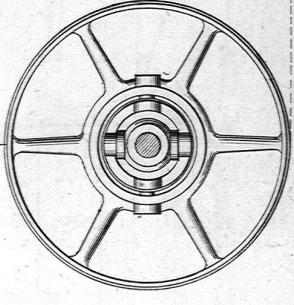
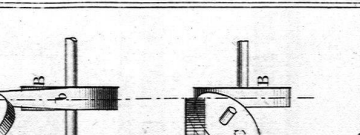
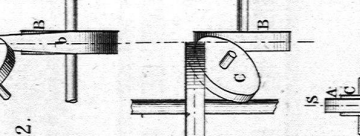
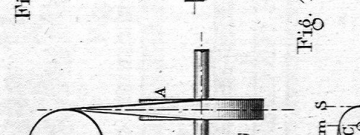
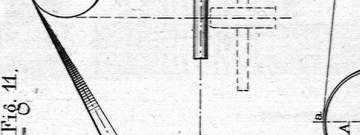
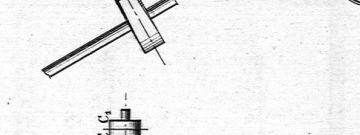
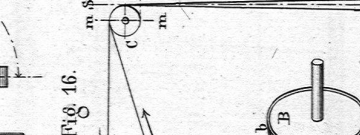
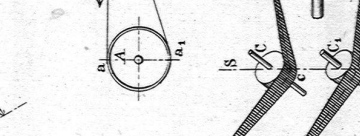
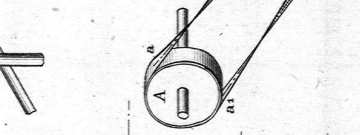
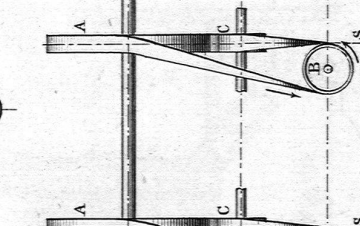
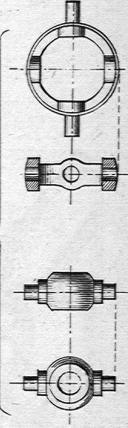
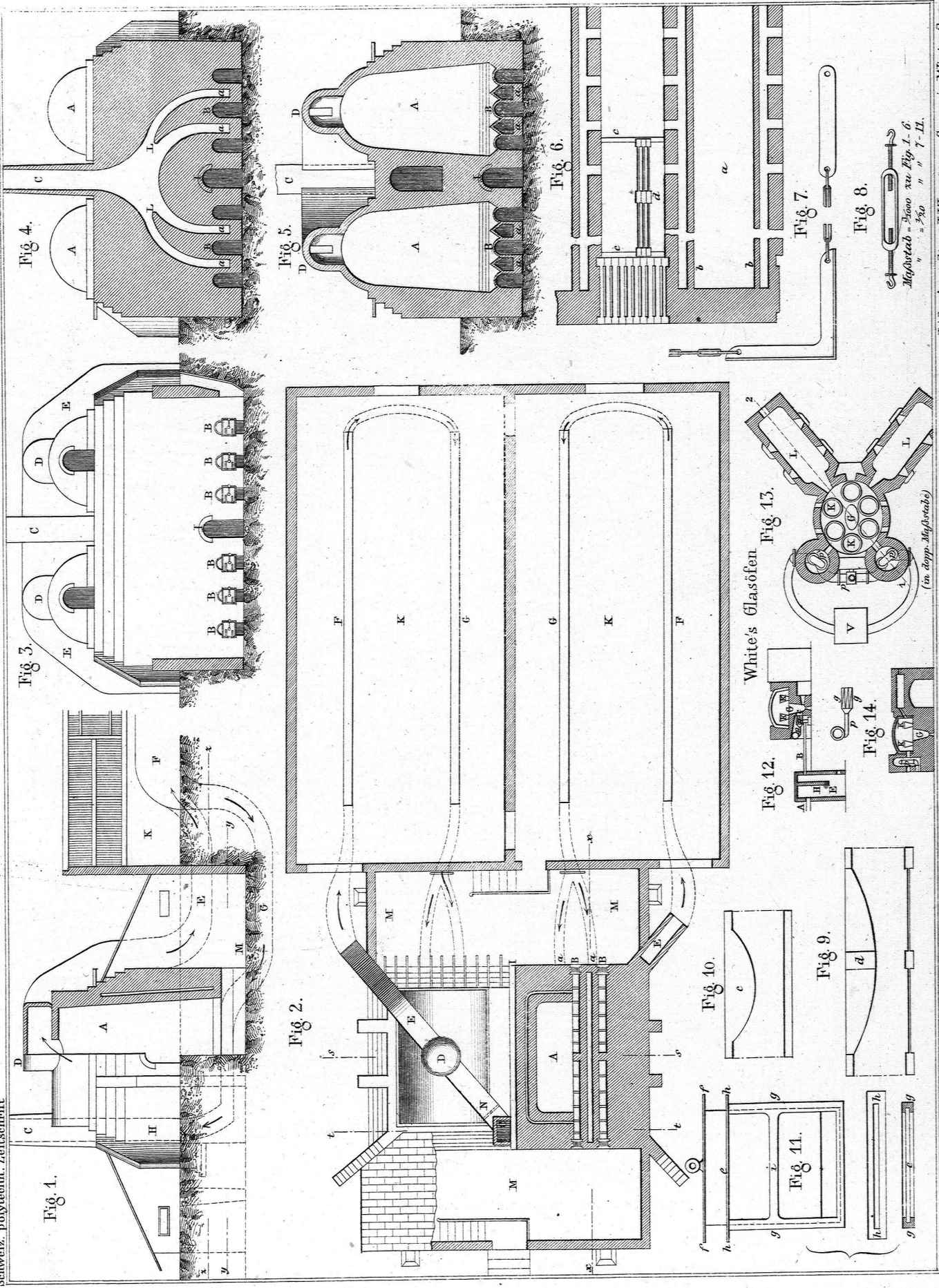

Fig. 13.



Details zu Fig. 17.





Messstab = 2000 zu Fig. 1-6
 " " 250 " " 7-11.
 " " 500 " " 12-14.