

The Lima RAe TEE (4-car set)

Autor(en): **Jesson, John**

Objektyp: **Article**

Zeitschrift: **Swiss express : the Swiss Railways Society journal**

Band (Jahr): **1 (1986-1987)**

Heft 9

PDF erstellt am: **15.08.2024**

Persistenter Link: <https://doi.org/10.5169/seals-853700>

Nutzungsbedingungen

Die ETH-Bibliothek ist Anbieterin der digitalisierten Zeitschriften. Sie besitzt keine Urheberrechte an den Inhalten der Zeitschriften. Die Rechte liegen in der Regel bei den Herausgebern. Die auf der Plattform e-periodica veröffentlichten Dokumente stehen für nicht-kommerzielle Zwecke in Lehre und Forschung sowie für die private Nutzung frei zur Verfügung. Einzelne Dateien oder Ausdrucke aus diesem Angebot können zusammen mit diesen Nutzungsbedingungen und den korrekten Herkunftsbezeichnungen weitergegeben werden. Das Veröffentlichen von Bildern in Print- und Online-Publikationen ist nur mit vorheriger Genehmigung der Rechteinhaber erlaubt. Die systematische Speicherung von Teilen des elektronischen Angebots auf anderen Servern bedarf ebenfalls des schriftlichen Einverständnisses der Rechteinhaber.

Haftungsausschluss

Alle Angaben erfolgen ohne Gewähr für Vollständigkeit oder Richtigkeit. Es wird keine Haftung übernommen für Schäden durch die Verwendung von Informationen aus diesem Online-Angebot oder durch das Fehlen von Informationen. Dies gilt auch für Inhalte Dritter, die über dieses Angebot zugänglich sind.

THE LIMA RAe TEE (4 - CAR SET) | by John Jesson

Cat. No. 9812. Additional coach Cat. No. 1005. Restaurant car Cat. No. 1006

Available in Europe since the summer of 1986, the long-awaited Lima RAe set finally arrived at Victors in December, together with the two additional coaches. It is a fine model, ingenious in its design and accurate in its dimensions, but with one or two defects which Lima should attend to if they are to join the Roco's, Liliput's, etc. of this world.

It is difficult to judge accurately the length of the individual vehicles. The drawing usually used by publications gives only the length over body, but part of this length is hidden by the inter-coach air-smoothing, I estimate this hidden part to be about 250mm at each inner end, giving the lengths I have quoted in the table.



RAe TEE unit no. 1054 races through Lugano Paradiso with the northbound "Gottardo" May 1981. Photo John Stein.

The model is powered by an enclosed 3-pole motor mounted in the centre of the power car. A flywheel is fitted at each end of the motor, and the drive is transmitted to the outer axles of both bogies through cardan shafts and bogie-mounted gear boxes. Rubber traction tyres are fitted to one pair of wheels.

Current collection from one rail is through the extreme end bogies of the unit, and from the other rail through the wheels of the powered bogies. From the end vehicles, the current is transmitted to the power car through metal couplings, which are also the means of coupling the individual coaches together. The pantographs are non operating, and are not electrically connected to the motor.

Between the coaches, the gap is filled, very effectively, by rigid plastic representations of the prototypes' air-smoothing. Just how reliable these are on very tight radius curves I cannot say, but they coped well with curves down to 2 ft. radius, including a reverse curve, although their appearance was, naturally, unprototypical.

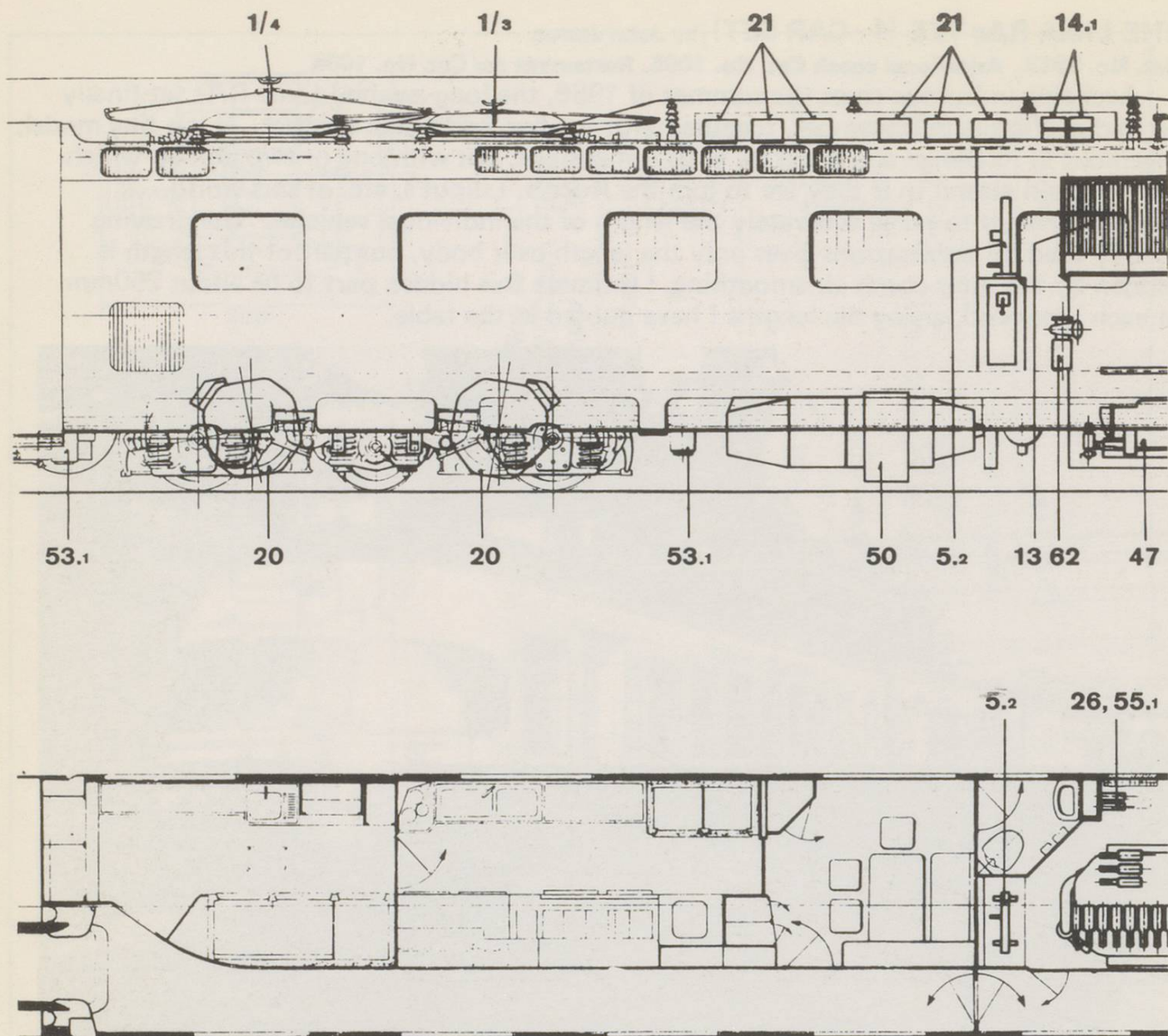

The model comes with a cutout above each bogie. Lima supply clip-in skirts to fill these gaps, but they say they are only for use with display models. ! The reason for this is that, once installed, the swing of the bogies is severely reduced or, in some cases, rendered impossible. Indeed, in one place it was impossible to even fit the skirts as the bogie was in the way.

As I wanted both the skirts and an operable model, I looked for ways to achieve both aims. The solution called for cementing the skirts in place and once the cement was thoroughly set, removing those of the fixing lugs which fouled the bogies. To give freedom of movement to the bogies under the entrance doors I found it necessary to shave off part of the step supports and also to cut away part of the bogie sideframes. This last was not a particularly easy task, but the end result is a unit which will negotiate 3 ft. radius curves, with the modifications quite invisible.

I was not too impressed by the standard of the paintwork, and got the impression that Lima had painted the models in a hurry and boxed them before completely dry. Nevertheless, my model is acceptable at normal viewing distances, and it must be said that the printed inscriptions are superb. My set of skirts are a slightly different shade of red to the main bodysides, and I have played around with a number of different paints to try to get the same shade, so far without complete success. The closest I have found is Roco 7001-Purpurrot.

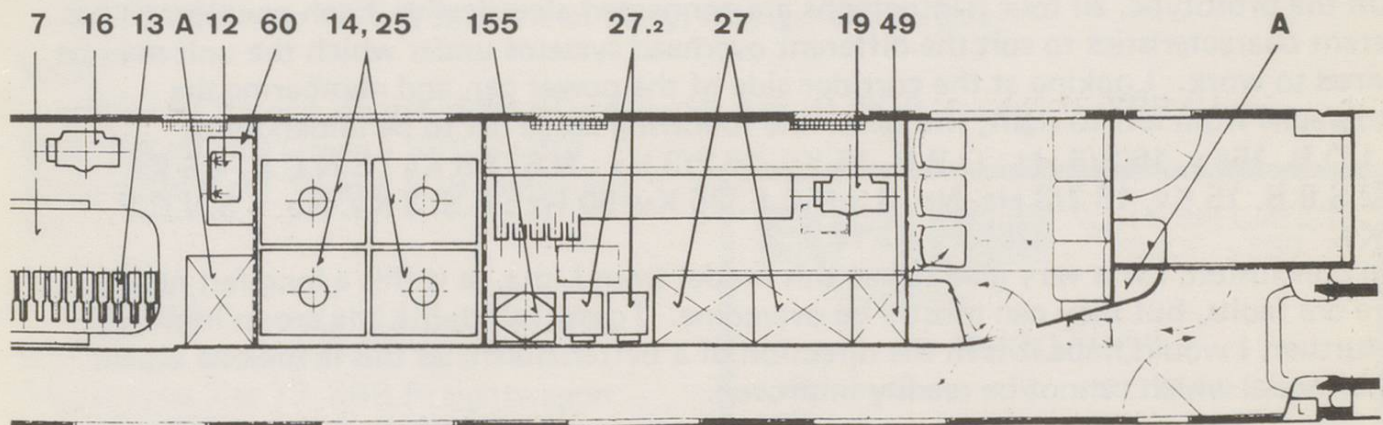
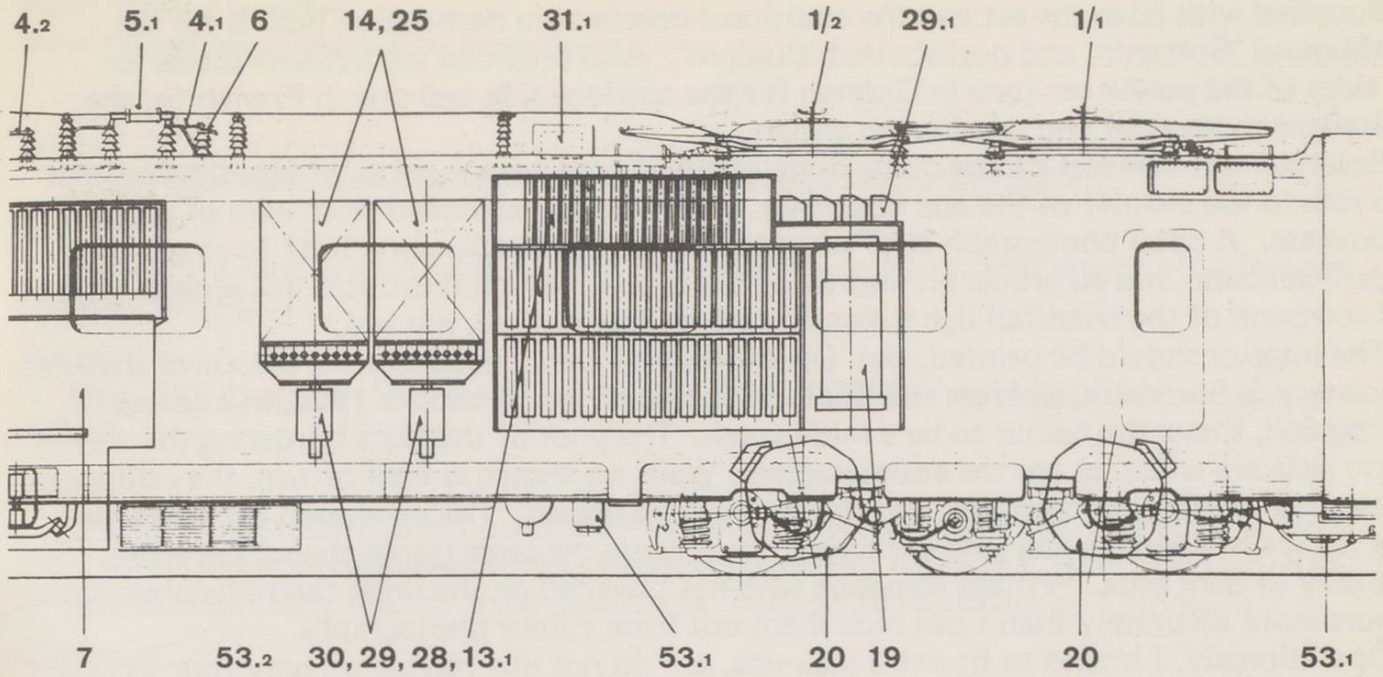

Arrangement of the electrical equipment in the motor carriage.

- | | | | |
|-------|--------------------------------------------------------------|------|------------------------------------------|
| 1/1-4 | Pantograph | 30 | Field-weakening contactor |
| 4.1 | Earthing switch | 47 | Three-phase compressor |
| 4.2 | Change-over switch earth to d.c. | 49 | Silicon rectifier for auxiliary services |
| 5.1 | Main circuit breaker for 25 kV a. c. | 50 | Converter unit for auxiliary drives |
| 5.2 | Circuit breaker for 3 kV d.c. | 53.1 | Blower motor for traction motor |
| 6 | High tension bushing 25 kV for the system selector equipment | 55.1 | Starting contactor |
| 7 | Main transformer | 60.1 | Three-phase transformer |
| 12 | Voltage transformer | 155 | Servo-controller |
| 13 | Tap-changing contactor on the transformer | A | Equipment box |
| 13.1 | Tap-changing contactor for the starting resistor | | |
| 14 | Starting and braking resistor | | |
| 14.1 | Change-over resistor | | |
| 16 | System change-over switch | | |
| 19 | Reversing and brake change-over switch | | |
| 20 | Traction motor | | |
| 21 | Pulsating d.c. shunt | | |
| 26 | Brake contactor | | |
| 27 | Silicon rectifier for traction motors | | |
| 27.2 | Electro-pneumatic isolating circuit breaker for Item 27 | | |
| 28 | Electro-pneumatic contactor for rheostatic brake | | |
| 29 | Grouping and isolating contactor | | |

Drawing supplied by
Oerlikon Engineering Company.

Supplied with both the set and the additional coaches are destination boards for the southbound 'Gottardo' and northbound 'Cisalpin'. Also provided are builders plates for the sides of the power car (one in German for the corridor side and one in French for the equipment room side) and windscreen wipers.

Several improvements can be made quite easily. There are a number of pipes, cables and grab rails in the vicinity of the end couplings, which can be fashioned from wire of various thicknesses. A good photograph is an advantage here, and the January 1987 issue of 'Die Modelleisenbahn' has an article on improving the model which illustrates this aspect. The oval surround of the head/tail lights should have a silver surface, not red.

The interior should be painted, but 'Die Modelleisenbahn' describes the colour of the upholstery as bordeaux, whereas the 'Bulletin Oerlikon' for December 1962, in a colour photograph, shows the colour to be a mid-brown. The ends of the seats bordering the centre aisle are white, as are the antimacassars. Walls are shown as light brown, the ceiling seems to be mushroom-coloured, and the carpet dark brown. The restaurant car seems to have red walls, white ceiling and dark grey floor, while the seats (loose chairs) are either dark grey or dark blue. Perhaps someone who has travelled on the units can remember the colours more accurately than I can pick them out from colour photographs.

Operationally, I intend to fit extra pick-ups, as I do not like relying on only four wheels on each side when there are so many more on the unit. Pantographs will need to be replaced, and by the time this appears in print, Sommerfeld or someone else will probably have promised a set of working pantographs of the off-set pattern unique to this unit.

On the prototype, all four pantographs are connected electrically. Each pantograph has different characteristics to suit the different overhead systems under which the unit may be required to work. Looking at the corridor side of the power car, and numbering the pantographs from left to right, will allow the following usage list to be understood.

No. 1 D.B. 15Kv, 16 2/3 Hz : O.B.B. 15 Kv, 16 2/3 Hz : N.S. 1,5 Kv : S.N.C.B. 1,5 Kv.
No. 2 S.B.B. 15 Kv, 16 2/3 Hz. No. 3 S.N.C.F. 25 Kv, 50 Hz : F.S. 3 Kv. No. 4 S.N.C.F. 1,5 Kv.

In conclusion, I was very glad to see this model from Lima, as it fills a long-felt need. There are faults, but they can mostly be overcome. To my mind, if Lima are to improve still further, I would hope it is in the direction of a better finish, as this is the one aspect of this model which cannot be readily improved.

| | Length over bodyside | | | Height | | | Width | | |
|---------------|----------------------|-------|-------|--------|------|-------|-------|------|-------|
| | 1:1 | 1:87 | model | 1:1 | 1:87 | model | 1:1 | 1:87 | model |
| End coach | 24950 | 286,8 | 286,9 | 4000 | 46,0 | 45,8 | 2840 | 32,6 | 32,8 |
| Trailer coach | 23400 | 269,0 | 269,8 | 4000 | 46,0 | 45,8 | 2840 | 32,6 | 32,7 |
| Power car | 23700 | 272,4 | 273,5 | 4000 | 46,0 | 46,0 | 2840 | 32,6 | 32,8 |
| Restaurant | 23400 | 269,0 | 270,0 | 4000 | 46,0 | 45,7 | 2840 | 32,6 | 32,5 |
| Add. trailer | 23400 | 269,0 | 269,8 | 4000 | 46,0 | 45,5 | 2840 | 32,6 | 32,6 |
| End coach | 24950 | 286,8 | 286,9 | 4000 | 46,0 | 45,6 | 2840 | 32,6 | 32,8 |

| | Bogie centres | | | Bogie wheelbase | | |
|---------------|---------------|-------|-------|-----------------|------|-------|
| | 1:1 | 1:87 | model | 1:1 | 1:87 | model |
| End coach | 18300 | 210,3 | 210,3 | 2700 | 31,0 | 31,0 |
| Trailer coach | 18300 | 210,3 | 210,3 | 2700 | 31,0 | 31,0 |
| Power car | 17000 | 195,4 | 195,9 | 3800 | 43,7 | 43,5 |
| Restaurant | 18300 | 210,3 | 210,3 | 2700 | 31,0 | 31,0 |
| Add. trailer | 18300 | 210,3 | 210,3 | 2700 | 31,0 | 31,0 |
| End coach | 18300 | 210,3 | 210,3 | 2700 | 31,0 | 31,0 |

| | 1:1 | 1:87 | model |
|------------------------------------------|--------|--------|-------------|
| Length of 6-car set (excluding couplers) | 148925 | 1711,8 | 1709 - 1712 |